



Chipsmall Limited consists of a professional team with an average of over 10 year of expertise in the distribution of electronic components. Based in Hongkong, we have already established firm and mutual-benefit business relationships with customers from,Europe,America and south Asia,supplying obsolete and hard-to-find components to meet their specific needs.

With the principle of “Quality Parts,Customers Priority,Honest Operation,and Considerate Service”,our business mainly focus on the distribution of electronic components. Line cards we deal with include Microchip,ALPS,ROHM,Xilinx,Pulse,ON,Everlight and Freescale. Main products comprise IC,Modules,Potentiometer,IC Socket,Relay,Connector.Our parts cover such applications as commercial,industrial, and automotives areas.

We are looking forward to setting up business relationship with you and hope to provide you with the best service and solution. Let us make a better world for our industry!



## Contact us

Tel: +86-755-8981 8866 Fax: +86-755-8427 6832

Email & Skype: info@chipsmall.com Web: www.chipsmall.com

Address: A1208, Overseas Decoration Building, #122 Zhenhua RD., Futian, Shenzhen, China



# Type W2GF-02 Touch Switch with FG Terminal



## ■ Features

- Built-in type ideal for touch detection in gaming machines.
- Touch switch appropriate for each application becomes available only by attaching product electrode to conductive member with screw.
- Use of FG terminal allows easy prevention of static electricity intruding from human body to electrode.
- Compatible with 5 to 15 DCV. Open collector output.

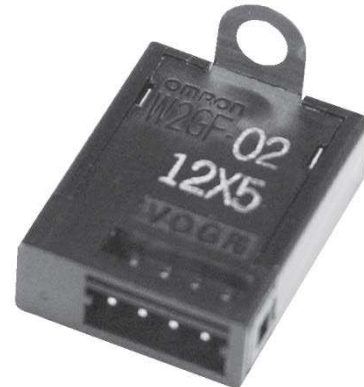

## ■ Type code standard

Type W2GF-02 (1) Represents a touch switch  
 (1) (2) (2) Represents a series name

## ■ Rating/performance

Item	Rating/performance
Detection capacitance (*1)	25 ± 5 pF
Electrical rating	5 DCV (-10%) to 15 DCV (+10%)
Output	Open collector (Maximum output current: 50 mA)
Way of operation	When capacitance detected (Presence of human body contact): Output transistor ON When capacitance not detected (Absence of human body contact): Output transistor OFF
Current consumption	10 mA or less
Effect of voltage	Within the range of ±10% of the rated power voltage, the rate of change in the detection capacitance must be within ±10% relative to the detection capacitance provided at the time of the rated power voltage.
Effect of temperature	Under operation within the specified ambient temperature range, the rate of change in the detection capacitance must be within ±10% relative to the detection capacitance provided at 23 deg C.
Ambient temperature	When in use: -10 to 60 deg C (must be free from freezing or condensation) When stored: -20 to 70 deg C (must be free from freezing or condensation.)
Ambient humidity	25 to 85% RH

\*1. Detection capacitance refers to the capacitance value that triggers detection when the path between the electrode and GND terminal of the touch switch circuit is electrically charged.

## ■ Output circuit diagram

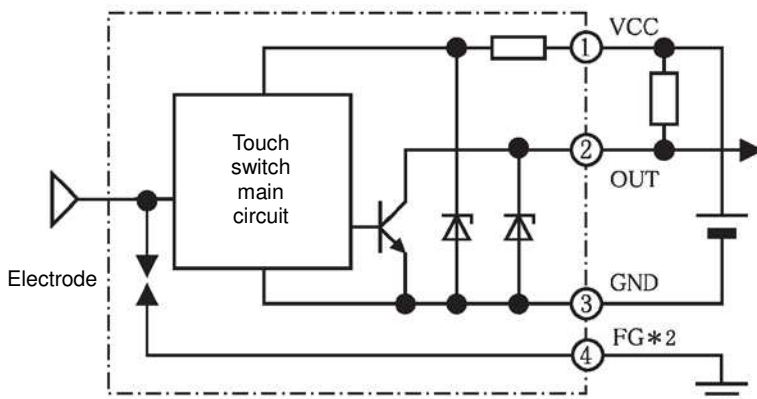

\*2. You are recommended to connect the FG terminal to the area of stable electric potential including the frame ground in the machine. When not using the FG terminal, connect it to GND.

## ■ Operation chart

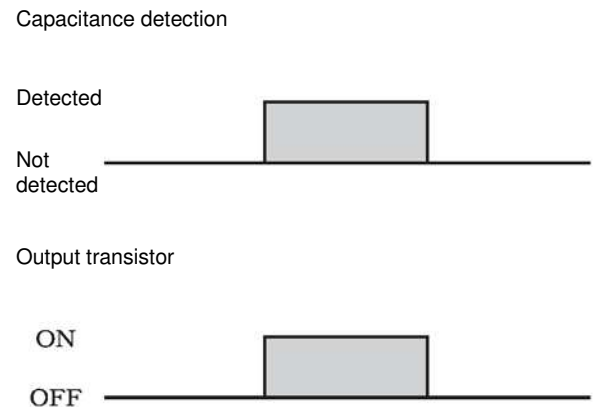

## Exterior dimensions

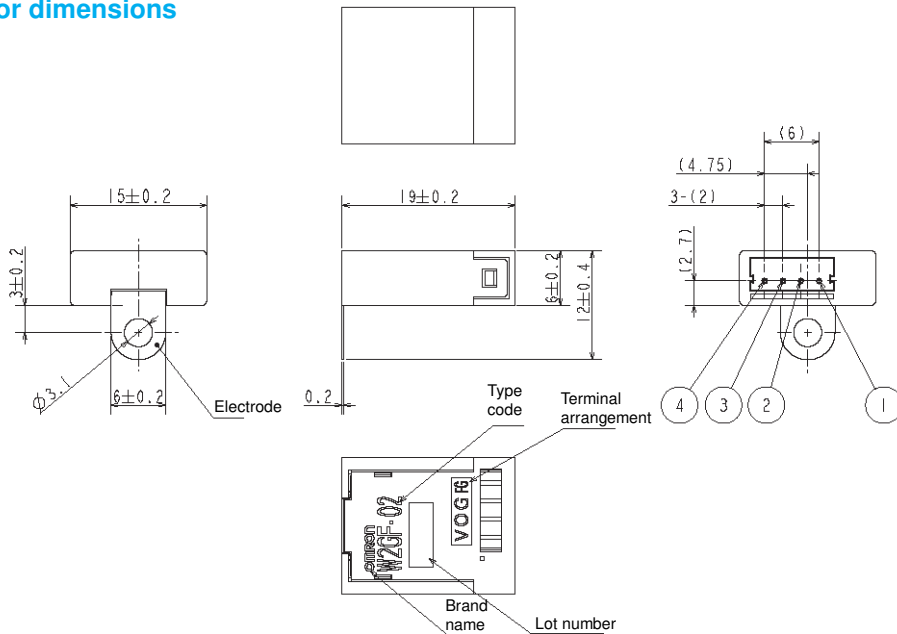

Note 1. The relationship between the terminal numbers and symbols are shown below.

Terminal No.	Terminal symbol
1	VCC
2	OUT
3	GND
4	FG

2. The housing compatible with the connector shall be Type 51065-040□ series made by Molex Japan LLC.

\* Unless otherwise specified, the dimensional tolerance shall be IT16. [Unit: mm]

## About usage

### (1) Usage

The touch switch incorporating the specifications required in each application is available by making the electrode of this product come into contact with the member (made of metal material or metal plated member) for touch switch and fixing it. The through-hole in the electrode allows its attachment with a screw.

### (2) FG terminal

Due to the characteristics of touch switches, static electricity of human body may intrude into a touch switch through the electrode. The FG terminal is provided as the path for discharging the static electricity.

To effectively use the FG terminal as anti-static measure, you are recommended to connect the terminal to the area of stable electric potential including the frame ground in the machine with thick and short wiring. When not using the FG terminal, connect it to GND.

## Precautions for use

- (1) As the touch switch member, use a conductive member including metal member and metal plated member.
- (2) Be sure to insulate the touch switch member and the electrode of this product from the earthing conductor.
- (3) Depending on the conditions including the size of the touch switch member and its surrounding metals, the regularly applied capacitance differs. Before using the product, check that the applied capacitance is equal to or smaller than the rated detection capacitance with the touch switch member attached.
- (4) Do not apply stress that causes the bending of the electrode during use.

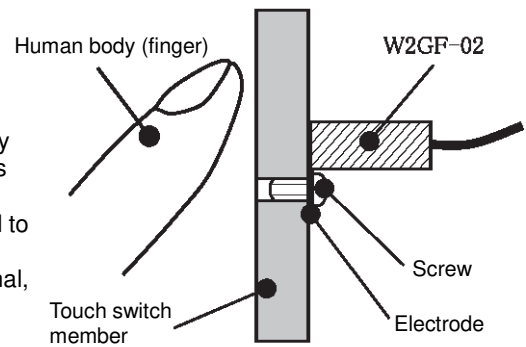

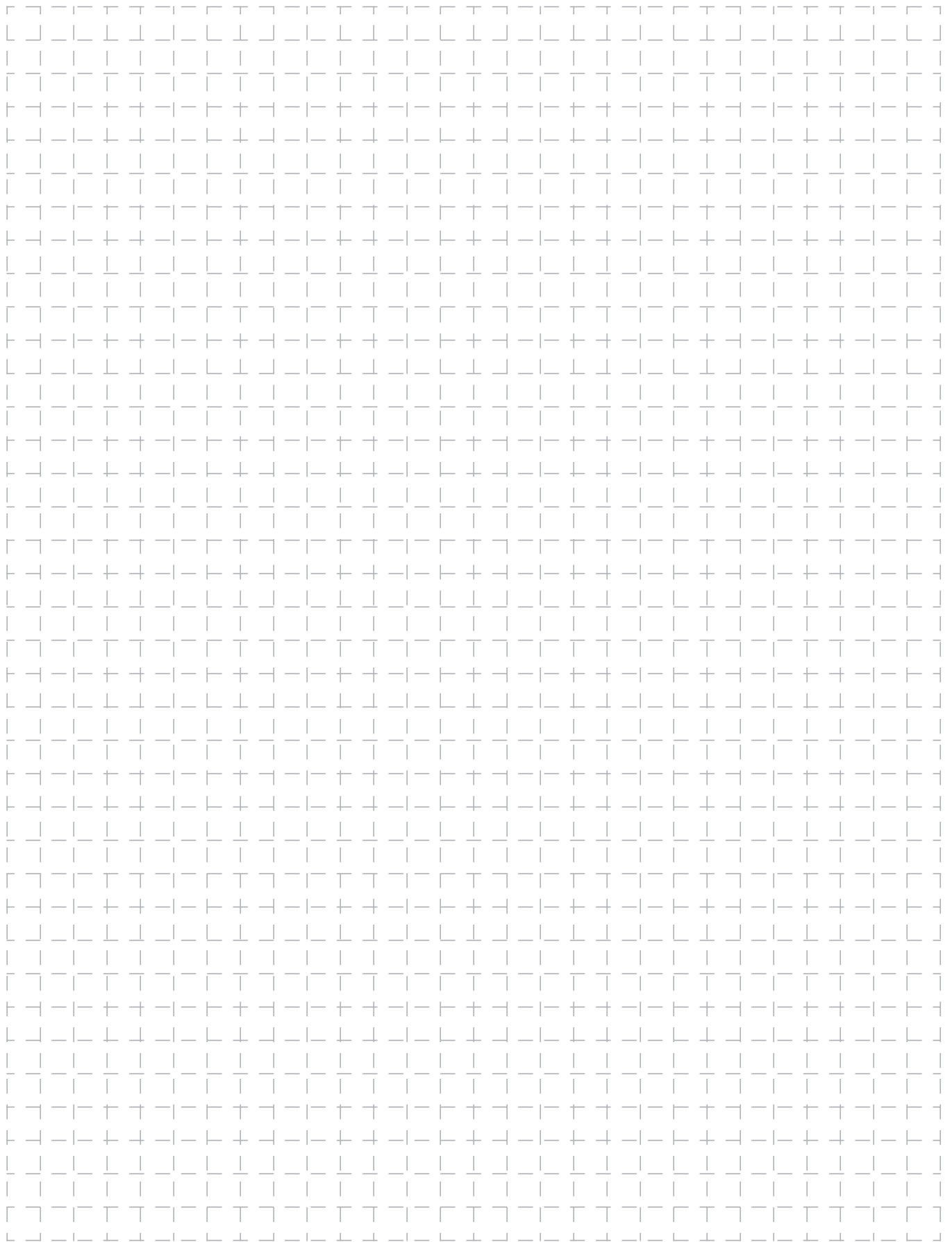



All sales are subject to Omron Electronic Components LLC standard terms and conditions of sale, which can be found at [http://www.components.omron.com/components/web/webfiles.nsf/sales\\_terms.html](http://www.components.omron.com/components/web/webfiles.nsf/sales_terms.html)

**ALL DIMENSIONS SHOWN ARE IN MILLIMETERS.**  
To convert millimeters into inches, multiply by 0.03937. To convert grams into ounces, multiply by 0.03527.

---

**OMRON**<sup>®</sup>  
**OMRON ELECTRONIC  
COMPONENTS LLC**  
**847-882-2288**

**OMRON ON-LINE**

Global - <http://www.omron.com>  
USA - <http://www.components.omron.com>