



Chipsmall Limited consists of a professional team with an average of over 10 year of expertise in the distribution of electronic components. Based in Hongkong, we have already established firm and mutual-benefit business relationships with customers from,Europe,America and south Asia,supplying obsolete and hard-to-find components to meet their specific needs.

With the principle of “Quality Parts,Customers Priority,Honest Operation,and Considerate Service”,our business mainly focus on the distribution of electronic components. Line cards we deal with include Microchip,ALPS,ROHM,Xilinx,Pulse,ON,Everlight and Freescale. Main products comprise IC,Modules,Potentiometer,IC Socket,Relay,Connector.Our parts cover such applications as commercial,industrial, and automotives areas.

We are looking forward to setting up business relationship with you and hope to provide you with the best service and solution. Let us make a better world for our industry!



Contact us

Tel: +86-755-8981 8866 Fax: +86-755-8427 6832

Email & Skype: info@chipsmall.com Web: www.chipsmall.com

Address: A1208, Overseas Decoration Building, #122 Zhenhua RD., Futian, Shenzhen, China



Winbond W681388

Single Programmable Extended CODEC/SLIC

The W681388 implements a single channel FXS telephone line interface optimized for short loop applications. It integrates SLIC (Subscriber Line Interface Circuit) functionality with a programmable CODEC and a DC-to-DC controller. The SLIC supports internal ringing up to 90 V_{PK} (5 REN at 4 kft), ideal for customer premise equipment (CPE). The CODEC can be configured for μ -law/A-law or 16-bit linear PCM encoding and supports a comprehensive set of signaling capabilities required to supervise and control both telephone lines. These include tone generation (including ring tones), DTMF generation and detection as well as FSK and metering pulse generation. An on-chip pulse width modulation (PWM) driver allows the control of DC-to-DC conversion for the line. Programmable impedance and transhybrid balancing allow for worldwide deployment.

APPLICATIONS

- Analog Telephone Adapter
- Voice enabled DSL Modems
- Voice enabled Cable Modems
- Residential VoIP Gateways / Routers
- Integrated Access Devices
- Fiber to the Premise/Home (FTTP/H)
- Optical Network Terminals (ONT)
- Set Top Boxes
- Wireless Local Loop
- PBX

FEATURES

- Performs complete BORSCHT functions for a single channel with a single device
- Internal balanced ringing up to 90V_{PK} (5REN up to 4kft)
- Integrated Power Management
 - Integrated DC-DC controller regulates battery voltage to minimize power dissipation in all operating modes
- Programmable linefeed characteristics
 - Ringing frequency, amplitude, cadence
 - Trapezoidal and Sinusoidal waveforms
 - Two-wire AC impedance, transhybrid balance
 - Constant Current feed (20 to 41mA)
 - Ring trip and loop closure thresholds
- Programmable signal generation
 - DTMF generation and detection
 - Metering pulse generation (12/16kHz)
 - Enhanced Caller ID (FSK) generation (Type I and Type II)
 - Tone generation (up to four simultaneous)
 - G.711 μ -Law/A-Law / 16-bit linear PCM audio
- Loop test and diagnostics support
 - Integrated loopback modes
 - Realtime linefeed monitoring
 - On-chip temperature sensor
- PCM and SPI bus digital interfaces
 - PCM Master and Slave modes supported
- On-chip PLL for flexible clocking options including 1MHz / 2MHz
- 3.3V operation
- Small Footprint Packages: LQFP-48, QFN-48

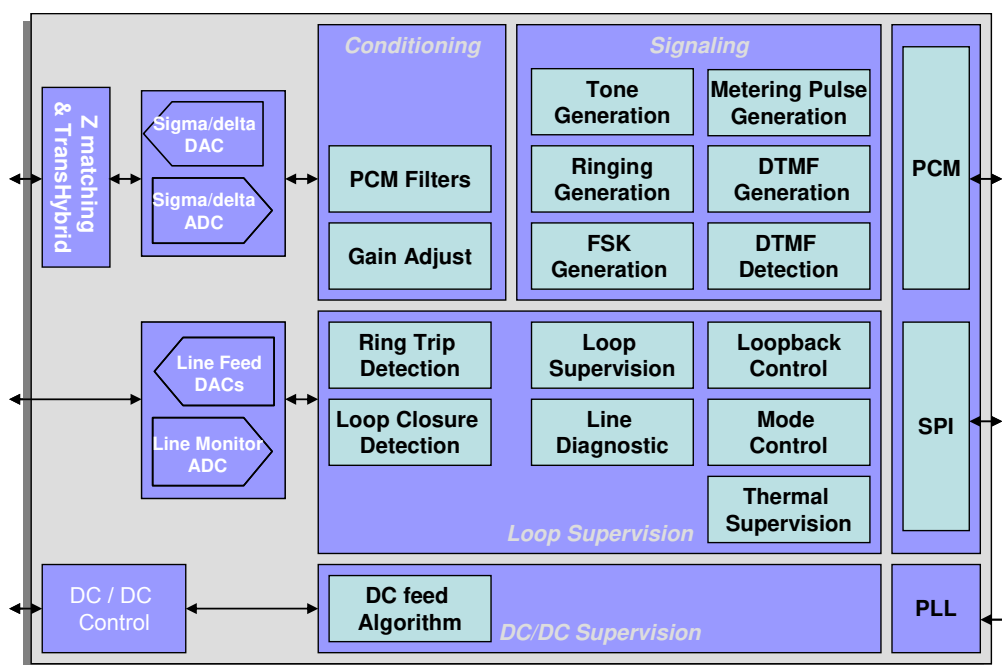

Application Example: Analog Telephone Adapter (ATA) supporting 1 voice port

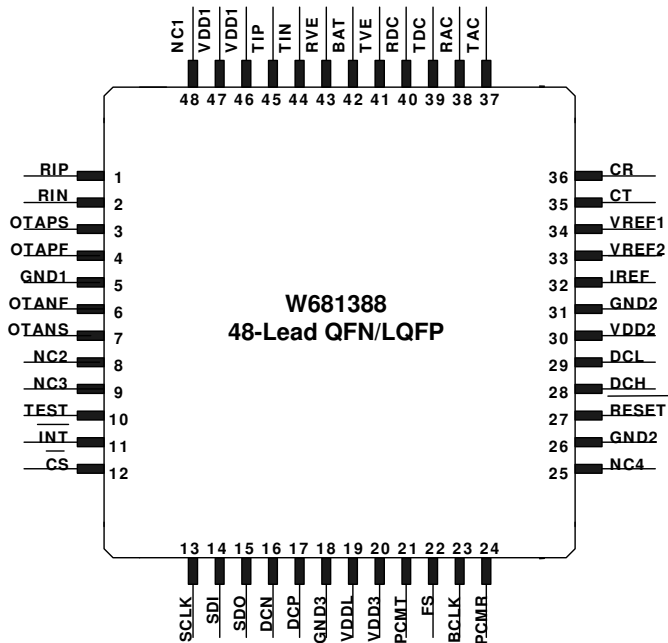
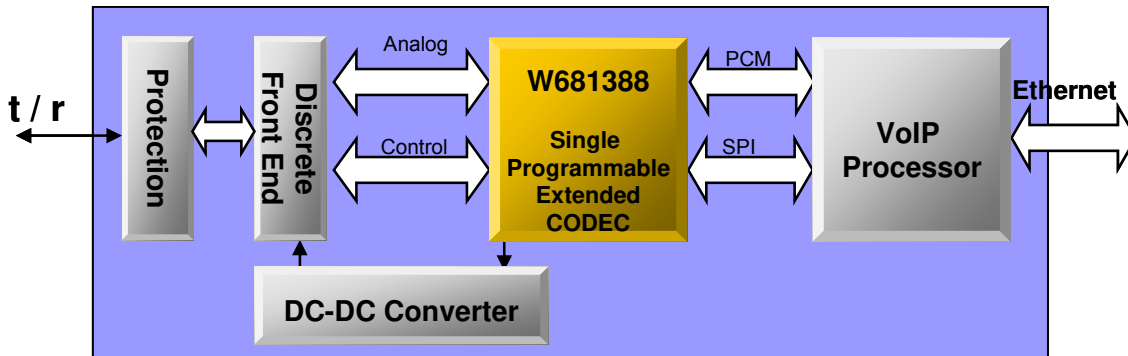

BENEFITS

- High integration reduces overall system BOM and footprint
- Low power consumption for battery-backup and other power sensitive applications
- High programmability reduces real-time software overhead
- Extensive line sensing enables diagnostics support

W681388 ORDERING INFORMATION

| Part Number | Package | Notes |
|-------------|---------|---------|
| W681388DG | LQFP-48 | Pb-Free |
| W681388YG | QFN-48 | Pb-Free |

Note: For more details on the W681388, please refer to Winbond America's web site at: <http://www.winbond-usa.com>



Winbond is a registered trademark of Winbond Electronics Corporation. All other trademarks and logos are the properties of their respective owners.

Winbond Electronics Corporation America

2727 North First Street
San Jose, CA 95134, U.S.A.
TEL: 1-408-474-1612 (Americas)
TEL: 1-408-474-1671 (Europe)
FAX: 1-408-544-1787

Winbond Electronics (Shanghai) Ltd./Shenzhen

15F, New World Commercial Center
6009 Yi Tian Road
Fu Tian District, Shenzhen, P.R. China
TEL: 86-755-83515350
FAX: 86-755-83515348

Winbond Electronics Japan

No. 2 Ueno-Bldg., 7-18, 3-chome
Shinyokohama Kouhoku-ku
Yokohama-shi, 222-0033 Japan
TEL: 81-45-4781881
FAX: 81-45-4781800

Winbond Electronics (H.K.) Ltd.

Unit 9-15, 22F, Millennium City 2,
378 Kwung Tong Rd.
Kowloon, Hong Kong
TEL: 852-27513100
FAX: 852-27552064

Winbond Electronics (Taipei)

9F, No. 480, Rueiguang Rd.
Neihu Chiu
Taipei, 114, Taiwan
TEL: 886-2-81777168
FAX: 886-2-87153579

Winbond Electronics Ltd.

27F, 2299 Yan An Road (West)
Shanghai, P.R. China 200336
TEL: 86-21-62365999
FAX: 86-21-62365998