



Chipsmall Limited consists of a professional team with an average of over 10 year of expertise in the distribution of electronic components. Based in Hongkong, we have already established firm and mutual-benefit business relationships with customers from,Europe,America and south Asia,supplying obsolete and hard-to-find components to meet their specific needs.

With the principle of “Quality Parts,Customers Priority,Honest Operation,and Considerate Service”,our business mainly focus on the distribution of electronic components. Line cards we deal with include Microchip,ALPS,ROHM,Xilinx,Pulse,ON,Everlight and Freescale. Main products comprise IC,Modules,Potentiometer,IC Socket,Relay,Connector.Our parts cover such applications as commercial,industrial, and automotives areas.

We are looking forward to setting up business relationship with you and hope to provide you with the best service and solution. Let us make a better world for our industry!



Contact us

Tel: +86-755-8981 8866 Fax: +86-755-8427 6832

Email & Skype: info@chipsmall.com Web: www.chipsmall.com

Address: A1208, Overseas Decoration Building, #122 Zhenhua RD., Futian, Shenzhen, China



Winbond's W681512 Single-Channel CODEC

The W681512 single channel voice CODEC is an analog-to-digital and digital-to-analog converter that complies with ITU-T G.712 specifications. The CODEC features complete μ -Law and A-Law companders (pin selectable) that are designed to comply with ITU-T G.711 specifications. The chip also offers a fully differential analog output.

In order to provide the cleanest possible signal, the W681512 CODEC complies with the ITU-T G.712 recommendation for analog-to-digital pre-filters (also known as anti-aliasing filters) and Digital-to-Analog post filter (signal smoothing filter).

The W681512 CODEC contains an additional analog power amplifier that drives higher current output. The power amplifier gain levels can be adjusted via a set of external resistors to drive an output level of up to 6.3V, peak-to-peak, across a 300- Ω load.

The PCM interface for the W681512 produces 8-bit digital data (μ -Law or A-Law) at a sampling rate of 8kHz. It can communicate in four different clock formats; short frame sync, long frame sync, IDL and CGI. The W681512 is available in 20-pin SOP and SSOP packaging.

For evaluation and prototyping purposes, a development kit, the W681512DK, is available to provide the system designer with a flexible method for developing and testing an application on a single, standalone platform.

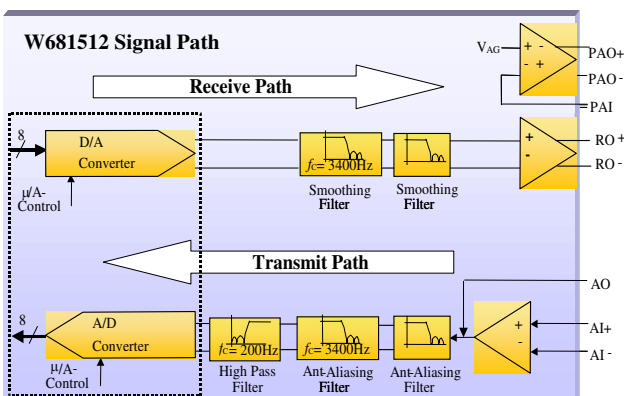

Preliminary Product Bulletin

Features

- Single supply voltage: 4.5 - 5.5V
- Typical power dissipation: 30mW, power-down of 0.5 μ W
- Fully-differential analog circuit design
- Differential outputs
- On-chip precision reference voltage of 1.575V for a 0dBm TLP @ 600 Ω
- Push-pull 300 Ω power drivers with external gain adjust
- 8 kHz sample rate
- Master clock rates: 256 kHz, 512 kHz, 1536 kHz, 1544 kHz, 2048 kHz, 2560 kHz and 4096 kHz
- Pin-selectable μ -Law and A-Law companding (full compliance with ITU-T G.711)
- CODEC A/D and D/A filter compliance with ITU-T G.712 specifications
- PCM interface: Short Frame Sync, Long Frame Sync, IDL and GCI timing environments
- Temperature range: Industrial grade (-40 $^{\circ}$ C to 85 $^{\circ}$ C)
- Packaging: 20-pin SOP

Benefits

- Low power competitive solution
- System level customization
- Cross references with the Motorola[®] MC145480 & MC14LC5480

CODEC Applications

- VoIP, Voice over Networks
- PBX systems (gateways, switches)
- PABX/SOHO systems
- Local loop card
- SOHO routers
- Fiber-to-curb equipment
- Enterprise phones
- Digital telephone systems
- ISDN equipment
- Modems/PC cards

Development System

- The W681512DK is a development kit that can be configured in one of the following two modes:
 - **Stand alone** - capable of demo a loop back and prototype a design on a dedicated board space
 - **Back-to-Back** -enables full system test between two platforms

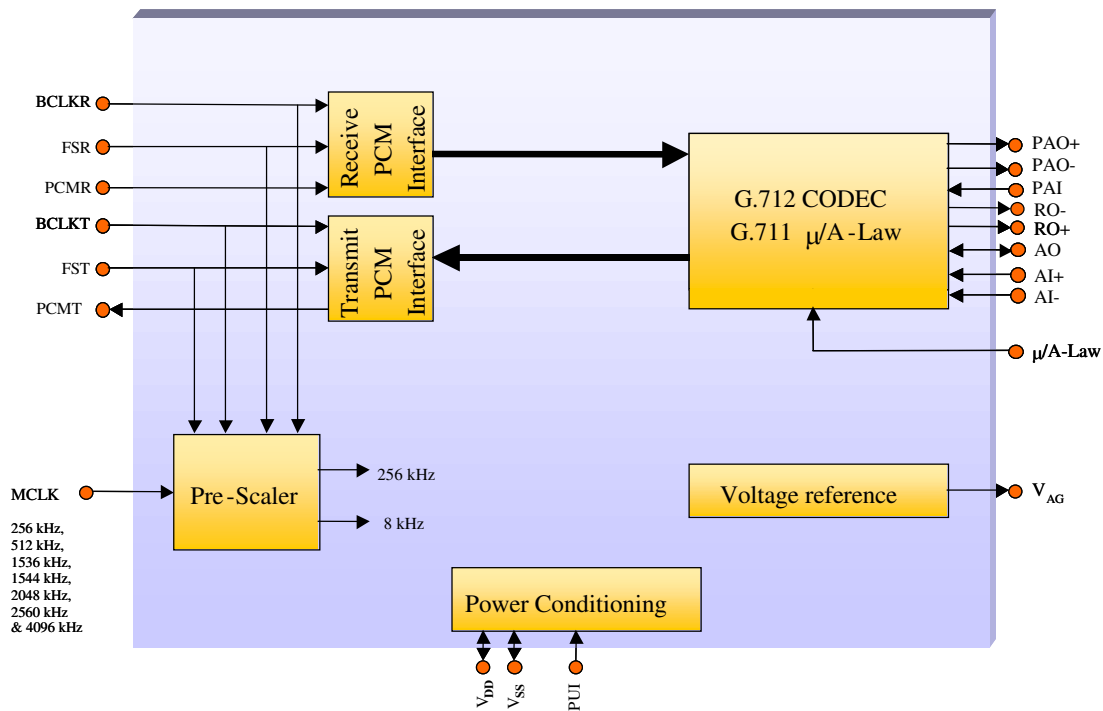

W681512 Block Diagram

Pin #	Pin Name	Functionality
1	RO+	Non-Inverting Receive output
2	RO-	Inverting Receive output
3	PAI	Power amplifier inverted input
4	PAO-	Inverting Power Amplifier output
5	PAO+	Non-Inverting Power Amplifier output
6	V_{DD}	Positive power supply
7	FSR	Receive Frame Sync input
8	PCMR	PCM input data receive
9	BCLKR	Receive bit clock input
10	PUI	Power up indicator
11	MCLK	System master clock input
12	BCLKT	Transmit bit clock input
13	PCMT	PCM output data transmit pin
14	FST	Transmit Frame Sync input
15	V_{SS}	Ground power supply
16	μ/A -Law	μ -Law /A-Law companding select pin
17	AO	Transmit gain output
18	AI-	Inverting Transmit input
19	AI+	Non-Inverting Transmit input
20	V_{AG}	Analog signal reference ground output

RO+	1	20	V_{AG}
RO-	2	19	AI+
PAI	3	18	AI-
PAO-	4	17	AO
PAO+	5	16	μ/A -Law
V_{DD}	6	15	V_{SS}
FSR	7	14	FST
PCMR	8	13	PCMT
BCLKR	9	12	BCLKT
PUI	10	11	MCLK

SINGLE CHANNEL CODEC
SOP/SSOP

To order products or for more information:

Winbond Electronics Corporation America
 2727 N. First Street
 San Jose, CA 95134
 Tel: 1-800-677-0769 (U.S. Only), 408-943-6666
 Fax: 408-544-1789
 e-mail: info@winbond-usa.com
 Web: www.winbond-usa.com

Note: For more details on Winbond's W681512 please refer to the product datasheet.

Winbond is a registered trademark of Winbond Electronics Corporation. All other trademarks and logos are the properties of their respective owners. Winbond CIDPB1-0901