



Chipsmall Limited consists of a professional team with an average of over 10 year of expertise in the distribution of electronic components. Based in Hongkong, we have already established firm and mutual-benefit business relationships with customers from,Europe,America and south Asia,supplying obsolete and hard-to-find components to meet their specific needs.

With the principle of “Quality Parts,Customers Priority,Honest Operation,and Considerate Service”,our business mainly focus on the distribution of electronic components. Line cards we deal with include Microchip,ALPS,ROHM,Xilinx,Pulse,ON,Everlight and Freescale. Main products comprise IC,Modules,Potentiometer,IC Socket,Relay,Connector.Our parts cover such applications as commercial,industrial, and automotives areas.

We are looking forward to setting up business relationship with you and hope to provide you with the best service and solution. Let us make a better world for our industry!



Contact us

Tel: +86-755-8981 8866 Fax: +86-755-8427 6832

Email & Skype: info@chipsmall.com Web: www.chipsmall.com

Address: A1208, Overseas Decoration Building, #122 Zhenhua RD., Futian, Shenzhen, China





Winbond
ACPI-STR Controller
W83305S
W83305G



W83305S

Data Sheet Revision History

	PAGES	DATES	VERSION	VERSION ON WEB	MAIN CONTENTS
1		Apr./06	0.5	N.A.	All version before 0.5 are for internal use only

Please note that all data and specifications are subject to change without notice. All the trademarks of products and companies mentioned in this datasheet belong to their respective owners.

LIFE SUPPORT APPLICATIONS

These products are not designed for use in life support appliances, devices, or systems where malfunction of these products can reasonably be expected to result in personal injury. Winbond customers using or selling these products for use in such applications do so at their own risk and agree to fully indemnify Winbond for any damages resulting from such improper use or sales.



Table of Contents-

1.	GENERAL DESCRIPTION	1
2.	FEATURES	1
3.	PIN CONFIGURATION	1
4.	PIN DESCRIPTION.....	2
5.	REGISTER DESCRIPTION	3
5.1	CR01 (VAGP Over-clocking Configuration Register, Default 0x00h, Read/Write)	3
5.2	CR02 (VRAM Over-clocking Configuration Register, Default 0x00h, Read/Write).....	3
5.3	Index 4Ch - Winbond Vendor ID (Low Byte)	4
5.4	Index 4Dh - Winbond Vendor ID (High Byte)	4
5.5	Chip ID -- Index 4Eh	4
5.6	Reversion ID -- Index 4Fh.....	4
6.	APPLICATION CIRCUIT.....	5
7.	INTERNAL BLOCK DIAGRAM	5
8.	ELECTRICAL CHARACTERISTICS.....	6
9.	PACKAGE SPECIFICATION	7
10.	ORDERING INFORMATION	8
11.	HOW TO READ THE TOP MARKING.....	8



1. GENERAL DESCRIPTION

W83305S is a new power management IC which compliant ACPI specification 2.0 for desktop PC and motherboard. The chip regulates two most voltage-relative powers for DDR SDRAM and AGP slot applications. As the two devices on board, a stable, reliable, and programmable power should be performed for higher reliability, stability, compatibility and better-performance for diverse combination of devices (RAM module and AGP card). The chip is operated basing on a simple dual-wire bus SMBus. Via SMBus control, the power for DDR SDRAM can be adjusted ranging from 2.50V to 3.00V; and the power for AGP slot can be adjusted ranging from 1.50V to 2.00V with 50mV/step. Besides for safety consideration, linear under voltage and soft-start are applied on the two regulated powers. With design of W83305S, a **cost-effective, sample, modular, stable, reliable, flexible** and **high-performance** power solution is provides for the motherboard and desktop PC design.

2. FEATURES

- Provides ACPI-Compliant Voltages
 - Programmable 2.55V_{STR} Power for DDR SDRAM
 - Programmable 1.55V_{CC} Power for AGP Slot
- I2C Interface
- Internal Charge Pump Support Voltage Up to 9.5V
- Drive All N-Channel MOSFET
- Soft Start
- Under-Voltage Protection for VAGP, VRAM
- Small footprint package 14-SOP 150mil

3. PIN CONFIGURATION

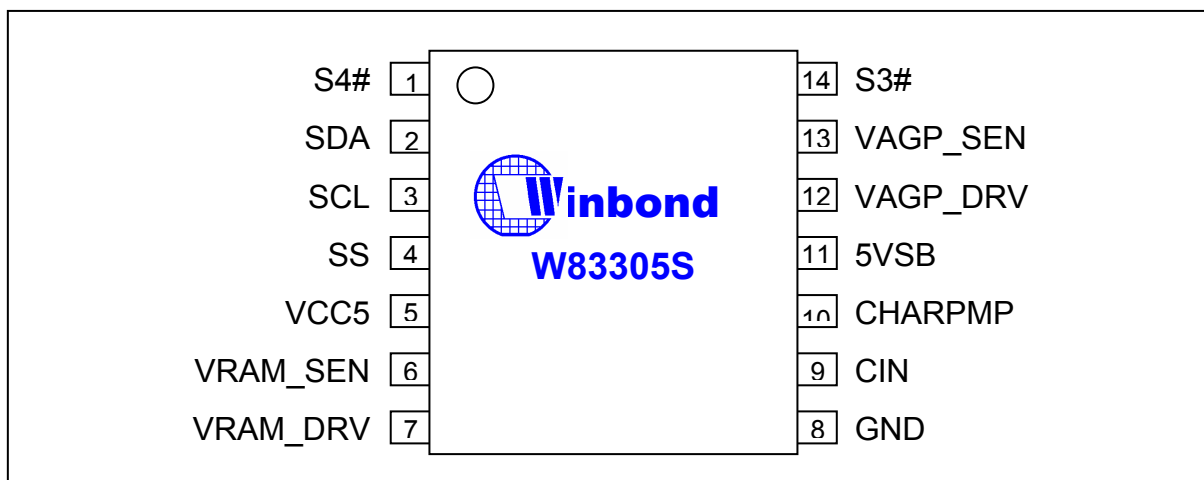



4. PIN DESCRIPTION

NO	NAME	I/O	FUNCTION DESCRIPTION
1	S4#	I _{ST}	ACPI control signal.
2	SDA	I/O	I2C Interface Pins. The address is defined as 5EH (0101 111X), and X is used to control read/write.
3	SCL	I	
4	SS	I	Soft-Start Pin. Attach an external capacitor (0.1u) on this pin to adjust the soft-start slope-rate.
5	VCC5	I _{ST}	Power VCC5 Input.
6	VRAM_SEN	I	Linear Regulator for DDR SDRAM.
7	VRAM_DRV	O	
8	GND	P	Power Ground.
9	C _{IN}	I	Charge Pump Pins. It supports 5mA driving current and insures output voltage 10V or above.
10	CHRPMP	P	
11	5VSB	P	Power Pin.
12	VAGP_DRV	O	Linear Regulator for AGP slot.
13	VAGP_SEN	I	
14	S3#	I _{ST}	ACPI Control Signal.



5. REGISTER DESCRIPTION

5.1 CR01 (VAGP Over-clocking Configuration Register, Default 0x00h, Read/Write)

BIT0	BIT1	BIT2	V _{AGP} OUTPUT (V)
0	0	0	1.55
0	0	1	1.50
0	1	0	1.60
0	1	1	1.65
1	0	0	1.70
1	0	1	1.80
1	1	0	1.90
1	1	1	2.00

5.2 CR02 (VRAM Over-clocking Configuration Register, Default 0x00h, Read/Write)

BIT0	BIT1	BIT2	V _{RAM} OUTPUT (V)
0	0	0	2.55
0	0	1	2.50
0	1	0	2.60
0	1	1	2.65
1	0	0	2.70
1	0	1	2.80
1	1	0	2.90
1	1	1	3.00

CR03 (Linear Under Voltage Enable/Disable Register, Default 0x03h, Read/Write)

Bit1: Linear under voltage protection enable/disable bit for V_{AGP}

0: Disable 1: Enable

Bit0: Linear under voltage protection enable/disable bit for V_{RAM}

0: disable 1: Enable



5.3 Index 4Ch - Winbond Vendor ID (Low Byte)

Power-on default [7:0] = 1010, 0011 b (A3h)

BIT	NAME	READ/WRITE	DESCRIPTION
7:0	VIDL[7:0]	Read Only	Vendor ID Low Byte. Default A3h.

5.4 Index 4Dh - Winbond Vendor ID (High Byte)

Power-on default [7:0] = 0101, 1100 b (5Ch)

BIT	NAME	READ/WRITE	DESCRIPTION
7:0	VIDH[7:0]	Read Only	Vendor ID High Byte. Default 5Ch

5.5 Chip ID -- Index 4Eh

Power on default [7:0] = 1010, 0000 b

BIT	NAME	READ/WRITE	DESCRIPTION
7:0	CHIPID[7:0]	Read Only	Winbond Chip ID number. Read this register will return 0xa0h for W83305S.

5.6 Reversion ID -- Index 4Fh

Power on default [7:0] = 0000, 0000 b

BIT	NAME	READ/WRITE	DESCRIPTION
7:0	CHIPID[7:0]	Read Only	Winbond Chip ID number. Read this register will return 0x00h for W83305S.



6. APPLICATION CIRCUIT

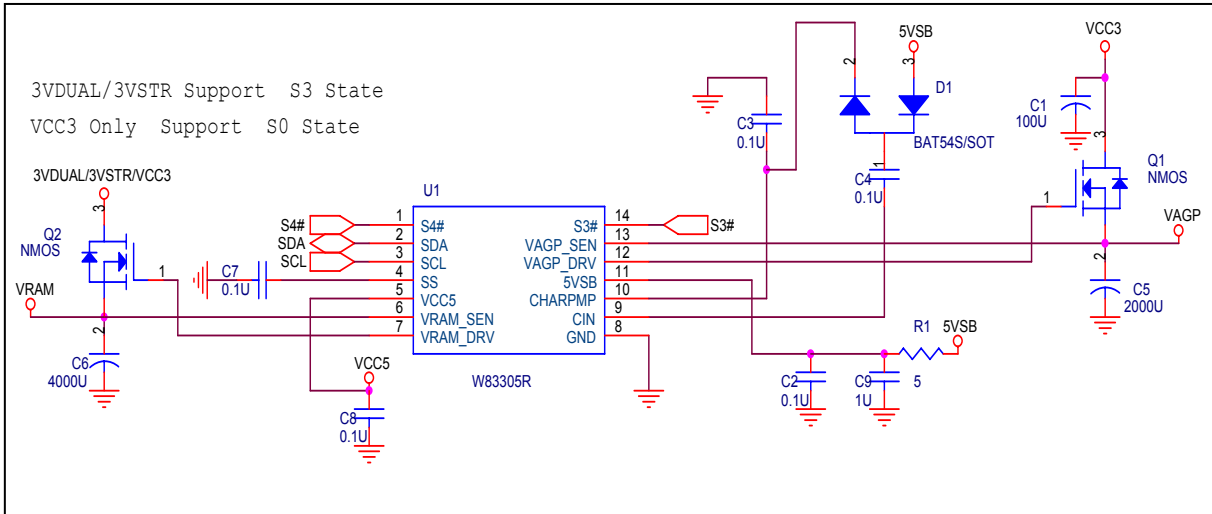

7. INTERNAL BLOCK DIAGRAM

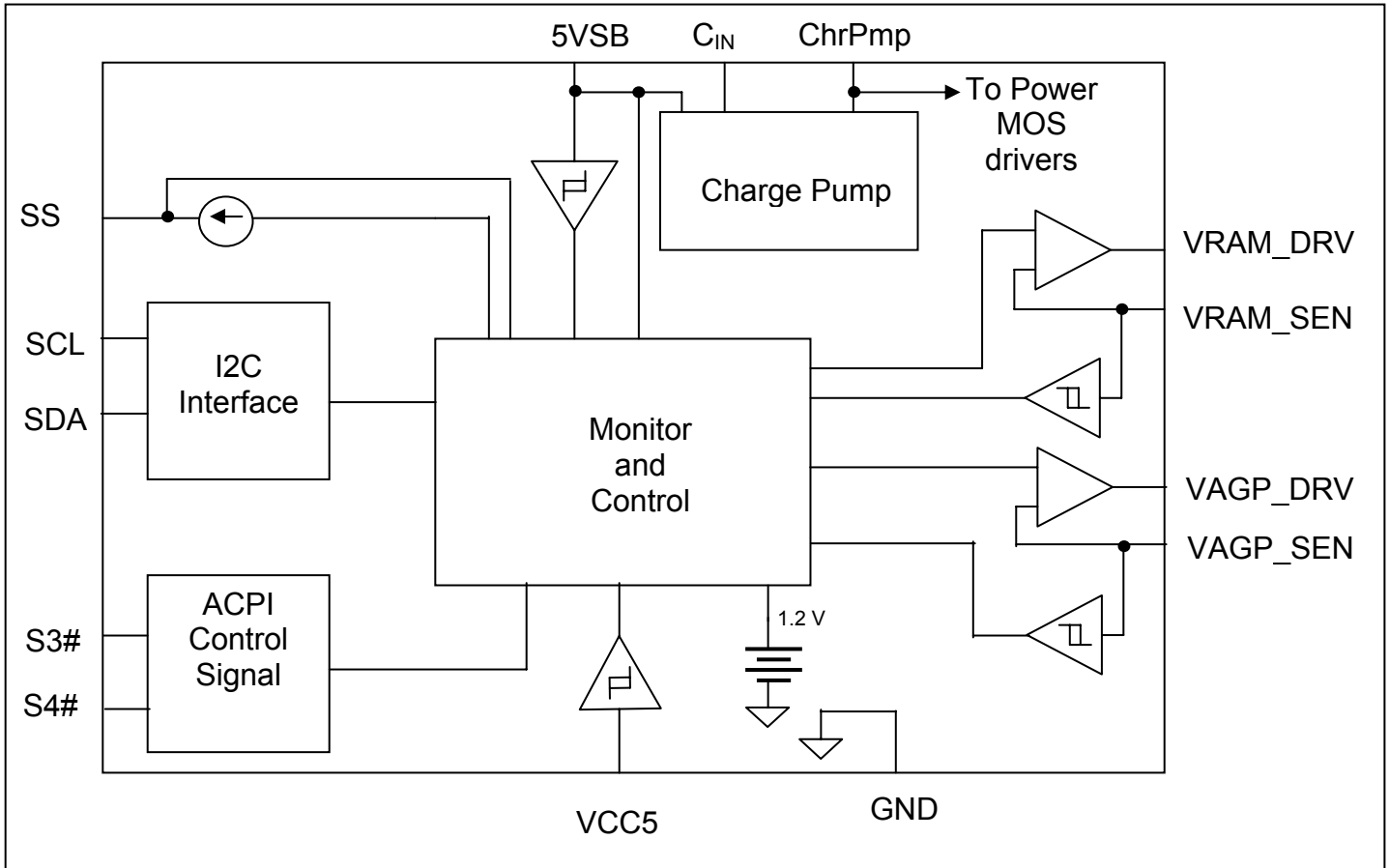



8. ELECTRICAL CHARACTERISTICS

AC Characteristics

VCC=5V ± 5 %, T _A = 0°C TO +70°C						
PARAMETER	SYMBOL	MIN	TYP	MAX	UNITS	TEST CONDITIONS
VAGP REGULATOR 0						
Nominal Output Voltage			1.55		V	CR01(bit0,bit1,bit2)=000
Nominal Output Voltage			1.50		V	CR01(bit0,bit1,bit2)=001
Nominal Output Voltage			1.60		V	CR01(bit0,bit1,bit2)=010
Nominal Output Voltage			1.65		V	CR01(bit0,bit1,bit2)=011
Nominal Output Voltage			1.70		V	CR01(bit0,bit1,bit2)=100
Nominal Output Voltage			1.80		V	CR01(bit0,bit1,bit2)=101
Nominal Output Voltage			1.90		V	CR01(bit0,bit1,bit2)=110
Nominal Output Voltage			2.00		V	CR01(bit0,bit1,bit2)=111
Regulation				5	%	
Under-Voltage Falling Threshold			73.3 %		%	
VAGP_DRV Output Voltage		8			V	CR0F=80h I(VAGP_DRV) < 0.1mA
VRAM2.5 REGULATOR						
Nominal Output Voltage			2.55		V	CR02(bit0,bit1,bit2)=000
Nominal Output Voltage			2.50		V	CR02(bit0,bit1,bit2)=001
Nominal Output Voltage			2.60		V	CR02(bit0,bit1,bit2)=010
Nominal Output Voltage			2.65		V	CR02(bit0,bit1,bit2)=011
Nominal Output Voltage			2.70		V	CR02(bit0,bit1,bit2)=100
Nominal Output Voltage			2.80		V	CR02(bit0,bit1,bit2)=101
Nominal Output Voltage			2.90		V	CR02(bit0,bit1,bit2)=110
Nominal Output Voltage			3.00		V	CR02(bit0,bit1,bit2)=111
Regulation				5	%	
Under-Voltage Falling Threshold			76%		%	
MAX VRAM_2.5_DRV Output Voltage		8			V	I(VRAM_2.5_DRV) < 0.1mA

CHARGE PUMP						
Charge Pump Frequency		160	200	240	KHz	
Charge Pump Voltage		9.2	9.5			

LOGIC LEVEL	HIGH		LOW
S3	2.55±0.3V	2.55±0.3V	
S4	2.55±0.3V	2.55±0.3V	



9. PACKAGE SPECIFICATION

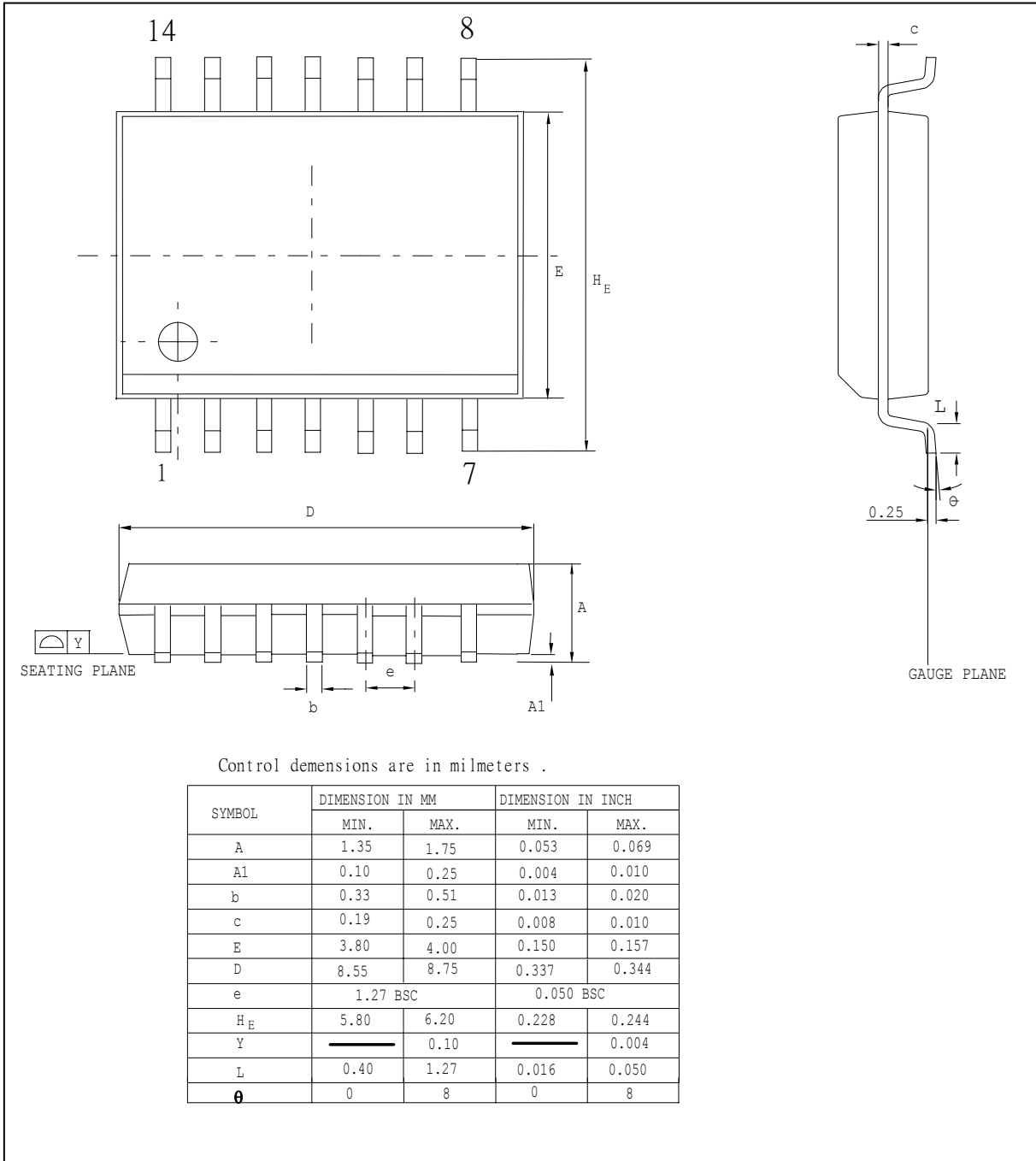

W83305S/W83305G



10. ORDERING INFORMATION

PART NO.	PACKAGE	REMARKS
W83305S	14-SSOP	Operation - Commercial 0~70°C
W83305G	14 SSOP	Operation - Commercial 0~70°C PB-free package

11. HOW TO READ THE TOP MARKING

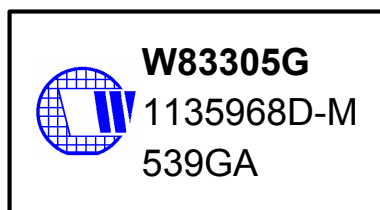
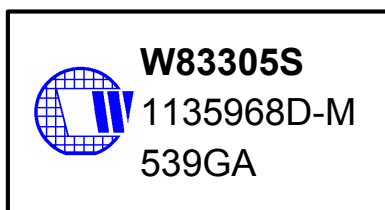

Left Line: Winbond Logo

1st Line: IC Part No - W83305S,W83305G(Pb-free package)

2nd Line: IC Lot No – XXXXXXXX

3rd Line: Assembly Date (X: Assembly Year + XX: Assembly Week) + Assembly House Code (G- GR; O- OSE; A- ASE, etc...) + IC Version (X)

W83305S/W83305G



Please note that all data and specifications are subject to change without notice. All the trade marks of products and companies mentioned in this data sheet belong to their respective owners.

Important Notice

Winbond products are not designed, intended, authorized or warranted for use as components in systems or equipment intended for surgical implantation, atomic energy control instruments, airplane or spaceship instruments, transportation instruments, traffic signal instruments, combustion control instruments, or for other applications intended to support or sustain life. Further more, Winbond products are not intended for applications wherein failure of Winbond products could result or lead to a situation wherein personal injury, death or severe property or environmental damage could occur.

Winbond customers using or selling these products for use in such applications do so at their own risk and agree to fully indemnify Winbond for any damages resulting from such improper use or sales.

*Please note that all data and specifications are subject to change without notice.
All the trademarks of products and companies mentioned in this datasheet belong to their respective owners.*