



Chipsmall Limited consists of a professional team with an average of over 10 year of expertise in the distribution of electronic components. Based in Hongkong, we have already established firm and mutual-benefit business relationships with customers from,Europe,America and south Asia,supplying obsolete and hard-to-find components to meet their specific needs.

With the principle of "Quality Parts,Customers Priority,Honest Operation,and Considerate Service",our business mainly focus on the distribution of electronic components. Line cards we deal with include Microchip,ALPS,ROHM,Xilinx,Pulse,ON,Everlight and Freescale. Main products comprise IC,Modules,Potentiometer,IC Socket,Relay,Connector.Our parts cover such applications as commercial,industrial, and automotives areas.

We are looking forward to setting up business relationship with you and hope to provide you with the best service and solution. Let us make a better world for our industry!



Contact us

Tel: +86-755-8981 8866 Fax: +86-755-8427 6832

Email & Skype: info@chipsmall.com Web: www.chipsmall.com

Address: A1208, Overseas Decoration Building, #122 Zhenhua RD., Futian, Shenzhen, China



W83775G
Nuvoton
H/W Monitoring IC

DATE: 25TH, JANUARY, 2010

REVISION: 1.4

TABLE OF CONTENTS-

1. GENERAL DESCRIPTION 1

 1.1 Product Selection Guide 1

2. FEATURES 2

 2.1 Monitoring Items - Temperature 2

 2.2 General 2

 2.3 Applications..... 2

3. KEY SPECIFICATIONS 3

4. BLOCK DIAGRAM 3

5. PIN CONFIGURATION 4

6. PIN DESCRIPTION..... 5

7. FUNCTIONAL DESCRIPTION..... 6

 7.1 General Description 6

 7.2 Access Interface 7

 7.3 \overline{ALERT} Output Mode 8

 7.3.1 \overline{ALERT} Output Comparator Mode 8

 7.3.2 \overline{ALERT} Output Interrupt Mode..... 8

 7.3.3 \overline{ALERT} Output SMBus ALERT Mode 10

 7.4 $\overline{T_CRIT_A}$ Output and T_CRIT flags 11

 7.5 Measured Temperature Data Format 12

 7.5.1 Measure Remote Temperature Data Format..... 12

 7.5.2 Measure Local Temperature Data Format..... 12

 7.6 Digital Filter 13

 7.7 Fault Detect..... 14

 7.8 Conversion Rate and Moving Average 14

8. CONTROL AND STATUS REGISTER 15

 8.1 W83775G Registers 15

8.2	Data Format of Temperature Registers	17
8.3	Status Register (SR1)	18
8.4	Status Register 2 (SR2)	18
8.5	Configuration Register (C1)	19
8.6	Configuration Register 2 (C2)	19
8.7	T_CRIT Hysteresis Register (TH)	19
8.8	Conversion Rate Register (CR)	20
8.9	Filter and Alert Configure Register (RDTFA, RDTFB)	21
8.10	Ideality (IDEAA, IDEAB)	21
8.11	Remote Temperature B Enable (RTBE) *for W83775G-2 only.	22
9.	ELECTRICAL CHARACTERISTIC	23
9.1	Absolute Maximum Ratings	23
9.2	DC Characteristics	23
10.	AC CHARACTERISTICS	24
11.	TOP MARKING SPECIFICATIONS	25
12.	ORDERING INFORMATION	25
13.	PACKAGE DRAWING AND DIMENSIONS	26
14.	REVISION HISTORY	27

新唐科技 NUVOTON
INTELLECTUAL PROPERTY

1. GENERAL DESCRIPTION

W83775G, a two remote and one local temperature sensor with 2 temperature alert outputs and with 2-wire System Management Bus (SMBus™) serial interface, is Nuvoton hardware monitoring IC specifically designed for PC, notebook and any embedded environments. The W83775G uses Ideality factor configuration to eliminate temperature measurement error. The remote temperature sensor input can be connected to thermal diode or transistor such as 2N3904. Because of the two remote temperature sensors, the W83775G can report both temperatures of diodes with Dual-core CPU. A 10-bit plus sign ADC (Analog to Digital Converter) with 0.125°C resolutions is built inside the W83775G to convert the monitored temperature value. Programmable conversion rates and standby mode support low-power operation.

The W83775G is high temperature accuracy, low-power consumption, SMBus™ serial interface IC and is available in 10-pin, TSSOP package. The working voltage is 3.3 V ± 10%.

1.1 Product Selection Guide

Table 1.1 Part Selection

PART NUMBER	SMBUS ADDRESS	FUNCTIONALITY			PACKAGE
		REMOTE	LOCAL	OTHER	
W83775G	1001_100xb	2	1	Programmable temperature High/Low limit	TSSOP-10 (MSOP-10)
W83775G-2	1001_101xb				

2. FEATURES

2.1 Monitoring Items - Temperature

- Measure the temperature with high accuracy
- One on-chip thermal sensor
- Two remote temperature sensor inputs
- Ideality Factor Configuration on External Diodes.
- Remote Diode Fault Detection.

2.2 General

- Interface: SMBus™ serial interface
- 3.3V±10% V_{CC} operation
- 10 bit plus sign remote temperature data format, 0.125°C resolution
- Programmable offset register for various thermal diodes
- SMBus™ 2.0 compatible interface, supports TIMEOUT
- Programmable conversion rates allow user to optimize the power consumption.
- Supply 2 alert output on first remote channel: \overline{ALERT} and $\overline{T_CRIT_A}$
- \overline{ALERT} Output supports SMBus™ 2.0 protocol
- Programmable Temperature High/Low limit and hysteresis for \overline{ALERT} and $\overline{T_CRIT_A}$ output
- Report both temperatures of diodes with Dual-core CPU.

2.3 Applications

- Desktop and Notebook computers, support down to 45nm processes and below. (Please refer to application notice for details)
- Hardware Management
- Servers
- Embedded Applications

3. KEY SPECIFICATIONS

- Local temperature range and accuracy
 - 40°C to +125°C (TA)
 - Typ. $\pm 2^\circ\text{C}$ (20°C~40°C)
 - Max. $\pm 3^\circ\text{C}$ (-40°C~125°C)^{*1}
- Remote temperature range and accuracy
 - 40°C to +127°C (TD)
 - Typ. $\pm 1^\circ\text{C}$ (25°C ~70°C)
 - Typ. $\pm 2^\circ\text{C}$ (-40°C ~127°C)
 - Max. $\pm 3^\circ\text{C}$ (-40°C~127°C)^{*2}
- Supply voltage
- Operating supply current
- Low Power Operation
- ADC resolution include sign bit

3.3V \pm 10%
 900 uA typ.
 15 μ A Standby Current
 10 Bits

*1: Guaranteed by design from -40~125 degree C, 100% tested at 85 degree C.
 *2: Guaranteed by design from -40~127 degree C, 100% tested at 85 degree C.

4. BLOCK DIAGRAM

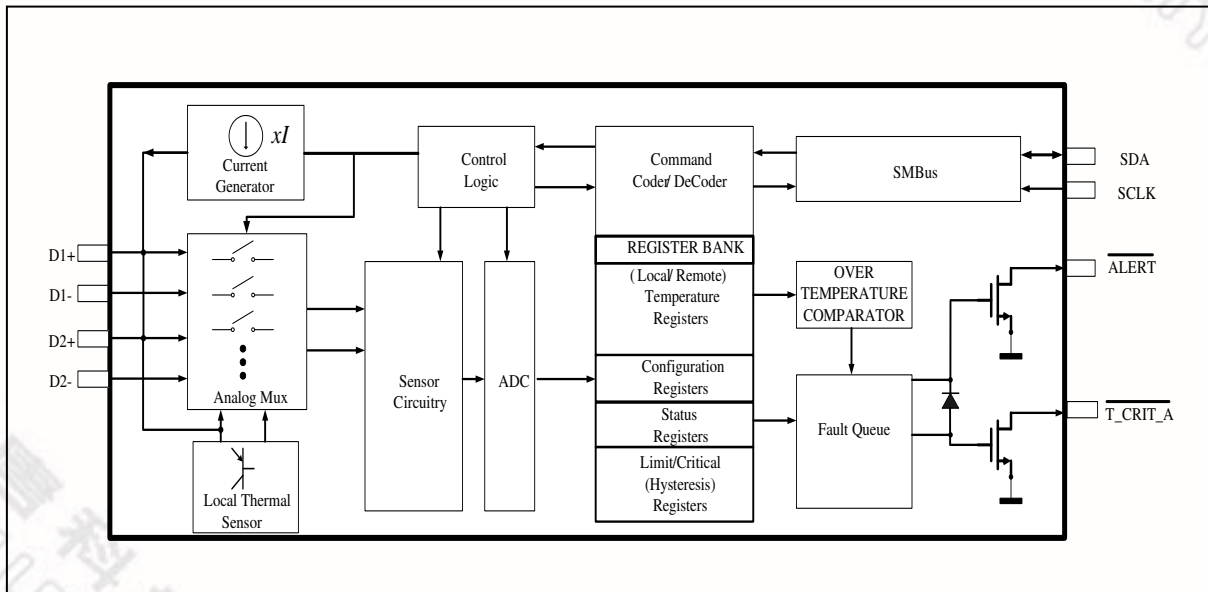

5. PIN CONFIGURATION

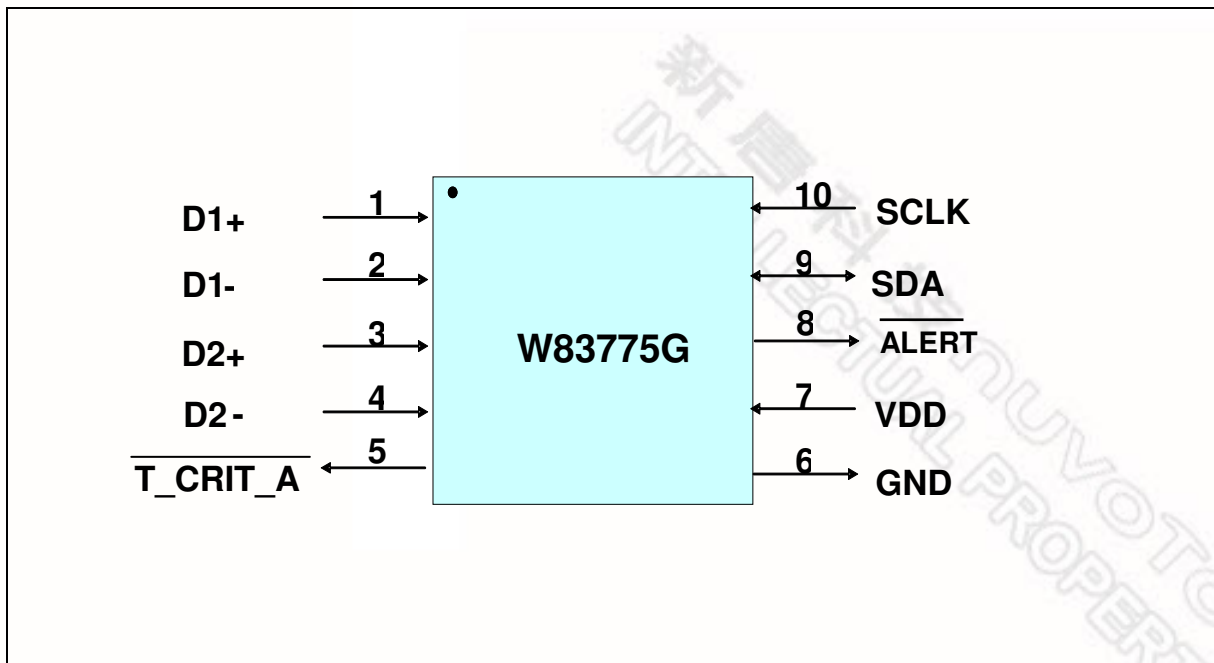

新唐科技 NUVOTON
INTELLECTUAL PROPERTY

6. PIN DESCRIPTION

PIN TYPE	PIN Attribute
I/OD _{12ts}	TTL level and schmitt trigger open drain output with 12 mA sink capability
OD ₁₂	Open-drain output pin with 12 mA sink capability
IN _{ts}	TTL level input pin and schmitt trigger
AIN	Input pin (Analog)

PIN NAME	NO	PIN TYPE	DESCRIPTION
D1+	1	AIN	Connect to Thermal Diode Anode.
D1-	2	AIN	Connect to Thermal Diode Cathode.
D2+	3	AIN	Connect to Thermal Diode Anode.
D2-	4	AIN	Connect to Thermal Diode Cathode.
$\overline{T_CRIT_A}$	5	OD ₁₂	T_CRIT alarm output, for interrupt or shutdown control.
GND	6	GROUND	Power supply ground
VDD	7	POWER	DC power supply, voltage input 3.3V± 10%.
\overline{ALERT}	8	OD ₁₂	Alarm output, for interrupt control.
SDA	9	I/OD _{12ts}	Digital I/O (Open drain). SMBus bidirectional serial data. Requires SMBus pull-up.
SCLK	10	IN _{ts}	Digital Input (Open drain). SMBus serial clock input. Requires SMBus pull-up.

7. FUNCTIONAL DESCRIPTION

7.1 General Description

The W83775G provides two remote temperature sensor inputs which can be connected to remote 2N3904 transistor, or CPU/GPU thermal diode, as well as one local on-die thermal sensor to detect ambient temperature. The W83775G supplies Ideality Factor Configuration on two external diodes to eliminate the temperature measurement error. The W83775G can also report both temperatures of external temperature zones. Selectable conversion rates and modes allow low power operation.

The temperature measured by the W83775G is digitally compared with the value stored in the programmable High/Low limit Registers and T_CRIT registers. Any out-of-limit value can be detected by monitoring Status Register (SR). The W83775G also supports SMBus™ 2.0 ALARM protocol and TIMEOUT.

The data format of the remote temperature is represented by a 10-bit plus sign, two's complement word and 11-bit unsigned binary word with an LSB equal to 0.125°C. The real temperature equals the measured temperature plus or minus offset value. Offset value can be set in offset registers. The data format of the offset registers is also the same as the data format of remote temperature. Local Temperature data is represented by an 8-bit plus sign, two's complement format, with an LSB equal to 1°C.

7.2 Access Interface

The W83775G provides SMBus serial interface to read/write internal registers, and the SMBus address for read and write is 10011001b and 10011000b, respectively.

The W83775G-2 respond to hard-wire SMBus slave address as shown in Table 1.1.

The first serial bus access timing is shown as follows:

(a) Serial bus write to internal address register followed by the data byte

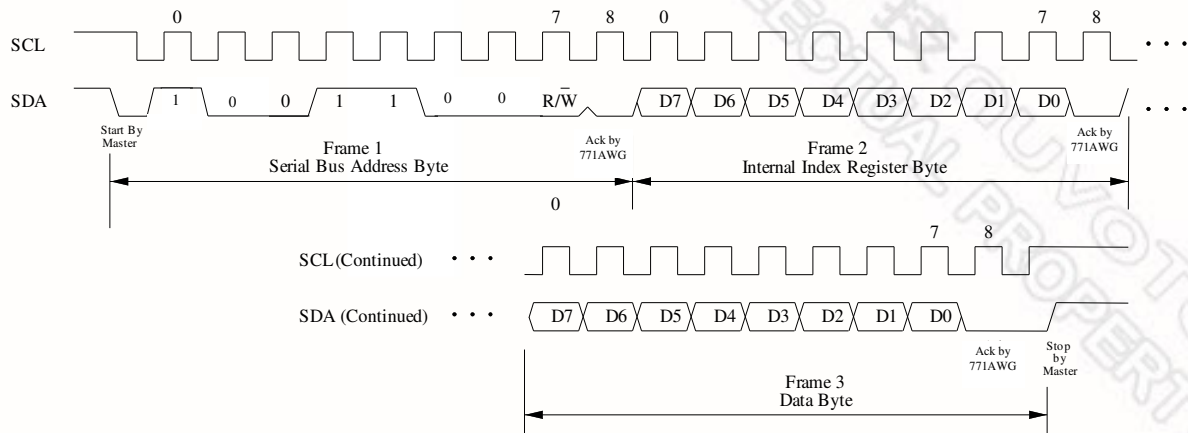

(b) Serial bus read form internal address register followed by the data byte

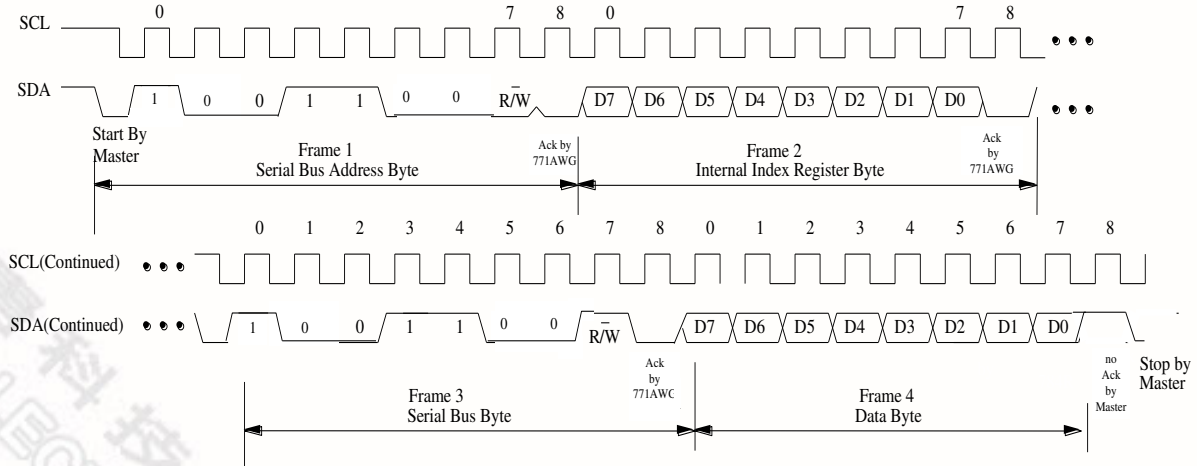

7.3 \overline{ALERT} Output Mode

The W83775G \overline{ALERT} pin is an active-low, open-drain output pin which is triggered when the measured temperature exceeds the limits defined in limit registers. There are three types of \overline{ALERT} output mode: \overline{ALERT} output comparator mode, \overline{ALERT} output interrupt mode, and \overline{ALERT} output SMBus ALERT mode.

7.3.1 \overline{ALERT} Output Comparator Mode

Fig. 7.3.1 shows the mechanism of \overline{ALERT} output comparator mode. Setting Filter and Alert Configure Register, or register address BFh, D0 to 1 enables \overline{ALERT} output comparator mode. In this mode, the \overline{ALERT} pin will be alerted if the monitored temperature is out-of-limit and the \overline{ALERT} pin keeps low until the temperature goes back to the target range. This mode is not power-on default setting.

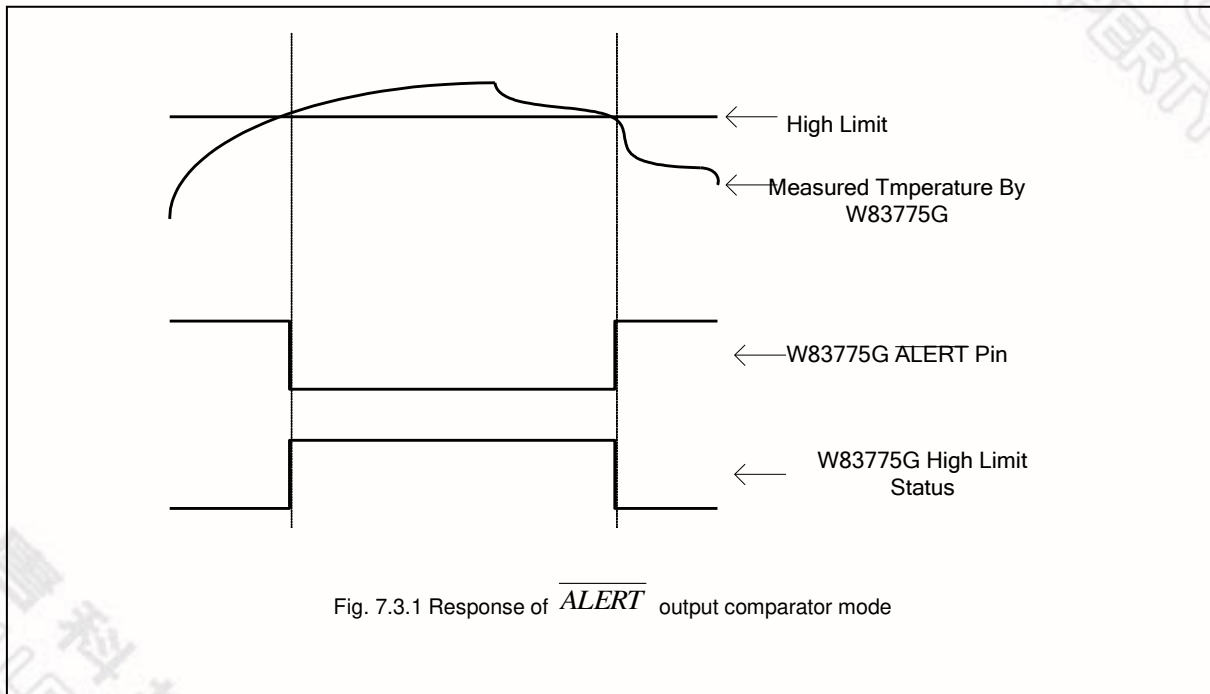
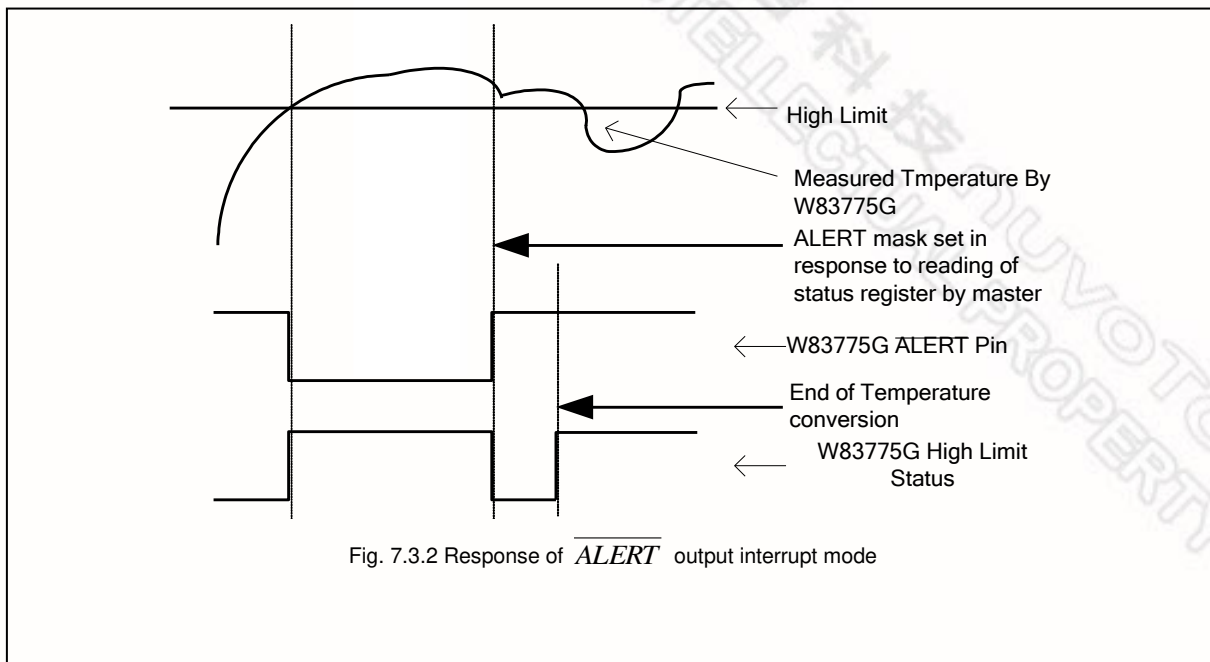

Fig. 7.3.1 Response of \overline{ALERT} output comparator mode

7.3.2 \overline{ALERT} Output Interrupt Mode

Fig. 7.3.2 shows the mechanism of \overline{ALERT} output interrupt mode. In this mode, the W83775G will set the ALERT mask bit D7 of Configuration Register during a read of the Status Register if any flag in

Status Register, except the Busy flag D7 and OPEN flag D2, is set. This prevents further \overline{ALERT} triggering until the master has reset the ALERT mask bit, at the end of the interrupt service routine. The Status Register flags are cleared only upon a read command from the master and will be re-alerted at the end of the next conversation if the measured temperature still falls outside of the allowed range.



新唐科技 NUVOTON
INTELLECTUAL PROPERTY

7.3.3 \overline{ALERT} Output SMBus ALERT Mode

Fig. 7.3.3 shows the mechanism of the \overline{ALERT} output SMBus™ ALERT mode. In this mode, the \overline{ALERT} output of the W83775G is connected to the SMBus™ alert line which has more than one device connected to it. Through such an implementation, SMBus™ ALERT mode can assist the master in resolving which slave generates an interrupt. When the measured temperature falls outside of the allowed range, the \overline{ALERT} pin will be pulled low and the corresponding alert flags in Status Register will be pulled high. The ALERT mask bit will just be set if there is a read command for Status Register or when SMBus™ ALERT Response Address (ARA) occurs from master (Alert Response Address is 0001100). Meanwhile, the W83775G will generate and return its own address to the master. If the temperature never falls outside of the allowed range, the latched \overline{ALERT} pin can be released by the reset ALERT mask bit, and the latched corresponding alert flags in Status Register can be released by reading command for Status Register. Please also refer to the W83L771AWG_773G_775G Application Note 3.pdf for implementation.

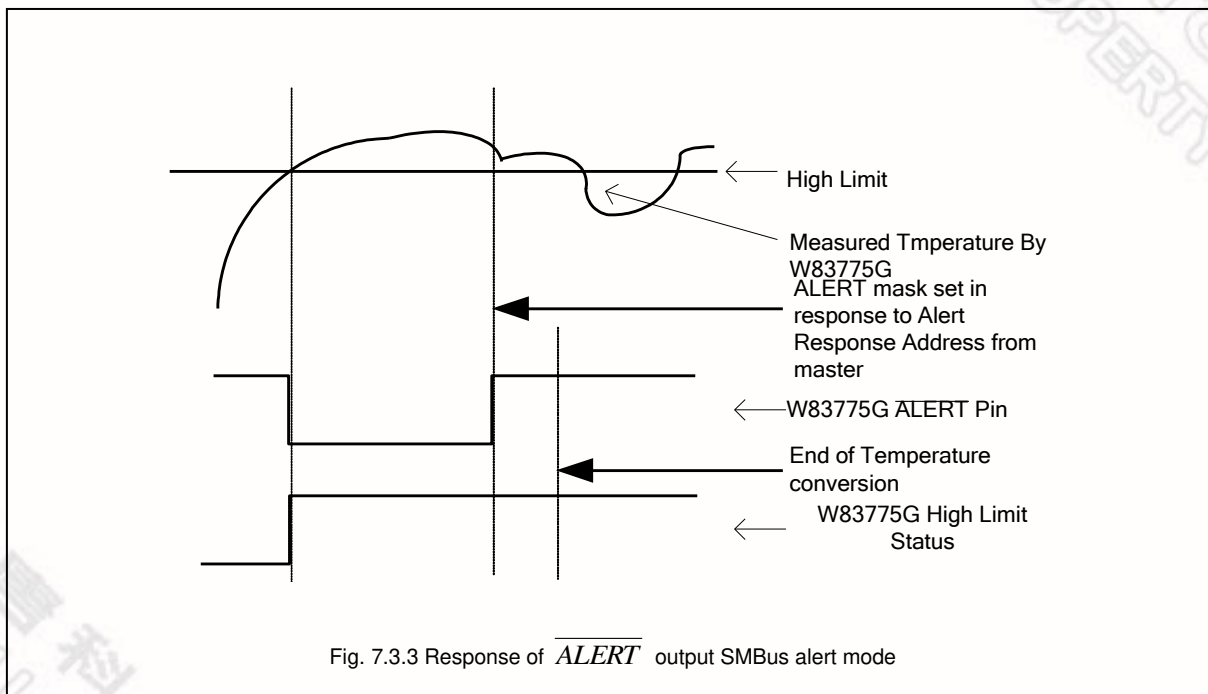

Fig. 7.3.3 Response of \overline{ALERT} output SMBus alert mode

7.4 $\overline{T_CRIT_A}$ Output and T_CRIT flags

$\overline{T_CRIT_A}$ Output pulls low when the measured temperature exceeds the critical temperature (T_CRIT) defined in 19h, 1Ah and 20h for Remote A, Remote B and Local T_CRIT set point, respectively. Once the $\overline{T_CRIT_A}$ Output pulls low, it will not be set high until the measured temperature is lower than (T_CRIT - TH), where TH is Temperature Hysteresis. Status Register will not be reset until it is read and the temperature conversion falls below the T_CRIT set point. Figure 7.4 shows this mechanism. Please also refer to the W83L771AWG_773G_775G Application Note 4.x.pdf for implementation.

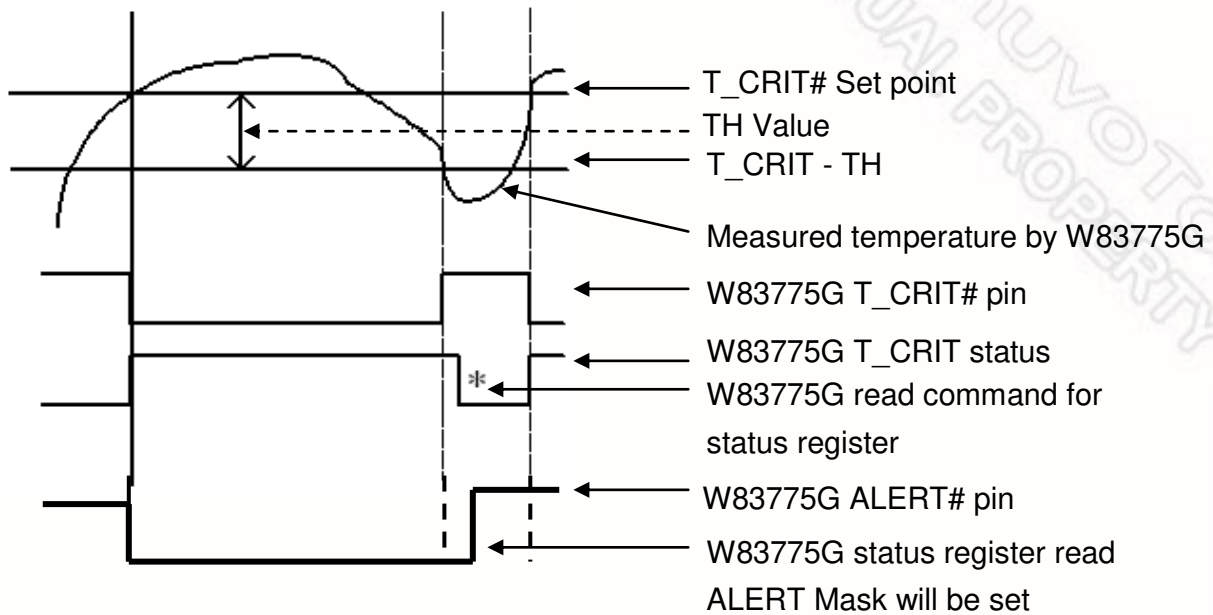

Fig. 7.4 Response of $\overline{T_CRIT_A}$ output

7.5 Measured Temperature Data Format

The W83775G can measure remote temperature with the resolution of 11-bit two's complement format and local temperature with the resolution of 8-bit two's complement format.

7.5.1 Measure Remote Temperature Data Format

Table 7.5.1 shows remote temperature data with 11-bit two's complement format.

Table 7.5.1 Measured Remote Temperature Data Format

TEMPERATURE	8-BIT DIGITAL OUTPUT HIGH BYTE	8-BIT DIGITAL OUTPUT LOW BYTE
+127.875 °C	0111,1111	111X,XXXX
+25.750 °C	0001,1001	110X,XXXX
+2.250 °C	0000,0010	010X,XXXX
+1.125 °C	0000,0001	001X,XXXX
+0.000 °C	0000,0000	000X,XXXX
- 1.125 °C	1111,1110	111X,XXXX
- 2.250 °C	1111,1101	110X,XXXX
- 25.750 °C	1110,0110	010X,XXXX
- 127.875 °C	1000,0000	001X,XXXX

7.5.2 Measure Local Temperature Data Format

Table 7.5.2 shows the local temperature data with 8-bit two's complement format.

Table 7.5.2 Measured Local Temperature Data Format

TEMPERATURE	8-BIT DIGITAL OUTPUT
+127 °C	0111,1111
+25 °C	0001,1001
+2 °C	0000,0010
+1 °C	0000,0001
+0 °C	0000,0000
- 1 °C	1111,1111
- 2 °C	1111,1110
- 25 °C	1110,0111
- 128 °C	1000,0000

7.6 Digital Filter

The W83775G provides three levels Digital Filter to suppress erroneous remote temperature readings due to noise. The register address to set digital filter is in Filter and Alert Configure Register. Setting bits <D2, D1> = <0, 0> selects no filter. Setting bits <D2, D1> = <0, 1> or <1, 0> selects filter level 1. Setting bits <D2, D1> = <1, 1> selects level 2. Figure 7.6.1 shows the step response of reading remote temperature at different filter level, and Figure 7.6.2 shows the impulse response.

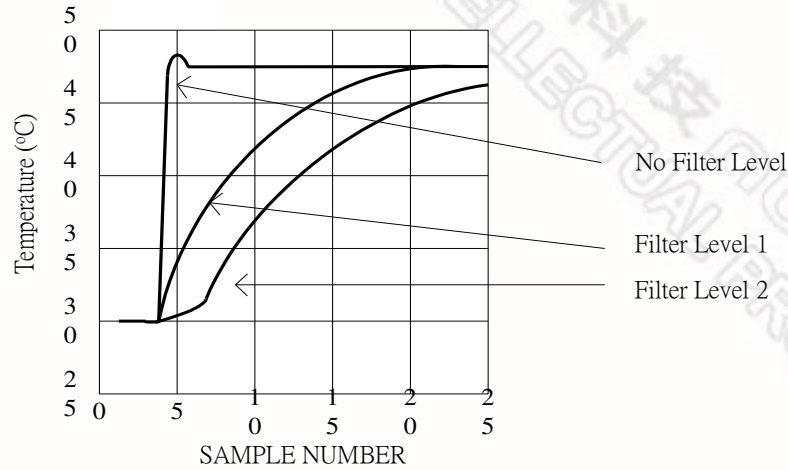

Figure 7.6.1 Step Response of reading remote temperature

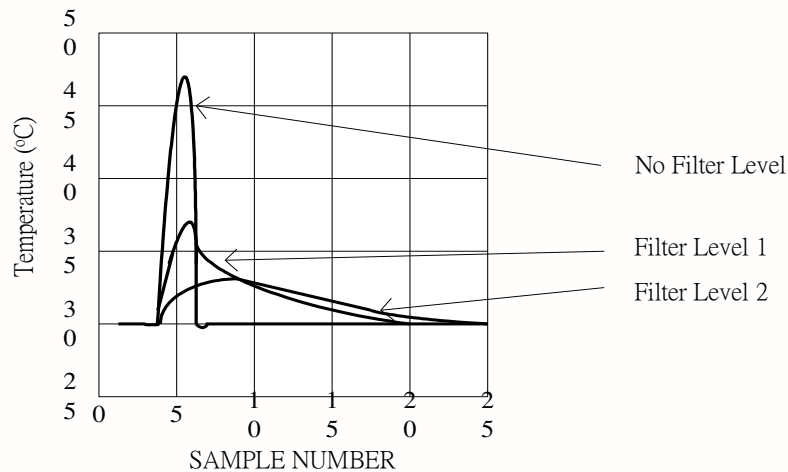

Figure 7.6.2 Impulse Response of reading remote temperature

7.7 Fault Detect

Table 7.7 shows the response of Fault Detection if false connection of D+ and D- occurs after power up. Please also refer to the W83L771AWG_773G_775G Application Note 2.pdf for implementation.

Table 7.7 response of Fault Detect

CONNECTION (D+, D-)	STATUS REGISTER BIT	MEASURED REMOTE TEMPERATURE
(VDD, Floating)	1	+127.875 °C
(GND, Floating)	1	+127.875 °C
(Floating, Floating)	1	+127.875 °C
Short	1	+127.875 °C

7.8 Conversion Rate and Moving Average

The W83775G provides an embedded moving average into conversion rate selection. Each conversion rate can set a couple of proper noise rejection and average supply current.

新唐科技 NUVOTON
INTELLECTUAL PROPERTY

8. CONTROL AND STATUS REGISTER

8.1 W83775G Registers

REGISTER NAME (HEX)	READ ADDRESS (HEX)	WRITE ADDRESS (HEX)	POWER ON DEFAULT STATES	
			<D7:D0> BINARY / HEX	DECIMAL
Local Temperature (LT)	00h	Read Only	0000,0000b / 00h	0
Remote Temperature A High Byte (RTAHB)	01h	Read Only	0000,0000b / 00h	0
Status Register 1 (SR1)	02h	Read Only	0000,0000b / 00h	0
Configuration 1 (C1)	03h	09h	0000,0001b / 01h	1
Conversion Rate (CR)	04h	0Ah	0000,1000b / 08h	8
Local High Set point (LHS)	05h	0Bh	0100,0110b / 46h	70
Local Low Set point (LLS)	06h	0Ch	1101,1011b / DBh	-40
Remote A High Set point High Byte (RAHSHB)	07h	0Dh	0100,0110b / 46h	70
Remote A Low Set point High Byte (RALSHB)	08h	0Eh	1101,1011b / DBh	-40
Remote Temperature A Low Byte (RTALB)	10h	Read Only	0000,0000b / 00h	0
Remote Temperature A Offset High Byte (RTAOHB)	11h	11h	0000,0000b / 00h	0
Remote Temperature A Offset Low Byte (RTAOLB)	12h	12h	0000,0000b / 00h	0
Remote A High Set point Low Byte (RAHSLB)	13h	13h	0000,0000b / 00h	0
Remote A Low Set point Low Byte (RALSLB)	14h	14h	0000,0000b / 00h	0
Remote Temperature B Offset High Byte (RTBOHB)	15h	15h	0000,0000b / 00h	0
Remote Temperature B Offset Low Byte (RTBOLB)	16h	16h	0000,0000b / 00h	0
Status Register 2 (SR2)	17h	Read Only	0000,0000b / 00h	0
Configuration 2 (C2)	18h	18h	0000,0000b / 00h	0
Remote A T_CRIT Set point (RCAS)	19h	19h	0110,1110b / 6Eh	110
Remote B T_CRIT Set point (RCBS)	1Ah	1Ah	0110,1110b / 6Eh	110
Remote B High Set point High Byte (RBHSHB)	1Bh	1Bh	0100,0110b / 46h	70
Remote B Low Set point High Byte (RBLSHB)	1Ch	1Ch	1101,1011b / DBh	-40
Remote B High Set point Low Byte (RBHSLB)	1Dh	1Dh	0000,0000b / 00h	0
Remote B Low Set point Low Byte (RBLSLB)	1Eh	1Eh	0000,0000b / 00h	0
Local T_CRIT Set point (LCS)	20h	20h	0101,0101b / 55h	85
T_CRIT Set point (TH)	21h	21h	0000,1010b / 0Ah	10

REGISTER NAME (HEX)	READ ADDRESS (HEX)	WRITE ADDRESS (HEX)	POWER ON DEFAULT STATES	
			<D7:D0> BINARY / HEX	DECIMAL
Remote Temperature B High Byte (RTBHB)	24h	Read Only	0000,0000b / 00h	0
Remote Temperature B Low Byte (RTBLB)	25h	Read Only	0000,0000b / 00h	0
Remote Diode Temperature Filter (RDTFA, RDTFB)	BFh	BFh	0000,0000b / 00h	0
Remote Diode A ideality (IDEAA)	E3h	E3h	1000,0100b / 84h	132
Remote Diode B ideality (IDEAB)	E4h	E4h	1000,0100b / 84h	132
Remote Temperature B Enable (RTBE) *For W83775G-2 only.	Write only	E8h	0101,0101b / 55h	85
Read Manufacturer's ID (RMID)	FEh	Read Only	0101,1100b / 5Ch	92
Read Die Revision (RDR)	FFh	Read Only	0001,0000b / 10h	16
			0001,0001b / 11h	17
			0001,0011b / 13h	19

新唐科技 NUVOTON
INTELLECTUAL PROPERTY

8.2 Data Format of Temperature Registers

(LT, RTAHB, RTALB, LHS, RAHSHB, RAHSLB, LLS, RALSHB, RALSLB, RTBHB, RTBLB, RBHSHB, RBHSLB, RBLSHB, RBLSLB, RTAOHB, RTAOLB, RTBOHB, RTBOLB, RCAS, RCBS, LCS)

The following table shows the data format, Two's Complement, of the temperature, including Local Temperature (LT), Remote Temperature A High Byte (RTAHB), Remote Temperature A Low Byte (RTALB), Local High Set point (LHS), Remote A High Set point High Byte (RAHSHB), Remote A High Set point Low Byte (RAHSLB), Local Low Set point (LLS), Remote A Low Set point High Byte (RALSHB), Remote A Low Set point Low Byte (RALSLB), Remote Temperature B High Byte (RTBHB), Remote Temperature B Low Byte (RTBLB), Remote B High Set point High Byte (RBHSHB), Remote B High Set point Low Byte (RBHSLB), Remote B Low Set point High Byte (RBLSHB), Remote B Low Set point Low Byte (RBLSLB), Remote Temperature A Offset High Byte (RTAOHB), Remote Temperature A Offset Low Byte (RTAOLB), Remote Temperature B Offset High Byte (RTBOHB), Remote Temperature B Offset Low Byte (RTBOLB), Remote A T_CRIT Set point (RACS), Remote B T_CRIT Set point (RBCS), and Local T_CRIT Set point (LCS),

Only remote temperature, remote high set point, remote low set point, and remote temperature offset support two bytes, up to 0.125°C resolution for the temperature data format; others support one byte, up to 1°C resolution for the temperature data format.

REGISTER OF HIGH BYTE: LT, RTAHB, RTBHB, LHS, RAHSHB, RBHSHB, LLS, RALSHB, RBLSHB, RTAOHB, RTBOHB, CAS, RCBS, LCS								
DATA FORMAT: TWO'S COMPLEMENT FORMAT								
BIT	D7	D6	D5	D4	D3	D2	D1	D0
VALUE	Sign	64	32	16	8	4	2	1
Unit: °C								
REGISTER OF LOW BYTE: RTALB, RTBLB, RAHSLB, RBHSLB, RALSLB, RBLSLB, RTAOLB, RTBOLB								
DATA FORMAT: TWO'S COMPLEMENT FORMAT								
BIT	D7	D6	D5	D4	D3	D2	D1	D0
VALUE	0.5	0.25	0.125	0	0	0	0	0

8.3 Status Register (SR1)

Read Address: 02h

Write Address: Read Only

Power On Default States: 00h

BIT	FLAG NAME	DESCRIPTION
D7	Busy	Setting to '1' indicates ADC is busy converting.
D6	LHIGH	Setting to '1' indicates a measured Local Temperature Higher than Local High set point (High Limit).
D5	LLOW	Setting to '1' indicates a measured Local Temperature lower than Local Low set point (Low Limit).
D4	RAHIGH	Setting to '1' indicates a measured Remote Temperature A higher than Remote High set point (High Limit).
D3	RALOW	Setting to '1' indicates a measured Remote Temperature A lower than Remote Low set point (Low Limit).
D2	OPENA	Setting to '1' indicates a Remote Diode 1 disconnect.
D1	RACRIT	Setting to '1' indicates a Remote A Critical Temperature alarm.
D0	LCRIT	Setting to '1' indicates a Local Critical Temperature alarm.

8.4 Status Register 2 (SR2)

Read Address: 17h

Write Address: Read Only

Power On Default States: 00h

BIT	FLAG NAME	DESCRIPTION
D7	Reserve	
D6	Reserve	
D5	Reserve	
D4	RBHIGH	Setting to '1' indicates a measured Remote Temperature B is higher than Remote High set point (High Limit).
D3	RBLOW	Setting to '1' indicates a measured Remote Temperature B is lower than Remote Low set point (Low Limit).
D2	OPENB	Setting to '1' indicates a Remote Diode B is disconnected.
D1	RBCRIT	Setting to '1' indicates a Remote A Critical Temperature alarm.
D0	Reserve	

8.5 Configuration Register (C1)

Read Address: 03h

Write Address: 09h

Power On Default States: 01h

BIT	FLAG NAME	DESCRIPTION
D7	\overline{ALERT} mask	If this bit is set to '1' \overline{ALERT} interrupts are masked.
D6	STOP/ \overline{RUN}	If this bit is set to '1', Device is into standby mode.
D5	0	No definition and this bit can be read as 0.
D4	Remote A $\overline{T_CRIT_A}$ mask	If this bit is set to '1' Remote A $\overline{T_CRIT_A}$ interrupts are masked.
D3	0	No definition and this bit can be read as 0.
D2	Local $\overline{T_CRIT_A}$ mask	If this bit is set to '1' Local $\overline{T_CRIT_A}$ interrupts are masked.
D1	0	No definition and this bit can be read as 0.
D0	Reserved	Reserved

8.6 Configuration Register 2 (C2)

Read Address: 18h

Write Address: 18h

Power On Default States: 00h

BIT	FLAG NAME	DESCRIPTION
D7	Reserved	
D6	Reserved	
D5	Reserved	
D4	Remote B $\overline{T_CRIT_A}$ mask	If this bit is set to '1' Remote B $\overline{T_CRIT_A}$ interrupts are masked.
D3	Reserved	
D2	Reserved	
D1	Reserved	
D0	Reserved	

8.7 T_CRIT Hysteresis Register (TH)

Read Address: 21h

Write Address: 21h

Power On Default States: 0Ah

REGISTER: TH (MAX. VALUE: 31)								
BIT	D7	D6	D5	D4	D3	D2	D1	D0
VALUE	0	0	0	16	8	4	2	1
Unit: °C								

8.8 Conversion Rate Register (CR)

Read Address: 04h

Write Address: 0Ah

Power On Default States: 08h

REGISTER: CR (DEFAULT CONVERSION RATE: 16HZ)						
(OPENA, OPENB)	(01,10)		00		11	
Temp. sensor	1 local + 1remote(A or B)		2 remote + 1 local		1 local	
BIT<D7:D0>	Frequency/Time(Sec)	Average I _{VDD}	Frequency/Time(Sec)	Average I _{VDD}	Frequency/Time(Sec)	Average I _{VDD}
00h	0.0625Hz/16	==	0.0625Hz/16	==	0.0625Hz/16	==
01h	0.125Hz/8	==	0.125Hz/8	==	0.125Hz/8	==
02h	0.25Hz/4	==	0.25Hz/4	==	0.25Hz/4	==
03h	0.5Hz/2	211uA	0.5Hz/2	211uA	0.5Hz/2	211uA
04h	1Hz/1	232uA	1Hz/1	232uA	1Hz/1	232uA
05h	2Hz/0.5	331uA	2Hz/0.5	331uA	2Hz/0.5	331uA
06h	4Hz/0.25	393uA	4Hz/0.25	393uA	4Hz/0.25	393uA
07h	8Hz/0.125	589uA	8Hz/0.125	589uA	8Hz/0.125	589uA
08h	16Hz/0.0625	833uA	16Hz/0.0625	833uA	16Hz/0.0625	833uA
09h-FFh	Reserve		Reserve		Reserve	

新唐科技 NUVOTON
INTELLECTUAL PROPERTY

8.9 Filter and Alert Configure Register (RDTFA, RDTFB)

Read Address: BFh

Write Address: BFh

Power On Default States: 00h

BIT	COMMAND	DESCRIPTION
<D7:D5>	0	No definition and can be read out to 0.
<D4:D3>	RDTFB Filter Level	<D4, D3>=<0, 0>: No Filter Selected <D4, D3>=<0, 1> or <1, 0>: Filter Level 1 Selected <D4, D3>=<1, 1>: Filter Level 2 Selected
<D2:D1>	RDTFA Filter Level	<D2, D1>=<0, 0>: No Filter Selected <D2, D1>=<0, 1> or <1, 0>: Filter Level 1 Selected <D2, D1>=<1, 1>: Filter Level 2 Selected
D0	\overline{ALERT} Configure	If set to '1' \overline{ALERT} Output Comparator mode is enabled.

8.10 Ideality (IDEAA, IDEAB)

The Ideality factor is dependant upon the process that was used in the fabrication of the particular diode.

Read Address: E3h (IDEAA) and E4h (IDEAB)

Write Address: E3h (IDEAA) and E4h (IDEAB)

Power On Default States: 84h

REGISTER: IDEA (DEFAULT IDEALITY: 1.003)	
BIT<D7:D0>	RANGE
86h	0.9851~0.9924
85h	0.9925~1.0000
84h	1.0001~1.0076
83h	1.0077~1.0153
82h	1.0154~1.0232
81h	1.0233~1.0312
80h	1.0313~1.0393
7Fh	1.0394~1.0476
7Eh	1.0477~1.0560
7Dh	1.0561~1.0645
7Ch	1.0646~1.0731
7Bh	1.0732~1.0819
00h-7Ah, 87h-FFh	Reserved

8.11 Remote Temperature B Enable (RTBE) *for W83775G-2 only.

The remote temperature B channel of **W83775G-2** is default disabled, it is used to make the design convenience for dual core CPU and single core CPU optional on a platform.

Write **0Eh** into **CR[E8h]** to **enable** the Remote Temperature B channel.

Write **0Fh** into **CR[E8h]** to **disable** the Remote Temperature B channel.