



Chipsmall Limited consists of a professional team with an average of over 10 year of expertise in the distribution of electronic components. Based in Hongkong, we have already established firm and mutual-benefit business relationships with customers from,Europe,America and south Asia,supplying obsolete and hard-to-find components to meet their specific needs.

With the principle of “Quality Parts,Customers Priority,Honest Operation,and Considerate Service”,our business mainly focus on the distribution of electronic components. Line cards we deal with include Microchip,ALPS,ROHM,Xilinx,Pulse,ON,Everlight and Freescale. Main products comprise IC,Modules,Potentiometer,IC Socket,Relay,Connector.Our parts cover such applications as commercial,industrial, and automotives areas.

We are looking forward to setting up business relationship with you and hope to provide you with the best service and solution. Let us make a better world for our industry!



## Contact us

Tel: +86-755-8981 8866 Fax: +86-755-8427 6832

Email & Skype: info@chipsmall.com Web: www.chipsmall.com

Address: A1208, Overseas Decoration Building, #122 Zhenhua RD., Futian, Shenzhen, China



THIS COPY IS PROVIDED ON A RESTRICTED BASIS AND IS NOT TO BE USED IN ANY WAY DETRIMENTAL TO THE INTERESTS OF PANDUIT CORP.

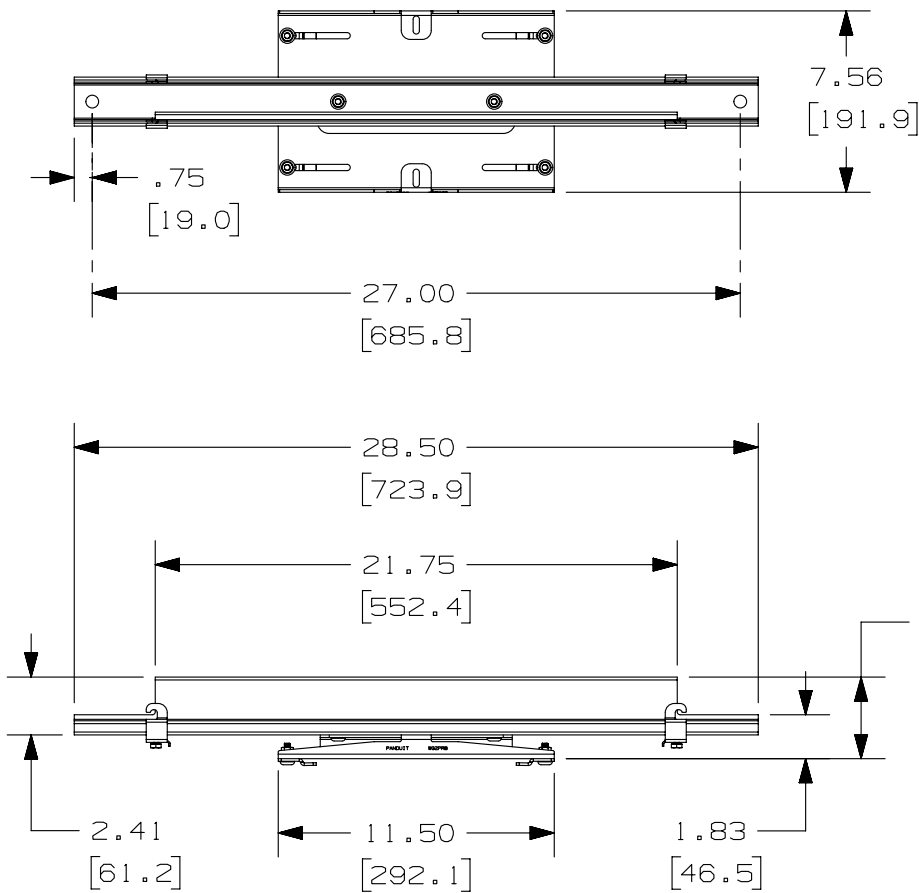

PANDUIT PART NUMBER	WEIGHT
WG2PRB24**	6.02 LB/ EACH (2730.6g/ EACH)

NOTES:

- SEE CURRENT CATALOG FOR ADDITIONAL PART SUFFIXES TO INDICATE PACKAGE QUANTITY.
- THE WYR-GRID RACK MOUNT BRACKET FOR 24" WIDE PATHWAY INCLUDES:  
 ONE (1) 24" WYR-GRID TRAPEZE BRACKET ASSEMBLY.  
 ONE (1) WYR-GRID RACK MOUNT BRACKET BASE ASSEMBLY.  
 TWO (2) 1/4-20 X .75" ROUND HEAD SQUARE NECK BOLT  
 TWO (2) 1/4" SAE FLAT WASHER  
 TWO (2) 1/4" HELICAL SPRING LOCKWASHER  
 TWO (2) 1/4-20 HEX NUT
- DIMENSIONS IN PARENTHESIS ARE IN METRIC.

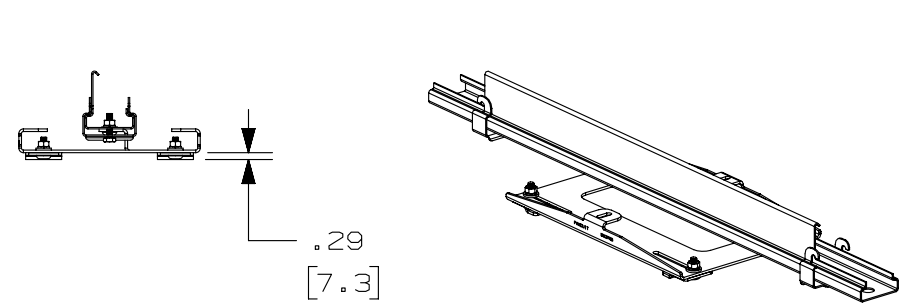

REV	DATE	BY	CHK	APR	DESCRIPTION	ECN
1	07-02-13	SSP	DWR	RN	RELEASED TO PRODUCTION	11D221AS-DC
R	05-03-13	SSP	DWR		DRAWING RELEASED	

TITLE		WYR-GRID RACK MOUNT BRACKET FOR 24" WIDE PATHWAY (WG2PRB24**)	
CUSTOMER DRAWING			
ITEM REVISION NAME		11D221AS/01	
DATASET FILE NAME		11D221AS_DS/01B WG2PRB24**	
UNLESS OTHERWISE SPECIFIED, DIMENSIONAL TOLERANCES ARE: IN ( mm )		MATERIAL: <b>STEEL</b>	
.X ± .XX ± .03 [ .78 ]		.XXX ± ANGLES ± 5 °	
THIRD ANGLE PROJECTION		DRAWING NUMBER: 11D221AS-DC	
DRAWN BY	DATE	CHK	SCALE
SSP	05-03-13	DWR	NONE
SHT 1 OF 1			SIZE A