



Chipsmall Limited consists of a professional team with an average of over 10 year of expertise in the distribution of electronic components. Based in Hongkong, we have already established firm and mutual-benefit business relationships with customers from,Europe,America and south Asia,supplying obsolete and hard-to-find components to meet their specific needs.

With the principle of “Quality Parts,Customers Priority,Honest Operation,and Considerate Service”,our business mainly focus on the distribution of electronic components. Line cards we deal with include Microchip,ALPS,ROHM,Xilinx,Pulse,ON,Everlight and Freescale. Main products comprise IC,Modules,Potentiometer,IC Socket,Relay,Connector.Our parts cover such applications as commercial,industrial, and automotives areas.

We are looking forward to setting up business relationship with you and hope to provide you with the best service and solution. Let us make a better world for our industry!



Contact us

Tel: +86-755-8981 8866 Fax: +86-755-8427 6832

Email & Skype: info@chipsmall.com Web: www.chipsmall.com

Address: A1208, Overseas Decoration Building, #122 Zhenhua RD., Futian, Shenzhen, China



WIZ810MJ Datasheet

(Ver. 1.3)



©2013 WIZnet Co., Ltd. All Rights Reserved.

For more information, visit our website at www.wiznet.co.kr

Document History Information

Revision	Date	Description
Ver. 1.0	September , 2007	Release with WIZ810MJ Launching
Ver. 1.1	February, 2008	Hardware revision(ver.1.1). Modified the SPI_EN signal description (P.8) Modified the Schematic & Partlist : R10 is mounted as SPI_EN pull-down resistor. (P.15~16)
Ver. 1.2	January, 2009	Added temperature specification
Ver. 1.3	January, 2013	Hardware revision(ver.1.2) Changed operation temperature range(P.5) Changed Partlist and schematic

WIZnet's Online Technical Support

If you have something to ask about WIZnet Products, Write down your question on Q&A Board in WIZnet website (www.wiznet.co.kr). WIZnet Engineer will give an answer as soon as possible.

Table of Contents

1.	Introduction	5
1.1.	Features	5
1.2.	Block Diagram	5
2.	Pin Assignments & descriptions	6
2.1.	Pin Assignments	6
2.2.	Power & Ground	6
2.3.	MCU Interfaces.....	7
2.4.	Network status & LEDs	8
2.5.	Miscellaneous Signals	8
3.	Timing Diagrams	9
3.1.	Reset Timing	9
3.2.	Register/Memory READ Timing	10
3.3.	Register/Memory WRITE Timing	11
3.4.	SPI Timing.....	12
4.	Dimensions.....	13
5.	Connector Specification	14
6.	Schematic	15
7.	Partlists.....	16

1. Introduction

WIZ810MJ is the network module that includes W5100 (TCP/IP hardwired chip, include PHY), MAG-JACK (RJ45 with X'FMR) with other glue logics. It can be used as a component and no effort is required to interface W5100 and Transformer. The WIZ810MJ is an ideal option for users who want to develop their Internet enabling systems rapidly.

For the detailed information on implementation of Hardware TCP/IP, refer to the W5100 Datasheet.

WIZ810MJ consists of W5100 and MAG-JACK.

- TCP/IP, MAC protocol layer: W5100
- Physical layer: Included in W5100
- Connector: MAG-JACK(RJ45 with Transformer)

5

1.1. Features

- Supports 10/100 Base TX
- Supports half/full duplex operation
- Supports auto-negotiation and auto crossover detection
- IEEE 802.3/802.3u Complaints
- Operates 3.3V with 5V I/O signal tolerance
- Supports network status indicator LEDs
- Includes Hardware Internet protocols: TCP, IP Ver.4, UDP, ICMP, ARP, PPPoE, IGMP
- Includes Hardware Ethernet protocols: DLC, MAC
- Supports 4 independent connections simultaneously
- Supports MCU bus Interface and SPI Interface
- Supports Direct/Indirect mode bus access
- Supports Socket API for easy application programming
- Interfaces with Two 2.0mm pitch 2 * 14 header pin
- Temperature :

[PCB rev1.0] : 0 ~ 70°C (Operation), -40 ~ 85°C (Storage)

[PCB rev1.1] : 0 ~ 70°C (Operation), -40 ~ 85°C (Storage)

[PCB rev1.2] : -40 ~ 85°C (Operation), -40 ~ 85°C (Storage)

1.2. Block Diagram

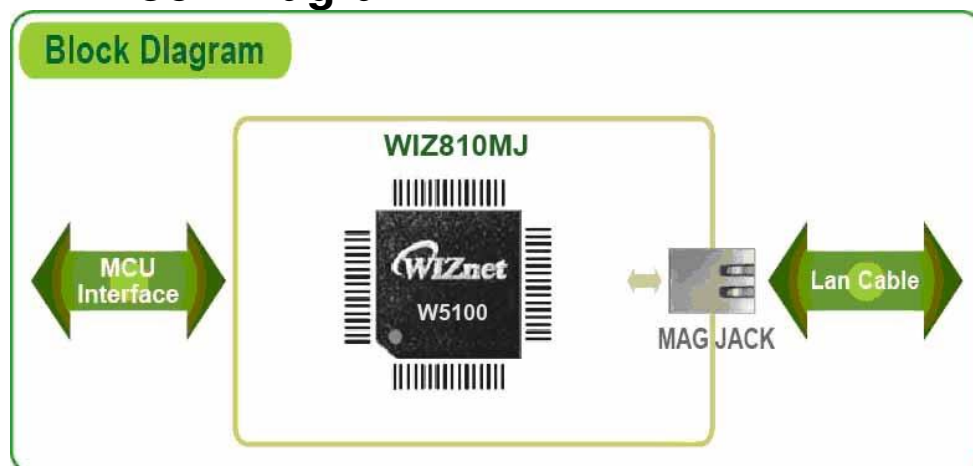

2. Pin Assignments & descriptions

2.1. Pin Assignments

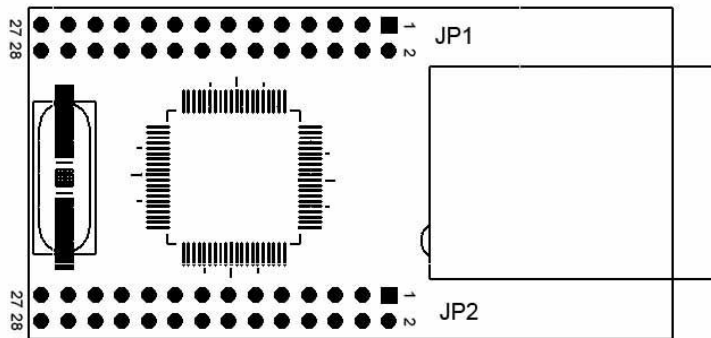

6

JP1				JP2			
VCC	1	2	/INT	GND	1	2	/RESET
/WR	3	4	/RD	NC	3	4	GND
/CS	5	6	NC	NC	5	6	COL_LED
A14_SCLK	7	8	GND	GND	7	8	TX_LED
A12_MOSI	9	10	A13/_SCS	SPI_EN	9	10	RX_LED
A10	11	12	A11_MISO	FDX_LED	11	12	LINK_LED
GND	13	14	A9	GND	13	14	GND
A8	15	16	A7	D1	15	16	D0
A6	17	18	A5	D3	17	18	D2
A4	19	20	A3	D5	19	20	D4
A2	21	22	A1	D7	21	22	D6
A0	23	24	GND	GND	23	24	VCC
NC	25	26	NC	NC	25	26	NC
NC	27	28	NC	NC	27	28	NC

I : Input
I/O : Bi-directional Input and output

O : Output
P : Power

2.2. Power & Ground

Symbol	Type	Pin No.	Description
VCC	P	JP1:1 , JP2:24	Power : 3.3 V power supply
GND	P	JP1:8, JP1:13, JP1:24, JP2:1, JP2:4, JP2:7 JP2:13, JP2:14, JP2:23	Ground

2.3. MCU Interfaces

Symbol	Type	Pin No.	Description
A14_SCLK	I	JP1:7	ADDRESS PIN OR SCLK(Serial Clock) This pin is used to select a register or memory. When asserting SPI_EN pin high, this pin is used to SPI Clock signal Pin.
A13_/SCS	I	JP1:10	ADDRESS PIN or /SCS (Slave Select) * This pin is used to select a register or memory. When asserting SPI_EN pin high, this pin is used to SPI Slave Select signal Pin. In only SPI Mode, this pin is active low
A12_MOSI	I	JP1:9	ADDRESS PIN or MOSI (Master Out Slave In) * This pin is used to select a register or memory. When asserting SPI_EN pin high, this pin is used to SPI MOSI signal pin.
A11_MISO	I/O	JP1:12	ADDRESS PIN or MISO (Master In Slave Out) * This pin is used to select a register or memory. When asserting SPI_EN pin high, this pin is used to SPI MISO signal pin.
A10~A8	I	JP1:11, JP1:14 JP1:15	Address Used as Address[10-8] pin
A7~A0	I	JP1:16 ~ JP1:23	Address Used as Address[7-0] pin
D7~D0	I/O	JP2:21, JP2:22 JP2:19, JP2:20 JP2:17, JP2:18 JP2:15, JP2:16	Data 8 bit-wide data bus
/CS	I	JP1:5	Module Select : Active low. /CS of W5100
/RD	I	JP1:4	Read Enable : Active low. /RD of W5100
/WR	I	JP1:3	Write Enable : Active low /WR of W5100

/INT	O	JP1:2	Interrupt : Active low After reception or transmission it indicates that the W5100 requires MCU attention. By writing values to the Interrupt Status Register of W5100 the interrupt will be cleared. All interrupts can be masked by writing values to the IMR of W5100 (Interrupt Mask Register). For more details refer to the W5100 Datasheet
------	---	-------	----------------------------------------------------------------------------------------------------------------------------------------------------------------------------------------------------------------------------------------------------------------------------------------------------------------------------------------------------------------------

2.4. Network status & LEDs

You can observe the network status using MAG-JACK LEDs. LED interface can be extended to the LED of the main board.

Symbol	Type	Pin No.	Description
COL_LED	O	JP2:6	Collision LED : Active low when collisions occur.
TX_LED	O	JP2:8	Transmit activity LED : Active low indicates the presence of transmitting activity.
RX_LED	O	JP2:10	Receive activity LED : Active low indicates the presence of receiving activity.
FDX_LED	O	JP2:11	Full Duplex LED : Active low when in full duplex operation. Active high when in half duplex operation.
LINK_LED	O	JP2:12	Link LED : Active low in link state indicates a good status for 10/100M. It is always ON when the link is OK and it flashes while in a TX or RX state.

2.5. Miscellaneous Signals

Symbol	Type	Pin No.	Description
/RESET	I	JP2:2	Reset : This pin is active low input to initialize or re-initialize W5100. By asserting this pin low for at least 2us, all internal registers will be re-initialized to their default states.
SPI_EN	I	JP2:9	SPI Enable : This pin selects Enable/Disable W5100 SPI Mode. Low = SPI Mode Disable High = SPI Mode Enable A pull-down resistor(R10) sets to the default of SPI Mode Disable. H/W ver.1.0 : R10 is not mounted H/W ver.1.1 : R10 is mounted
NC	-	JP1 : 6, 25, 26, 27, 28 JP2 : 3, 5, 25, 26, 27, 28	Not Connect

3. Timing Diagrams

WIZ810MJ provides following interfaces of W5100.

- Direct/Indirect mode bus access
- SPI access

3.1. Reset Timing

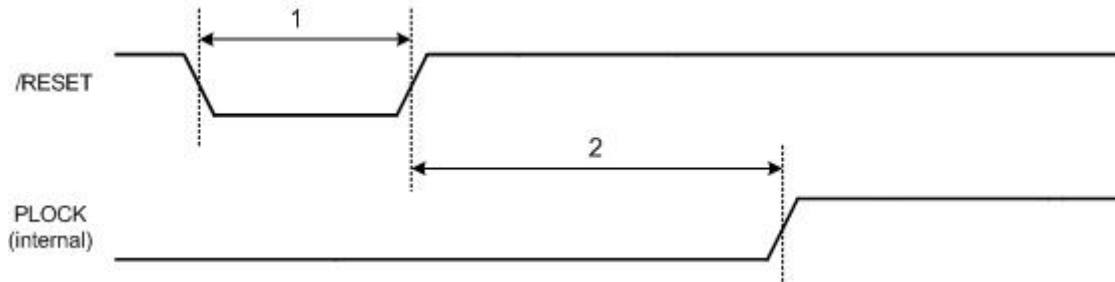

Description		Min	Max
1	Reset Cycle Time	2 us	-
2	/RESET to internal PLOCK	-	10 ms

3.2. Register/Memory READ Timing

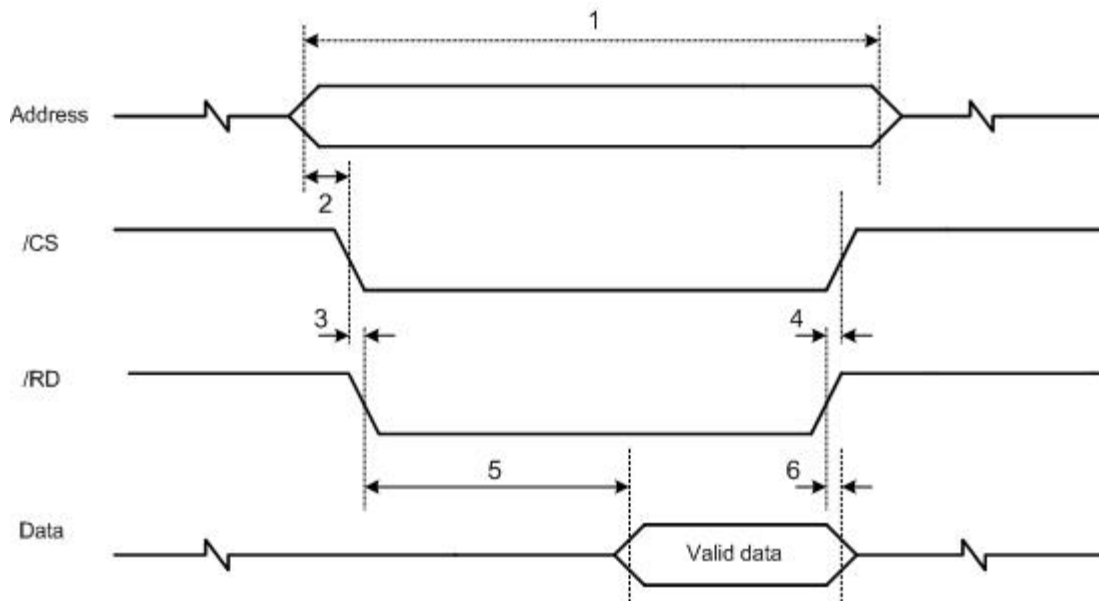

Description		Min	Max
1	Read Cycle Time	80 ns	-
2	Valid Address to /CS low time	8 ns	-
3	/CS low to /RD low time	-	1 ns
4	/RD high to /CS high time	-	1 ns
5	/RD low to Valid Data Output time	-	80 ns
6	/RD high to Data High-Z Output time	-	1 ns

3.3. Register/Memory WRITE Timing

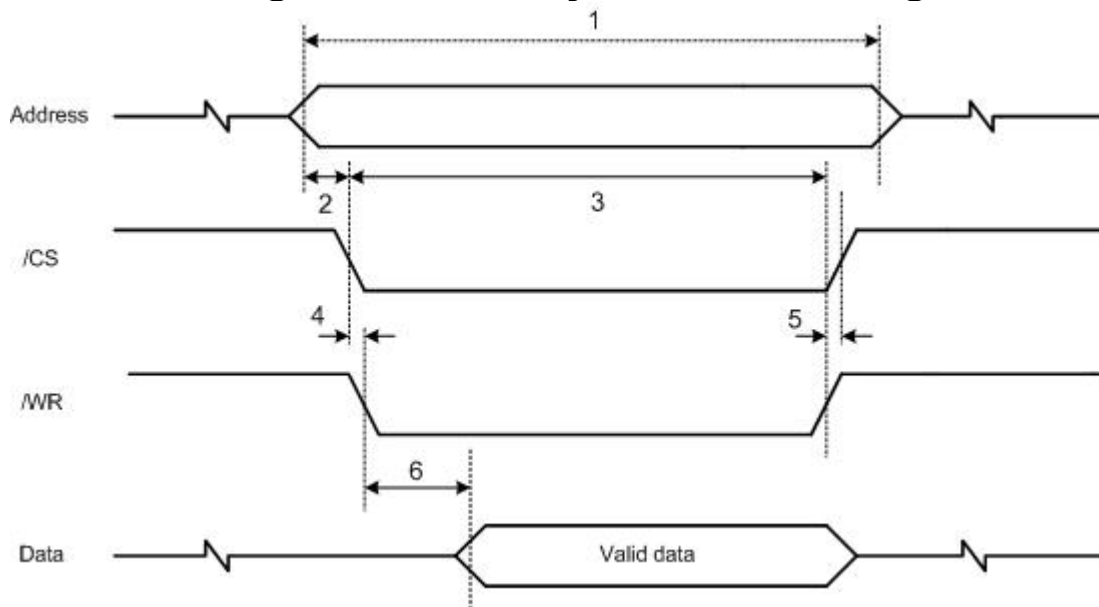

Description		Min	Max
1	Write Cycle Time	70 ns	-
2	Valid Address to /CS low time	7 ns	-
3	/CS low to /WR high time	70 ns	-
4	/CS low to /WR low time	-	1 ns
5	/WR high to /CS high time	-	1 ns
6	/WR low to Valid Data time	-	14 ns

3.4. SPI Timing

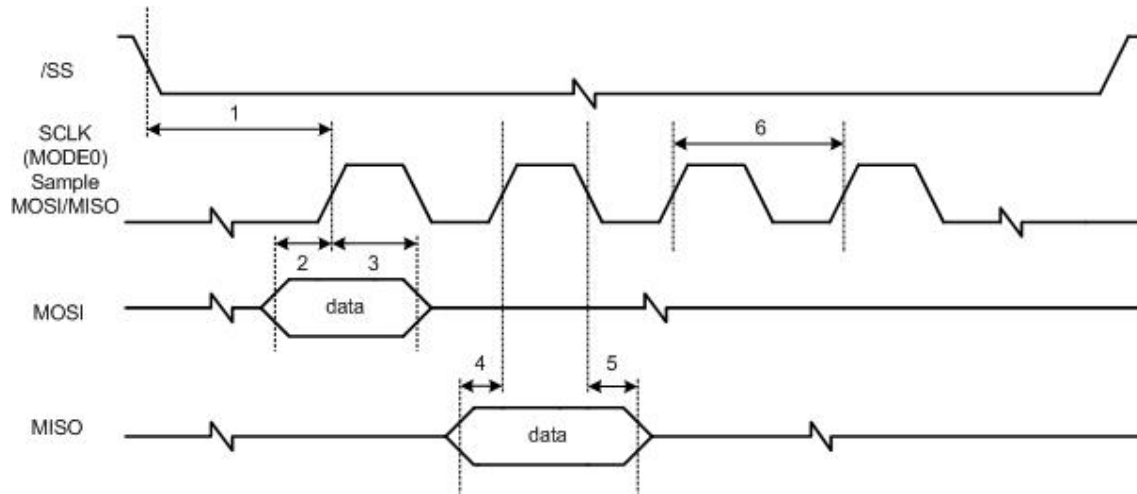

Description	Mode	Min	Max
1 /SS low to SCLK	Slave	21 ns	-
2 Input setup time	Slave	7 ns	-
3 Input hold time	Slave	28 ns	-
4 Output setup time	Slave	7 ns	14 ns
5 Output hold time	Slave	21 ns	-
6 SCLK time	Slave	70 ns	

4. Dimensions

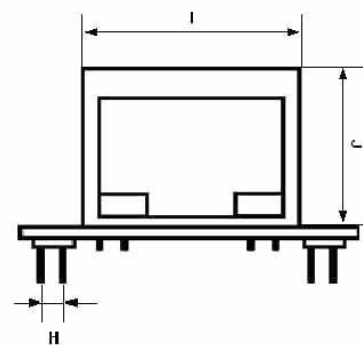
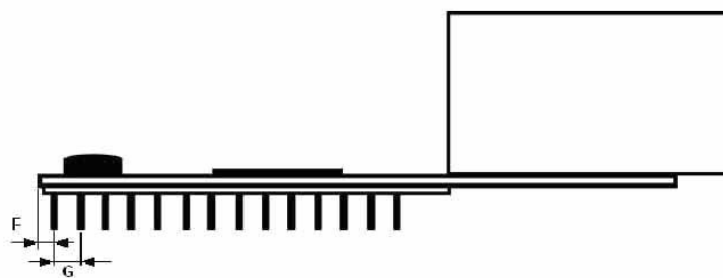
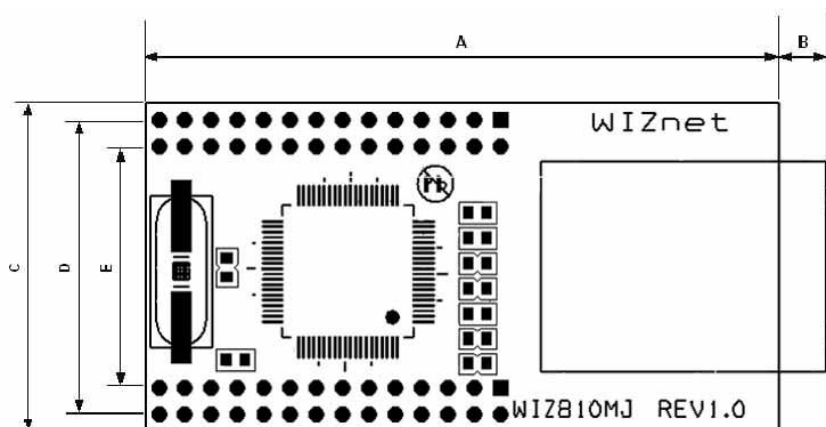

Symbols	Dimensions (mm)
A	48.0
B	3.5
C	25.0
D	22.4
E	18.4
F	1.0
G	2.0
H	2.0
I	16.0
J	13.5

5. Connector Specification

UNIT:mm

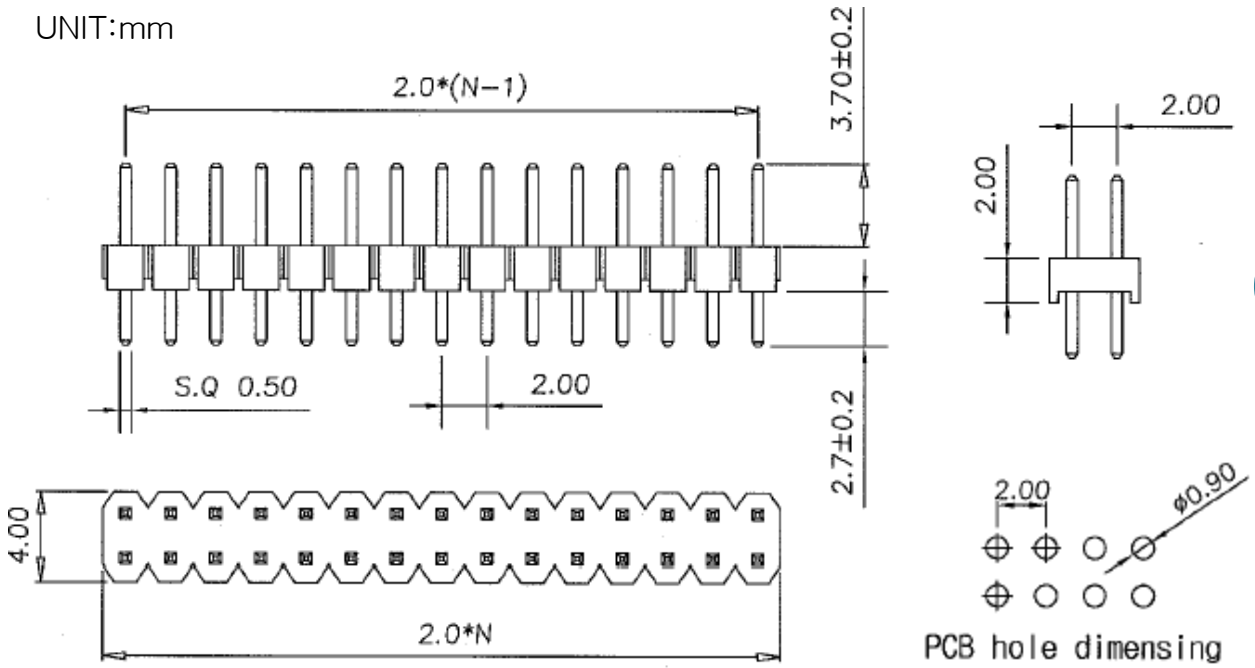

6. Schematic

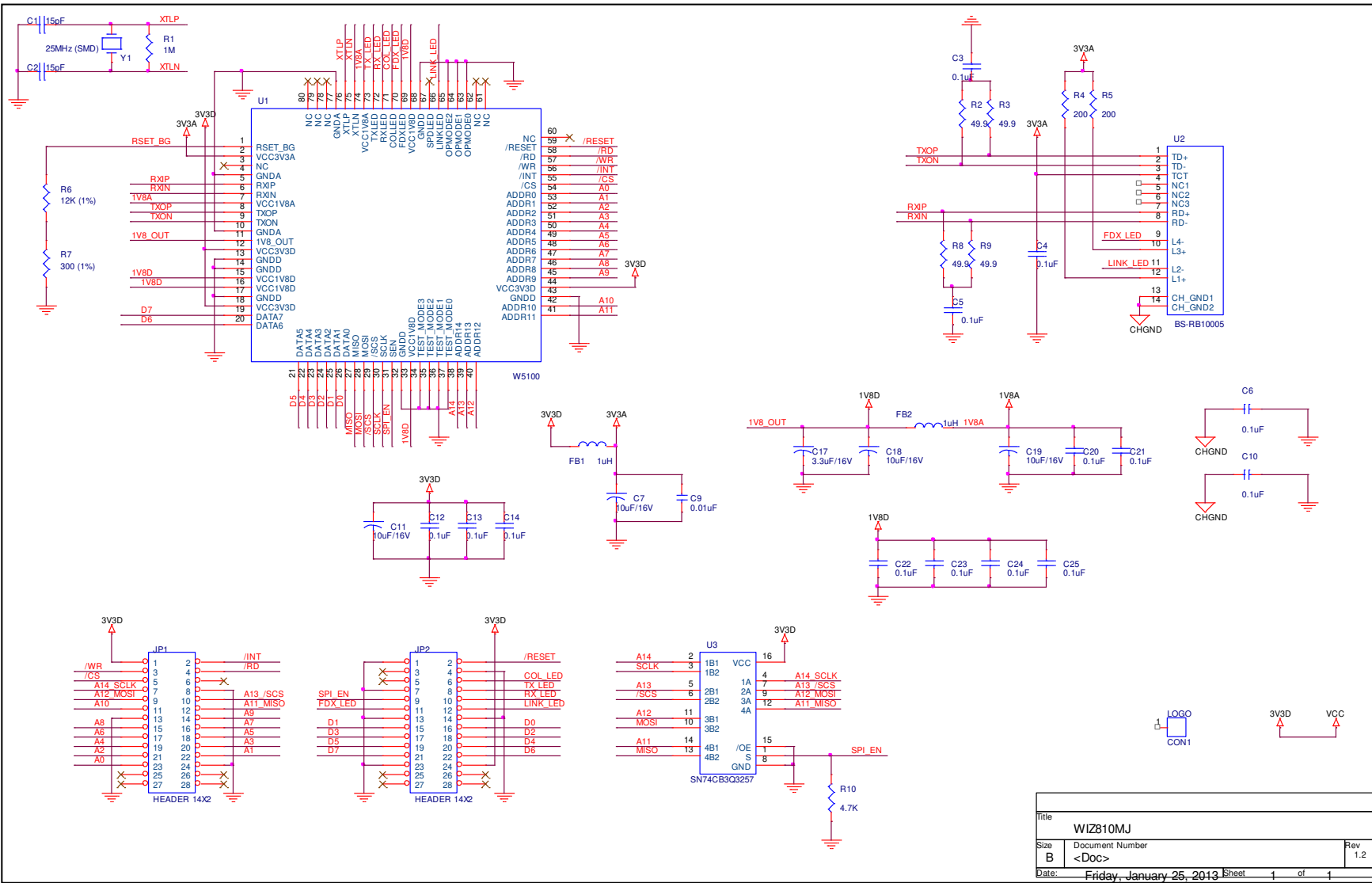

Title		WIZ810MJ	
Size	B	Document Number	<Doc>
Date:	Friday, January 25, 2013	Sheet	1 of 1
			Rev 1.2

7. Partlists

Item	Q.ty	Reference	Part	Tech. Characteristics	Package
1	2	C1,C2	15pF	50V-20% Ceramic	CASE 0603
2	14	C3,C4,C5,C6,C10, C12,C13,C14,C20, C21,C22,C23,C24,C25	0.1uF	50V-20% Ceramic	CASE 0603
3	4	C7,C11,C18,C19	10uF/16V	16Vmin 10%	EIA/IECQ 3216
4	1	C9	0.01uF	50V-20% Ceramic	CASE 0603
5	2	FB1,FB2	1uH Chip Ferrite Inductor		CASE 0805
6	2	JP1,JP2	2X14 28PIN 2mm DIP STRAIGHT Header	2 X 14 2mm pitch	
7	1	R1	1M	1/10W-5% SMD	CASE 0603
8	4	R2,R3,R8,R9	49.9	1/10W-1% SMD	CASE 0603
9	2	R5,R4	200	1/10W-5% SMD	CASE 0603
10	1	R6	12K	1/10W-1% SMD	CASE 0603
11	1	R7	300	1/10W-1% SMD	CASE 0603
12	1	R10	4.7K	1/10W-5% SMD	CASE 0603
13	1	U1	W5100	WIZnet Hardware TCP/IP	LQFP80
14	1	U2	BS-RB10005	Transformer + RJ45	
15	1	U3	SN74CB3Q3257	Bus Switch(vendor : TI)	TSSOP
16	1	Y1	25MHz (SMD)	SMD Type, CL=18pF, Industrial.	SX-1
17	1	PCB	WIZ810MJ REV1.2 1.6T 4LAYER	FR4, OSP	