



Chipsmall Limited consists of a professional team with an average of over 10 year of expertise in the distribution of electronic components. Based in Hongkong, we have already established firm and mutual-benefit business relationships with customers from,Europe,America and south Asia,supplying obsolete and hard-to-find components to meet their specific needs.

With the principle of “Quality Parts,Customers Priority,Honest Operation,and Considerate Service”,our business mainly focus on the distribution of electronic components. Line cards we deal with include Microchip,ALPS,ROHM,Xilinx,Pulse,ON,Everlight and Freescale. Main products comprise IC,Modules,Potentiometer,IC Socket,Relay,Connector.Our parts cover such applications as commercial,industrial, and automotives areas.

We are looking forward to setting up business relationship with you and hope to provide you with the best service and solution. Let us make a better world for our industry!



Contact us

Tel: +86-755-8981 8866 Fax: +86-755-8427 6832

Email & Skype: info@chipsmall.com Web: www.chipsmall.com

Address: A1208, Overseas Decoration Building, #122 Zhenhua RD., Futian, Shenzhen, China



Airborne™ Enterprise Class Ethernet Bridge Module

Ethernet to 802.11b/g

WLNG-ET-DP501

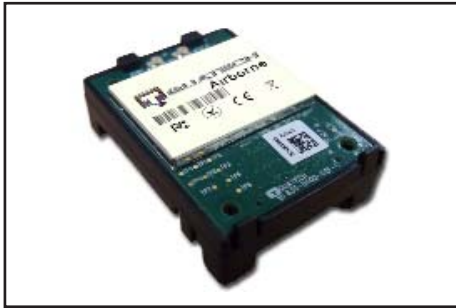

Airborne™ is a line of highly integrated 802.11 radios and device servers, designed to address the demands of complex machine-to-machine (M2M) applications. Utilizing the latest 802.11 microprocessor and network technologies, the Airborne family of products provide a broad encompassing solution for wireless applications requiring performance, reliability and advanced security.

The Airborne Ethernet bridge family allows an Ethernet enabled device to connect to a high performance wireless 802.11 network. The integrated Network Address Translation (NAT) functionality provides plug and play connectivity and simple integration to any system with an Ethernet port. The Ethernet interface supports auto rate detection up to 100Mb/s. The WLNG-ET-DP500 includes a full featured 802.11b/g radio and a high performance ARM9 MCU running embedded Linux.

Enterprise Class Security

WPA2-Enterprise is the leading wireless security standard for enterprise networks and is fully supported by the Airborne Enterprise products. The integrated supplicant supports a wide range of EAP processes including:

- EAP-TLS/MSCHAPv2
- EAP-TLS/MD5
- EAP-TTLS/MSCHAPv2
- PEAPv0/MSCHAPv2
- LEAP

Airborne supports the most flexible certificate delivery and management available in the embedded device market, along with WEP, WPA, WPA2, 802.11i and Pre-shared Key (PSK), no other wireless solution provides a more comprehensive security solution.

Reliability

Designed by Quatech specifically to meet the demands of the industrial, automotive and medical markets, the Airborne device server has the widest operating temperature range and highest level of reliability available, all backed by a five year limited warranty. Quatech also provides FCC Modular certification, minimizing requirements for further regulatory testing by original equipment manufacturers.

Applications

Previous generations of Airborne Ethernet Bridge Modules have been integrated and deployed into a wide range of applications across various industries including:

- Medical equipment
- Vehicle telematics & diagnostics
- Material handling & logistics
- Industrial Automation
- Test & measurement
- Security & access control

Quatech's Airborne Enterprise Ethernet Bridge Module extends the reputation of the family further by drawing on experience of Quatech application engineers across hundreds of wireless M2M deployments. The advanced technologies implemented in the Quatech

KEY FEATURES

- 802.11b/g WiFi Radio with 32bit ARM9 CPU
- Plug-n-Play Ethernet to 802.11 Connectivity
- Enterprise Class wireless security (WPA2-Enterprise, WPA2-PSK, WPA-PSK, WEP, EAP) with Certificates
- Extended Operating Temperature Range (-40°C to +85°C) and environmental specifications
- Advanced Low Power Modes
- Integrated 10/100 Ethernet PHY
- Configurable wireless and wired interfaces
- Removes need for RF, networking and communications expertise
- Quick time to market and reduced integration costs
- Worldwide Certification Support- FCC Part 15 Class B Sub C Modular Approval, IOC, CE, ETSI, ROHS, WEEE
- Upgradable Airborne Device Server Firmware
- 5 year limited warranty

Enterprise 802.11 Ethernet Bridge provide an industry-leading solution with breakthrough performance and security for M2M applications and drop in replacements for existing 802.11b and 802.11b/g networking modules.

Model Selection Guide

Model #	Description	WiFi	Interface			Security				
		802.11b/g	Ethernet	GPIO	WEP	WPA	WPA2	LEAP	EAP	
WLNG-ET-DP501	802.11b/g, 10/100 Ethernet interface	■	■	■	■	■	■	■	■	
<i>To evaluate all available features and receive evaluation tools, order below.</i>										
WLNG-EK-DP503	802.11b/g Enterprise Class Device Server Module Eval Kit, Ethernet to 802.11b/g									

Block Diagram

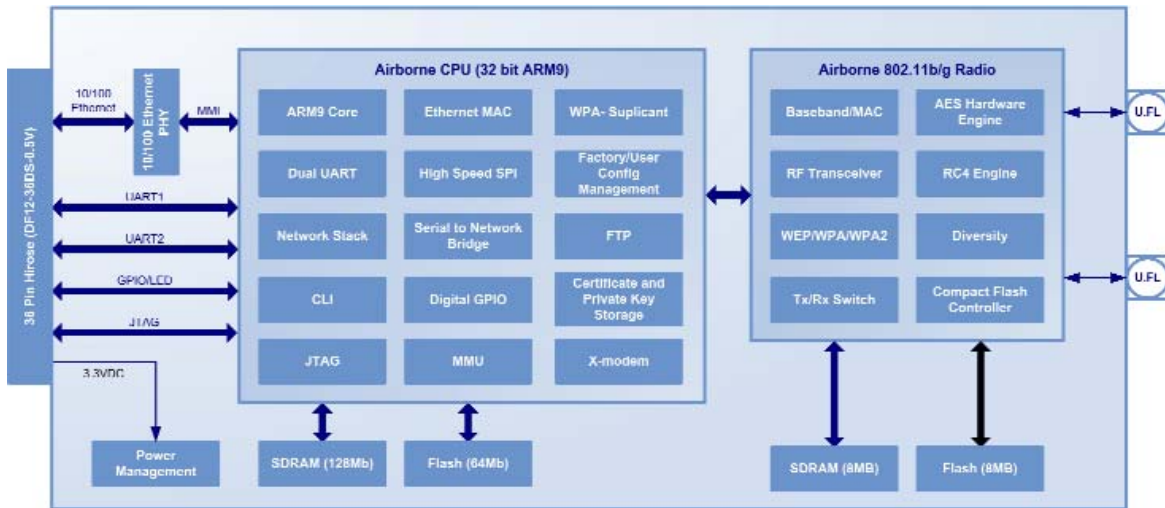

Mechanical Outline

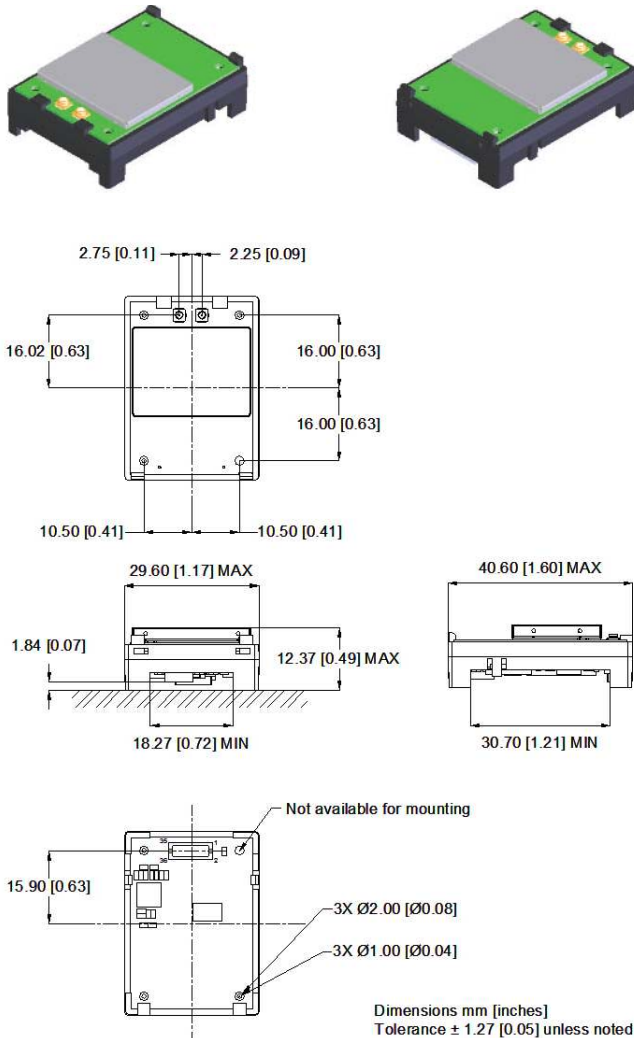

Specifications

Technology	IEEE 802.11b/g, WiFi compliant
Frequency	2.4 ~ 2.4835 GHz (US/Canada/Europe) 2.4 ~ 2.497 GHz (Japan)
Modulation Technology	DSSS, CCK, OFDM
Modulation Type	DBPSK, DQPSK, CCK, BPSK, QPSK, 16QAM, 64QAM
Network Access Modes	Infrastructure, Ad Hoc
Channels	USA/Canada: 11 channels Europe: 13 channels France: 4 channels Japan: 14 channels (13 channels for 802.11g)
Wireless Data Rate	802.11b = 11, 5.5, 2, 1 Mbps 802.11g = 54, 48, 36, 24, 18, 12, 9, 6 Mbps
MAC	CSMA/CA with ACK, RTS, CTS
Network Protocols	TCP/IP, ARP, ICMP, DHCP, DNS, UDAP, TFTP, UDP, PING
Receive Sensitivity	54Mb/s = -69dBm 6 Mb/s = -86dBm 1Mb/s = -86dBm
Security Protocols	Disabled, WEP 64 & 128bit, WPA (TKIP), WPA (AES), WPA2 (AES), 802.1x (EAP) Supplicant Supports WPA & WPA2 Enterprise supplicants EAP-TLS/MSCSHAPv2, EAP-TTLS/MSCSHAPv2, EAP-TTLS(MD5), EAP-PEAPv0/MSCSHAPv2, LEAP Zero host security footprint Supports Certificate, delivery and management
Antenna	Two (2) U.FL coaxial connectors, 50 ohms, supports diversity
Supply	3.3VDC +/-5%, 850mA (MAX)
Supply In-rush Current	3000mA (MAX) for 20ms
DC Characteristics	Operating Current (Tx, 802.11g) = 500mA Typ. Operating Current (Rx, 802.11g) = 530mA Typ. Power Save (Snooze) = 10mA Typ. Power Down (Sleep) = 1mA Typ.
Environmental	Operating Temperature: -40°C - +85°C, Storage: -55°C - +150°C Relative humidity: 5% - 95% (non-condensing) Vibration: 20G peak-to-peak, 20Hz-2KHz swept Shock: 1500G peak-to-peak, 0.5mS duration
Interface	10/100 Ethernet on board PHY (auto rate detection)
Digital I/O	8 GPIO
LED Indicators	4 indicator LED signals (RF_ACT, POST, CONNECT, RF_LINK)
Connector	36 pin High Density SMT connector from Hirose (DF12-36DS-0.5V), 4mm Height
Agency Approvals	Worldwide Certification Support- FCC Part 15 Class B Sub C Modular Approval, IOC, CE, ETSI, ROHS, WEEE