



Chipsmall Limited consists of a professional team with an average of over 10 year of expertise in the distribution of electronic components. Based in Hongkong, we have already established firm and mutual-benefit business relationships with customers from,Europe,America and south Asia,supplying obsolete and hard-to-find components to meet their specific needs.

With the principle of "Quality Parts,Customers Priority,Honest Operation,and Considerate Service",our business mainly focus on the distribution of electronic components. Line cards we deal with include Microchip,ALPS,ROHM,Xilinx,Pulse,ON,Everlight and Freescale. Main products comprise IC,Modules,Potentiometer,IC Socket,Relay,Connector.Our parts cover such applications as commercial,industrial, and automotives areas.

We are looking forward to setting up business relationship with you and hope to provide you with the best service and solution. Let us make a better world for our industry!



Contact us

Tel: +86-755-8981 8866 Fax: +86-755-8427 6832

Email & Skype: info@chipsmall.com Web: www.chipsmall.com

Address: A1208, Overseas Decoration Building, #122 Zhenhua RD., Futian, Shenzhen, China





Limitless™ Wireless
Heavy-Duty Limit Switches
WLS Series



Limitless™ WLS Series

Wireless Limit Switches

The Limitless™ product line combines the best of MICRO SWITCH™ heavy-duty limit switches with the latest commercial off-the-shelf wireless technology. Wireless enabled limit switches can be used for position sensing and presence/absence detection for an endless number of applications.

The Limitless™ Series is especially beneficial for remote monitoring applications where wiring or wire maintenance is not physically possible or economically feasible. Combining this greater flexibility with proven harsh duty packaging can result in increased efficiencies and improved safety for machines, equipment, OEMs, and operators.

What makes our wireless solutions better?

- Enables control and/or notification from remote parts of applications/machinery/manufacturing plants, where wiring is too costly or not possible
- Ability to reconfigure and network multiple switches and interfaces with unique addresses that allows for adding, subtracting, or relocating Limitless™ inputs easily
- Limit, eyelet pull, and non-contact switches along with single switch adapters allow for multiple wireless solutions to accommodate almost any application
- Reduced installation and maintenance costs eliminate the need to wire switches, install conduit, apply strain relief, mounting clips, connectors, junction boxes, etc.
- Eliminates issues with wire connection integrity and cable degradation on moving equipment



INDUSTRY STANDARD
VALUE • RELIABLE

Features and Benefits

WIRELESS DESIGN

Radio (license-free and global): WPAN 802.15.4, 2.4 GHz, point-to-point to deliver **reliable, flexible, and secure wireless transmission**. Offers control from remote locations where wiring is too costly or not practical (up to 305 m [1000 ft]).

SEALED FOR HARSH ENVIRONMENTS

The Limitless™ Series features **industrial and NEMA ratings**, sealed zinc die-cast and powder coated housings with direct or remote mounted antenna options.

Range of 305 m [1000 ft]

REMOTE CONTROL AND MONITORING

When paired with the Limitless™ Monitor or Receiver, the WLS product line can enable users to monitor and/or control equipment, access points, and presence/absence detection in remote locations where wiring is too costly or impractical to install. The WLS Series is designed to consume ultra-low power that helps to prolong battery life and has **direct or remote mounted antenna options**.

Consumes ultra-low power to prolong battery life

DESIGN OPTIONS

The WLS Series offers a broad range of actuator styles. Side rotary, top plunger, eyelet pull, wobble stick, single switch adapter, and non-contact switch are all available within the product line. Actuator heads on most models can be **rotated in 90° increments** to allow for flexibility in applications. Multiple actuators can also be applied to any side rotary WLS Limitless™ switch.

CONFIGURABILITY

All of the WLS Series Limitless™ switches can be easily paired with a WPMM monitor or WDRR receiver providing multiple inputs that **easily allow for adding, removing, or relocating Limitless™ switches**. This unique feature helps to eliminate issues with wire connection integrity on moving equipment.

REDUCES COSTS

With no wires, conduit, strain relief, connectors, or junction boxes to install or maintain, the WLS Series can **reduce maintenance costs and inventory** associated with maintaining and repairing equipment and facilities.

Limitless™ WLS Series • Heavy-Duty Limit Switch

Potential Applications

with elements of control, notification, and/or setup



- Valve position
- Crane boom/jib/skew position
- Safety shower monitoring
- Lifts
- Material handling
- Presses
- CNC equipment
- Construction/Agricultural equipment
- Movable machinery
- Door position
- Hose attachment verification
- Remote or temporary equipment



Table 1. WLS Series Specifications

Characteristic	Parameter
Series name	WLS Series
Product type	Limitless™ Wireless Heavy-Duty Limit Switches
Availability	global, license-free bands
Operating force	see specification tables on page 6-7
Actuator	side rotary, top plunger, top roller plunger, top adjustable plunger, side plunger, wobble stick
Lever type	rotary lever included with side rotary – other lever options available
Housing material	zinc die-cast head and body, phosphate treated and powder coated
Housing type	EN 50041
Radio	WPAN 802.15.4; 2.4 GHz
Antenna type	direct or remote mount antenna options; omni directional
Signal range*	305 meters [1000 ft] clear "line of sight"*** between switch and receiver using a 2.2 dBi integral antenna
Battery	3.5 Vdc Lithium Thionyl Chloride; 2/3 AA size (est. life = 1 year) Manufactured by Uniwell, part number DEV-10-0009; Green Energy p/n ER14335M; Honeywell p/n WBT1
Sealing	IP67; NEMA 1, 3, 4, 6, 6P, 12, 13
EMC	Latest applicable standards: EN 300 328, V1.7.1; EN 61326-1 (2006); EN 301 489-1, V1.8.1; EN 301 489-17, V2.1.1
Shock	IEC 60068-2-27; half sine, 10 g, 6 mS, 3 axis
Vibration	IEC 60068-2-6; 10-500Hz w/ 0,35 mm peak to peak, 58-500 Hz-5g
Operating temperature	-40 °C to 85 °C [-40 °F to 185 °F]
Agency approvals and standards	FCC 15.247: United States of America • IC RSS 210: Canada ETSI, CE mark: European countries • ACMA, C-TICK: Australia, New Zealand IDA: Singapore • COFETEL: Mexico WPC: India • ANATEL: Brazil SRRC: China • KCC: South Korea
UNSPSC code	20142601
UNSPSC commodity	20142601
Sealed	Industrial

*Actual range may vary depending upon antennas, cables, and topography.

** "Line of sight" is not mandatory to fully utilize the Limitless™ technology and thus testing in the actual application will determine suitability.

Limitless™ Wireless Heavy-Duty Limit Switches

PRODUCT NOMENCLATURE

WLS	1	A	00	A	A	1	3	A
Switch type	Gen Code	RF Code	Antenna type code*	Country use code	Operating head code	Actuator code	Modification code	Specials
WLS Series Wireless	1 Version 1	A 2.4 GHz; IEEE 802.15.4	00 No antenna; RP-SMA connector jack	A US, Canada, Mexico	A Side rotary, momentary	See WLS actuator code table for details.	Not applicable	Not applicable
			01 2.2 dBi omni w/ switch mount; straight design	B All other approved countries ^{1, 2, 3}	C Top plunger, plain	Actuators for operating head code "A" only; insert actuator code from table below.	3 Head assembled with actuator to right side	BT1 M12 Micro connector on top of head for external switch connection*
			02 2.2 dBi omni w/ switch mount; tilt/swivel	*Use with antenna type codes 00 - 03, 05, 10, 11 only; usage also allowed in Country Code A.	D Top plunger, roller		4 Head assembled with actuator to left side	BT2 M12 Micro connector on side of head for external switch connection*
			03 3.0 dBi omni w/ remote mag. adhesive mount 9.8 ft cable		*Some countries require specific communication certifications. Contact Honeywell for existing certification information.		E Side plunger, momentary	5 Head assembled with actuator to mounting surface
			04 5.5 dBi omni w/ remote mag. mount, tilt/swivel 5 ft cable	*If Limitless™ devices are used on machinery that may be shipped globally, use country code "B".			J Wobble stick	6 Roller perpendicular to mounting surface
			05 5.5 dBi omni w/ remote mag. mount, tilt/swivel 10ft cable				N Side rotary, maintained	
			06 9.0 dBi omni w/ remote mag. mount, tilt/swivel 5 ft cable		V Top plunger, adjustable			RS2 Reed switch target on side of head
			07 9.0 dBi omni w/ remote mag. mount, tilt/swivel 10ft cable					PO1 Eyelet pull operating head (low force, 7 lb ref.)
			08 8.0 dBi omni w/ remote bkt. mount, str. design 3 ft cable					PO2 Eyelet pull operating head (low force, 18 lb ref.)
			09 8.0 dBi omni w/ remote bkt. mount, str. design 11 ft cable					
			10 2.2 dBi omni w/ remote bracket mount, straight design, 10 ft cable					
			11 0 dBi omni w/ switch mount; straight design					

* See Table 11 for additional information.

Table 2. WLS Series Actuator Code Table









Code	Catalog Listing	Material	Roller Dia. (in)	Roller Width (in)	Roller Mounting
Fixed 1.5 inch radius					
1	LSZ51	Rollerless	n/a	n/a	n/a
1A	LSZ51A	Nylon	0.75	0.25	Front
1B	LSZ51B	Steel	0.75	0.25	Front
1C	LSZ51C	Nylon	0.75	0.25	Back
1D	LSZ51D	Steel	0.75	0.25	Back
1F	LSZ51F	Nylon	1.0	0.520	Front
1G	LSZ51G	Nylon	1.5	0.25	Front
1J	LSZ51J	Nylon	1.0	0.520	Back
1L	LSZ51L	Ball bearing	0.75	0.25	Back
1M	LSZ51M	Nylon	0.75	1.25	Back
1N	LSZ51N	Steel	0.75	1.25	Front
1P	LSZ51P	Nylon	0.75	0.50	Front
Adjustable 1.5 in to 3.5 in radius					
2	LSZ52	Rollerless	n/a	n/a	n/a
2A	LSZ52A	Nylon	0.75	0.25	Back
2B	LSZ52B	Steel	0.75	0.25	Back
2C	LSZ52C	Nylon	0.75	0.25	Front
2D	LSZ52D	Steel	0.75	0.25	Front
2E	LSZ52E	Nylon	0.75	1.30	Front
2J	LSZ52J	Nylon	1.0	0.50	Front
2K	LSZ52K	Nylon	1.5	0.25	Front
2L	LSZ52L	Ball bearing	0.75	0.25	Front
2M	LSZ52M	Nylon	2.0	0.25	Front
2N	LSZ52N	Nylon	0.75	0.50	Front
Yoke – 1.5 in radius					
3A	LSZ53A	Nylon	0.75	0.25	Front/Back
3B	LSZ53B	Steel	0.75	0.25	Front/Back
3D	LSZ53D	Steel	0.75	0.25	Front/Front

Code	Catalog Listing	Material	Roller Dia. (in)	Roller Width (in)	Roller Mounting
Yoke – 1.5 in radius, continued					
3E	LSZ53E	Nylon	0.75	0.25	Back/Front
3M	LSZ53M	Nylon	0.75	1.25	Back/Front
3P	LSZ53P	Steel	0.75	0.25	Back/Back
3S	LSZ53S	Nylon	0.75	0.25	Back/Back
Rod					
4	LSZ54	Hub only	n/a	n/a	n/a
4M	LSZ54M	Alum, 5.5 in	n/a	n/a	n/a
4N	LSZ54N	Stainless, 13 in	n/a	n/a	n/a
4R	LSZ54R	Spring Wire, 12 in	n/a	n/a	n/a
4V	LSZ54V	Flex cable, 4.8 in	n/a	n/a	n/a
Offset – 1.5 in radius					
5	LSZ55	Rollerless	n/a	n/a	n/a
5A	LSZ55A	Nylon	0.75	0.25	Back
5B	LSZ55B	Steel	0.75	0.25	Back
5C	LSZ55C	Nylon	0.75	0.25	Front
5D	LSZ55D	Steel	0.75	0.25	Front
5E	LSZ55E	Nylon	0.75	0.50	Front
5K	LSZ55K	Nylon	1.5	0.25	Front
Wobble stick					
7A	LSZ1JGA	Delrin™ rod, 5.5	n/a	n/a	n/a
7M	LSZ1JGM	Spring wire, 13.0	n/a	n/a	n/a
7N	LSZ1JGN	Cable, 5.5 in.	n/a	n/a	n/a
Short fixed - 1.3 in radius					
9A	LSZ59A	Nylon	0.75	0.25	Front
9B	LSZ59B	Steel	0.75	0.25	Front
9C	LSZ59C	Nylon	0.75	0.25	Back
9D	LSZ59D	Steel	0.75	0.25	Back

* Connect to SPDT (form C) gold contact switch; 3.6 Vdc, 30 mA max. electrical load

WLS Series

Table 3. WLS Series Order Guide

Photo	Part Number*	Operating Head	Actuator/Lever	Antenna Type
	WLS1A01AA1A	side rotary - momentary	Fixed 33,1 mm [1.5 in] lever with nylon roller	2.2 dBi omni, straight
	WLS1A02AA1A	side rotary - momentary	Fixed 33,1 mm [1.5 in] lever with nylon roller	2.2 dBi omni, tilt & swivel
	WLS1A04AA1A	side rotary - momentary	Fixed 33,1 mm [1.5 in] lever with nylon roller	5.5 dBi omni w/ remote magnetic mount, tilt & swivel, 5 ft cable
	WLS1A11AA1A	side rotary - momentary	Fixed 33,1 mm [1.5 in] lever with nylon roller	0.0 dBi omni, straight
	WLS1A01AA1B	side rotary - momentary	Fixed 33,1 mm [1.5 in] lever with steel roller	2.2 dBi omni, straight
	WLS1A02AA1B	side rotary - momentary	Fixed 33,1 mm [1.5 in] lever with steel roller	2.2 dBi omni, tilt & swivel
	WLS1A04AA1B	side rotary - momentary	Fixed 33,1 mm [1.5 in] lever with steel roller	5.5 dBi omni w/ remote magnetic mount, tilt & swivel, 5 ft cable
	WLS1A11AA1B	side rotary - momentary	Fixed 33,1 mm [1.5 in] lever with steel roller	0.0 dBi omni, straight
	WLS1A001AA2A	side rotary - momentary	Adjustable 88,9 mm [3.5 in] lever with nylon roller	2.2 dBi omni, straight
	WLS1A02AA2A	side rotary - momentary	Adjustable 88,9 mm [3.5 in] lever with nylon roller	2.2 dBi omni, tilt & swivel
	WLS1A04AA2A	side rotary - momentary	Adjustable 88,9 mm [3.5 in] lever with nylon roller	5.5 dBi omni w/ remote magnetic mount, tilt & swivel, 5 ft cable
	WLS1A11AA2A	side rotary - momentary	Adjustable 88,9 mm [3.5 in] lever with nylon roller	0.0 dBi omni, straight
	WLS1A01AA2B	side rotary - momentary	Adjustable 88,9 mm [3.5 in] lever with steel roller	2.2 dBi omni, straight
	WLS1A02AA2B	side rotary - momentary	Adjustable 88,9 mm [3.5 in] lever with steel roller	2.2 dBi omni, tilt & swivel
	WLS1A04AA2B	side rotary - momentary	Adjustable 88,9 mm [3.5 in] lever with steel roller	5.5 dBi omni w/ remote magnetic mount, tilt & swivel, 5 ft cable
	WLS1A11AA2B	side rotary - momentary	Adjustable 88,9 mm [3.5 in] lever with steel roller	0.0 dBi omni, straight
	WLS1A01AA4M	side rotary - momentary	140 mm [5.5 in] aluminum adjustable rod	2.2 dBi omni, straight
	WLS1A02AA4M	side rotary - momentary	140 mm [5.5 in] aluminum adjustable rod	2.2 dBi omni, tilt & swivel
	WLS1A01AA4N	side rotary - momentary	330 mm [13.0 in] stainless steel rod	2.2 dBi omni, straight
	WLS1A02AA4N	side rotary - momentary	330 mm [13.0 in] stainless steel rod	2.2 dBi omni, tilt & swivel
	WLS1A11AA4N	side rotary - momentary	330 mm [13.0 in] stainless steel rod	0.0 dBi omni, straight
	WLS1A02AB	side pin plunger	–	2.2 dBi omni, tilt & swivel
	WLS1A01AC	top pin plunger	–	2.2 dBi omni, straight
	WLS1A02AC	top pin plunger	–	2.2 dBi omni, tilt & swivel
	WLS1A04AC	top pin plunger	–	5.5 dBi omni w/ remote magnetic mount, tilt & swivel, 5 ft cable
	WLS1A11AC	top pin plunger	–	0.0 dBi omni, straight
	WLS1A01AD	top roller plunger	–	2.2 dBi omni, straight
	WLS1A02AD	top roller plunger	–	2.2 dBi omni, tilt & swivel
	WLS1A04AD	top roller plunger	–	5.5 dBi omni w/ remote magnetic mount, tilt & swivel, 5 ft cable
	WLS1A11AD	top roller plunger	–	0.0 dBi omni, straight
	WLS1A02AJ7M	wobble - wire	Ø2,0 mm [Ø0.075 in] x 330 mm [13.0 in]	2.2 dBi omni, tilt & swivel
	WLS1A11AJ7A	wobble - thermoplastic rod	Ø6,35 mm x 140 mm [Ø0.25 in x 5.5 in]	0.0 dBi omni, straight

* To order products approved for use outside of the US/Canada/Mexico (A code), simply substitute the appropriate letter after reviewing the product approvals and antenna guidelines contained in this document. B = All other approved countries

NOTE: Switches are also available without antennas. Contact Honeywell Customer Service or an authorized distributor for details.

WLS Series

DIMENSIONS

Figure 1. Limitless™ WLS Series Side Rotary

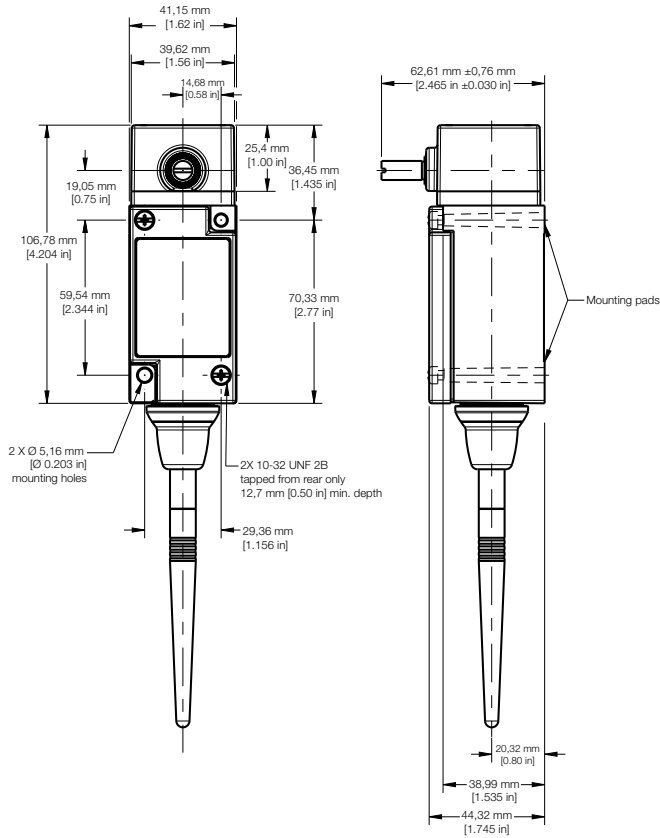

Figure 2. Limitless™ WLS Series Top Adjustable Plunger Head

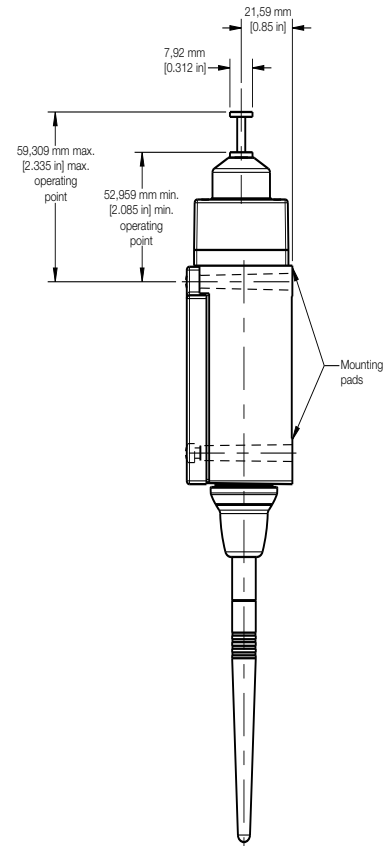

Figure 3. Limitless™ WLS Series Top Roller Plunger

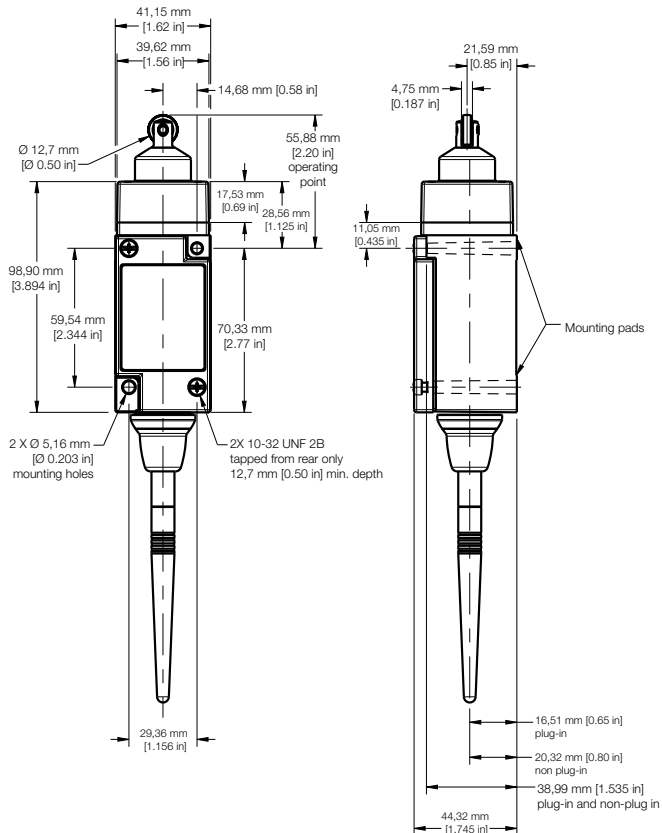
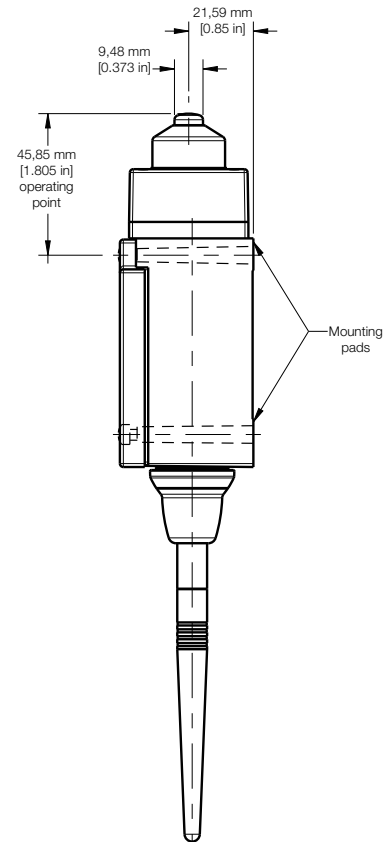

Figure 4. Limitless™ WLS Series Top Plunger Head



Limitless™ Wireless Heavy-Duty Limit Switches

Figure 5. Limitless™ WLS Series Side Plunger

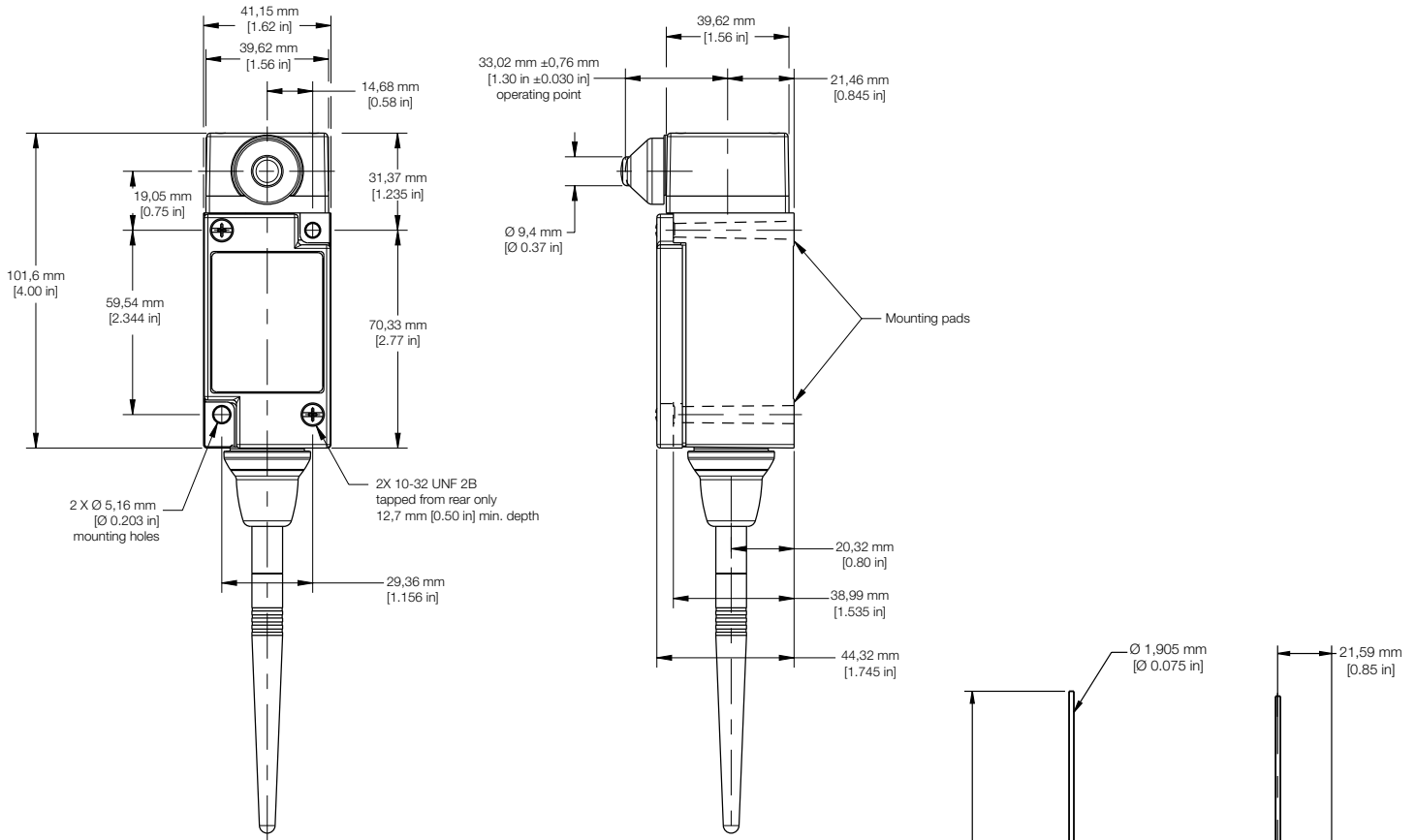
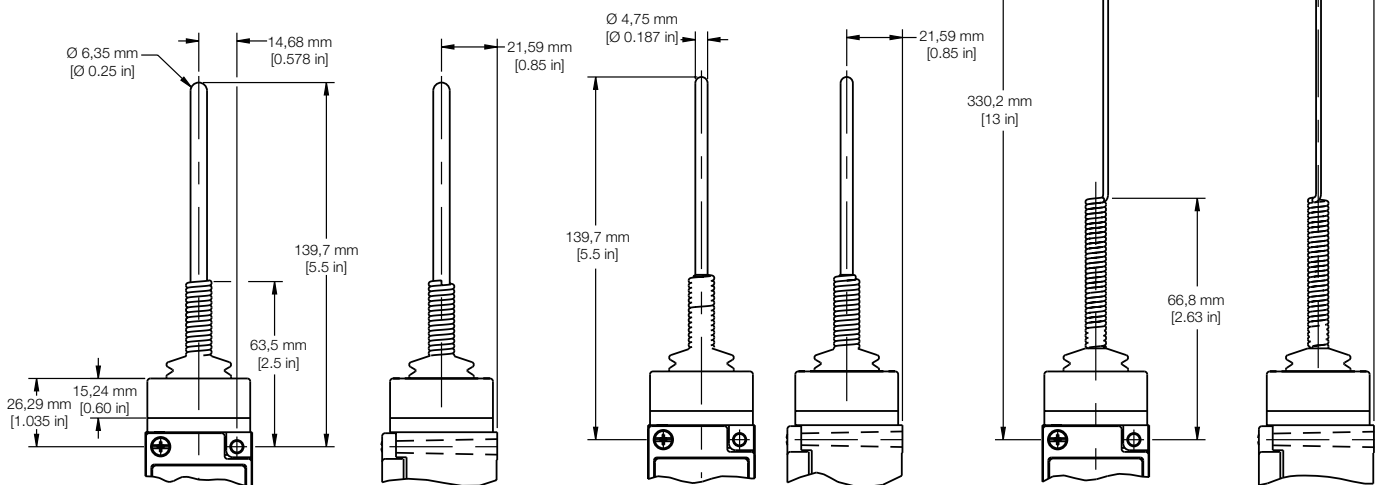

Figure 6. Limitless™ WLS Series Wobblers



**Operating Head Code J
Actuator Code 7A**

**Operating Head Code J
Actuator Code 7N**

**Operating Head Code J
Actuator Code 7M**

WLS Series

Table 4. WLS Series Available Levers

							
Fixed lever LSZ51A - front mount nylon roller LSZ51B - front mount steel roller LSZ51C - back mount nylon roller LSZ51D - back mount steel roller	Short fixed lever LSZ59A - front mount nylon roller LSZ59B - front mount steel roller LSZ59C - back mount nylon roller LSZ59D - back mount steel roller	Offset lever LSZ55A - back mount nylon roller LSZ55B - back mount steel roller LSZ55C - front mount nylon roller LSZ55D - front mount steel roller	Yoke lever LSZ53A - front/back mount nylon rollers LSZ53B - front/back mount steel rollers LSZ53D - front/front mount steel rollers				
							
One-way lever LSZ60A - nylon roller LSZ60B - steel roller	Adjustable lever LSZ52A - back mount nylon roller LSZ52B - back mount steel roller LSZ52C - front mount nylon roller LSZ52D - front mount steel roller	Spoke lever LSZ69CA - 152 mm [6 in]					
							
LSZ54M aluminum rod 140 mm [5.5 in]	LSZ52J adjustable lever, nylon roller 25,4 mm [1 in]	LSZ52K adjustable lever, nylon roller 38,1 mm [1.5 in]	LSZ61 loop 152 mm [6 in]	LSZ67CA** Plastic conveyor roller	LSZ54N stainless steel rod 330 mm [13 in]	LSZ54R spring wire 305 mm [12 in]	LSZ68 rod w/ spring 305 mm [12 in]

** May require orientation of switch and lever to enable gravity to help restore switch's free position.

Limitless™ WLS Series • Eyelet Pull Limit Switch

Honeywell Limitless™ WLS Series Heavy Duty Wireless Limit Switches with an eyelet pull operating head can be used to attach a rope, cable, or chain. It also can be used on cranes as an anti-two-block (A2B) switch.

Potential Applications



- Cranes: A2B (anti-two-block) switch
- Rope pull: door activation switch
- Cable pull: production stop applications (e.g., quality, broken tool, maintenance, out of parts);
**not applicable to human safety-stop applications



Table 5. WLS Series with Eyelet Pull Specifications

Characteristic	Parameter
Operating characteristics	operating force: 7 lb. approx. or 18 lb. approx.
Actuator	momentary eyelet pull operating head (pull eyelet in-line with shaft to prevent damage)
Housing material	zinc die-cast head and body, phosphate treated and powder coated
Radio	WPAN 802.15.4; 2.4 GHz
Communication agency approval	FCC 15.247: United States of America IC RSS 210: Canada ETSI, CE mark: European countries ACMA, C-TICK: Australia, New Zealand COFETEL: Mexico WPC: India ANATEL: Brazil SRRC: China KCC: South Korea
Antenna type	RP-SMA jack for direct or remote mount antenna options; omni-directional
Signal range*	In excess of 305 m [1000 ft] "line-of-sight" communication between Limitless™ switches and monitor
Battery	3.6 Vdc Lithium Thionyl Chloride; 2/3 AA size (est. life = 1 year) Manufactured by Uniwell, p/n DEV-10-0009; Green Energy, p/n ER14335M; Honeywell, p/n WBT1
Sealing	IP67/IP68; NEMA 1, 4, 6, 6P, 12, 13
EMC	Latest applicable standards: EN 300 328, V1.7.1; EN 61326-1 (2006); EN 301 489-1, V1.8.1; EN 301 489-17, V2.1.1
Shock	IEC 60068-2-27; half sine, 10 g, 6 mS, 3 axis
Vibration	IEC 60068-2-6; 10-500Hz w/ 0,35 mm peak-to-peak, 58-500 Hz- 5g
Operating temperature	-40 °C to 85 °C [-40 °F to 185 °F]

*Actual range may vary depending upon antennas, cables, and topography.

** "Line of sight" is not mandatory to fully utilize the Limitless™ technology and thus testing in the actual application will determine suitability.

WLS Series

Table 6. WLS Series with Eyelet Pull Order Guide

Photo	Part Number	Antenna Type	For Use In	Full Travel max.	Free Position	Oper. Force max.	Head assembly
	WLS 1A11AQ-4P01	0 dBi omni	US, Canada, Mexico	83,82 mm [3.30 in]	74,17 mm [2.92 in]	7 lb	w/ actuator to left side
	WLS1A11AQ-P01	0 dBi omni	US, Canada, Mexico	83,82 mm [3.30 in]	74,17 mm [2.92 in]	7 lb	w/ actuator towards nameplate
	WLS1A11AQ-P02	0 dBi omni	US, Canada, Mexico	83,82 mm [3.30 in]	74,17 mm [2.92 in]	18 lb	w/ actuator towards nameplate
	WLS1A11BQ-4P01	0 dBi omni	All other approved countries	83,82 mm [3.30 in]	74,17 mm [2.92 in]	7 lb	w/ actuator to left side
	WLS1A11BQ-P01	0 dBi omni	All other approved countries	83,82 mm [3.30 in]	74,17 mm [2.92 in]	7 lb	w/ actuator towards nameplate
	WLS1A11BQ-P02	0 dBi omni	All other approved countries	83,82 mm [3.30 in]	74,17 mm [2.92 in]	18 lb	w/ actuator towards nameplate

Limitless™ Wireless Heavy-Duty Limit Switches

Figure 7. Limitless™ WLS Series with Eyelet Pull

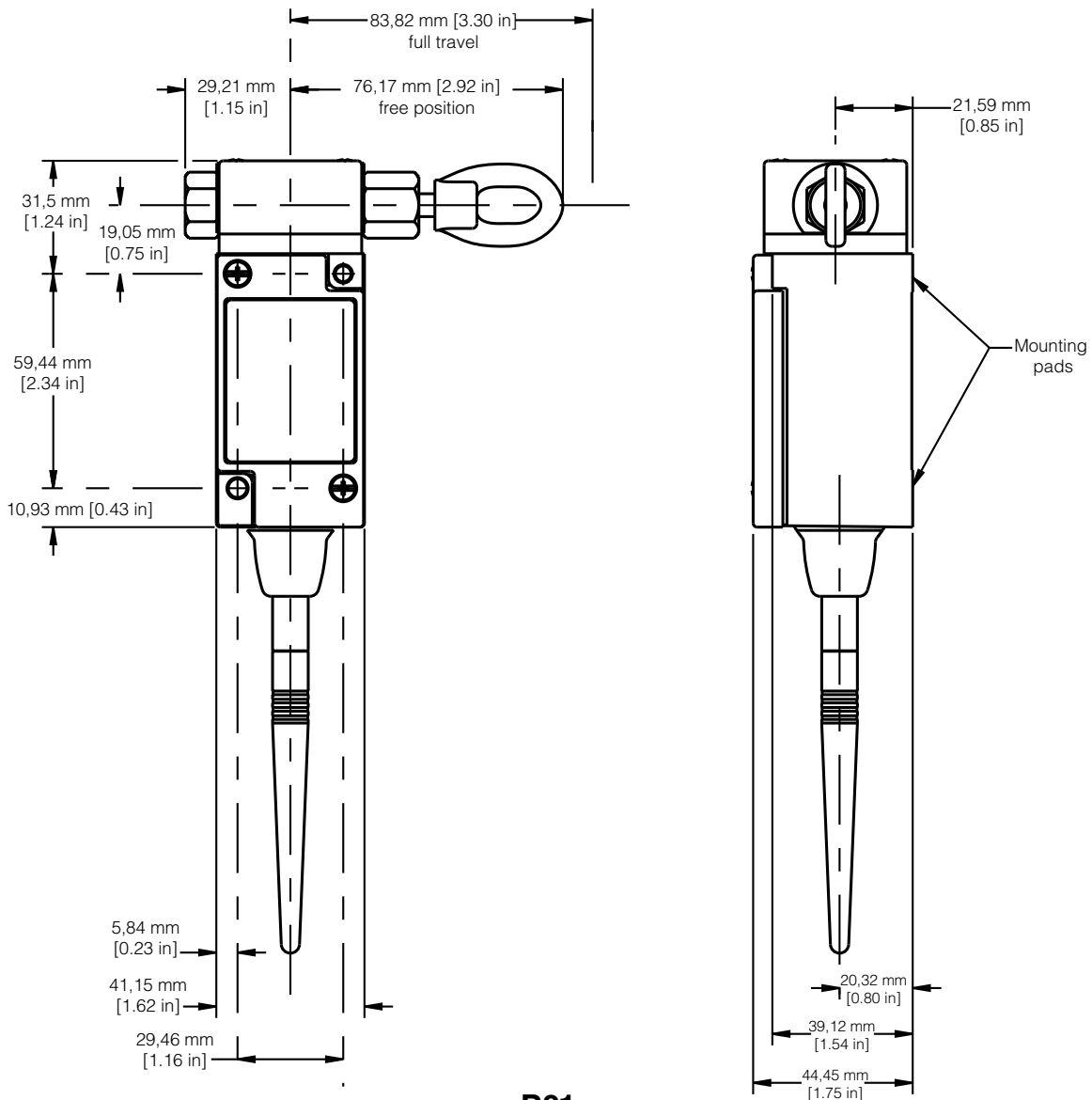

P01

With Eyelet Pull Operating Head

assembled per modification code 3

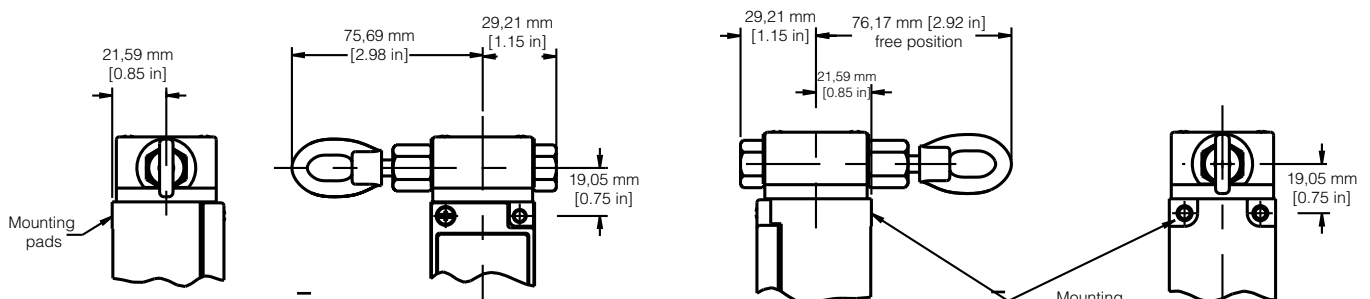

P01

With Eyelet Pull Operating Head

assembled per modification code 4

P01

With Eyelet Pull Operating Head

assembled per modification code 5

Limitless™ WLS Series • Non-Contact Limit Switch

Honeywell's Limitless™ Wireless Non-Contact Switch provides non-contact presence/absence detection of a variety of different magnet styles and magnetic actuators installed on the end-users' product, machine, equipment, etc. The Limitless™ WLS Non-Contact Switch's design features an industrial grade reed switch. Customers can choose how the reed switch is oriented within the switch's plastic head, i.e., either top- or side-sensing. Combining this greater flexibility with proven harsh-duty packaging can result in increased efficiencies and improved safety for industrial machines, equipment, OEMs, and operators.

Potential Applications



- Machine tools
- Packaging machinery
- Lifts
- Ag/construction equipment
- Industrial machines



Table 7. WLS Series Non-Contact Switch Specifications

Characteristic	Parameter
Operating characteristics	operating point: 3,81 mm [0.15 in] min.; release point: 15,24 mm [0.60 in] max. with use of WMG1 magnet (included with WLS Series Non-Contact Switch)
Sensing target	top and side of head
Housing material	zinc body is phosphate treated and powder coated; 30 % glass-filled PBT plastic head
Radio	WPAN 802.15.4; 2.4 GHz
Communication agency approval	FCC 15.247: United States of America IC RSS 210: Canada ETSI, CE mark: European countries ACMA, C-TICK: Australia, New Zealand COFETEL: Mexico WPC: India ANATEL: Brazil SRRC: China KCC: South Korea
Antenna type	RP-SMA jack for direct or remote mount antenna options; omni-directional standard
Signal range*	In excess of 305 m [1000 ft] "line-of-sight"*** communication between Limitless™ switches and monitor
Battery	3.6 Vdc Lithium Thionyl Chloride; 2/3 AA size (est. life = 1 year) Manufactured by Uniwell, p/n DEV-10-0009; Green Energy, p/n ER14335M; Honeywell, p/n WBT1
Sealing	IP67; NEMA 1, 4, 12, 13
EMC	Latest applicable standards: EN 300 328, V1.7.1; EN 61326-1 (2006); EN 301 489-1, V1.8.1; EN 301 489-17, V2.1.1
Shock	IEC 60068-2-27; half sine, 10 g, 6 mS, 3 axis
Vibration	IEC 60068-2-6; 10-500Hz w/ 0,35 mm peak-to-peak, 58-500 Hz- 5g
Operating temperature	-40 °C to 85 °C [-40 °F to 185 °F]

*Actual range may vary depending upon antennas, cables, and topography.

** "Line of sight" is not mandatory to fully utilize the Limitless™ technology and thus testing in the actual application will determine suitability.

Limitless™ Wireless Heavy-Duty Limit Switches

Table 8. WLS Series Non-Contact Switch Standard Listings

Photo	Part Number	Description
	WLS1A00AQRS1	Limitless™ WLS Series Non-Contact Switch with no antenna (RP-SMA connector jack) and a top sensing target, for use in US, Canada, and Mexico
	WLS1A00AQRS2	Limitless™ WLS Series Non-Contact Switch with no antenna (RP-SMA connector jack) and a side sensing target, for use in US, Canada, and Mexico
	WLS1A11AQRS1	Limitless™ WLS Series Non-Contact Switch with a 0 dBi antenna and a top sensing target, for use in US, Canada, and Mexico
	WLS1A11AQRS2	Limitless™ WLS Series Non-Contact Switch with a 0 dBi antenna and a side sensing target, for use in US, Canada, and Mexico
	WLS1A00BQRS1	Limitless™ WLS Series Non-Contact Switch with no antenna (RP-SMA connector jack) and a top sensing target, for use in all other approved countries
	WLS1A00BQRS2	Limitless™ WLS Series Non-Contact Switch with no antenna (RP-SMA connector jack) and a side sensing target, for use in all other approved countries
	WLS1A11BQRS1	Limitless™ WLS Series Non-Contact Switch with a 0 dBi antenna and a top sensing target, for use in all other approved countries
	WLS1A11BQRS2	Limitless™ WLS Series Non-Contact Switch with a 0 dBi antenna and a side sensing target, for use in all other approved countries
	WMG1	Limitless™ magnets for use with WLS Non-Contact Switch only: Operating point 3,81 mm [0.15 in] min.; Release point 15,24 mm [0.60 in] max.
	WMG2	Limitless™ magnets for use with WLS Non-Contact Switch only: Operating point 11,43 mm [0.45 in] min.; Release point 54,4 mm [1.0 in] max.

WLS Series

Figure 8. Limitless™ WLS Series Non-Contact Switch

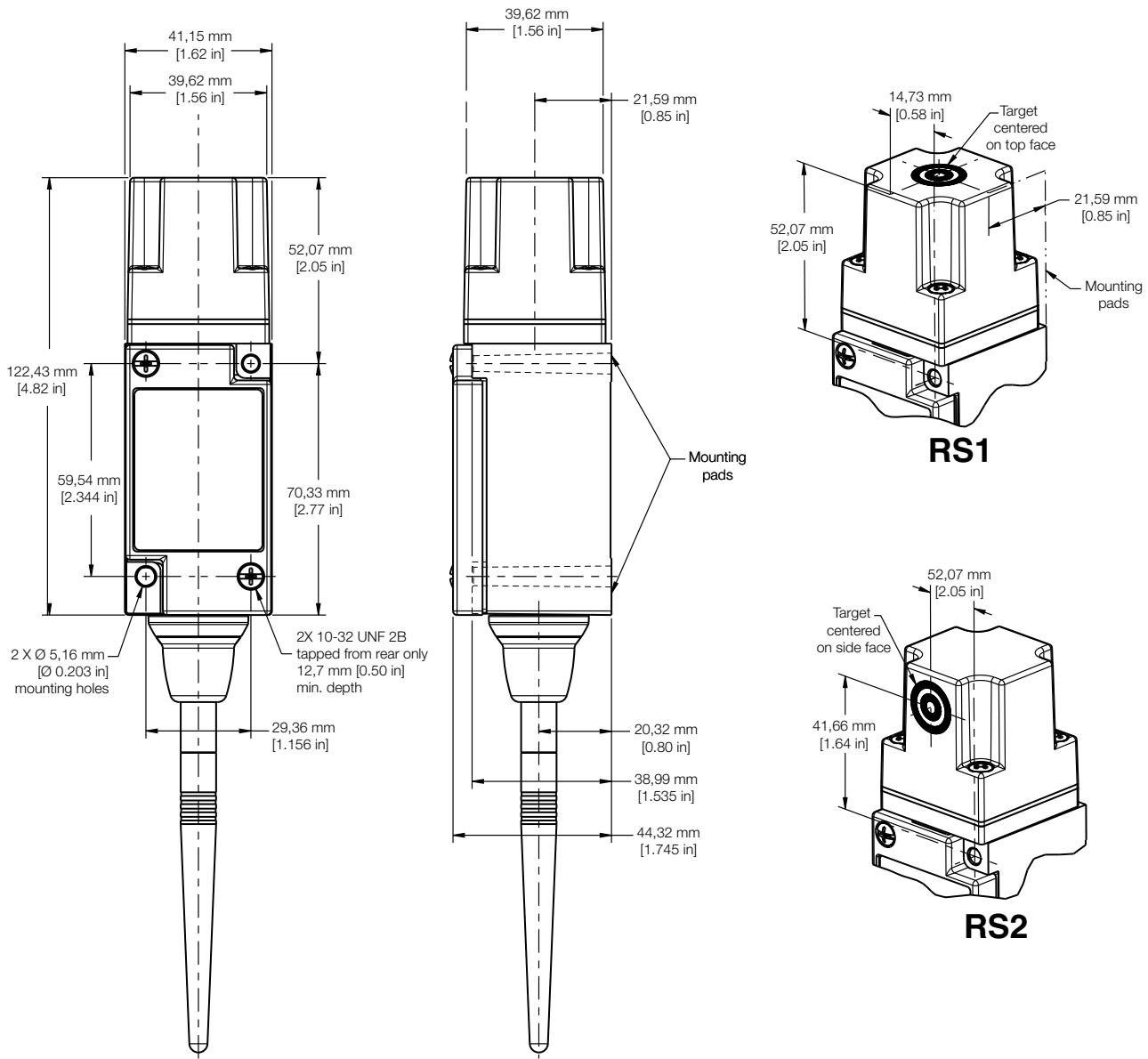

Limitless™ WLS Series • Single Switch Adapter

Honeywell's Limitless™ Single Switch Adapter can convert almost any electromechanical switch with low-energy contacts (i.e., gold) into a wireless switch. A user-supplied electromechanical switch is simply wired to the WLS Series Single Switch Adapter via the internal or external connections to then become a wireless-enabled switch for use with the Limitless™ WPMM or WDRR Series of monitors/receivers. The Limitless™ Single Switch Adapter can be used in a variety of industrial wireless limit switch applications such as reed, contact, pressure, door actuator, etc. Honeywell offers numerous styles of low-energy contact switches. From sealed heavy-duty limits to small basics and subminiature switches, Honeywell can provide a low-energy solution that is compatible with the Limitless™ Single Switch Adapter. Contact your Honeywell representative or distributor for details.

Potential Applications



- Agricultural equipment
- Construction equipment
- Door actuation (up/down) switch
- Industrial machines
- Lifts
- Machine tools
- Packaging machinery
- Wireless warehouse operations
- Wireless electro-mechanical switch operations (i.e. pressure switch, reed switch, basic switch, and/or limit switch)



Table 9. WLS Series Single Switch Adapter Specifications



Characteristic	Parameter
Electromechanical switch	SPDT (Form C) switch with low-energy contacts (i.e., gold) capable of reliably controlling a 3.6 Vdc @ 30 mA electrical load to ensure proper operation
Electrical connections	4-pin M12 micro-connector with three-pole, single keyway female receptacle Cable grip with internal screw connector Note: Maximum cable length 3 m [9.84 ft]. Cable diameter 8 mm [0.32 in] max./2,5 mm [0.10 in] min.
Housing material	zinc head is phosphate treated and powder coated; 30 % glass-filled PBT plastic head
Radio	WPAN 802.15.4; 2.4 GHz
Communication agency approval	FCC 15.247: United States of America • IC RSS 210: Canada ETSI, CE mark: European countries • ACMA, C-TICK: Australia, New Zealand COFETEL: Mexico • WPC: India ANATEL: Brazil • SRRC: China KCC: South Korea
Antenna type	RP-SMA jack for direct or remote mount antenna options; omni-directional standard
Signal range*	In excess of 305 m [1000 ft] "line-of-sight" communication between Limitless™ switches and monitor
Battery	3.6 Vdc Lithium Thionyl Chloride; 2/3 AA size (est. life = 1 year) Manufactured by Uniwell, p/n DEV-10-0009; Green Energy, p/n ER14335M; Honeywell, p/n WBT1
Sealing	IP67; NEMA 1, 4, 12, 13
EMC	Latest applicable standards: EN 300 328, V1.7.1; EN 61326-1 (2006); EN 301 489-1, V1.8.1; EN 301 489-17, V2.1.1
Shock	IEC 60068-2-27; half sine, 10 g, 6 mS, 3 axis
Vibration	IEC 60068-2-6; 10-500Hz w/ 0,35 mm peak-to-peak, 58-500 Hz - 5g
Operating temperature	-40 °C to 85 °C [-40 °F to 185 °F]

*Actual range may vary depending upon antennas, cables, and topography.

** "Line of sight" is not mandatory to fully utilize the Limitless™ technology and thus testing in the actual application will determine suitability.

WLS Series

Table 10. WLS Series Single Switch Adapter Standard Listings

Photo	Part Number	Description
	WLS1A00AQBT1	Limitless™ WLS Series Single Switch Adapter, no antenna, internal battery with M12 micro-connector on top of head for use in US, Canada, and Mexico
	WLS1A00BQBT1	Limitless™ WLS Series Single Switch Adapter, no antenna, internal battery with M12 micro-connector on top of head for use in all other approved countries
	WLS1A02AQBT1	Limitless™ WLS Series Single Switch Adapter, 2.2 dBi tilt/swivel antenna, internal battery with M12 micro-connector on top of head for use in US, Canada, and Mexico
	WLS1A02BQBT1	Limitless™ WLS Series Single Switch Adapter, 2.2 dBi tilt/swivel antenna, internal battery with M12 micro-connector on top of head for use in all other approved countries
	WLS1A11AQBT1	Limitless™ WLS Series Single Switch Adapter, 0 dBi straight antenna, internal battery with M12 micro-connector on top of head for use in US, Canada, and Mexico
	WLS1A11BQBT1	Limitless™ WLS Series Single Switch Adapter, 0 dBi straight antenna, internal battery with M12 micro-connector on top of head for use in all other approved countries
	WLS1A00AQBT2	Limitless™ WLS Series Single Switch Adapter, no antenna, internal battery with M12 side micro-connector on top of head for use in US, Canada, and Mexico
	WLS1A02AQBT2	Limitless™ WLS Series Single Switch Adapter, 2.2 dBi tilt/swivel antenna, internal battery with M12 side micro-connector on top of head for use in US, Canada, and Mexico
	WLS1A11AQBT2	Limitless™ WLS Series Single Switch Adapter, 0 dBi straight antenna, internal battery with M12 side micro-connector on top of head for use in US, Canada, and Mexico
	WLS1A00AQBT3	Limitless™ WLS Series Single Switch Adapter, no antenna, internal battery with cable grip on top of head for use in US, Canada, and Mexico
	WLS1A00BQBT3	Limitless™ WLS Series Single Switch Adapter, no antenna, internal battery with cable grip on top of head for use in all other approved countries
	WLS1A02AQBT3	Limitless™ WLS Series Single Switch Adapter, 2.2 dBi tilt/swivel antenna, internal battery with cable grip on top of head for use in US, Canada, and Mexico
	WLS1A02BQBT3	Limitless™ WLS Series Single Switch Adapter, 2.2 dBi tilt/swivel antenna, internal battery with cable grip on top of head for use in all other approved countries
	WLS1A11AQBT3	Limitless™ WLS Series Single Switch Adapter, 0 dBi straight antenna, internal battery with cable grip on top of head for use in US, Canada, and Mexico
	WLS1A11BQBT3	Limitless™ WLS Series Single Switch Adapter, 0 dBi straight antenna, internal battery with cable grip on top of head for use in all other approved countries
	WLS1A00AQBT4	Limitless™ WLS Series Single Switch Adapter, no antenna, internal battery with cable grip on side of head for use in US, Canada, and Mexico
	WLS1A02AQBT4	Limitless™ WLS Series Single Switch Adapter, 2.2 dBi tilt/swivel antenna, internal battery with cable grip on side of head for use in all other approved countries
	WLS1A11AQBT4	Limitless™ WLS Series Single Switch Adapter, 0 dBi straight antenna, internal battery with cable grip on side of head for use in US, Canada, and Mexico

Limitless™ Wireless Heavy-Duty Limit Switches



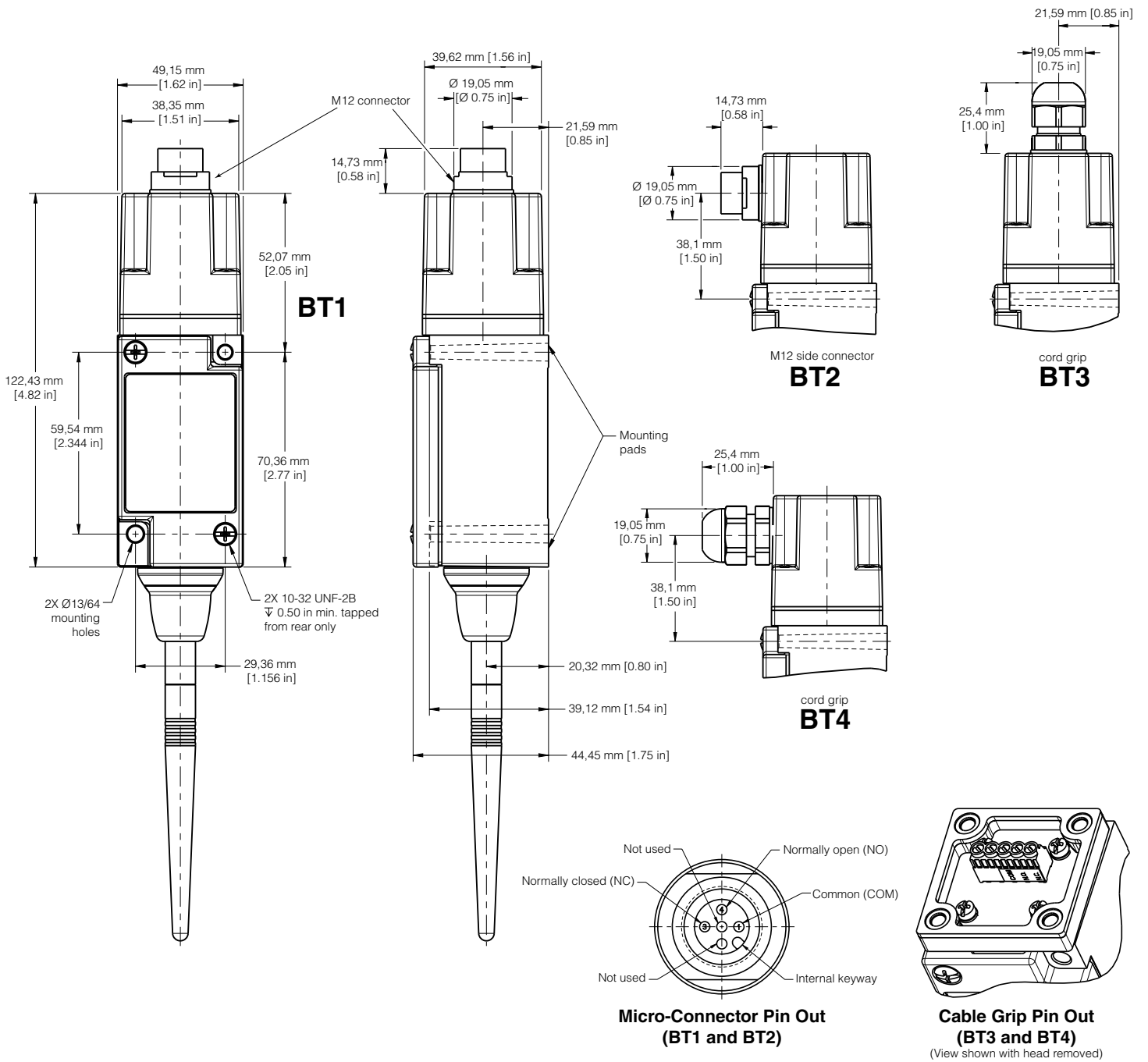







Figure 9. Limitless™ WLS Series Single Switch Adapter



WLS Series

Table 11. Antenna Listings/Order Code Specifications

Antennas can be ordered with the Limitless™ Wireless switches by inserting the **Antenna Type Code** into the part number as shown in the nomenclature. Also, switches can be ordered without antennas, by using the “00” Antenna Type Code in the part number. Antennas may also be ordered separately using the **Part Numbers** below.

	Part Number (if ordered separately)	Antenna Type Code (if ordered with a wireless switch)		Antenna Design	Antenna Gain (dBi)	Connector/ Mounting	Dimensions
	WAN01RSP	01		straight	2.2	RP-SMA plug/direct mount	Ø 9,91 mm x 112,78 mm L [Ø 0.39 in x 4.44 in L]
	WAN02RSP	02		tilt/swivel	2.2	RP-SMA plug/direct mount	Ø 9,91 mm x 112,78 mm L [Ø 0.39 in x 4.44 in L]
	WAN03RSP	03		flat	3.0	RP-SMA plug/adhesive mount	Ø 7,87 mm x 22,1 mm W x 4,57 mm D [Ø 0.31 in x 0.87 in W x 0.18 in D] 3 m [9 ft] cable
	WAN04RSP*	04** with a WAMM100RSP-005 base with 1,52 m [5 ft] of cable	05** with a WAMM100RSP-010 base with 3,05 m [10 ft] of cable	tilt/swivel	5.5	RP-SMA plug/direct mount	Ø 12,7 mm x 208,28 mm L [Ø 0.50 in x 8.20 in L]
	WAN05RSP*	06** with a WAMM100RSP-005 base with 1,52 m [5 ft] of cable	07** with a WAMM100RSP-010 base with 3,05 m [10 ft] of cable	tilt/swivel	9.0	RP-SMA plug/direct mount	Ø 12,7 mm x 384,05 mm L [Ø 0.50 in x 15.12 in L]
	WAN06RNJ*	08** with a WCA200RNPRSP-002 coax cable assembly 0,682 m [2 ft]	09** with a WCA200RNPRSP-010 coax cable assembly 3,05 m [10 ft]	straight	8.0	RP-N jack/bracket	Ø 33,5 mm x 427,9 mm L [Ø 1.32 in x 16.85 in L]
	WAN07RSP	11		straight	0.0	RP-SMA plug/direct mount	Ø 8,0 mm x 30 mm L [Ø 0.32 in x 1.18 in L]
	WAN09RSP	–		low profile mobile	3.0	RP-SMA plug/magnetic	Ø 76,2 mm x 115 mm L [Ø 3.0 in x 4.54 in L] 4,57 m [15 ft] cable
	WAN10RSP	–		straight	5.0	RP-SMA plug/magnetic	Ø 76,2 mm x 230,1 mm L [Ø 3.0 in x 9.06 in L] 1,52 m [5 ft] cable
	WAN11RSP*	–		low profile mobile dome	4.0	RP-SMA plug/thru-hole screw	Ø 39 mm x 42,4 mm L [Ø 1.54 in x 1.67 in L]

* Not allowed for use with Country Code “B” Limitless™ products

** See Tables 4 and 12 for accessory descriptions

Limitless™ Wireless Heavy-Duty Limit Switches

ACCESSORIES

Table 12. Cable and Coax Accessories











Photo	Part Number	Description
	WCA200RNPRSP-002	Limitless™ Series wireless cable assembly wth 200 Series cable, 2 ft length, reverse polarity N plug to reverse polarity SMA plug, use only with WAN06RNJ antenna
	WCA200RNPRSP-010	Limitless™ Series wireless cable assembly wth 200 Series cable, 10 ft length, reverse polarity N plug to reverse polarity SMA plug, use only with WAN06RNJ antenna
	WCA200RNJRSP-002	Limitless™ Series wireless cable assembly wth 200 Series cable, 2 ft length, reverse polarity SMA jack to reverse polarity SMA plug
	WCA200RNJRSP-005	Limitless™ Series wireless cable assembly wth 200 Series cable, 5 ft length, reverse polarity SMA jack to reverse polarity SMA plug
	WCA200RNJRSP-010	Limitless™ Series wireless cable assembly wth 200 Series cable, 10 ft length, reverse polarity SMA jack to reverse polarity SMA plug
	WCA200RNJRSP-015	Limitless™ Series wireless cable assembly wth 200 Series cable, 15 ft length, reverse polarity SMA jack to reverse polarity SMA plug
	WCA200RNJRSP-020	Limitless™ Series wireless cable assembly wth 200 Series cable, 20 ft length, reverse polarity SMA jack to reverse polarity SMA plug

Table 13. Base Accessories

Photo	Part Number	Description
	WAMM100RSP-005	Magnetic antenna base with 1,52 m [5 ft] of cable
	WAMM100RSP-010	Magnetic antenna base with 3,05 m [10 ft] of cable
	WPB1	WPMM Wireless panel mount reciever mounting bracket
	WPR1	WPMM panel mount retainer

WLS Series

This Honeywell datasheet supports the following Limitless™ WLS Series Listings

WLS1A00AA	WLS1A02AD	WLS1A00BA4M
WLS1A00AA1A	WLS1A02AE	WLS1A00BC
WLS1A00AA1B	WLS1A02AJ7M	WLS1A00BD
WLS1A00AA2A	WLS1A02AN	WLS1A00BE
WLS1A00AA2B	WLS1A02AN1A	WLS1A00BN
WLS1A00AA4M	WLS1A02AQB1	WLS1A00BQ-4P01
WLS1A00AA4N	WLS1A02AQB2	WLS1A00BQB1
WLS1A00AC	WLS1A02AQB3	WLS1A00BQB3
WLS1A00AD	WLS1A02AQB4	WLS1A00BQRS1
WLS1A00AE	WLS1A02AQRS1	WLS1A00BQRS2
WLS1A00AJ7A	WLS1A02AQRS2	WLS1A01BA1A
WLS1A00AJ7M	WLS1A11AA	WLS1A01BA1B
WLS1A00AJ7N	WLS1A11AA1A	WLS1A01BA2A
WLS1A00AN	WLS1A11AA1D	WLS1A01BA2B
WLS1A00AN1A	WLS1A11AA2A	WLS1A01BC
WLS1A00AQ-4P01	WLS1A11AA2A-3	WLS1A01BD
WLS1A00AQB1	WLS1A11AA2D	WLS1A01BN
WLS1A00AQB2	WLS1A11AA2J	WLS1A02BA1A
WLS1A00AQB3	WLS1A11AA2K	WLS1A02BA1B
WLS1A00AQB4	WLS1A11AA4N	WLS1A02BA2A
WLS1A00AQRS1	WLS1A11AC	WLS1A02BA2B
WLS1A00AQRS2	WLS1A11AD	WLS1A02BA4M
WLS1A01AA1A	WLS1A11AE	WLS1A02BC
WLS1A01AA1B	WLS1A11AJ7A	WLS1A02BD
WLS1A01AA1D	WLS1A11AN1A	WLS1A02BE
WLS1A01AA2A	WLS1A11AQ-4P01	WLS1A02BN
WLS1A01AA2B	WLS1A11AQB1	WLS1A02BQB1
WLS1A01AA2D	WLS1A11AQB2	WLS1A02BQB3
WLS1A01AA4M	WLS1A11AQB3	WLS1A02BQRS1
WLS1A01AA4N	WLS1A11AQB4	WLS1A02BQRS2
WLS1A01AC	WLS1A11AQ-P01	WLS1A11BA2K
WLS1A01AD	WLS1A11AQ-P02	WLS1A11BD
WLS1A01AN	WLS1A11AQRS1	WLS1A11BE
WLS1A02AA1A	WLS1A11AQRS2	WLS1A11BQ-4P01
WLS1A02AA1B	WLS1A11AV	WLS1A11BQB1
WLS1A02AA2A	WLS1A00BA	WLS1A11BQB3
WLS1A02AA2B	WLS1A00BA1A	WLS1A11BQ-P01
WLS1A02AA4M	WLS1A00BA1B	WLS1A11BQ-P02
WLS1A02AA4N	WLS1A00BA2A	WLS1A11BQRS1
WLS1A02AC	WLS1A00BA2B	WLS1A11BQRS2

ADDITIONAL INFORMATION

The following associated literature is available on the Honeywell web site at sensing.honeywell.com:

- Product installation instructions
- Product range guide
- Product brochure
- White Paper: Limitless™ Switches Offer Unlimited Benefits

WARNING

PERSONAL INJURY

DO NOT USE these products as safety or emergency stop devices or in any other application where failure of the product could result in personal injury.

Failure to comply with these instructions could result in death or serious injury.

WARNING

MISUSE OF DOCUMENTATION

- The information presented in this product sheet is for reference only. Do not use this document as a product installation guide.
- Complete installation, operation, and maintenance information is provided in the instructions supplied with each product.

Failure to comply with these instructions could result in death or serious injury.

WARRANTY/REMEDY

Honeywell warrants goods of its manufacture as being free of defective materials and faulty workmanship. Honeywell's standard product warranty applies unless agreed to otherwise by Honeywell in writing; please refer to your order acknowledgement or consult your local sales office for specific warranty details. If warranted goods are returned to Honeywell during the period of coverage, Honeywell will repair or replace, at its option, without charge those items it finds defective. **The foregoing is buyer's sole remedy and is in lieu of all other warranties, expressed or implied, including those of merchantability and fitness for a particular purpose. In no event shall Honeywell be liable for consequential, special, or indirect damages.**

While we provide application assistance personally, through our literature and the Honeywell website, it is up to the customer to determine the suitability of the product in the application.

Specifications may change without notice. The information we supply is believed to be accurate and reliable as of this printing. However, we assume no responsibility for its use.

Find out more

Honeywell serves its customers through a worldwide network of sales offices, representatives and distributors. For application assistance, current specifications, pricing or name of the nearest Authorized Distributor, contact your local sales office.

To learn more about Honeywell's sensing and control products, call **+1-815-235-6847** or **1-800-537-6945**, visit **sensing.honeywell.com**, or e-mail inquiries to **info.sc@honeywell.com**

Sensing and Control
Honeywell
1985 Douglas Drive North
Golden Valley, MN 55422
honeywell.com

The Honeywell logo is displayed in a bold, red, sans-serif font.