



Chipsmall Limited consists of a professional team with an average of over 10 year of expertise in the distribution of electronic components. Based in Hongkong, we have already established firm and mutual-benefit business relationships with customers from,Europe,America and south Asia,supplying obsolete and hard-to-find components to meet their specific needs.

With the principle of “Quality Parts,Customers Priority,Honest Operation,and Considerate Service”,our business mainly focus on the distribution of electronic components. Line cards we deal with include Microchip,ALPS,ROHM,Xilinx,Pulse,ON,Everlight and Freescale. Main products comprise IC,Modules,Potentiometer,IC Socket,Relay,Connector.Our parts cover such applications as commercial,industrial, and automotives areas.

We are looking forward to setting up business relationship with you and hope to provide you with the best service and solution. Let us make a better world for our industry!



Contact us

Tel: +86-755-8981 8866 Fax: +86-755-8427 6832

Email & Skype: info@chipsmall.com Web: www.chipsmall.com

Address: A1208, Overseas Decoration Building, #122 Zhenhua RD., Futian, Shenzhen, China



THIS COPY IS PROVIDED ON A RESTRICTED BASIS AND IS NOT TO BE USED IN ANY WAY DETRIMENTAL TO THE INTERESTS OF PANDUIT CORP.

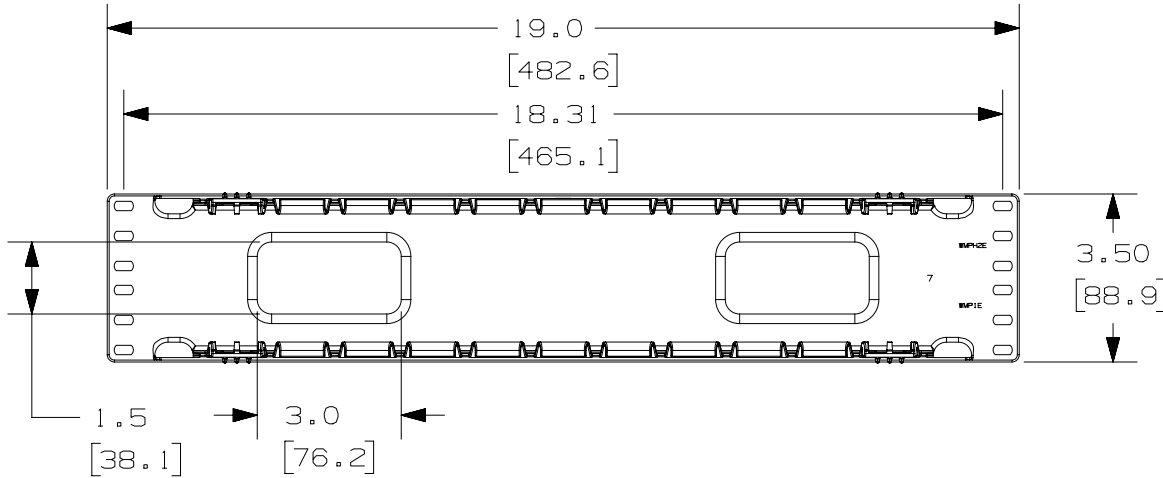

PANDUIT P/N	WEIGHT
WMPH2E	2.6 LBS/EACH 1179 g/EACH

- NOTES:
- DESIGNED FOR MOUNTING ON 19" EIA RACKS.
 - COMPONENTS:
 - 1- MANAGER
 - 1- 17" REAR DUAL HINGED COVER
 - 1- 19.375" FRONT DUAL HINGED COVER
 - 4- #12-24 x 2" SCREWS
 - 2- BEND RADIUS CLIPS
 - DIMENSIONS IN PARENTHESES ARE METRIC.

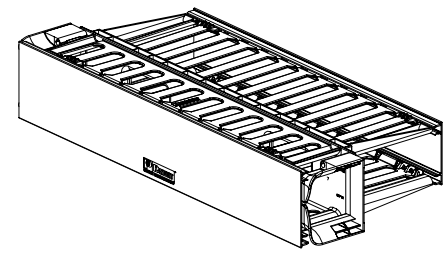
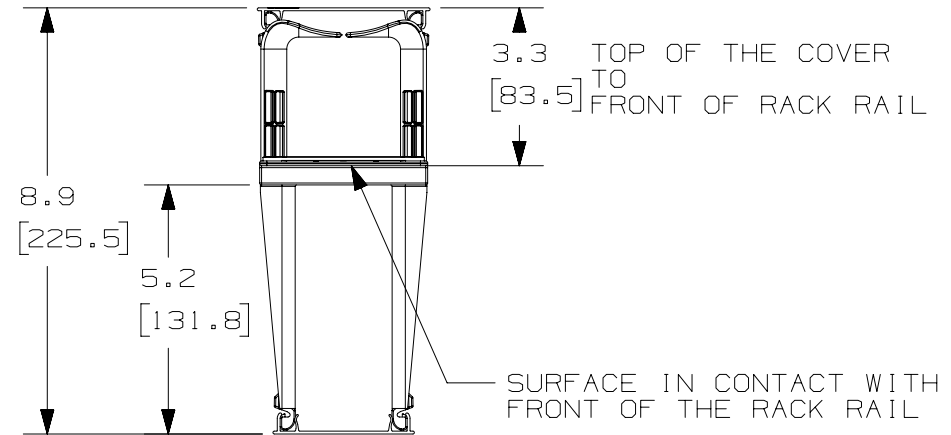
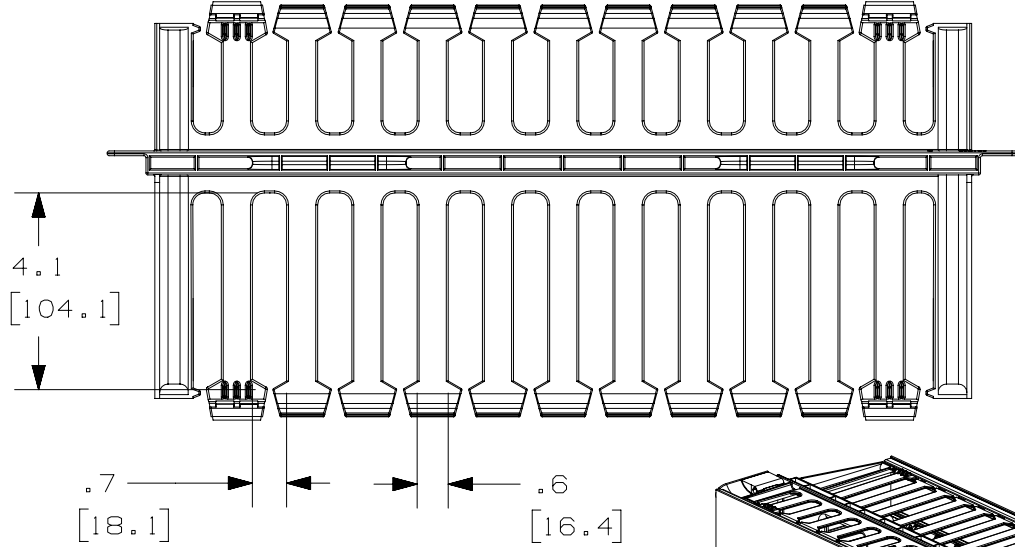

TITLE		WMPH2E HORIZONTAL MANAGER						
CUSTOMER DRAWING								
ITEM REVISION NAME	V10101WH/08	PANDUIT	MATERIAL: ABS					
DATASET FILE NAME	V10101WH_DC/08A							
UNLESS OTHERWISE SPECIFIED, DIMENSIONAL TOLERANCES ARE: IN (mm)		DRAWING NUMBER: 10101-23						
.X ±	.XXX ±	THIRD ANGLE PROJECTION						
.XX ±	ANGLES ±							
DRAWN BY	DATE	CHK	SCALE					
JDWE	12-17-02	MECA	NONE					
REV	DATE	BY	CHK	APR	DESCRIPTION	ECN	SHT 1 OF 1	SIZE
08A	3-26-15	TWV	MACA	KRKE	BOM ADJUSTMENT; REVISED NOTES.	10101-23		A
07D	4-22-13	BAME	RYB	CMK	REVISED AND REDRAWN; ALL PREVIOUS REVS OMITTED REVISED TITLE BLOCK	10101-23		

D10100DA/15