



Chipsmall Limited consists of a professional team with an average of over 10 year of expertise in the distribution of electronic components. Based in Hongkong, we have already established firm and mutual-benefit business relationships with customers from,Europe,America and south Asia,supplying obsolete and hard-to-find components to meet their specific needs.

With the principle of “Quality Parts,Customers Priority,Honest Operation,and Considerate Service”,our business mainly focus on the distribution of electronic components. Line cards we deal with include Microchip,ALPS,ROHM,Xilinx,Pulse,ON,Everlight and Freescale. Main products comprise IC,Modules,Potentiometer,IC Socket,Relay,Connector.Our parts cover such applications as commercial,industrial, and automotives areas.

We are looking forward to setting up business relationship with you and hope to provide you with the best service and solution. Let us make a better world for our industry!



Contact us

Tel: +86-755-8981 8866 Fax: +86-755-8427 6832

Email & Skype: info@chipsmall.com Web: www.chipsmall.com

Address: A1208, Overseas Decoration Building, #122 Zhenhua RD., Futian, Shenzhen, China





PRODUCT SPECIFICATION

SPEC. No : W-1101-275

Attn: _____

DATE : _____

CUSTOMER PRODUCT NAME:
TDK PRODUCT NAME: WR202010-18M8-SM
APPROVED BY:
CUSTOMER COMMENT:
REMARK: Please sign back specification after customer conformation until 2weeks. If customer can't sign back specification, customer should be approved TDK specification. Or TDK receive customer PO. TDK will deem that customer recognises TDK specification.

TDK Corporation

Head Office Address:

3-9-1, Shibaura, Minato-ku, Tokyo

108-0023 , Japan

SALES

MANAGER	SALES

ENGINEERING

APPROVED	CHECKED	ISSUED

Sales Office _____

Sales Tel. _____

PRODUCT	
---------	--

REVISED HISTORY

CUSTOMER PRODUCT NAME: _____

TDK PRODUCT NAME: _____

WR202010-18M8-SM

NO.	REV.	REVISED CONTENT	REVISED REASON	DATE
1	0	To establish specification.		2016/8/1

PRODUCT SPECIFICATION

TDK PRODUCT NAME: WR202010-18M8-SM	SPEC. NO. W-1101-275	CUSTOMER PRODUCT NAME:
--	-------------------------	------------------------

(0) Part No. definition

Weight: 0.55 g (Typ.)

WR202010-18M8-SM

WR : Wireless charging Rx, 18 : Wire turn number,

202010 : Size (XYT), M8 : Ferrite sheet material

SM : Specific number for Customer

(1) Mechanical Dimension (Unit: mm)

Top View

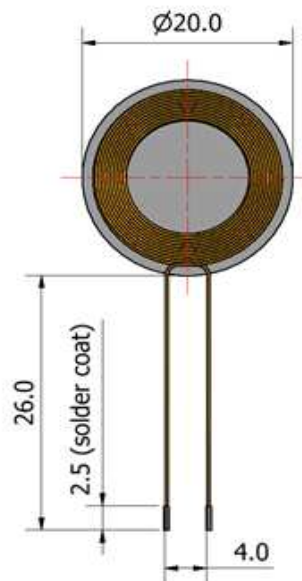

Bottom View

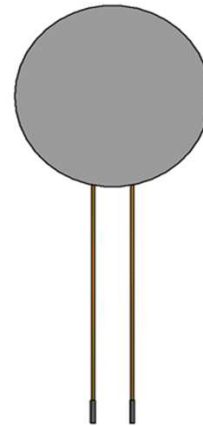

Side View



(2) Remarks

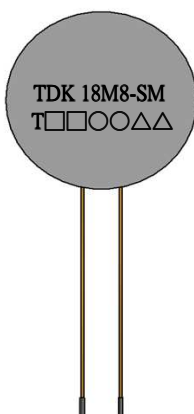

Marking Content:

a. Product name : 18 M 8 - SM

① ② ③ ④

① Air coil turn

② Sheet Material name

③ Customer name

④ Version number

b. Lot No.: T 12 34 56

① ② ③

① Year: 2016 : 16 , 2017 : 17

② Month: 01...12

③ Day : 01,...31.

PRODUCT SPECIFICATION

TDK PRODUCT NAME: WR202010-18M8-SM	SPEC. NO. W-1101-275	CUSTOMER PRODUCT NAME:
--	-------------------------	------------------------

(3) Air coil specification

No.	Wire Type:	Wire spec.	Turns	Layer
1	3 Lock	φ0.25	18Ts	2

(4-1) Electrical Characteristics

Items	Parameter	Specification	Test Instrument
1	Inductance	10.7 μ H \pm 5%	Agilent E4980A LCR METER or EQUIVALENT (@1.0MHz 1.0 Vrms)
2	Rs	2.96 Ω \pm 10%	Agilent E4980A LCR METER or EQUIVALENT (@1.0MHz 1.0 Vrms)
3	Rdc (Reference)	0.35 Ω Typ.	CHEN HWA 502A OHM METER or EQUIVALENT

(4-2) Temperature Characteristics

No.	Parameter	Specification
1	Operating Temperature	-30~70°C
2	Storage Temperature	-40~85°C

PRODUCT SPECIFICATION

TDK PRODUCT NAME:

WR202010-18M8-SM

SPEC. NO.

W-1101-275

CUSTOMER PRODUCT NAME:

(5) Reliability Conditions

NO.	Parameter	Conditions
1	Low Temperature (Storage)	(1) Temperature : $-40\pm 2^{\circ}\text{C}$ (2) Time : 240Hrs
2	High Temperature (Storage)	(1) Temperature : $+85\pm 2^{\circ}\text{C}$ (2) Time : 240Hrs
3	Thermal Shock (Storage)	(1) Temperature : $-40\pm 5^{\circ}\text{C} / 30\text{min} \sim +85\pm 5^{\circ}\text{C} / 30\text{min}$ (2) Ambient Time : 5min (3) Times : 200cycles
4	Vibration (sinusoidal)	Unpacked: (1)frequency:10~350Hz sweep octave wave(10~350~10 for 1 min) (2)Amplitude:1.5mm(p-p) or 10G (3)Direction:X.Y.Z. direction (4)Time:X.Y.Z each 2 hours.
5	Shock Test	Fixed within the jig (1) Acceleration : 1000m / s ² (2) Pulse width : 6 msec (3)Direction:X.Y.Z. direction (4) Frequency of shock : 3 times each , (Total 18 times)
6	Free fall	(1) Height : 160cm to the concrete floor (fixture weight : 160g) (2) Direction : 6 directions (3) Times : 3 times / direction
7	Packaging test	(1) Drop the sample packaged in a carton box. (2) Height : 100 cm (3) Direction : 1corner,3 edges, 6 faces (4) Drop time : 10 times
8	Temp. / Humidity (storage)	(1)Temperature : $+60\pm 2^{\circ}\text{C}$ (2)Humidity: 90% R.H. (3)Time: 240Hrs

PRODUCT SPECIFICATION

TDK PRODUCT NAME:

WR202010-18M8-SM

SPEC. NO.

W-1101-275

CUSTOMER PRODUCT NAME:

(6) Construction

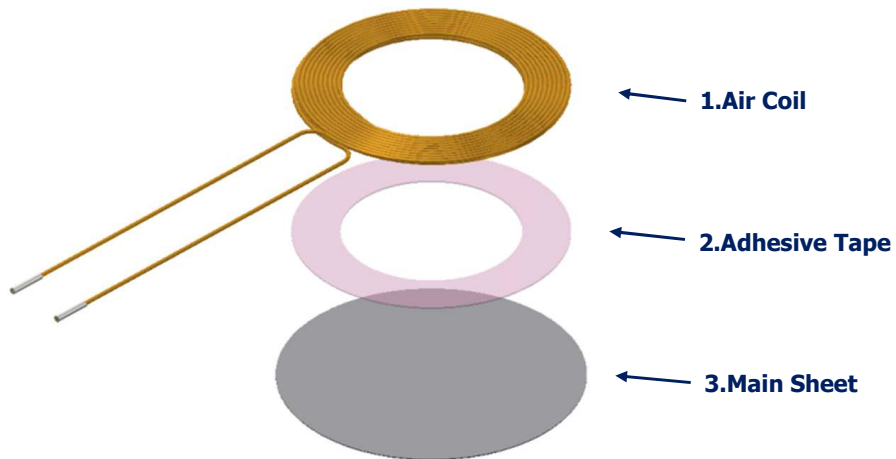

(7) Material List

No.	Material Name
1	Air coil
2	Adhesive Tape
3	Main Sheet
4	INK

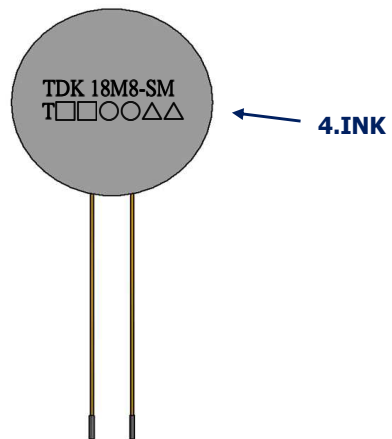

PRODUCT SPECIFICATION

TDK PRODUCT NAME:

WR202010-18M8-SM

SPEC. NO.

W-1101-275

CUSTOMER PRODUCT NAME:

(8) Packing

1. To stack the the Trays onto 6 Layers. :

- PS tray dimension: 329*326*9.5mm

- 45 Pcs / per PET tray

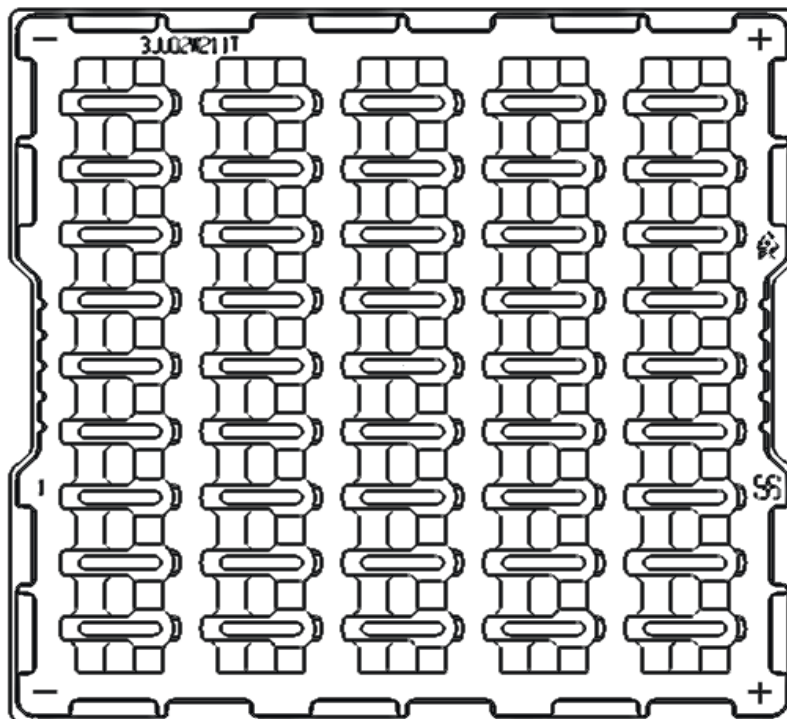

Total : 45pcs

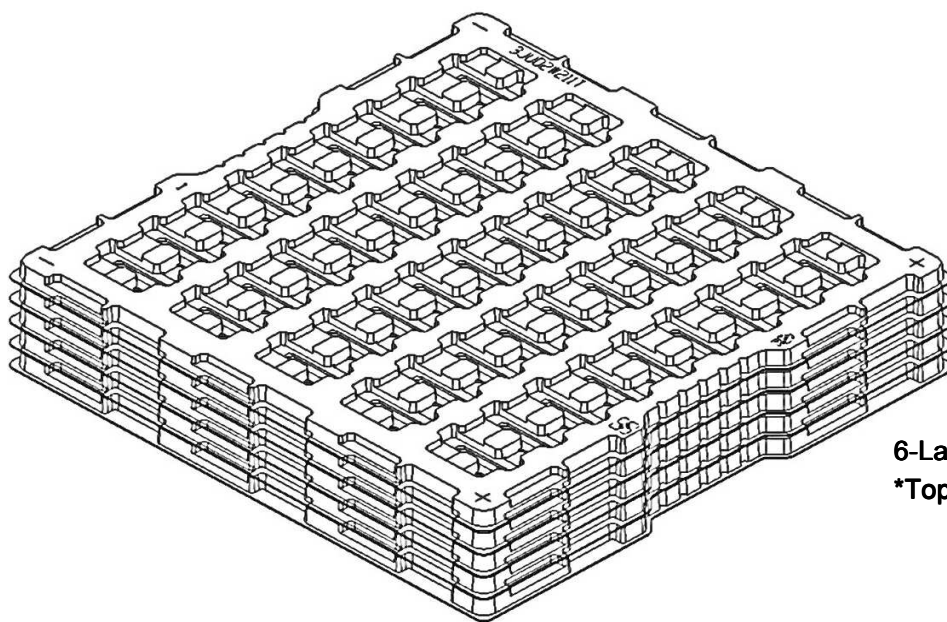

6-Layers
*Top side is empty.

Total : 45x5=225pcs

PRODUCT SPECIFICATION

TDK PRODUCT NAME:

WR202010-18M8-SM

SPEC. NO.

W-1101-275

CUSTOMER PRODUCT NAME:

2. To put 6 Trays of products into the small carton and affixing the out-going label on the outside .

- 6 PS Trays / per small carton (One PS tray of the top side is empty in the small carton)
- In carton label should be located on the lower right and lower left hand corner of top face
- Small carton dimension: 331x337x33mm
- Label dimension: 100*42 mm

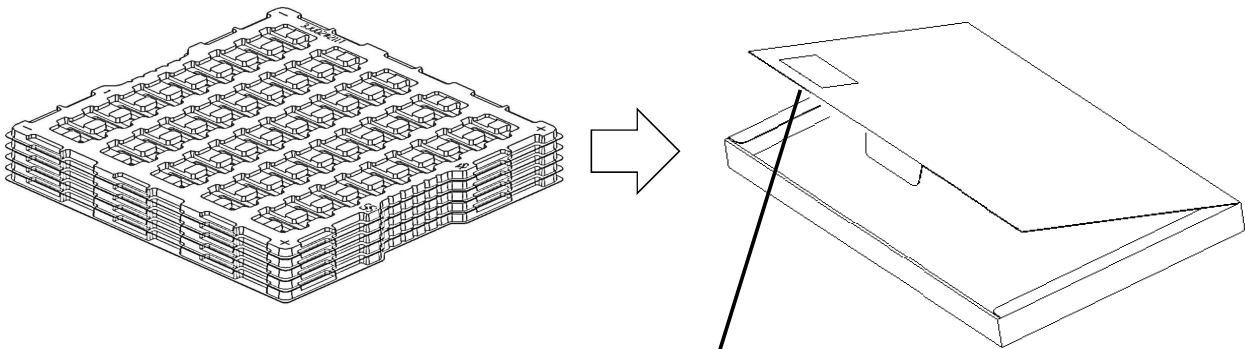

Product package label

PRODUCT SPECIFICATION

TDK PRODUCT NAME: WR202010-18M8-SM	SPEC. NO. W-1101-275	CUSTOMER PRODUCT NAME:
--	-------------------------	------------------------

3. To put 3 small cartons into the outer carton .
- Outer carton dimension: 352x350x137mm
 - Total quantity : 675 Pcs

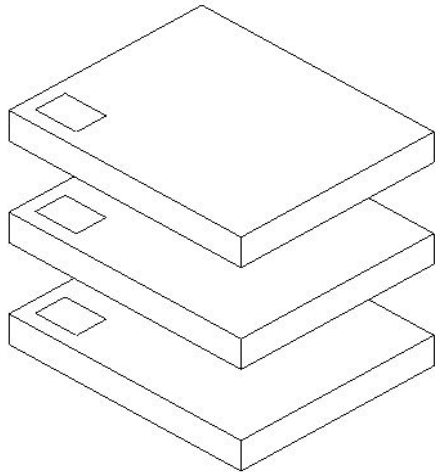

3 small cartons

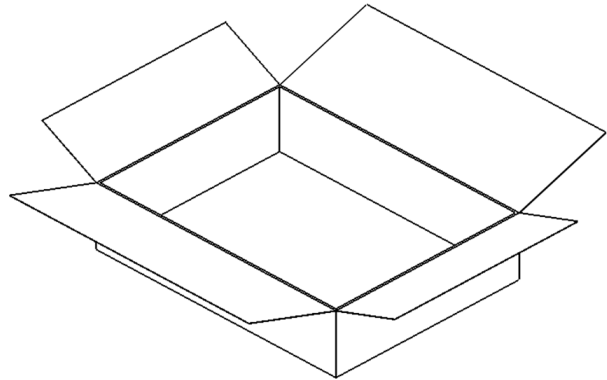

Outer carton

4. Packing.

- To pack the carton by scotch tape and affix out-going label (outside) on it outside.
- The Inspection data in the outer carton , there would be a signet mark on it outside.
- In carton label should be located on the lower left hand corner of greatest face.
- Receiving label dimension: 210*100 mm

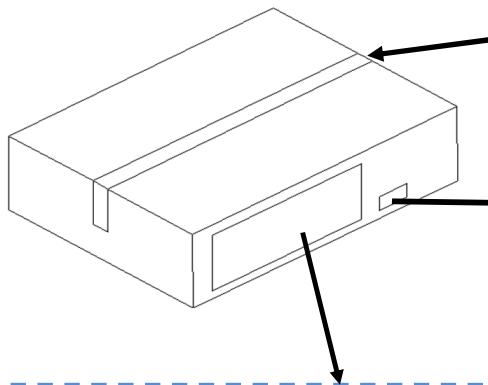

signet mark of Inspection data

(3S) TTTW+WL11 K06002001 01 400000360 		CUSTOMER:	
(6S) C/NO:1 		CUST. PART NO(P): 	
BOX COUNT 001/009		TDK ITEM CODE(6P): TTXDFxxxx TWN 	
SHIPPING MARK ROHS		P/O NO.(G): TTTT-S123456789 	
SAMPLE		LOT NO.(1T): WL12345678	
		DATE: 08.01.2016	
Location		QTY(Q): 675 	
		TDK ITEM (1P): WR202010-18M8-SM 	
MADE IN TAIWAN		(WR202010-18M8-SM)	
		SUB P/O NO.(6P): 4500059424 	
C/NO:1		TDK SPEC.	
WAREHOUSE (GT) NW 5.5 GW 6.50		TTX TAIWAN CORPORATION YANGMEI, TAIWAN 9 	
		TTXDF10151	

Receiving label format



REMINDERS

Please read this before using the product.



REMINDERS

1. We may modify products or discontinue production of a product listed in this catalog without prior notification.
2. We provide "Delivery Specification" that explain precautions for the specifications and safety of each product listed in this catalog.
We strongly recommend that you exchange these delivery specifications with customers that use one of these products.
3. If you plan to export a product listed in this catalog, keep in mind that it may be a restricted item according to the "Foreign Exchange and Foreign Trade Control Law". In such cases, it is necessary to acquire export permission in harmony with this law.
4. Any reproduction or transferring of the contents of this catalog is prohibited without prior permission from our company.
5. We are not responsible for problems that occur related to the intellectual property rights or other rights of our company or a third party when you use a product listed in this catalog. We do not grant license of these rights.
6. This catalog only applies to products purchased through our company or one of our company's official agencies. This catalog does not apply to products that are purchased through other third parties.
7. The products listed on this catalog are intended for use in general electronic equipment (AV equipment, telecommunications equipment, home appliances, amusement equipment, computer equipment, personal equipment, office equipment, measurement equipment, industrial robots) under a normal operation and use condition.

The products are not designed or warranted to meet the requirements of the applications listed below, whose performance and/or quality require a more stringent level of safety or reliability, or whose failure, malfunction or trouble could cause serious damage to society, person or property.

If you intend to use the products in the applications listed below or if you have special requirements exceeding the range or conditions set forth in the each catalog, please contact us.

- (1) Aerospace/Aviation equipment
- (2) Transportation equipment (cars, electric trains, ships, etc.)
- (3) Medical equipment
- (4) Power-generation control equipment
- (5) Atomic energy-related equipment
- (6) Seabed equipment
- (7) Transportation control equipment
- (8) Public information-processing equipment
- (9) Military equipment
- (10) Electric heating apparatus, burning equipment
- (11) Disaster prevention/crime prevention equipment
- (12) Safety equipment
- (13) Other applications that are not considered general-purpose applications

When designing your equipment even for general-purpose applications, you are kindly requested to take into consideration securing protection circuit/device or providing backup circuits in your equipment.