



Chipsmall Limited consists of a professional team with an average of over 10 year of expertise in the distribution of electronic components. Based in Hongkong, we have already established firm and mutual-benefit business relationships with customers from,Europe,America and south Asia,supplying obsolete and hard-to-find components to meet their specific needs.

With the principle of “Quality Parts,Customers Priority,Honest Operation,and Considerate Service”,our business mainly focus on the distribution of electronic components. Line cards we deal with include Microchip,ALPS,ROHM,Xilinx,Pulse,ON,Everlight and Freescale. Main products comprise IC,Modules,Potentiometer,IC Socket,Relay,Connector.Our parts cover such applications as commercial,industrial, and automotives areas.

We are looking forward to setting up business relationship with you and hope to provide you with the best service and solution. Let us make a better world for our industry!



## Contact us

Tel: +86-755-8981 8866 Fax: +86-755-8427 6832

Email & Skype: info@chipsmall.com Web: www.chipsmall.com

Address: A1208, Overseas Decoration Building, #122 Zhenhua RD., Futian, Shenzhen, China



## RN52 Bluetooth Audio Module

### Features:

- Fully qualified Bluetooth® version 3.0 module, fully compatible with Bluetooth version 2.1+EDR, 1.2, and 1.1
- Software configurable through commands over UART console interface
- Dedicated GPIO pins enable MCUs to access control and status functions efficiently
- Postage-stamp-sized form factor, 13.5 x 26.0 x 2.7 mm
- Embedded Bluetooth stack profiles: A2DP, AVRCP, HFP/HSP, and SPP
- Dual-channel, differential audio input and output for highest quality audio
- Supports iAP profile to discover iOS devices and apps (requires a special firmware build)
- Integrated amplifier for driving 16 Ω speakers
- UART (SPP) data connection interfaces
- External audio CODECs supported via S/PDIF and I<sup>2</sup>S interface
- Castellated SMT pads for easy and reliable PCB mounting
- Environmentally friendly, RoHS compliant
- Certifications: FCC, ICS, CE
- Bluetooth SIG certified



### RN52 Block Diagram:

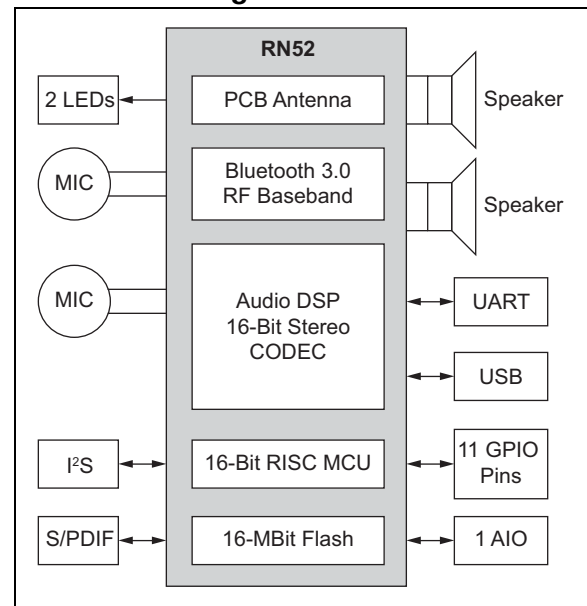

### Applications:

- High-quality, 2-channel audio streaming
- Wireless stereo headsets
- Automotive hands free audio
- Wireless audio docking station for smartphones
- Wireless speakers
- Intercom push-to-talk audio connection
- Remote control for media player
- Medical devices
- Computer accessories

## 1.0 DEVICE OVERVIEW

Roving Network’s RN52 Bluetooth audio module provides a highly integrated solution for delivering high-quality stereo audio in a small form factor. It combines a class 2 Bluetooth radio with an embedded DSP processor. The module is programmed and controlled with a simple ASCII command language.

The RN52 module complies with Bluetooth specification version 3.0. It integrates RF, a baseband controller, etc., making it a complete Bluetooth subsystem. The RN52 supports a variety of profiles including HSP/HFP, A2DP, AVRCP, SPP, and iAP. It provides a UART interface, several user programmable I/O pins, stereo speaker outputs, microphone inputs, and a USB port.

Table 1-1 provides the general specifications for the module. Table 1-2 and Table 1-3 provide the module’s weight, dimensions, and electrical characteristics.

**TABLE 1-1: GENERAL SPECIFICATIONS**

Specification	Description
Standard	Bluetooth 3.0, class 2
Frequency Band	2.4 ~ 2.48 GHz
Modulation Method	GFSK, PI/4-DQPSK, 8 DPSK
Maximum Data Rate	3 Mbps
RF Input Impedance	50 ohms
Interface	UART, GPIO, AIO, USB, SPI, speaker, microphone
Operation Range	10 meters (33 feet)
Sensitivity	-85 dBm at 0.1 % BER
RF TX Power	4 dBm

**TABLE 1-2: WEIGHT & DIMENSIONS**

Specification	Description
Dimensions	26.0 mm x 13.5 mm x 2.7 mm
Weight	1.2 g

**TABLE 1-3: ELECTRICAL CHARACTERISTICS**

Specification	Description
Supply Voltage	3.0 ~ 3.6 V DC
Working current	Depends on profiles, 30 mA typical
Standby current (disconnected)	< 0.5 mA
Temperature	-40°C to +85°C
ESD	JESD22-A224 class 0 product
Humidity	10% ~ 90% non-condensing

Figure 1-1 shows the module’s dimensions and Figure 1-2 shows recommended landing pattern and layout.



**FIGURE 1-1: MODULE DIMENSIONS**

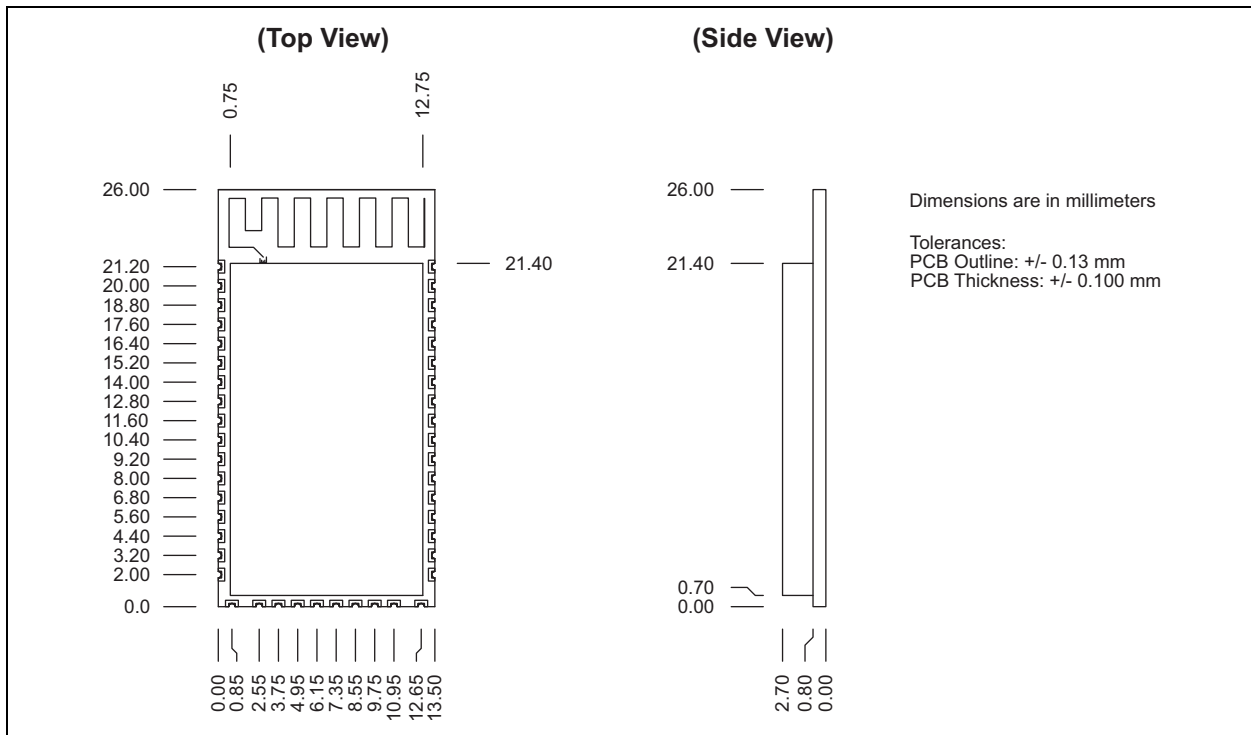

**FIGURE 1-2: RECOMMENDED PCB FOOTPRINT**

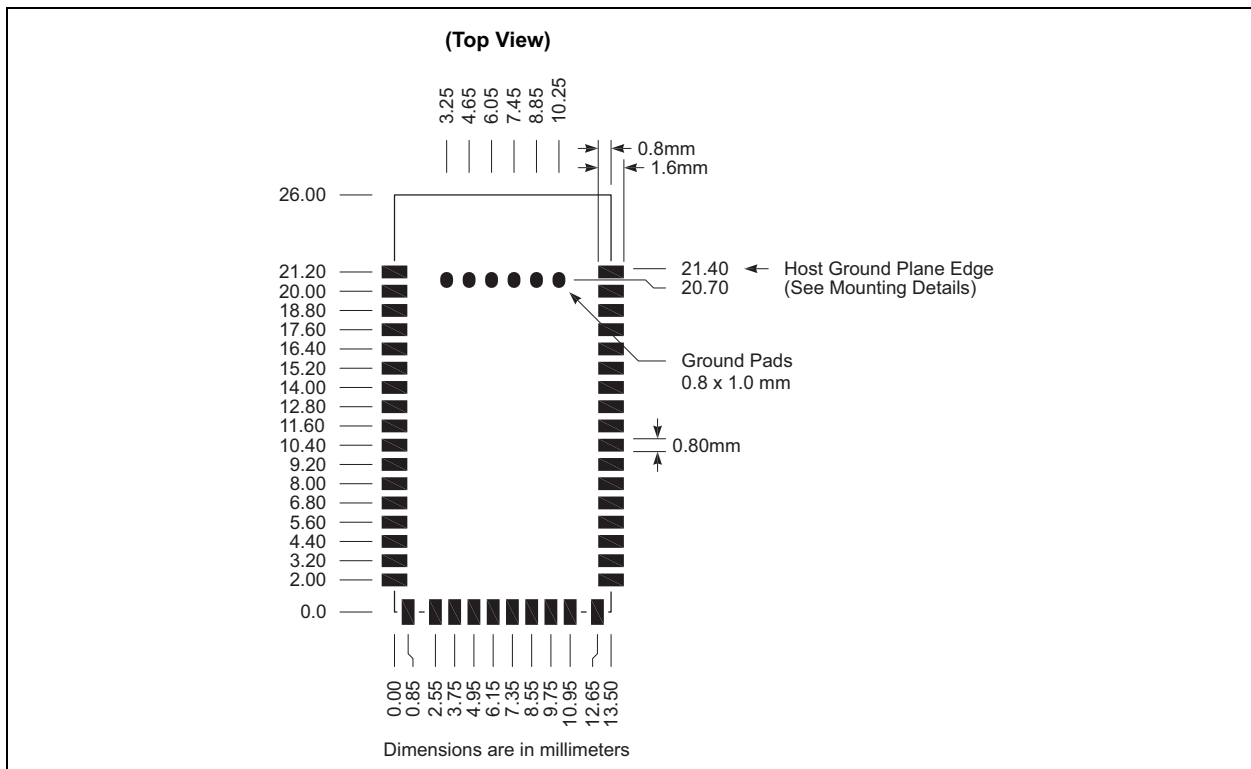
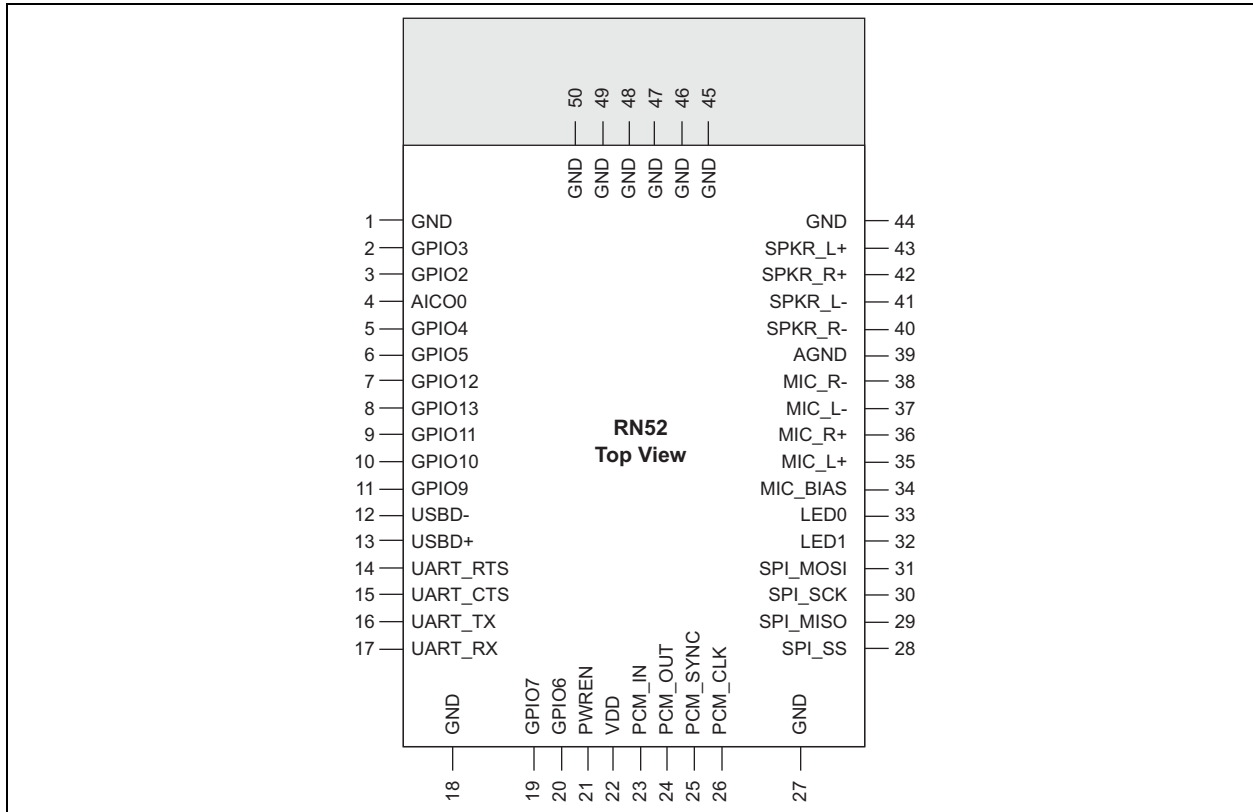

Figure 1-3 shows the pinout and Table 1-4 describes the module's pins.

**FIGURE 1-3: PIN DIAGRAM**



**TABLE 1-4: PIN DESCRIPTION (PART 1 OF 3) Note 1**

Pin	Symbol	I/O Type	Description	Direction	Default
1	GND	Ground.	Ground.		
2	GPIO3	Bidirectional with programmable strength internal pull-up/down.	This pin enters device firmware update (DFU) mode at bootup if a USB device powers $V_{BUS}$ . GPIO3 requires 47 k $\Omega$ to ground and 22 k $\Omega$ to the USB $V_{BUS}$ signal if the USB $V_{BUS}$ is supplying power to the main board.	Input	Low
3	GPIO2	Bidirectional with programmable strength internal pull-up/down.	Reserved, event register. Toggles from high to low for 100 ms to indicate that the module's state has changed. A microcontroller can enter command mode and poll the state register using the Q action command.	Output	High
4	AIO0	Bidirectional.	Analog programmable input/output line.	I/O	
5	GPIO4	Bidirectional with programmable strength internal pull-up/down.	Factory reset mode. To reset the module to the factory defaults, GPIO4 should be high on power-up and then toggle low, high, low, high with a 1 second wait between the transitions.	Input	Low

**TABLE 1-4: PIN DESCRIPTION (PART 2 OF 3) Note 1**

Pin	Symbol	I/O Type	Description	Direction	Default
6	GPIO5	Bidirectional with programmable strength internal pull-up/down.	Programmable I/O.	I/O	High
7	GPIO12	Bidirectional with programmable strength internal pull-up/down.	Programmable I/O.	I/O	High
8	GPIO13	Bidirectional with programmable strength internal pull-up/down.	Programmable I/O.	I/O	High
9	GPIO11	Bidirectional with programmable strength internal pull-up/down.	Programmable I/O.	I/O	High
10	GPIO10	Bidirectional with programmable strength internal pull-up/down.	Programmable I/O.	I/O	High
11	GPIO9	Bidirectional with programmable strength internal pull-up/down.	When you drive this signal low, the module's UART goes into command mode. If this signal floats high, the UART is in data mode. Reserved. Not available for use at runtime.	Input	High
12	USBD-	Bidirectional.	USB data minus.	I/O	
13	USBD+	Bidirectional.	USB data plus with selectable internal 1.5-Kohm pull-up resistor.	I/O	
14	UART_RTS	CMOS output, tri-state, with weak internal pull-up.	UART request to send active low.	Output	
15	UART_CTS	CMOS input with weak internal pull-down.	UART clear to send active low.	Input	
16	UART_TX	CMOS output, tri-state, with weak internal pull-up.	UART data output.	Output	
17	UART_RX	CMOS input with weak internal pull-down.	UART data input.	Input	
18	GND	Ground.	Ground.		
19	GPIO7	Bidirectional with programmable strength internal pull-up/down.	Driving this pin low sets the UART baud rate to 9,600. By default the pin is high with a baud rate of 115,200.	I/O	High
20	GPIO6	Bidirectional with programmable strength internal pull-up/down.	Programmable I/O.	I/O	High
21	PWREN	Analog.	Pull high to power up RN52.		
22	VDD	3.3-V power input.	3.3v power input.		
23	PCM_IN	CMOS input, with weak internal pull down.	Synchronous data input, configurable for SPDIF_IN or SD_IN (I <sup>2</sup> S).	Input	
24	PCM_OUT	CMOS input, with weak internal pull down.	Synchronous data input, configurable for SPDIF_OUT or SD_OUT (I <sup>2</sup> S).	Input	
25	PCM_SYNC	Bidirectional with weak internal pull down.	Synchronous data sync; WS (I <sup>2</sup> S).	I/O	
26	PCM_CLK	CMOS input, with weak internal pull down.	Synchronous data clock; SCK (I <sup>2</sup> S).	Input	

**TABLE 1-4: PIN DESCRIPTION (PART 3 OF 3) [Note 1](#)**

Pin	Symbol	I/O Type	Description	Direction	Default
27	GND	Ground.	Ground.		
28	SPI_SS	CMOS input with weak internal pull-up.	Chip select for Synchronous Serial Interface active low.	Input	
29	SPI_MISO	CMOS output, tri-state, with weak internal pull-down.	Serial Peripheral Interface (SPI) output.	Output	
30	SPI_CLK	Input with weak internal pull-down.	SPI clock.	Input	
31	SPI_MOSI	CMOS input, with weak internal pull-down.	SPI input.	Input	
32	LED1	Open drain output.	Drives an LED. For the RN-52-EK board, this signal drives the red LED.	Output	
33	LED0	Open drain output.	Drives an LED. For the RN-52-EK board, this signal drives the blue LED.	Output	
34	MIC_BIAS	Analog.	Microphone bias.	Output	
35	MIC_L+	Analog.	Microphone input positive, left.	Output	
36	MIC_R+	Analog.	Microphone input positive, right.	Output	
37	MIC_L-	Analog.	Microphone input negative, left.	Output	
38	MIC_R-	Analog.	Microphone input negative, right.	Output	
39	AGND	Analog.	Ground connection for audio.		
40	SPK_R-	Analog.	Speaker output negative (right side).	Output	
41	SPK_L-	Analog.	Speaker output negative (left side).	Output	
42	SPK_R+	Analog.	Speaker output positive (right side).	Output	
43	SPK_L+	Analog.	Speaker output positive (left side).	Output	
44	GND	Ground.	Ground.		
45	GND	Ground.	RF ground.		
46	GND	Ground.	RF ground.		
47	GND	Ground.	RF ground.		
48	GND	Ground.	RF ground.		
49	GND	Ground.	RF ground.		
50	GND	Ground.	RF ground.		

**Note 1:** All GPIO pins default to input with weak pull-down.

## 1.1 Audio Interface Circuit Description

The RN52 audio interface circuit consists of:

- Stereo audio CODEC
- Dual audio inputs and dual outputs
- Configurable S/PDIF and I<sup>2</sup>S interface

The audio input circuitry has a dual audio input that can be configured as single-ended or fully differential and programmed for microphone or line input. It has an analog and digital programmable gain stage so that it can be optimized for different microphones. See [Figure 1-4](#).

### 1.1.1 STEREO AUDIO CODEC INTERFACE

The stereo audio CODEC interface has stereo and mono analog input/output for voice and audio bands. It supports the IEC-60958 stereo digital audio bus standards, e.g., S/PDIF and AES3/EBU.

The built-in CODEC uses a fully differential architecture in the analog signal path, which results in low noise sensitivity and good power supply rejection while effectively doubling the signal amplitude. It operates from a 1.5 V single power supply and uses a minimum of external components. See [Figure 1-5](#).

**FIGURE 1-4: RN52 AUDIO INTERFACE BLOCK DIAGRAM**

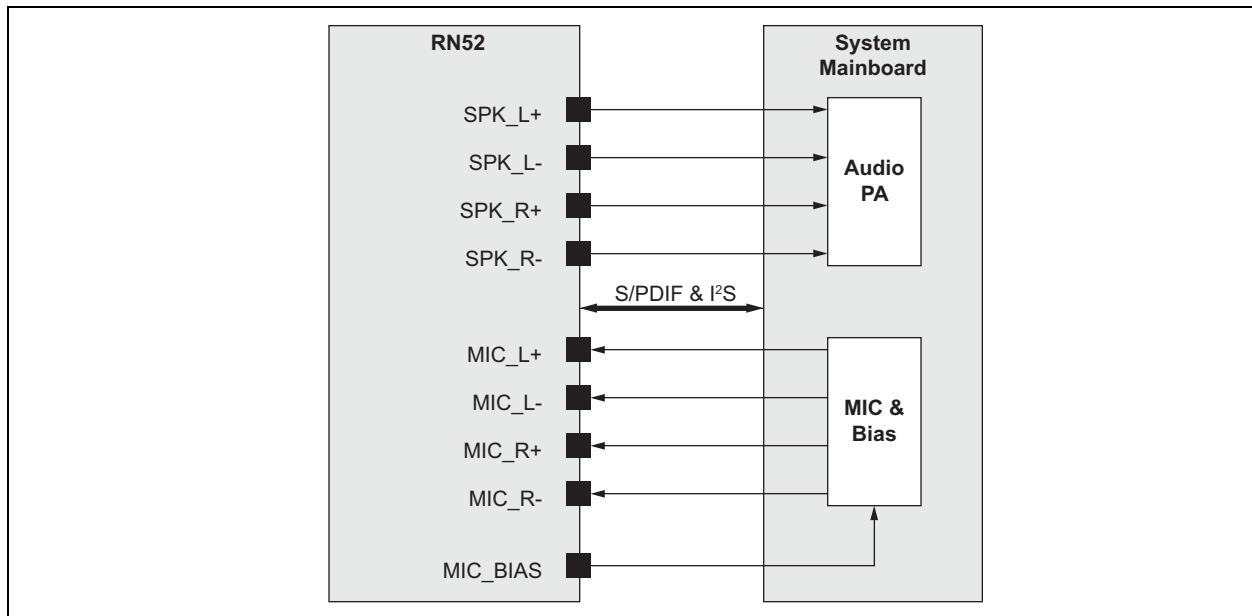

**FIGURE 1-5: STEREO CODEC AUDIO INPUT/OUTPUT STAGES**

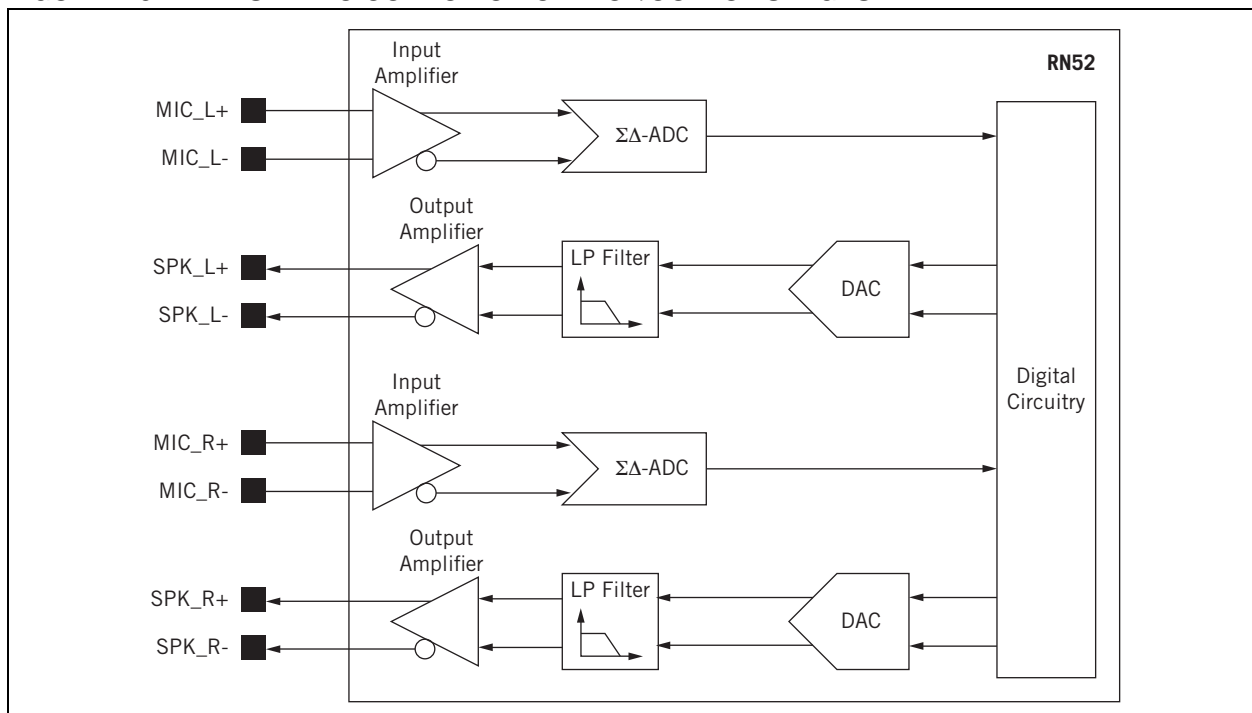



### 1.1.2 ANALOG-TO-DIGITAL CONVERTER (ADC)

The ADC consists of two second-order sigma delta (SD) converters, resulting in two separate channels with identical functionality. Each ADC supports the following sample rates:

- 8 kHz
- 11.025 kHz
- 16 kHz

- 22.05 kHz
- 24 kHz
- 32 kHz
- 44.1 kHz

The ADC analog amplifier is a two-stage amplifier. The first stage selects the correct gain for either microphone or line input. See [Figure 1-6](#).

**FIGURE 1-6: ADC ANALOG AMPLIFIER BLOCK DIAGRAM**

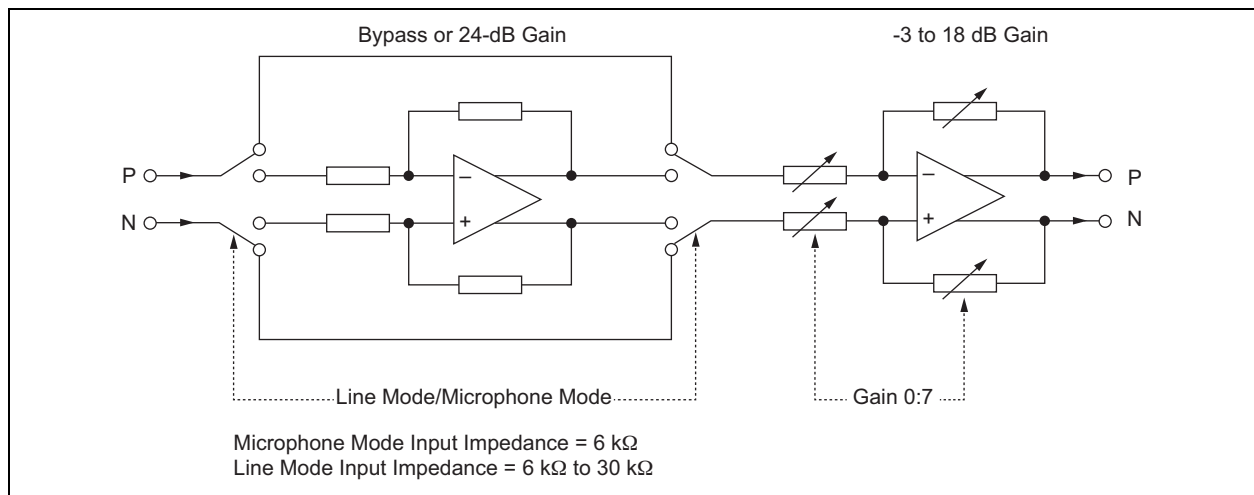

### 1.1.3 DIGITAL-TO-ANALOG CONVERTER (DAC)

The DAC consists of two third-order SD converters, resulting in two separate channels with identical functionality. Each DAC supports the following sample rates:

- 8 kHz
- 11.025 kHz
- 16 kHz
- 22.05 kHz
- 24 kHz
- 32 kHz
- 44.1 kHz

### 1.1.4 MICROPHONE INPUT

The RN52 audio input is intended for use from 1  $\mu$ A at 94 dB SPL to about 10  $\mu$ A at 94 dB SPL, which requires microphones with sensitivity between -40 and -60 dBV. MIC\_BIAS requires a minimum load to maintain regulation. MIC\_BIAS maintains regulation within 0.199 and 1.229 mA. Therefore, if you use a microphone with specifications below these limits, the microphone output must be pre-loaded with a large value resistor to ground.

## 2.0 APPLICATIONS

The following sections provide information on designing with the RN52 module, including restoring factory defaults, using the LED interface, minimizing radio interference, solder reflow profile, typical application, etc.

## 2.1 Minimizing Radio Interference

When laying out the host PCB for the RN52 module, the areas under the antenna and shielding connections should not have surface traces, ground planes, or exposed vias (see [Figure 2-1](#)). For optimal radio performance, the RN52 module's antenna end should protrude at least 31 mm beyond any metal enclosure. [Figure 2-2](#) shows examples of good, bad, and acceptable positioning of the RN52 on the host PCB.

**FIGURE 2-1: MINIMIZING RADIO INTERFERENCE**

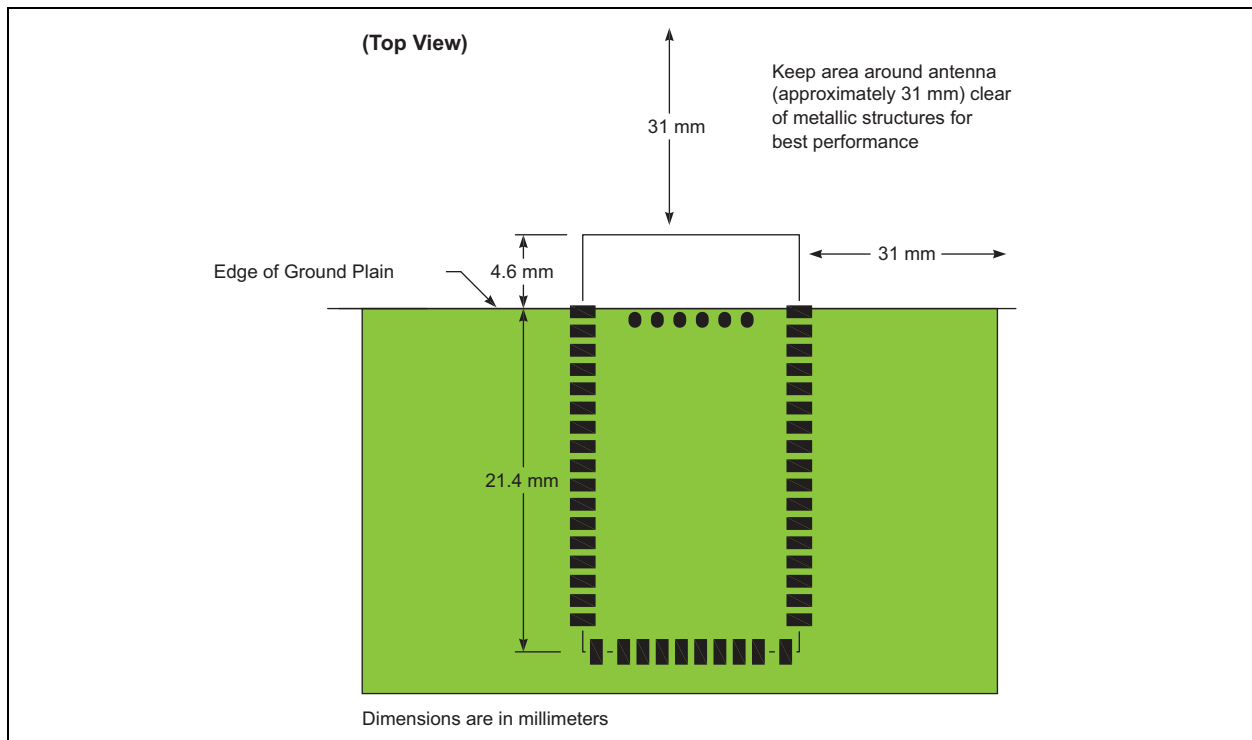

**FIGURE 2-2: PCB EXAMPLE LAYOUT**

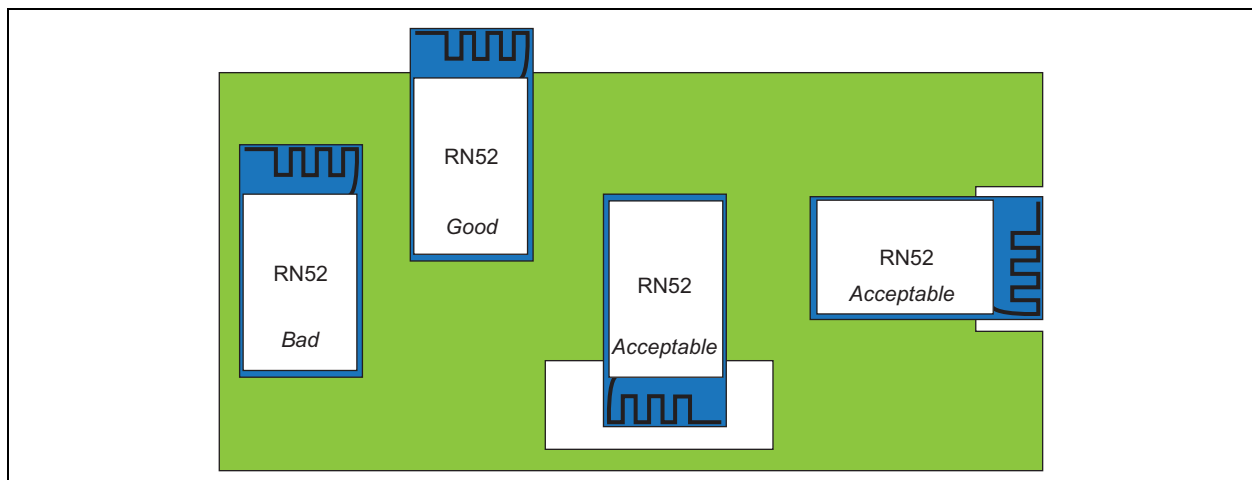

## 2.2 LED Interface

The RN52 includes two pads dedicated to driving the LED indicators. The firmware can control both terminals, and the battery charger can set LED0. The terminals are open-drain outputs; therefore, the LED must be connected from a positive supply rail to the pad in series with a current limiting resistor. You should operate the LED pad (LED0 or LED1 pins) with a pad voltage below 0.5 V. In this case, the pad can be thought of as a resistor,  $R_{ON}$ . The resistance—along with the external series resistor—sets the current,  $I_{LED}$ , in the LED. The current is also dependent on the external voltage,  $V_{DD}$ , as shown in Figure 2-3.

**FIGURE 2-3: LED INTERFACE**

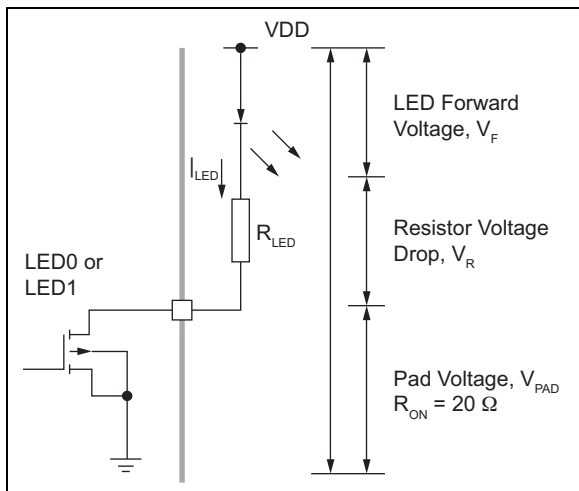

The LEDs can be used to indicate the module's connection status. Table 2-1 describes the LED functions.

**TABLE 2-1: STATUS LED FUNCTIONS**

Blue LED	Red LED	Description
Flashing	Flashing	The RN52 module is discoverable.
Off	Flashing	The module is connected.
Flashing	Off	The module is connectable.

## 2.3 Device Firmware Updates

The module has a device firmware update (DFU) mode in which you use the USB interface to update the firmware. Implementing the DFU feature is recommended highly because firmware updates offer new features and enhance the module's functionality. Follow the reference design shown in Figure 2-7 to support this mode.

**Note:** A 47 K $\Omega$  pull-down resistor (R2 in Figure 2-4) is required on GPIO3 even if you do not use the USB for DFU.

**FIGURE 2-4: USB DFU PORT & GPIO3 SCHEMATIC**

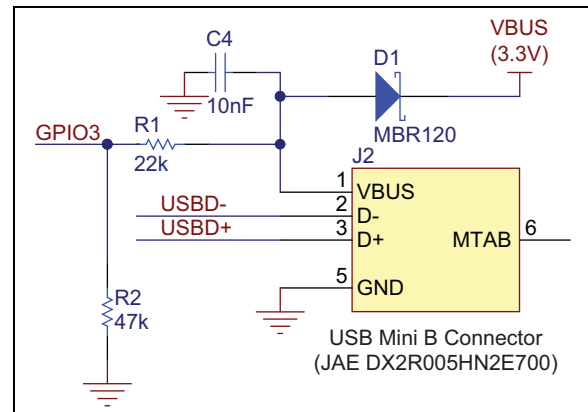

## 2.4 Restore Factory Defaults with GPIO4

You should connect the GPIO4 pin to a switch, jumper, or resistor so it can be accessed. You can use this pin to reset the module to its factory default settings, which is critical in situations where the module has been misconfigured. To reset the module to the factory defaults, GPIO4 should be high on power-up and then toggle low, high, low, high with a 1 second wait between the transitions.

## 2.5 Solder Reflow Profile

The lead-free solder reflow temperature and times are:

- **Temperature**—230° C, 60 seconds maximum, peak 245° C maximum
- **Preheat temperature**—165° ± 15° C, 90 to 120 seconds
- **Time**—Single pass, one time

To reflow solder the module onto a PCB, use an RoHS-compliant solder paste equivalent to NIHON ALMIT paste or OMNIX OM-310 solder paste from Alpha metals. See [Table 2-2](#).

**Note:** Use no-clean flux and DO NOT water wash

**TABLE 2-2: PASTE SOLDER RECOMMENDATIONS**

Manufacturer	Alpha Metals <a href="http://www.alphametals.com">http://www.alphametals.com</a>	NIHON ALMIT Co. LTD <a href="http://almit.co.jp">http://almit.co.jp</a>
Part Number	OMNIX OM-310	LFM-70W INP
Metal Composition	SAC305 (96.5% Sn, 3% Ag, 0.5% Cu)	88% Sn, 3.5% Ag, 0.5% Bi, 8% In
Liquidus Temperature	~220°C	~215°C

Figure 2-5 and Figure 2-6 show the solder reflow temperature profiles.

**FIGURE 2-5: SOLDER REFLOW TEMPERATURE PROFILE**

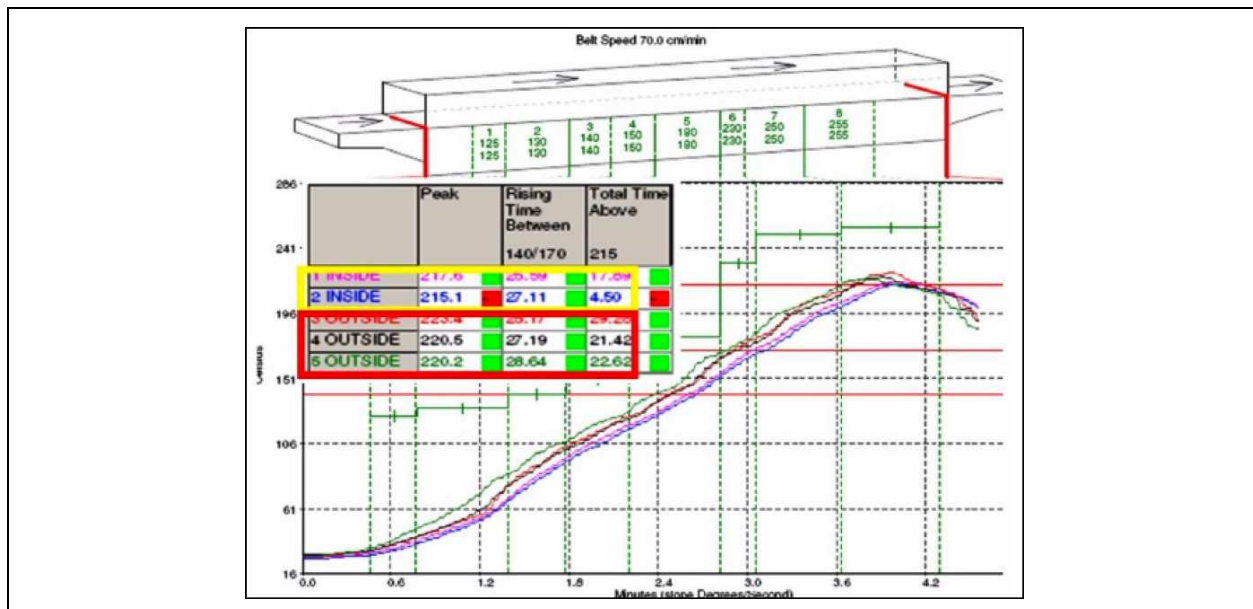
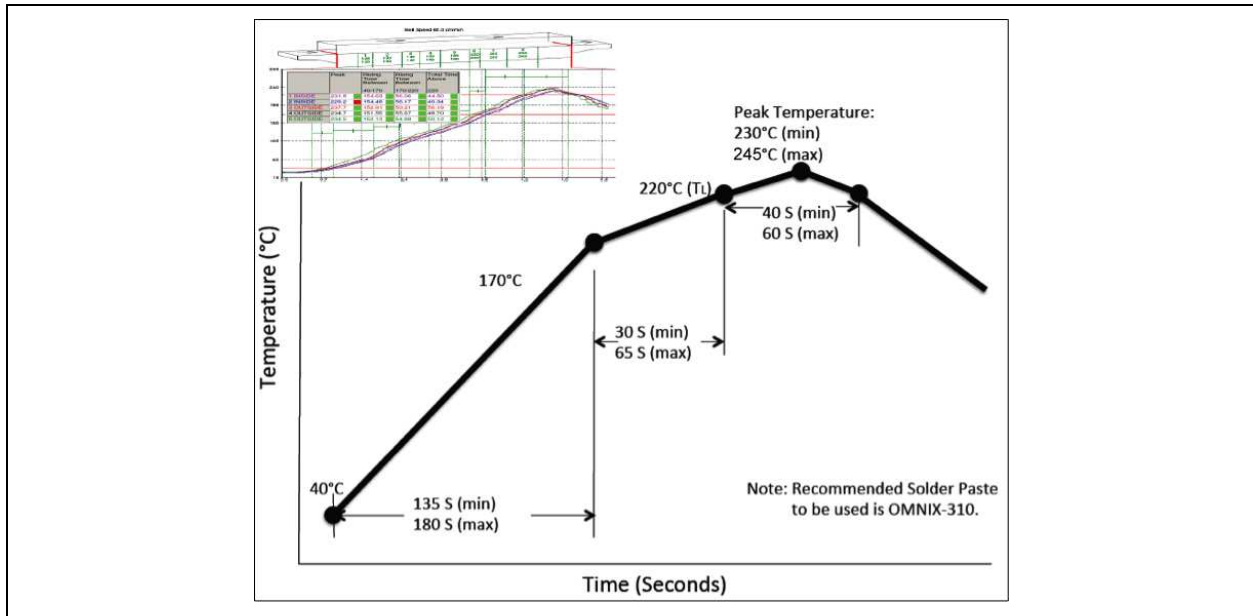

FIGURE 2-6: SOLDER REFLOW CURVE





## 2.6 Typical Application Schematic

Figure 2-7 shows a typical application circuit with LDO, stereo audio/microphone PA, USB/UART, AVRCP switches, and LED0/LED1.

**FIGURE 2-7: TYPICAL APPLICATION CIRCUIT FOR A2DP AUDIO STREAMING & AVRCP REMOTE CONTROL**

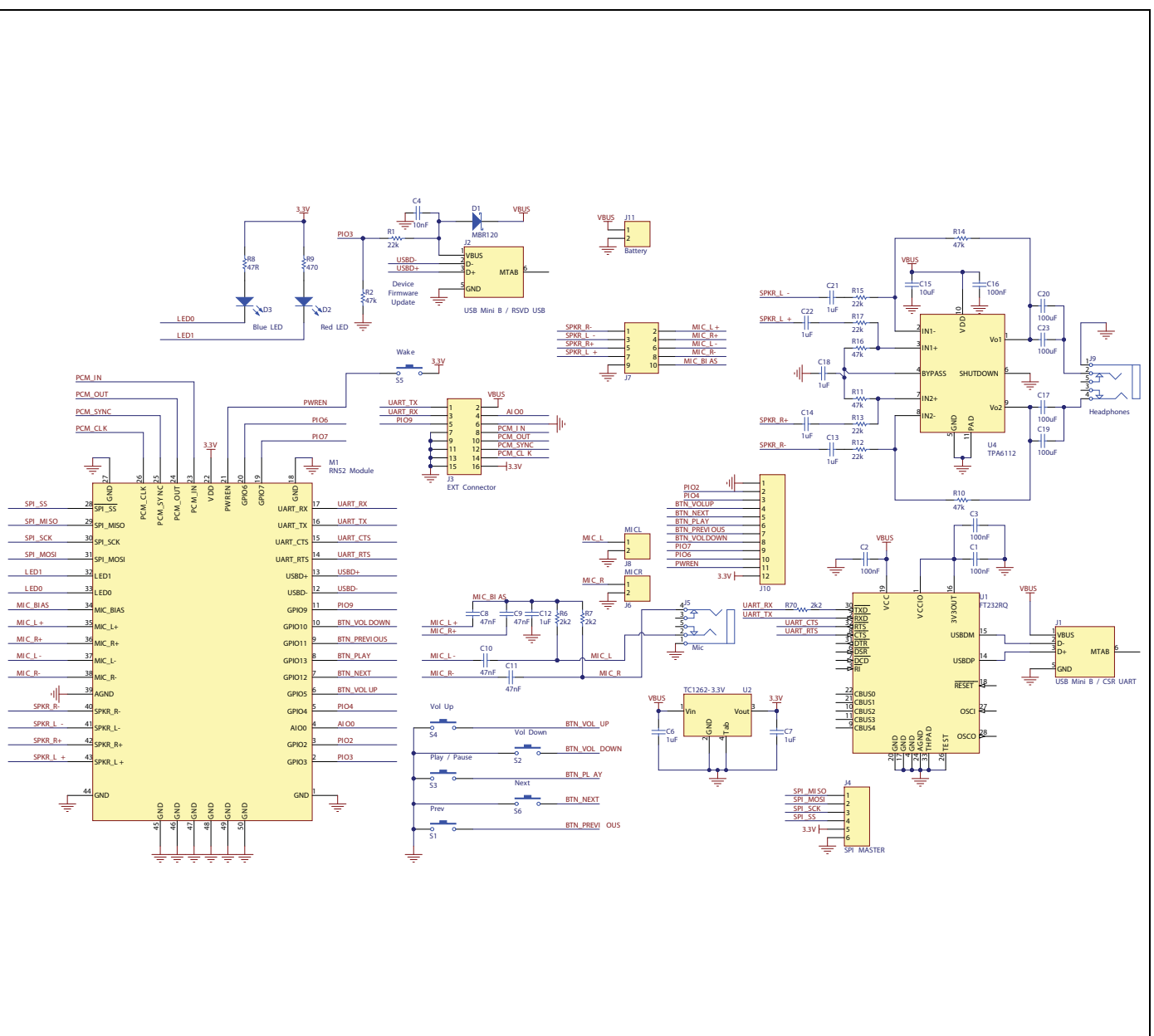

### 3.0 REGULATORY APPROVAL

This section outlines the regulatory information for the RN52 module for the following countries:

- United States
- Canada
- Europe
- Australia
- New Zealand

#### 3.1 United States

The RN52 module has received Federal Communications Commission (FCC) CFR47 Telecommunications, Part 15 Subpart C “Intentional Radiators” modular approval in accordance with Part 15.212 Modular Transmitter approval. Modular approval allows the end user to integrate the RN52 module into a finished product without obtaining subsequent and separate FCC approvals for intentional radiation, provided no changes or modifications are made to the module circuitry. Changes or modifications could void the user’s authority to operate the equipment. The end user must comply with all of the instructions provided by the Grantee, which indicate installation and/or operating conditions necessary for compliance.

The finished product is required to comply with all applicable FCC equipment authorizations regulations, requirements and equipment functions not associated with the transmitter module portion. For example, compliance must be demonstrated to regulations for other transmitter components within the host product; to requirements for unintentional radiators (Part 15 Subpart B “Unintentional Radiators”), such as digital devices, computer peripherals, radio receivers, etc.; and to additional authorization requirements for the non-transmitter functions on the transmitter module (i.e., Verification, or Declaration of Conformity) (e.g., transmitter modules may also contain digital logic functions) as appropriate.

##### 3.1.1 LABELING AND USER INFORMATION REQUIREMENTS

The RN52 module has been labeled with its own FCC ID number, and if the FCC ID is not visible when the module is installed inside another device, then the outside of the finished product into which the module is

installed must also display a label referring to the enclosed module. This exterior label can use wording as follows:

Contains Transmitter Module FCC ID: T9J-RN52

or

Contains FCC ID: T9J-RN52

This device complies with Part 15 of the FCC Rules. Operation is subject to the following two conditions: (1) this device may not cause harmful interference, and (2) this device must accept any interference received, including interference that may cause undesired operation

A user’s manual for the product should include the following statement:

This equipment has been tested and found to comply with the limits for a Class B digital device, pursuant to part 15 of the FCC Rules. These limits are designed to provide reasonable protection against harmful interference in a residential installation. This equipment generates, uses and can radiate radio frequency energy, and if not installed and used in accordance with the instructions, may cause harmful interference to radio communications. However, there is no guarantee that interference will not occur in a particular installation. If this equipment does cause harmful interference to radio or television reception, which can be determined by turning the equipment off and on, the user is encouraged to try to correct the interference by one or more of the following measures:

- Reorient or relocate the receiving antenna.
- Increase the separation between the equipment and receiver.
- Connect the equipment into an outlet on a circuit different from that to which the receiver is connected.
- Consult the dealer or an experienced radio/TV technician for help.

Additional information on labeling and user information requirements for Part 15 devices can be found in KDB Publication 784748 available at the FCC Office of Engineering and Technology (OET) Laboratory Division Knowledge Database (KDB) <http://apps.fcc.gov/oetcf/kdb/index.cfm>.

##### 3.1.2 RF EXPOSURE

All transmitters regulated by FCC must comply with RF exposure requirements. OET Bulletin 65, Evaluating Compliance with FCC Guidelines for Human Exposure

to Radio Frequency Electromagnetic Fields, provides assistance in determining whether proposed or existing transmitting facilities, operations or devices comply with limits for human exposure to Radio Frequency (RF) fields adopted by the Federal Communications Commission (FCC). The bulletin offers guidelines and suggestions for evaluating compliance.

If appropriate, compliance with exposure guidelines for mobile and unlicensed devices can be accomplished by the use of warning labels and by providing users with information concerning minimum separation distances from transmitting structures and proper installation of antennas.

The following statement must be included as a CAUTION statement in manuals and OEM products to alert users of FCC RF exposure compliance:

To satisfy FCC RF Exposure requirements for mobile and base station transmission devices, a separation distance of 20 cm or more should be maintained between the antenna of this device and persons during operation. To ensure compliance, operation at closer than this distance is not recommended.

The antenna(s) used for this transmitter must not be co-located or operating in conjunction with any other antenna or transmitter.

If the RN52 module is used in a portable application (i.e., the antenna is less than 20 cm from persons during operation), the integrator is responsible for performing Specific Absorption Rate (SAR) testing in accordance with FCC rules 2.1091.

### 3.1.3 HELPFUL WEB SITES

Federal Communications Commission (FCC): <http://www.fcc.gov>

FCC Office of Engineering and Technology (OET) Laboratory Division Knowledge Database (KDB): <http://apps.fcc.gov/oetcf/kdb/index.cfm>

## 3.2 Canada

The RN52 module has been certified for use in Canada under Industry Canada (IC) Radio Standards Specification (RSS) RSS-210 and RSSGen. Modular approval permits the installation of a module in a host device without the need to recertify the device.

### 3.2.1 LABELING AND USER INFORMATION REQUIREMENTS

Labeling Requirements for the Host Device (from Section 3.2.1, RSS-Gen, Issue 3, December 2010): The host device shall be properly labeled to identify the module within the host device.

The Industry Canada certification label of a module shall be clearly visible at all times when installed in the host device, otherwise the host device must be labeled to display the Industry Canada certification number of the module, preceded by the words “Contains transmitter module”, or the word “Contains”, or similar wording expressing the same meaning, as follows:

Contains transmitter module IC: 6514A-RN52

User Manual Notice for License-Exempt Radio Apparatus (from Section 7.1.3 RSS-Gen, Issue 3, December 2010): User manuals for license-exempt radio apparatus shall contain the following or equivalent notice in a conspicuous location in the user manual or alternatively on the device or both:

This device complies with Industry Canada license-exempt RSS standard(s). Operation is subject to the following two conditions: (1) this device may not cause interference, and (2) this device must accept any interference, including interference that may cause undesired operation of the device.

Le présent appareil est conforme aux CNR d'Industrie Canada applicables aux appareils radio exempts de licence. L'exploitation est autorisée aux deux conditions suivantes: (1) l'appareil ne doit pas produire de brouillage, et (2) l'utilisateur de l'appareil doit accepter tout brouillage radioélectrique subi, même si le brouillage est susceptible d'en compromettre le fonctionnement.

Transmitter Antenna (from Section 7.1.2 RSS-Gen, Issue 3, December 2010): User manuals for transmitters shall display the following notice in a conspicuous location:

Under Industry Canada regulations, this radio transmitter may only operate using an antenna of a type and maximum (or lesser) gain approved for the transmitter by Industry Canada. To reduce potential radio interference to other users, the antenna type and its gain should be so chosen that the equivalent isotropically radiated power (e.i.r.p.) is not more than that necessary for successful communication.

Conformément à la réglementation d'Industrie Canada, le présent émetteur radio peut fonctionner avec une antenne d'un type et d'un gain maximal (ou inférieur) approuvé pour l'émetteur par Industrie Canada. Dans le but de réduire les risques de brouillage radioélectrique à l'intention des autres utilisateurs, il faut choisir le type d'antenne et son gain de sorte que la puissance isotrope rayonnée équivalente (p.i.r.e.) ne dépasse pas l'intensité nécessaire à l'établissement d'une communication satisfaisante.

The above notice may be affixed to the device instead of displayed in the user manual.

### 3.2.2 HELPFUL WEB SITES

Industry Canada: <http://www.ic.gc.ca/>

## 3.3 Europe

The RN52 module is an R&TTE Directive assessed radio module that is CE marked and has been manufactured and tested with the intention of being integrated into a final product.

The RN52 module has been tested to R&TTE Directive 1999/5/EC Essential Requirements for Health and Safety (Article (3.1(a)), Electromagnetic Compatibility (EMC) (Article 3.1(b)), and Radio (Article 3.2) and are summarized in Table 3-1: European Compliance Testing. A Notified Body Opinion has also been issued. All test reports are available on the RN52 product web page at <http://www.microchip.com>.

The R&TTE Compliance Association provides guidance on modular devices in document Technical Guidance Note 01 available at [http://www.rtteca.com/html/download\\_area.htm](http://www.rtteca.com/html/download_area.htm).

**Note:** To maintain conformance to the testing listed in [Table 3-1](#), the module shall be installed in accordance with the installation instructions in this data sheet and shall not be modified.

When integrating a radio module into a completed product the integrator becomes the manufacturer of the final product and is therefore responsible for demonstrating compliance of the final product with the essential requirements of the R&TTE Directive.

### 3.3.1 LABELING AND USER INFORMATION REQUIREMENTS

The label on the final product which contains the RN52 module must follow CE marking requirements. The R&TTE Compliance Association Technical Guidance Note 01 provides guidance on final product CE marking.

### 3.3.2 ANTENNA REQUIREMENTS

From R&TTE Compliance Association document Technical Guidance Note 01:

Provided the integrator installing an assessed radio module with an integral or specific antenna and installed in conformance with the radio module manufacturer's installation instructions requires no further evaluation under Article 3.2 of the R&TTE Directive and does not require further involvement of an R&TTE Directive Notified Body for the final product. [Section 2.2.4]

### 3.3.3 HELPFUL WEB SITES

A document that can be used as a starting point in understanding the use of Short Range Devices (SRD) in Europe is the European Radio Communications Committee (ERC) Recommendation 70-03 E, which can be downloaded from the European Radio Communications Office (ERO) at: <http://www.ero.dk/>.

Additional helpful web sites are:

- Radio and Telecommunications Terminal Equipment (R&TTE):  
[http://ec.europa.eu/enterprise/rtte/index\\_en.htm](http://ec.europa.eu/enterprise/rtte/index_en.htm)
- European Conference of Postal and Telecommunications Administrations (CEPT):  
<http://www.cept.org>
- European Telecommunications Standards Institute (ETSI):  
<http://www.etsi.org>
- European Radio Communications Office (ERO):  
<http://www.ero.dk>
- The Radio and Telecommunications Terminal Equipment Compliance Association (R&TTE CA):  
<http://www.rtteca.com/>

**TABLE 3-1: EUROPEAN COMPLIANCE TESTING**

Certification	Standards	Article	Laboratory	Report Number	Date
Safety	EN 60950-1:2006+A11:2009+A1:2010	(3.1(a))			
Health	EN 50371:2002-03				
EMC	EN 301 489-1 V1.8.1 (2008-04)	(3.1(b))			
	EN 301 489-17 V2.1.1 (2009-05)				
Radio	EN 300 328 V1.7.1 (2006-10)	(3.2)			
Notified Body Opinion					
DoC					

### 3.4 Australia

The Australia radio regulations do not provide a modular approval policy similar to the United States (FCC) and Canada (IC). However, RN52 module RF transmitter test reports can be used in part to demonstrate compliance in accordance with ACMA Radio communications “Short Range Devices” Standard 2004 (The Short Range Devices standard calls up the AS/NZS 4268:2008 industry standard). The RN52 module test reports can be used as part of the product certification and compliance folder. For more information on the RF transmitter test reports, contact Microchip Technology Australia sales office.

To meet overall Australian final product compliance, the developer must construct a compliance folder containing all relevant compliance test reports e.g. RF, EMC, electrical safety and DoC (Declaration of Conformity) etc. It is the responsibility of the integrator to know what is required in the compliance folder for ACMA compliance. All test reports are available on the RN52 product web page at <http://www.microchip.com>. For more information on Australia compliance, refer to the Australian Communications and Media Authority web site <http://www.acma.gov.au/>.

#### 3.4.1 HELPFUL WEB SITES

The Australian Communications and Media Authority: [www.acma.gov.au/](http://www.acma.gov.au/).

### 3.5 New Zealand

The New Zealand radio regulations do not provide a modular approval policy similar to the United States (FCC) and Canada (IC). However, RN52 module RF transmitter test reports can be used in part to demonstrate compliance against the New Zealand “General User Radio License for Short Range Devices”. New Zealand Radio communications (Radio Standards) Notice 2010 calls up the AS / NZS 4268:2008 industry standard. The RN52 module test reports can be used

as part of the product certification and compliance folder. All test reports are available on the RN52 product web page at <http://www.microchip.com>. For more information on the RF transmitter test reports, contact Microchip Technology sales office.

Information on the New Zealand short range devices license can be found in the following web links:

<http://www.rsm.govt.nz/cms/licensees/types-of-licence/general-user-licences/short-range-devices>

and

<http://www.rsm.govt.nz/cms/policy-and-planning/spectrum-policy-overview/legislation/gazette-notices/product-compliance/radiocommunications-radiostandards-notice-2010>.

To meet overall New Zealand final product compliance, the developer must construct a compliance folder containing all relevant compliance test reports e.g. RF, EMC, electrical safety and DoC (Declaration of Conformity) etc. It is the responsibility of the developer to know what is required in the compliance folder for New Zealand Radio communications. For more information on New Zealand compliance, refer to the web site <http://www.rsm.govt.nz/>.

#### 3.5.1 HELPFUL WEB SITES

Radio Spectrum Ministry of Economic Development: <http://www.rsm.govt.nz/>.



## 4.0 ORDERING INFORMATION

Table 4-1 provides ordering information for the RN52 module.

**TABLE 4-1: ORDERING INFORMATION**

Part Number	Description
RN52-I/RM	Standard application firmware (A2DP/AVRCP/SPP) master and slave).
For other configurations, contact Roving Networks directly.	

Go to <http://www.rovingnetworks.com> for current pricing and a list of distributors carrying Roving Networks products.

## 5.0 DOCUMENT REVISION HISTORY

### 5.1 Version 1.1

- Updated pin information.
- Added more details on RN52 layout o host PCB.

### 5.2 Version 1.0

Initial release.

*This device has not been authorized as required by the rules of the Federal Communications Commission. This device is not, and may not be, offered for sale or lease, or sold or leased, until authorization is obtained.*

Copyright © 2013 Roving Networks. All rights reserved. Roving Networks is a registered trademark of Roving Networks. Apple Inc., iPhone, iPad, iTunes, Made for iPhone are registered trademarks of Apple Computer.

Roving Networks reserves the right to make corrections, modifications, and other changes to its products, documentation and services at any time. Customers should obtain the latest relevant information before placing orders and should verify that such information is current and complete.

Roving Networks assumes no liability for applications assistance or customer's product design. Customers are responsible for their products and applications that use Roving Networks components. To minimize customer product risks, customers should provide adequate design and operating safeguards.

Roving Networks products are not authorized for use in safety-critical applications (such as life support) where a failure of the Roving Networks product would reasonably be expected to cause severe personal injury or death, unless officers of the parties have executed an agreement specifically governing such use.

Roving Networks, Inc.  
 102 Cooper Court  
 Los Gatos, CA 95032  
 +1 (408) 395-5300  
[www.rovingnetworks.com](http://www.rovingnetworks.com)