



Chipsmall Limited consists of a professional team with an average of over 10 year of expertise in the distribution of electronic components. Based in Hongkong, we have already established firm and mutual-benefit business relationships with customers from,Europe,America and south Asia,supplying obsolete and hard-to-find components to meet their specific needs.

With the principle of “Quality Parts,Customers Priority,Honest Operation,and Considerate Service”,our business mainly focus on the distribution of electronic components. Line cards we deal with include Microchip,ALPS,ROHM,Xilinx,Pulse,ON,Everlight and Freescale. Main products comprise IC,Modules,Potentiometer,IC Socket,Relay,Connector.Our parts cover such applications as commercial,industrial, and automotives areas.

We are looking forward to setting up business relationship with you and hope to provide you with the best service and solution. Let us make a better world for our industry!



## Contact us

Tel: +86-755-8981 8866 Fax: +86-755-8427 6832

Email & Skype: info@chipsmall.com Web: www.chipsmall.com

Address: A1208, Overseas Decoration Building, #122 Zhenhua RD., Futian, Shenzhen, China





**MODEL:** WST-1310S-3  
**PRODUCT:** Electromagnetic Buzzer  
**EDITION:** A/2016

**THIS SPECIFICATION APPLIES TO THE ELECTROMAGNETIC BUZZER**

**SPECIFICATION**

Test condition: TEMP=+25±2 °C Related humidity=65±5% Air pressure: 860 ~ 1060mbar

item	unit	specification	condition
rated voltage	Vo-p	12.0	
operating volt	Vo-p	8.0 ~ 16.0	
mean current	mA	Max.30	At rated voltage direct current
sound output	dba	85	At 10cm(A-weight free air), at rated voltage direct current
rated frequency	Hz	2300 ± 300	
operating temp	°C	-20 ~ +70	
storage temp	°C	-30 ~ +80	
dimension	mm	L12.8 x W12.8 x H10.0	See attached drawing
weight	gram	2.8	
material		PPS (Gray)	
terminal		SMD type (Plating Sn)	See attached drawing
environmental protection regulation		RoHS	

**ENVIRONMENT TEST**

item	test condition	evaluation standard
high temp. test	After being placed in a chamber at +80°C for 96 hours.	After the test the part will meet specifications without any degradation in appearance and performance except SPL, after 4 hours at +25°C. The SPL will be in ±10dba compared with initial one.
low temp. test	After being placed in a chamber at -30°C for 96 hours.	
thermal shock	The part will be subjected to 10 cycles. One cycle shall consist of:	

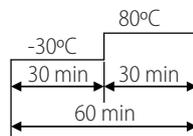

temp./humidity cycle The part will be subjected to 10 cycles.  
One cycle shall be 24 hours and consist of:

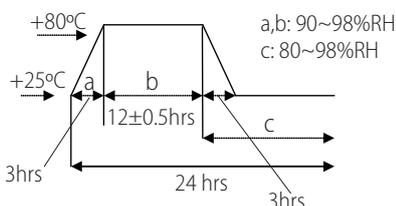



**MODEL:** WST-1310S-3  
**PRODUCT:** Electromagnetic Buzzer  
**EDITION:** A/2016

**RELIABILITY TEST**

item	test conditions	evaluation standard
operating life test	ORDINARY TEMPERATURE The part shall be subjected to 96 hours of continuous operation at room temperature.	After the test the part will meet specifications without any degradation in appearance and performance except SPL, after 4 hours at +25°C. The SPL would be in ±10dBA compared with initial one.
	HIGH TEMPERATURE The part shall be subjected to 72 hours of continuous operation at +60°C with 12.0V applied.	
	LOW TEMPERATURE The part shall be subjected to 72 hours of continuous operation at -20°C with 12.0V applied.	
	HIGH AND LOW VOLTAGE Applying 8.0 voltage and 16.0 voltage, available time 24 hours each.	

**TEST CONDITION**

Standard Test Condition: a)Temperature: +5~+35°C b)Humidity:45~85% c)Pressure: 860~1060mbar

**MECHANICAL CHARACTERISTICS**

item	test conditions	evaluation standard
solderability	Lead terminal are immersed in rosin for 5 seconds and then immersed in solder bath of +250±5°C for 3±0.5 seconds.	90% min. lead terminals will be wet with solder No interference in operation.
soldering heat resistance	Lead terminal are immersed in soldering bath of +250±5°C for 2±0.5 seconds.	
terminal mechanical strength	Apply the terminal with 1KG tension for 1 minute.	No damage and cutting off.
vibration	The part will be subjected to a vibration cycle of 10Hz to 55Hz to 10Hz in a period of 1 minute. Total peak amplitude will be 1.52mm(9.3G). The vibration test will consist of 2 hours per axis in each three axes(X,Y,Z). Total 6 hours.	After the test the part will meet specifications without any damage in appearance and performance except SPL. The SPL would be in ±80dBA compared with initial one.
drop test	The part only will be dropped from a height of 75cm onto a 40mm thick wooden board 3 times in 3 axes(X,Y,Z). Total of 9 times.	

**RECOMMENDED TEMPERATURE PROFILE FOR REFLOW OVEN**

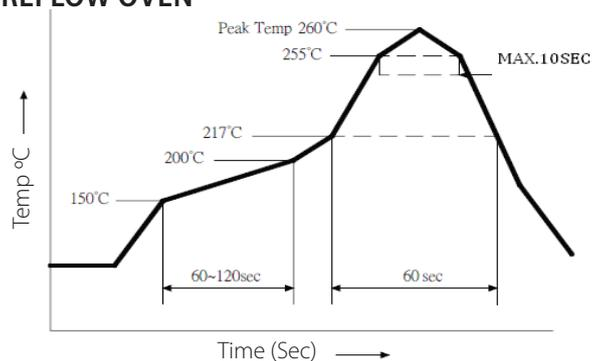



**MODEL:** WST-1310S-3  
**PRODUCT:** Electromagnetic Buzzer  
**EDITION:** A/2016

**MEASUREMENT TEST CIRCUIT**

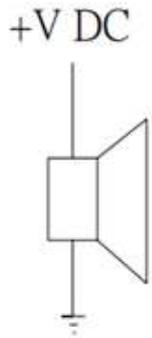

**INSPECTION FIXTURE**

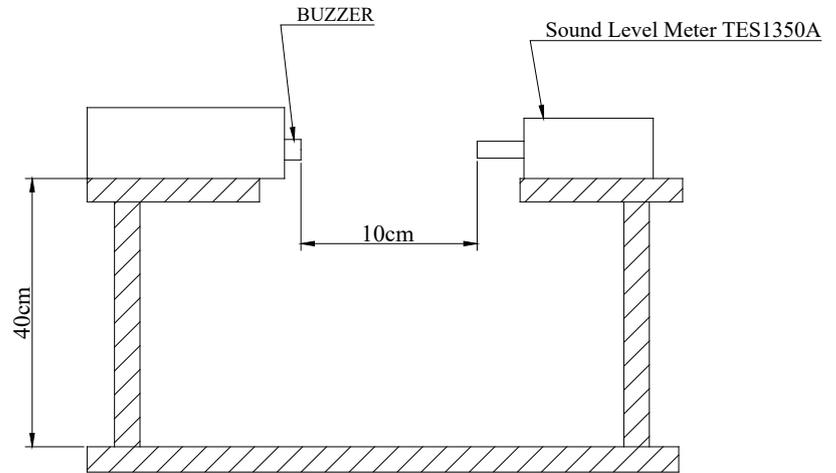

**FREQUENCY RESPONSE**

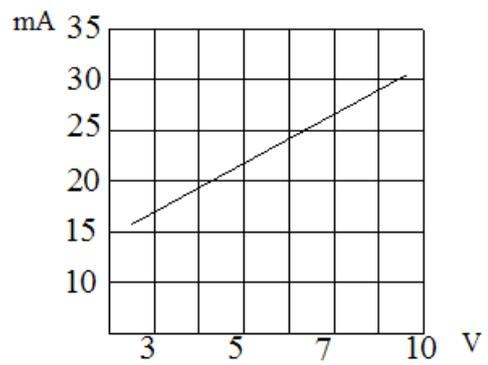
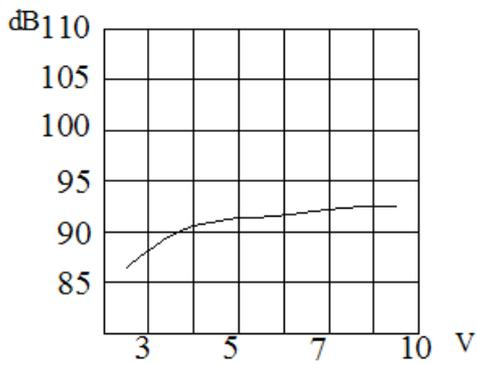

**RECOMMENDED LAND PATTERN**

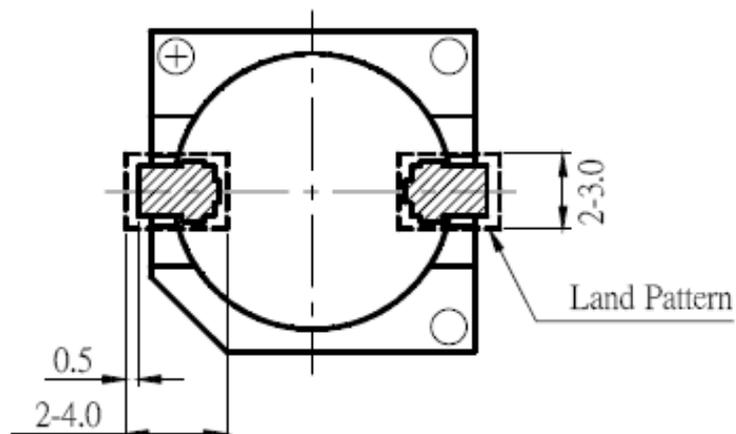



**MODEL:** WST-1310S-3  
**PRODUCT:** Electromagnetic Buzzer  
**EDITION:** A/2016

**DIMENSIONS**

Tolerance: ±0.5 (unit: mm)

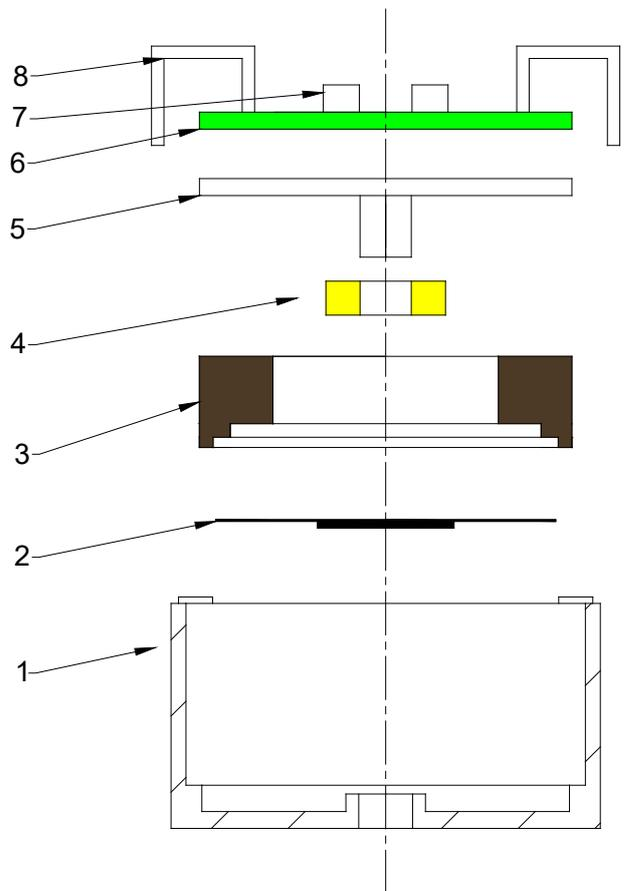
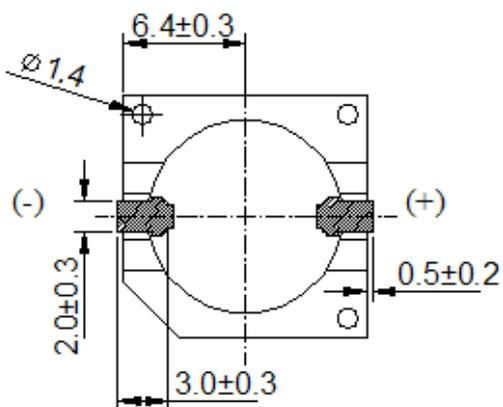
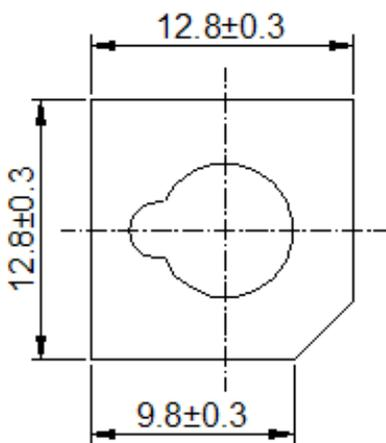
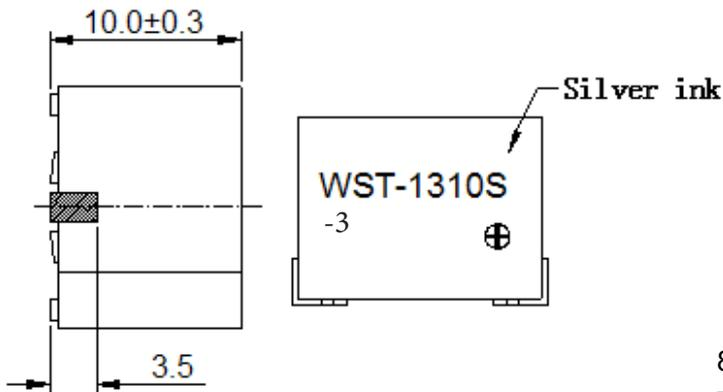

no	item	material	quantity
1	CASE	PPS	1
2	Diaphragm	Ferrum	1
3	Magnet ring	Poly+ferrite	1
4	Coil	Copper	1
5	Core	Ferrum	1
6	PCB	Epoxy glass fiber cloth + copper	1
7	Transistor	Epoxy + copper	2
8	PIN	Copper	2



**MODEL:** WST-1310S-3  
**PRODUCT:** Electromagnetic Buzzer  
**EDITION:** A/2016

**PACKING**

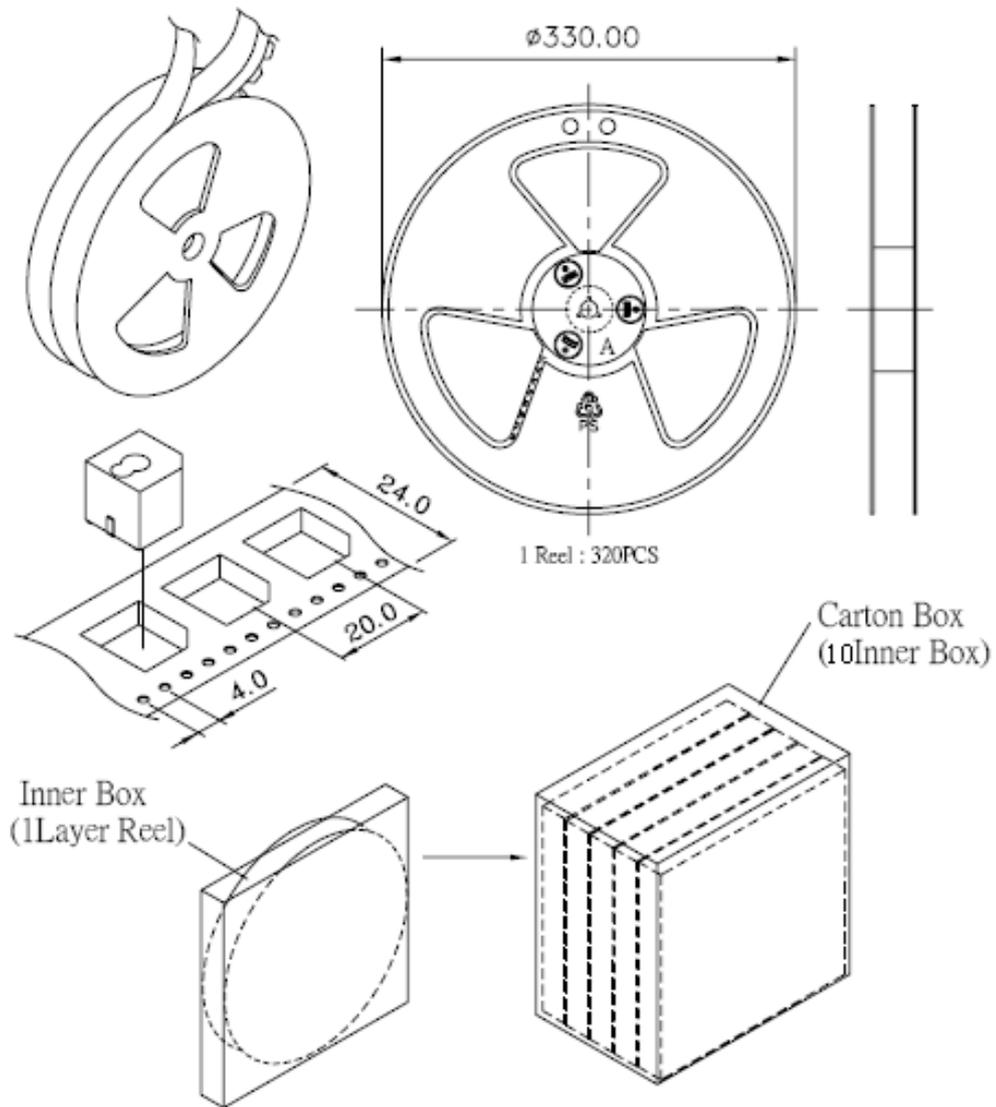

packing box	LxWxH (mm)	pieces
Inner box	340 x 340 x 40	1 x 320 = 320
Carton box	360 x 360 x 420	10 x 320 = 3,200