



Chipsmall Limited consists of a professional team with an average of over 10 year of expertise in the distribution of electronic components. Based in Hongkong, we have already established firm and mutual-benefit business relationships with customers from,Europe,America and south Asia,supplying obsolete and hard-to-find components to meet their specific needs.

With the principle of "Quality Parts,Customers Priority,Honest Operation,and Considerate Service",our business mainly focus on the distribution of electronic components. Line cards we deal with include Microchip,ALPS,ROHM,Xilinx,Pulse,ON,Everlight and Freescale. Main products comprise IC,Modules,Potentiometer,IC Socket,Relay,Connector.Our parts cover such applications as commercial,industrial, and automotives areas.

We are looking forward to setting up business relationship with you and hope to provide you with the best service and solution. Let us make a better world for our industry!



Contact us

Tel: +86-755-8981 8866 Fax: +86-755-8427 6832

Email & Skype: info@chipsmall.com Web: www.chipsmall.com

Address: A1208, Overseas Decoration Building, #122 Zhenhua RD., Futian, Shenzhen, China





WT12

Data Sheet

Version 2.8

Friday, May 22, 2009

Copyright © 2000-2009 Bluegiga Technologies

All rights reserved.

Bluegiga Technologies assumes no responsibility for any errors, which may appear in this manual. Furthermore, Bluegiga Technologies reserves the right to alter the hardware, software, and/or specifications detailed herein at any time without notice, and does not make any commitment to update the information contained herein. Bluegiga Technologies' products are not authorized for use as critical components in life support devices or systems.

The WRAP is a registered trademark of Bluegiga Technologies

The *Bluetooth* trademark is owned by the *Bluetooth* SIG Inc., USA, and is licensed to Bluegiga Technologies.

All other trademarks listed herein are owned by their respective owners.

Contents:

1.	Block Diagram and Descriptions	6
2.	Electrical Characteristics	8
2.1	Radio Characteristics – Basic Data Rate	11
2.2	Radio Characteristics – Enhanced Data Rate	14
3.	WT12 Pin Description	16
4.	Physical Interfaces	19
4.1	UART Interface	19
4.1.1	UART Configuration While RESET is Active	20
4.1.2	UART Bypass Mode	20
4.2	USB Interface	22
4.2.1	USB Pull-Up Resistor	22
4.2.2	Self Powered Mode	22
4.2.3	Bus Powered Mode	23
4.2.4	Suspend Current	24
4.2.5	Detach and Wake-Up Signaling	24
4.2.6	USB Driver	25
4.2.7	USB 1.1 Compliance	25
4.2.8	USB 2.0 Compatibility	25
4.3	SPI Interface	26
4.4	PCM Interface	27
4.4.1	PCM Interface Master/Slave	27
4.4.2	Long Frame Sync	28
4.4.3	Short Frame Sync	28
4.4.4	Multi Slot Operation	29
4.4.5	GCI Interface	29
4.4.6	Slots and Sample Formats	30
4.4.7	Additional Features	31
4.4.8	PCM Configuration	31

5. I / O Parallel Ports	33
6. Software Stacks	34
6.1 iWRAP Stack.....	34
6.2 HCI Stack.....	35
6.3 RFCOMM Stack.....	38
6.4 VM Stack.....	39
6.5 HID Stack	40
7. Enhanced Data Rate	42
7.1 Enhanced Data Rate Baseband	42
7.2 Enhanced Data Rate $\Pi/4$ DQPSK.....	42
7.3 8DQPSK.....	42
8. Layout and Soldering Considerations	44
8.1 Soldering recommendations.....	44
8.2 Layout guidelines	44
9. WT12 physical dimensions	47
10. Package	49
11. Certifications	51
11.1 Bluetooth.....	51
11.2 FCC.....	52
11.3 CE	52
11.4 Industry Canada (IC).....	53
12. RoHS Statement with a List of Banned Materials	54
13. Contact Information	55

TERMS & ABBREVIATIONS

Term or Abbreviation:	Explanation:
<i>Bluetooth</i>	Set of technologies providing audio and data transfer over short-range radio connections
<i>CE</i>	Conformité Européene
<i>DFU</i>	Device Firmware Upgrade
<i>EDR</i>	Enhanced Data Rate
<i>FCC</i>	Federal Communications Commission
<i>HCI</i>	Host Controller Interface
<i>HID</i>	Human Interface Device
<i>iWRAP</i>	Interface for WRAP
<i>PCB</i>	Printed Circuit Board
<i>PCM</i>	Pulse Code Modulation
<i>RoHS</i>	The Restriction of Hazardous Substances in Electrical and Electronic Equipment Directive (2002/95/EC)
<i>SPI</i>	Serial Peripheral Interface
<i>UART</i>	Universal Asynchronous Transmitter Receiver
<i>USB</i>	Universal Serial Bus
<i>VM</i>	Virtual Machine
<i>WRAP</i>	Wireless Remote Access Platform

DESCRIPTION

WT12 is a next-generation, class 2, Bluetooth® 2.0+EDR (Enhanced Data Rates) module. It introduces three times faster data rates compared to existing Bluetooth® 1.2 modules even with lower power consumption! WT12 is a highly integrated and sophisticated Bluetooth® module, containing all the necessary elements from Bluetooth® radio to antenna and a fully implemented protocol stack. Therefore WT12 provides an ideal solution for developers who want to integrate Bluetooth® wireless technology into their design with limited knowledge of Bluetooth® and RF technologies.

By default WT12 module is equipped with powerful and easy-to-use iWRAP firmware. iWRAP enables users to access Bluetooth® functionality with simple ASCII commands delivered to the module over serial interface - it's just like a Bluetooth® modem.

APPLICATIONS:

- Hand held terminals
- Industrial devices
- Point-of-Sale systems
- PCs
- Personal Digital Assistants (PDAs)
- Computer Accessories
- Access Points
- Automotive Diagnostics Units

FEATURES:

- Fully Qualified Bluetooth system v2.0 + EDR, CE and FCC
- Integrated chip antenna
- Industrial temperature range from -40°C to +85°C
- Enhanced Data Rate (EDR) compliant with v2.0.E.2 of specification for both 2Mbps and 3Mbps modulation modes
- RoHS Compliant
- Full Speed Bluetooth Operation with Full Piconet
- Scatternet Support
- USB version 2.0 compatible
- UART with bypass mode
- Support for 802.11 Coexistence
- 8Mbits of Flash Memory



Figure 1: Physical outlook of WT12

ORDERING INFORMATION:

	Internal chip antenna
iWRAP 3.0 firmware	WT12-A-AI3
iWRAP 2.2.0 firmware	WT12-A-AI
HCI firmware, BT2.1 + EDR	WT12-A-HCI21
HCI firmware, BT2.0 + EDR	WT12-A-HCI
Custom firmware	WT12-A-C (*)

Table 1: Ordering information

**) Custom firmware means any standard firmware with custom parameters (like UART baud rate), custom firmware developer by customer or custom firmware developed by Bluegiga for the customer.*

To order custom firmware you must have a properly filled Custom Firmware Order Form and unique ordering code issued by Bluegiga.

Contact support@bluegiga.com for more information.

1. BLOCK DIAGRAM AND DESCRIPTIONS

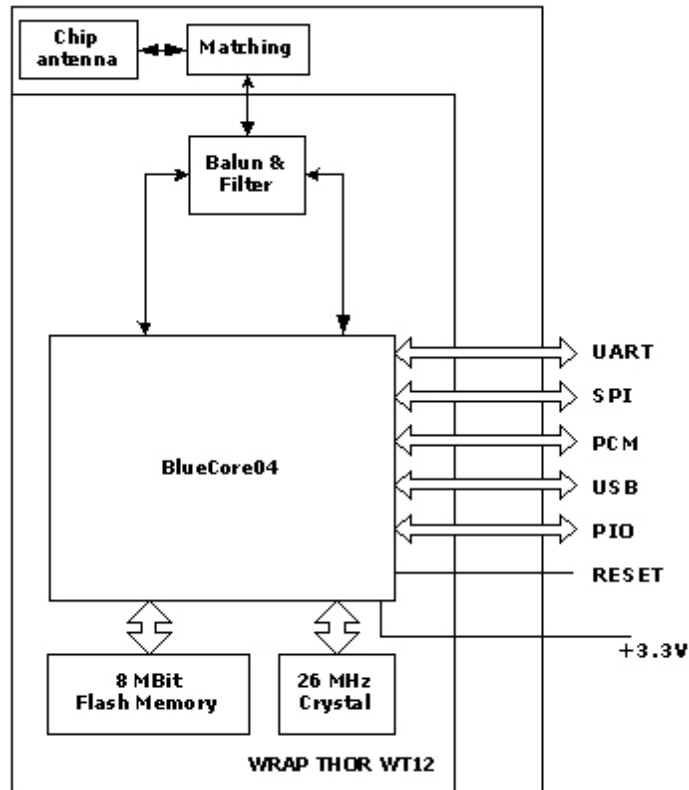

Figure 2: Block Diagram of WT12

BlueCore04

BlueCore04 is a single chip Bluetooth solution which implements the Bluetooth radio transceiver and also an on chip microcontroller. BlueCore04 implements Bluetooth® 2.0+ EDR (Enhanced Data Rate) and it can deliver data rates up to 3 Mbps.

The microcontroller (MCU) on BlueCore04 acts as interrupt controller and event timer run the Bluetooth software stack and control the radio and host interfaces. A 16-bit reduced instruction set computer (RISC) microcontroller is used for low power consumption and efficient use of memory.

BlueCore04 has 48Kbytes of on-chip RAM is provided to support the RISC MCU and is shared between the ring buffers used to hold voice/data for each active connection and the general purpose memory required by the Bluetooth stack.

Crystal

The crystal oscillates at 26MHz.

Flash

Flash memory is used for storing the Bluetooth protocol stack and Virtual Machine applications. It can also be used as an optional external RAM for memory intensive applications.

Balun / filter

Combined balun and filter changes the balanced input/output signal of the module to unbalanced signal of the monopole antenna. The filter is a band pass filter (ISM band).

Matching

Antenna matching components match the antenna to 50 Ohms.

Antenna

The antenna is ACX AT3216 chip antenna.

USB

This is a full speed Universal Serial Bus (USB) interface for communicating with other compatible digital devices. WT12 acts as a USB peripheral, responding to requests from a Master host controller such as a PC.

Synchronous Serial Interface

This is a synchronous serial port interface (SPI) for interfacing with other digital devices. The SPI port can be used for system debugging. It can also be used for programming the Flash memory.

UART

This is a standard Universal Asynchronous Receiver Transmitter (UART) interface for communicating with other serial devices.

Audio PCM Interface

The audio pulse code modulation (PCM) Interface supports continuous transmission and reception of PCM encoded audio data over Bluetooth.

Programmable I / O

WT12 has a total of 6 digital programmable I/O terminals. These are controlled by firmware running on the device.

Reset

This can be used to reset WT12.

802.11 Coexistence Interface

Dedicated hardware is provided to implement a variety of coexistence schemes. Channel skipping AFH (Adaptive Frequency Hopping), priority signaling, channel signaling and host passing of channel instructions are all supported. The features are configured in firmware. Since the details of some methods are proprietary (e.g. Intel WCS) please contact Bluegiga Technologies for details.

2. ELECTRICAL CHARACTERISTICS

Absolute maximum ratings

	Min	Max	Unit
Storage temperature	-40	85	°C
Operating temperature	-40	85	°C
Supply voltage	-0,3	3,6	V
Terminal voltages	-0,4	Vdd + 0,4	V
Output current from PIOS		35	mA

The module should not continuously run under these conditions. Exposure to absolute maximum rating conditions for extended periods of time may affect reliability and cause permanent damage to the device.

Table 2: Absolute maximum ratings

Recommended operating conditions

	Min	Max	Unit
Operating temperature	-40	85	°C
Supply voltage	3,1 ⁽¹⁾	3,6	V
Terminal voltages	0	Vdd	V

Table 3: Recommended operating conditions

¹⁾ WT12 operates as low as 2,7 V supply voltage. However, to safely meet the USB specification for minimum voltage for USB data lines, minimum of 3,1 V supply is required.

Terminal characteristics

	Min	Typ	Max	Unit
I/O voltage levels				
V _{IL} input logic level low	-0,4	-	0,8	V
V _{IH} input logic level high	0,7Vdd	-	Vdd + 0,4	V
V _{OL} output logic level low	-	-	0,2	V
V _{OH} output logic level high	Vdd - 0,2	-	-	V
Reset terminal				
V _{TH,res} threshold voltage	0,64	0,85	1,5	V
R _{IRES} input resistance		220		kΩ
C _{IRES} input capacitance		220		nF
Input and tri-state current with				
Strong pull-up	-100	-40	-10	μA
Strong pull-down	10	40	100	μA
Weak pull-up	-5	-1	-0,2	μA
Weak pull-down	0,2	1	5	μA
I/O pad leakage current	-1	0	1	μA
Vdd supply current				
TX mode	-	-	70	mA
RX mode	-	-	70	mA

Table 4: Terminal characteristics

Current consumption

Test conditions: Room temperature, Vdd = 3,3 V, iWRAP firmware

OPERATION MODE	Peak supply current	AVG supply current	Unit	Notes
Peak current at TX mode	70	-	mA	-
Peak current at RX mode	70	-	mA	-
IDLE	-	3	mA	Module is idle Default settings
IDLE, Deep Sleep ON	-	1,2	mA	Module is idle
IDLE, Deep Sleep ON NOT visible, NOT connectable	-	0,4	mA	Module is idle (Minimum consumption), SET BT PAGEMODE 0 2000 1
INQUIRY	-	44,7	mA	Device discovery with INQUIRY command
NAME	-	44,7	mA	Name resolution
CALL	-	44,7	mA	CALL [ADDR] 1101 RFCOMM
CONNECT Master	-	6,2	mA	No data was transmitted, Default settings
CONNECT Slave	-	22,4	mA	No data was transmitted, Default settings
CONNECT + Sniff, Master	-	4,7	mA	Connected (SET BT SNIFF 40 20 1 8)
CONNECT + Sniff, Slave	-	4,6	mA	Connected (SET BT SNIFF 40 20 1 8)
CONNECT + sniff, Master	-	2,3	mA	No data transmitted (SET BT SNIFF 1000 20 1 8)
CONNECT + sniff, Slave	-	2,3	mA	No data transmitted (SET BT SNIFF 1000 20 1 8)
CONNECT + park, Master	-	3,1	mA	No data transmittedPark parameter 1000
CONNECT + park, Slave	-	2,3	mA	No data transmittedPark parameter 1000
DATA, Master	-	31,5	mA	Data transmitted @ 115200bps
DATA, Slave	-	29,2	mA	Data transmitted @ 115200bps
DATA + Sniff, Master	-	19,6	mA	Data transmitted @ 115200bps (SET BT SNIFF 40 20 1 8)
DATA + Sniff, Slave	-	22,6	mA	Data transmitted @ 115200bps (SET BT SNIFF 40 20 1 8)
DATA + Sniff, Master	-	3,9	mA	Data transmitted (SET BT SNIFF 1000 20 1 8)

Table 5: Current consumption

Radio characteristics and general specifications

	Specification		Note
Operating frequency range	(2400 ... 2483,5) MHz		ISM Band
Lower guard band	2 MHz		
Upper guard band	3,5 MHz		
Carrier frequency	2402 MHz ... 2480 MHz		$f = 2402 + k$, $k = 0...78$
Modulation method	GFSK (1 Mbps) P/4 DQPSK (2Mbps)		
Hopping	1600 hops/s, 1 MHz channel space		
Maximum data rate	GFSK:	Asynchronous, 723.2 kbps / 57.6 kbps Synchronous: 433.9 kbps / 433.9 kbps	
	P/4 DQPSK:	Asynchronous, 1448.5 kbps / 115.2 kbps Synchronous: 869.7 kbps / 869.7 kbps	
	8DQPSK:	Asynchronous, 2178.1 kbps / 177.2 kbps Synchronous: 1306.9 kbps / 1306.9 kbps	
Receiving signal range	-82 to -20 dBm		Typical condition
Receiver IF frequency	1.5 MHz		Center frequency
Transmission power	Min	-11 ... -9 dBm	
	Max	+1 ... +3 dBm	
RF input impedance	50 Ω		
Compliance	Bluetooth specification, version 2.0 + EDR		
USB specification	USB specification, version 1.1 (USB 2.0 compliant)		

Table 6: Radio characteristics and general specifications

2.1 Radio Characteristics – Basic Data Rate

Transmitter radio characteristics

WT12 meets the Bluetooth v2.0+ EDR specification between -40°C and +85°C. TX output is guaranteed to be unconditionally stable over the guaranteed temperature range.

Measurement conditions: T = 20°C, Vdd = 3,3V

Item	Typical value	Bluetooth specification	Unit
Maximum output power ^{1,2}	+2.5	-6 to 4 ³	dBm
Variation in RF power over temperature range with compensation enabled ⁴	1.5	-	dB
Variation in RF power over temperature range with compensation disabled ⁴	2.0	-	dB
RF power control range	35	≥ 16	dB
RF power range control resolution ⁵	0.5	-	dB
20dB bandwidth for modulated carrier	780	≤ 1000	kHz
Adjacent channel transmit power $F = F_0 \pm 2\text{MHz}$ ^{6,7}	-40	≤ 20	dBm
Adjacent channel transmit power $F = F_0 \pm 3\text{MHz}$ ^{6,7}	-45	≤ -40	dBm
Adjacent channel transmit power $F = F_0 \pm > 3\text{MHz}$ ^{6,7}	-50	≤ -40	dBm
$\Delta f_{1\text{avg}}$ Maximum Modulation	165	$140 < f_{1\text{avg}} < 175$	kHz
$\Delta f_{2\text{max}}$ Maximum Modulation	150	115	kHz
$\Delta f_{1\text{avg}} / \Delta f_{2\text{avg}}$	0.97	≥ 0.80	-
Initial carrier frequency tolerance	6	≤ 75	kHz
Drift Rate	8	≤ 20	kHz/50μs
Drift (single slot packet)	7	≤ 25	kHz
Drift (five slot packet)	9	≤ 40	kHz
2 nd Harmonic content	-65	≤ -30	dBm
3 rd Harmonic content	-45	≤ -30	dBm

Table 7: Transmitter radio characteristics at basic data rate and temperature 20°C

Notes:

1. WT12 firmware maintains the transmit power to be within the Bluetooth v2.0+ EDR specification limits.
2. Measurement made using a PSKEY_LC_MAX_TX_POWER setting corresponds to a PSKEY_LC_POWER_TABLE power table entry of 63.
3. Class 2 RF-transmit power range, Bluetooth v2.0+ EDR specification.
4. To some extent these parameters are dependent on the matching circuit used, and its behavior over temperature. Therefore these parameters may be beyond CSR's direct control.
5. Resolution guaranteed over the range -5dB to -25dB relative to maximum power for TX Level > 20.

6. Measured at F0= 2441MHz.

7. Up to three exceptions are allowed in the Bluetooth v2.0+ EDR specification. WT12s guaranteed to meet the ACP performance as specified by the Bluetooth v2.0+ EDR specification.

	Frequency (GHz)	Typ	Unit	Cellular band
Emitted power in cellular bands measured at the unbalanced port of the balun. Output power 4dBm	0.869 – 0.894 ¹	-145	dBm/kHz	GSM 850
	0.869 – 0.894 ²	-145		CDMA 850
	0.925 – 0.960 ¹	-145		GSM 900
	1.570 – 1.580 ³	-145		GPS
	1.805 – 1.880 ¹	-145		GSM 1800 / DCS 1800
	1.930 – 1.990 ⁴	-145		PSC 1900
	1.930 – 1.990 ¹	-145		GSM 1900
	1.930 – 1.990 ²	-145		CDMA 1900
	2.110 – 2.170 ²	-142		W-CDMA 2000
	2.110 – 2.170 ²	-144		W-CDMA 2000

Table 8: Transmitter radio characteristics at basic data rate and temperature 20°C

Notes:

1. Integrated in 200kHz bandwidth and then normalized to a 1Hz bandwidth.
2. Integrated in 1.2MHz bandwidth and then normalized to a 1Hz bandwidth.
3. Integrated in 1MHz bandwidth. and then normalized to a 1Hz bandwidth.
4. Integrated in 30kHz bandwidth and then normalized to a 1Hz bandwidth.
5. Integrated in 5MHz bandwidth and then normalized to a 1Hz bandwidth.

Receiver radio characteristics

Measurement conditions: T = 20°C, Vdd = 3,3V

	Frequency (GHz)	Typ	Bluetooth specification	Unit
Sensitivity at 0.1% BER for all packet types	2.402	-84	≤ 75	dBm
	2.441	-84		
	2.480	-84		
Maximum received signal at 0.1% BER		10	≥ -20	dBm

Table 9: Receiver radio characteristics at basic data rate and temperature 20°C

	Frequency (GHz)	Typ	Bluetooth specification	Unit
Continuous power required to block Bluetooth reception (for sensitivity of -67dBm with 0.1% BER) measured at the unbalanced port of the balun.	30-2000	TBD	≥ -10	dBm
	2000-2400	TBD	≥ -27	
	2500-3000	TBD	≥ -27	
	3000-3300	TBD	≥ -27	
C/I co-channel		6	≤ 11	dB
Adjacent channel selectivity C/I $F = F_0 + 1\text{MHz}^{1,2}$		-5	≤ 0	dB
Adjacent channel selectivity C/I $F = F_0 - 1\text{MHz}^{1,2}$		-4	≤ 0	dB
Adjacent channel selectivity C/I $F = F_0 + 2\text{MHz}^{1,2}$		-38	≤ -30	dB
Adjacent channel selectivity C/I $F = F_0 - 2\text{MHz}^{1,2}$		-23	≤ -20	dB
Adjacent channel selectivity C/I $F = F_0 + 3\text{MHz}^{1,2}$		-45	≤ -40	dB
Adjacent channel selectivity C/I $F = F_0 - 3\text{MHz}^{1,2}$		-44	≤ -40	dB
Adjacent channel selectivity C/I $F = F_{\text{image}}^{1,2}$		-22	≤ 9	dB
Maximum level of intermodulation interferers ³		-30	≥ -39	dBm
Spurious output level ⁴		TBD	-	dBm/Hz

Table 10: Receiver radio characteristics at basic data rate and temperature 20°C

Notes:

- 1 Up to five exceptions are allowed in the Bluetooth v2.0 + EDR specification. BlueCore4 is guaranteed to meet the C/I performance as specified by the Bluetooth v2.0 + EDR specification.
- 2 Measured at $F = 2441\text{MHz}$
- 3 Measured at $f_1 - f_2 = 5\text{MHz}$. Measurement is performed in accordance with Bluetooth RF test RCV/CA/05/c. i.e. wanted signal at -64dBm
- 4 Measured at the unbalanced port of the balun. Integrated in 100kHz bandwidth and then normalized to 1Hz. Actual figure is typically below TBD dBm/Hz except for peaks of -52dBm in band at 2.4GHz and -80dBm at 3.2GHz

	Frequency (GHz)	Typ	Unit	Cellular band
Emitted power in cellular bands required to block Bluetooth reception (for sensitivity of -67dBm with 0.1% BER) measured at the unbalanced port of the balun.	0.824 – 0.849	2.0	dBm	GSM 850
	0.824 – 0.849	TBD		CDMA
	0.880 – 0.915	5.0		GSM 900
	1.710 – 1.785	4.0		GSM 1800 / DCS 1800
	1.710 – 1.785	3.0		GSM 1900 / PCS 1900
	1.850 – 1.910	TBD		CDMA 1900
	1.920 – 1.980	TBD		W-CDMA 2000
Continuous power in cellular bands required to block Bluetooth reception (for sensitivity of -72dBm with 0.1% BER) measured at the unbalanced port of the balun.	0.824 – 0.849	-10	dBm	GSM 850
	0.824 – 0.849	TBD		CDMA
	0.880 – 0.915	-10		GSM 900
	1.710 – 1.785	-9		GSM 1800 / DCS 1800
	1.850 – 1.910	-9		GSM 1900 / PCS 1900
	1.850 – 1.910	TBD		CDMA 1900
	1.920 – 1.980	TBD		W-CDMA 2000

Table 11: Receiver radio characteristics at basic data rate and temperature 20°C

2.2 Radio Characteristics – Enhanced Data Rate

Transmitter radio characteristics

Measurement conditions: T = 20°C, Vdd = 3,3V

	Typ	Bluetooth specification	Unit	
Maximum output power ¹	+1	-6 to 4 ²	dBm	
Relative transmit power ³	-1	-4 to 1	dB	
Carrier frequency stability ³	3	≤ 10	kHz	
Modulation accuracy ^{3,4}	RMS DEV	-	≤ 13 ⁵	%
	99% DEV	-	≤ 20 ⁵	%
	Peak DEVM	-	≤ 25 ⁵	%

Table 12: Transmitter radio characteristics at enhanced data rate and temperature 20°C

Notes:

Results shown are referenced to input of the RF balun.

- 1 WT12 firmware maintains the transmit power to be within the Bluetooth v2.0+ EDR specification limits
- 2 Class 2 RF transmit power range, Bluetooth v2.0 + EDR specification
- 3 Measurements methods are in accordance with the EDR RF Test Specification v2.0.E.2
- 4 Modulation accuracy utilizes differential error vector magnitude (DEVM) with tracking of the carrier frequency drift.
- 5 The Bluetooth specification values are for 8DPSK modulation (values for the S/4 DQPSK modulation are less stringent)

Receiver radio characteristics

Measurement conditions: T = 20°C, Vdd = 3,3V

	Modulation	Typ	Bluetooth specification	Unit
Sensitivity at 0.1% BER for all packet types ¹	Π/4 DQPSK	-87	≤ -70	dBm
	8DQPSK	-79	≤ -70	
Maximum received signal at 0.1% BER ¹	Π/4 DQPSK	-7	≥ -20	dBm
	8DQPSK	-7	≥ -20	
C/I co-channel at 0.1% BER ¹	Π/4 DQPSK	+11	≤ 13	dB
	8DQPSK	+19	≤ 21	
Adjacent channel selectivity C/I F = F ₀ + 1MHz ^{1,2,3}	Π/4 DQPSK	-8	≤ 0	
	8DQPSK	-2	≤ 5	
Adjacent channel selectivity C/I F = F ₀ - 1MHz ^{1,2,3}	Π/4 DQPSK	-8	≤ 0	
	8DQPSK	-2	≤ 5	
Adjacent channel selectivity C/I F = F ₀ + 2MHz ^{1,2,3}	Π/4 DQPSK	-35	≤ -30	
	8DQPSK	-35	≤ -25	
Adjacent channel selectivity C/I F = F ₀ - 2MHz ^{1,2,3}	Π/4 DQPSK	-23	≤ -20	
	8DQPSK	-19	≤ -13	
Adjacent channel selectivity C/I F = F ₀ + 3MHz ^{1,2,3}	Π/4 DQPSK	-43	≤ -40	
	8DQPSK	-40	≤ -33	
Adjacent channel selectivity C/I F = F ₀ - 5MHz ^{1,2,3}	Π/4 DQPSK	-43	≤ -40	
	8DQPSK	-38	≤ -33	
Adjacent channel selectivity C/I F = F _{Image} ^{1,2,3}	Π/4 DQPSK	-17	≤ -7	
	8DQPSK	-11	≤ 0	

Table 13: Receiver radio characteristics at enhanced data rate and temperature 20°C

Notes:

Results shown are referenced to input of the RF balun

- 1 Measurements methods are in accordance with the EDR RF Test Specification v2.0.E.2
- 2 Up to five exceptions are allowed in EDR RF Test Specification v2.0.E.2. WT12 is guaranteed to meet the C/I performance as specified by the EDR RF Test Specification v2.0.E.2.
- 3 Measured at F₀ = 2405MHz, 2441MHz, 2477MHz

3. WT12 PIN DESCRIPTION

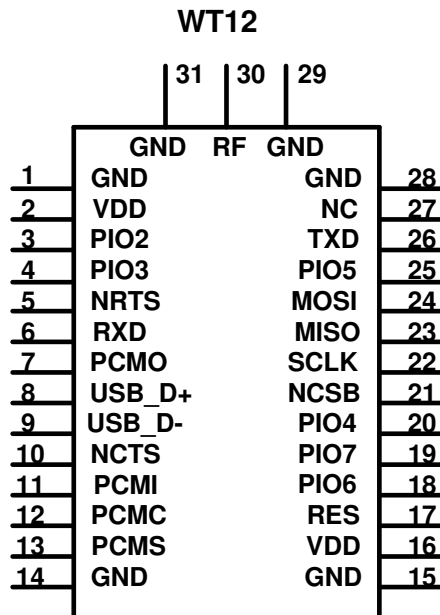

Figure 3: WT12 connection diagram

GND (pins 1, 14, 15, 28, 29 and 31)

Connect GND pins to the ground plane of PCB.

VDD (pins 2 and 16)

3.3 V supply voltage connection. WT12 has an internal decoupling capacitor and LC filter to block high frequency disturbances. Thus external filtering is usually not needed. It is however recommended to leave an option for an external high Q 10pF decoupling capacitor in case EMC problems arise.

RES (pin 17)

The RESET pin is an active high reset and is internally filtered using the internal low frequency clock oscillator. A reset will be performed between 1.5 and 4.0ms following RESET being active. It is recommended that RESET be applied for a period greater than 5ms.

WT12 has an internal reset circuitry, which keeps reset pin active until supply voltage has reached stability in the start up. This ensures that supply for the flash memory inside the WT12 will reach stability before BC4 chip fetches instructions from it. Schematic of the reset circuitry is shown in figure 4. Rising supply voltage charges the capacitor, which will activate the reset of WT12. The capacitor discharges through 220 kΩ resistor, which eventually deactivates the reset. Time constant of the RC circuitry is set such that the supply voltage is safely stabilized before reset deactivates. Pull-up or pull-down resistor should not be connected to the reset pin to ensure proper star up of WT12.

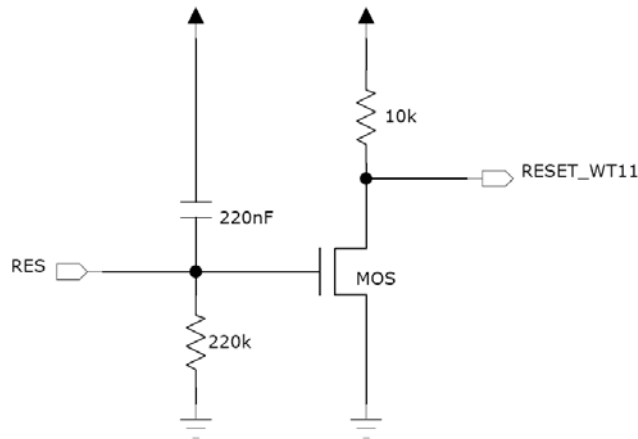

Figure 4: WT12 internal reset circuitry

PIO2 – PIO7 (pins 3, 4, 18, 19, 20 and 25)

Programmable digital I/O lines. All PIO lines can be configured through software to have either weak or strong pull-ups or pull-downs. Configuration for each PIO line depends on the application. See section 10 “I/O parallel ports” for detailed descriptions for each terminal. Default configuration for all of the PIO lines is input with weak internal pull-up.

NC (pin 27)

This pin is internally connected to PIO1.

NRTS (pin 5)

CMOS output with weak internal pull-up. Can be used to implement RS232 hardware flow control where RTS (request to send) is active low indicator. UART interface requires external RS232 transceiver chip.

NCTS (pin 10)

CMOS input with weak internal pull-down. Can be used to implement RS232 hardware flow control where CTS (clear to send) is active low indicator. UART interface requires external RS232 transceiver chip.

RXD (pin 6)

CMOS input with weak internal pull-down. RXD is used to implement UART data transfer from another device to WT12. UART interface requires external RS232 transceiver chip.

TXD (pin 26)

CMOS output with weak internal pull-up. TXD is used to implement UART data transfer from WT12 to another device. UART interface requires external RS232 transceiver chip.

PCMO (pin 7)

CMOS output with weak internal pull-down. Used in PCM (pulse code modulation) interface to transmit digitized audio.

PCMI (pin 11)

CMOS input with weak internal pull-down. Used in PCM interface to receive digitized audio.

PCMC (pin 12)

Bi-directional synchronous data clock signal pin with weak internal pull-down. PCMC is used in PCM interface to transmit or receive CLK signal. When configured as a master, WT12 generates clock signal for the PCM interface. When configured as a slave PCMC is an input and receives the clock signal from another device.

PCMS (pin 13)

Bi-directional synchronous data strobe with weak internal pull-down. When configured as a master, WT12 generates SYNC signal for the PCM interface. When configured as a slave PCMS is an input and receives the SYNC signal from another device.

USB_D+ (pin 8)

Bi-directional USB data line with a selectable internal 1.5 k Ω pull-up implemented as a current source (compliant with USB specification v1.2) External series resistor is required to match the connection to the characteristic impedance of the USB cable.

USB_D- (pin 9)

Bi-directional USB data line. External series resistor is required to match the connection to the characteristic impedance of the USB cable.

NCSB (pin 21)

CMOS input with weak internal pull-up. Active low chip select for SPI (serial peripheral interface).

SCLK (pin 22)

CMOS input for the SPI clock signal with weak internal pull-down. WT12 is the slave and receives the clock signal from the device operating as a master.

MISO (pin 23)

SPI data output with weak internal pull-down.

MOSI (pin 24)

SPI data input with weak internal pull-down.

RF (pin 30)

Connect external RF-transceiver antenna to this pin when chip antenna is not in use.

4. PHYSICAL INTERFACES

4.1 UART Interface

WT12 Universal Asynchronous Receiver Transmitter (UART) interface provides a simple mechanism for communicating with other serial devices using the RS232 standard. The UART interface of WT12 uses voltage levels of 0 to V_{dd} and thus external transceiver IC is required to meet the voltage level specifications of UART.

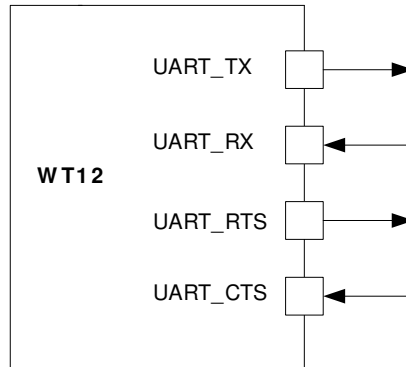

Figure 5: WT12 UART interface

Four signals are used to implement the UART function, as shown in Figure 6. When WT12 is connected to another digital device, UART_RX and UART_TX transfer data between the two devices. The remaining two signals, UART_CTS and UART_RTS, can be used to implement RS232 hardware flow control where both are active low indicators. DTR, DSR and DCD signals can be implemented using PIO terminals of WT12. All UART connections are implemented using CMOS technology and have signaling levels of 0V and V_{DD}.

In order to communicate with the UART at its maximum data rate using a standard PC, an accelerated serial port adapter card is required for the PC.

Parameter		Possible values
Baud rate	Minimum	1200 baud (d2%Error)
	Maximum	9600 baud (d1%Error)
Flow control		RTS/CTS, none
Parity		None, Odd, Even
Number of stop bits		1 or 2
Bits per channel		8

Table 14: Possible UART settings

The UART interface is capable of resetting WT12 upon reception of a break signal. A Break is identified by a continuous logic low (0V) on the UART_RX terminal, as shown in Figure 7. If t_{BRK} is longer than the value, defined by the PS Key PSKEY_HOST_IO_UART_RESET_TIMEOUT, (0x1a4), a reset will occur. This feature allows a host to initialize the system to a known state. Also, WT12 can emit a Break character that may be used to wake the Host.

Since UART_RX terminal includes weak internal pull-down, it can't be left open unless disabling UART interface using PS_KEY settings. If UART is not disabled, a pull-up resistor

has to be connected to UART_RX. UART interface requires external RS232 transceiver, which usually includes the required pull-up.

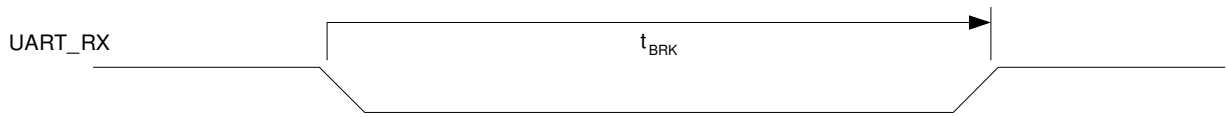

Figure 6: Break signal

Note:

Table 15 shows a list of commonly used Baud rates and their associated values for the Persistent Store Key PSKEY_UART_BAUD_RATE (0x204). There is no requirement to use these standard values. Any Baud rate within the supported range can be set in the Persistent Store Key according to the formula in Equation below.

$$\text{Baud Rate} = \frac{\text{PSKEY_UART_BAUD_RATE}}{0.004096}$$

Figure 7: Baud rate calculation formula

Baud rate	Persistent store values		Error
	Hex	Dec	
1200	0x0005	5	1.73%
2400	0x000a	10	1.73%
4800	0x0014	20	1.73%
9600	0x0027	39	-0.82%
19200	0x004f	79	0.45%
38400	0x009d	157	-0.18%
57600	0x00ec	263	0.03%
76800	0x013b	315	0.14%
115200	0x01d8	472	0.03%
230400	0x03b0	944	0.03%
460800	0x075f	1887	-0.02%
921600	0x0ebf	3775	0.00%
1382400	0x161e	5662	-0.01%
1843200	0x1d7e	7550	0.00%
2765800	0x2c3d	11325	0.00%

Table 15: UART baud rates and error values

4.1.1 UART Configuration While RESET is Active

The UART interface for WT12 while the chip is being held in reset is tri-state. This will allow the user to daisy chain devices onto the physical UART bus. The constraint on this method is that any devices connected to this bus must tri-state when WT12reset is de-asserted and the firmware begins to run.

4.1.2 UART Bypass Mode

Alternatively, for devices that do not tri-state the UART bus, the UART bypass mode on WT12 can be used. The default state of WT12 after reset is de-asserted, this is for the host

UART bus to be connected to the WT12 UART, thereby allowing communication to WT12 via the UART.

In order to apply the UART bypass mode, a BCCMD command will be issued to WT12 upon this, it will switch the bypass to PIO[7:4] as shown in Figure 9. Once the bypass mode has been invoked, WT12 will enter the deep sleep state indefinitely.

In order to re-establish communication with WT12, the chip must be reset so that the default configuration takes affect.

It is important for the host to ensure a clean Bluetooth disconnection of any active links before the bypass mode is invoked. Therefore it is not possible to have active Bluetooth links while operating the bypass mode.

The current consumption for a device in UART Bypass Mode is equal to the values quoted for a device in standby mode.

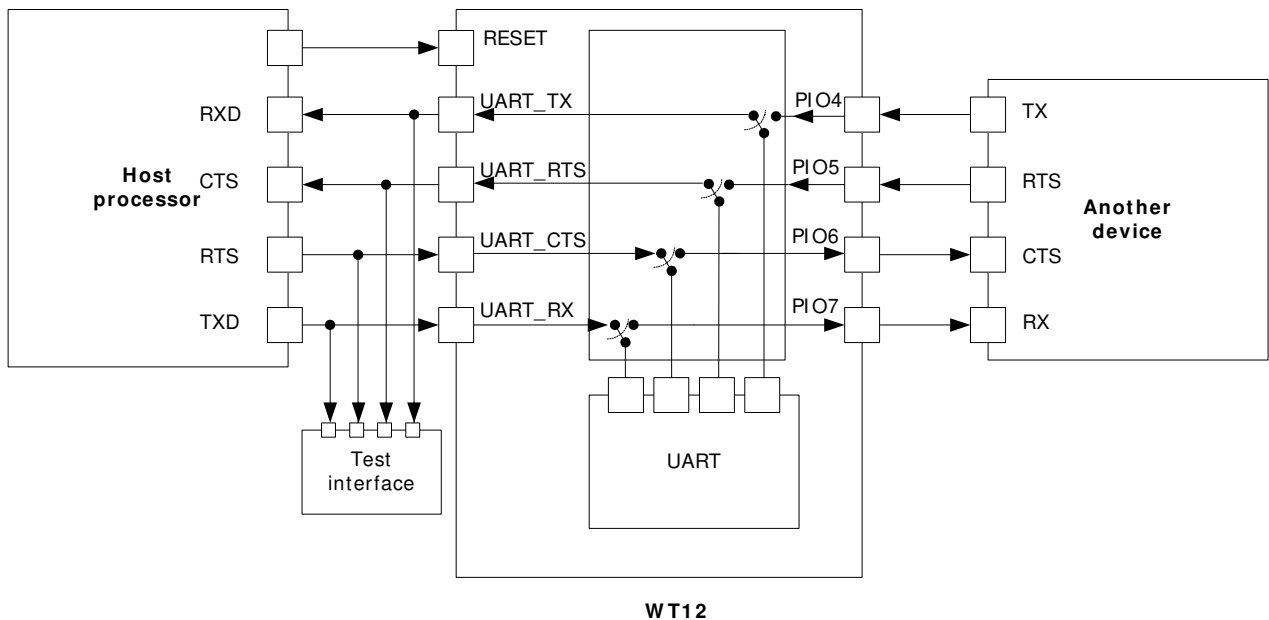

Figure 8: UART bypass mode

4.2 USB Interface

WT12 USB devices contain a full speed (12Mbps/s) USB interface that is capable of driving a USB cable directly. No external USB transceiver is required. To match the connection to the characteristic impedance of the USB cable, series resistors must be included to both of the signal lines. These should be of 1% tolerance and the value required may vary between 0 and 20 ohm with 10 ohm being nominal. The resistors should be placed close to the USB pins of the module in order to avoid reflections. The module has internally 22 ohm resistors in series. The total input impedance seen by the cable is affected by the IC characteristics, track layout and the connector. The cable impedance is approximately 40 ohm.

The device operates as a USB peripheral, responding to requests from a master host controller such as a PC. Both the OHCI and the UHCI standards are supported. The set of USB endpoints implemented can behave as specified in the USB section of the Bluetooth v2.0 + EDR specification or alternatively can appear as a set of endpoint appropriate to USB audio devices such as speakers.

As USB is a Master/Slave oriented system (in common with other USB peripherals), WT12 only supports USB Slave operation.

4.2.1 USB Pull-Up Resistor

WT12 features an internal USB pull-up resistor. This pulls the USB_DP pin weakly high when WT12 is ready to enumerate. It signals to the PC that it is a full speed (12Mbit/s) USB device.

The USB internal pull-up is implemented as a current source, and is compliant with Section 7.1.5 of the USB specification v1.2. The internal pull-up pulls USB_D+ high to at least 2.8V when loaded with a 15k Ω +/-5% pull-down resistor (in the hub/host). This presents a Therein resistance to the host of at least 900 Ω . Alternatively, an external 1.5k Ω pull-up resistor can be placed between a PIO line and D+ on the USB cable. The firmware must be alerted to which mode is used by setting PS Key PSKEY_USB_PIO_PULLUP appropriately. The default setting uses the internal pull-up resistor.

4.2.2 Self Powered Mode

In self powered mode, the circuit is powered from its own power supply and not from the VBUS (5V) line of the USB cable. It draws only a small leakage current (below 0.5mA) from VBUS on the USB cable. This is the easier mode for which to design for, as the design is not limited by the power that can be drawn from the USB hub or root port. However, it requires that VBUS be connected to WT12 via a voltage divider (Rvb1 and Rvb2), so WT12 can detect when VBUS is powered up. Voltage divider is essential to drop the 5V voltage at the VBUS to 3,3V expected at the USB interface of WT12. WT12 will not pull USB_DP high when VBUS is off.

Self powered USB designs (powered from a battery or PSU) must ensure that a PIO line is allocated for USB pull-up purposes. A 1.5K 5% pull-up resistor between USB_DP and the selected PIO line should be fitted to the design. Failure to fit this resistor may result in the design failing to be USB compliant in self powered mode. The internal pull-up in WT12 is only suitable for bus powered USB devices i.e. dongles.

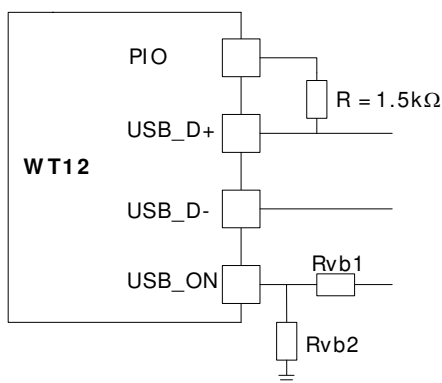

Figure 9: USB in self powered mode

The terminal marked USB_ON can be any free PIO pin. The PIO pin selected must be registered by setting PSKEY_USB_PIO_VBUS to the corresponding pin number. In self powered mode PSKEY_USB_PIO_PULLUP must be set to match with the PIO selected.

Note:

USB_ON is shared with WT12 PIO terminals (PIO2-PIO7).

4.2.3 Bus Powered Mode

In bus powered mode the application circuit draws its current from the 5V VBUS supply on the USB cable. WT12 negotiates with the PC during the USB enumeration stage about how much current it is allowed to consume.

For WT12 Bluetooth applications, it is recommended that the regulator used to derive 3.3V from VBUS is rated at 100mA average current and should be able to handle peaks of 120mA without fold back or limiting. In bus powered mode, WT12 requests 100mA during enumeration.

When selecting a regulator, be aware that VBUS may go as low as 4.4V. The inrush current (when charging reservoir and supply decoupling capacitors) is limited by the USB specification (see USB specification v1.1, Section 7.2.4.1). Some applications may require soft start circuitry to limit inrush current if more than 10pF is present between VBUS and GND.

The 5V VBUS line emerging from a PC is often electrically noisy. As well as regulation down to 3.3V, applications should include careful filtering of the 5V line to attenuate noise that is above the voltage regulator bandwidth.

In bus powered mode PSKEY_USB_PIO_PULLUP must be set to 16 for internal pull-up (default configuration in WT12).

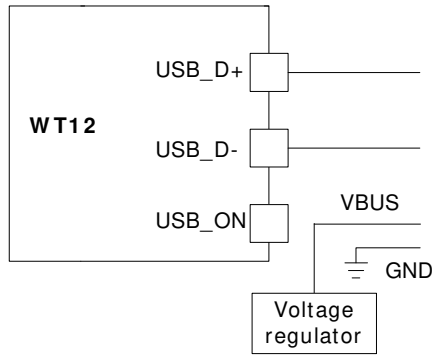

Figure 10: USB in bus powered mode

4.2.4 Suspend Current

All USB devices must permit the USB controller to place them in a USB Suspend mode. While in USB Suspend, bus powered devices must not draw more than 0.5mA from USB VBUS (self powered devices may draw more than 0.5mA from their own supply). This current draw requirement prevents operation of the radio by bus powered devices during USB Suspend.

The voltage regulator circuit itself should draw only a small quiescent current (typically less than 100uA) to ensure adherence to the suspend current requirement of the USB specification. This is not normally a problem with modern regulators. Ensure that external LEDs and/or amplifiers can be turned off by WT12. The entire circuit must be able to enter the suspend mode. (For more details on USB Suspend, see separate CSR documentation).

4.2.5 Detach and Wake-Up Signaling

WT12 can provide out-of-band signaling to a host controller by using the control lines called 'USB_DETACH' and 'USB_WAKE_UP'. These are outside the USB specification (no wires exist for them inside the USB cable), but can be useful when embedding WT12 into a circuit where no external USB is visible to the user. Both control lines are shared with PIO pins and can be assigned to any PIO pin by setting the PS Keys PSKEY_USB_PIO_DETACH and PSKEY_USB_PIO_WAKEUP to the selected PIO number.

USB_DETACH is an input which, when asserted high, causes WT12 to put USB_D- and USB_D+ in high impedance state and turned off the pull-up resistor on D+. This detaches the device from the bus and is logically equivalent to unplugging the device. When USB_DETACH is taken low, WT12 will connect back to USB and await enumeration by the USB host.

USB_WAKE_UP is an active high output (used only when USB_DETACH is active) to wake up the host and allow USB communication to recommence. It replaces the function of the software USB_WAKE_UP message (which runs over the USB cable), and cannot be sent while WT12 is effectively disconnected from the bus.