



Chipsmall Limited consists of a professional team with an average of over 10 year of expertise in the distribution of electronic components. Based in Hongkong, we have already established firm and mutual-benefit business relationships with customers from,Europe,America and south Asia,supplying obsolete and hard-to-find components to meet their specific needs.

With the principle of “Quality Parts,Customers Priority,Honest Operation,and Considerate Service”,our business mainly focus on the distribution of electronic components. Line cards we deal with include Microchip,ALPS,ROHM,Xilinx,Pulse,ON,Everlight and Freescale. Main products comprise IC,Modules,Potentiometer,IC Socket,Relay,Connector.Our parts cover such applications as commercial,industrial, and automotives areas.

We are looking forward to setting up business relationship with you and hope to provide you with the best service and solution. Let us make a better world for our industry!



Contact us

Tel: +86-755-8981 8866 Fax: +86-755-8427 6832

Email & Skype: info@chipsmall.com Web: www.chipsmall.com

Address: A1208, Overseas Decoration Building, #122 Zhenhua RD., Futian, Shenzhen, China



Getting started with the X-NUCLEO-IHM07M1 motor driver expansion board based on the L6230 for STM32 Nucleo

Introduction

The X-NUCLEO-IHM07M1 is a three-phase brushless DC motor driver expansion board based on the L6230 for STM32 Nucleo. It provides an affordable and easy-to-use solution for driving three-phase brushless DC motors in your STM32 Nucleo project. The X-NUCLEO-IHM07M1 is compatible with the ST morpho connector and supports the addition of other boards which can be stacked onto a single STM32 Nucleo board. The user can also mount the Arduino UNO R3 connector. The X-NUCLEO-IHM07M1 is fully configurable and ready to support different closed loop control based on sensor or sensorless mode control, and it is compatible with three shunt or single shunt current sense measuring. The driver used on this STM32 Nucleo expansion board is the L6230, a DMOS fully-integrated driver for three-phase brushless PMSM motors, assembled in a PowerSO36 package, with overcurrent and thermal protection. This user manual describes the procedure to configure the X-NUCLEO-IHM07M1 expansion board to operate with an STM32 Nucleo board.

Figure 1: X-NUCLEO-IHM07M1 three-phase brushless DC motor driver expansion board based on L6230 for STM32 Nucleo

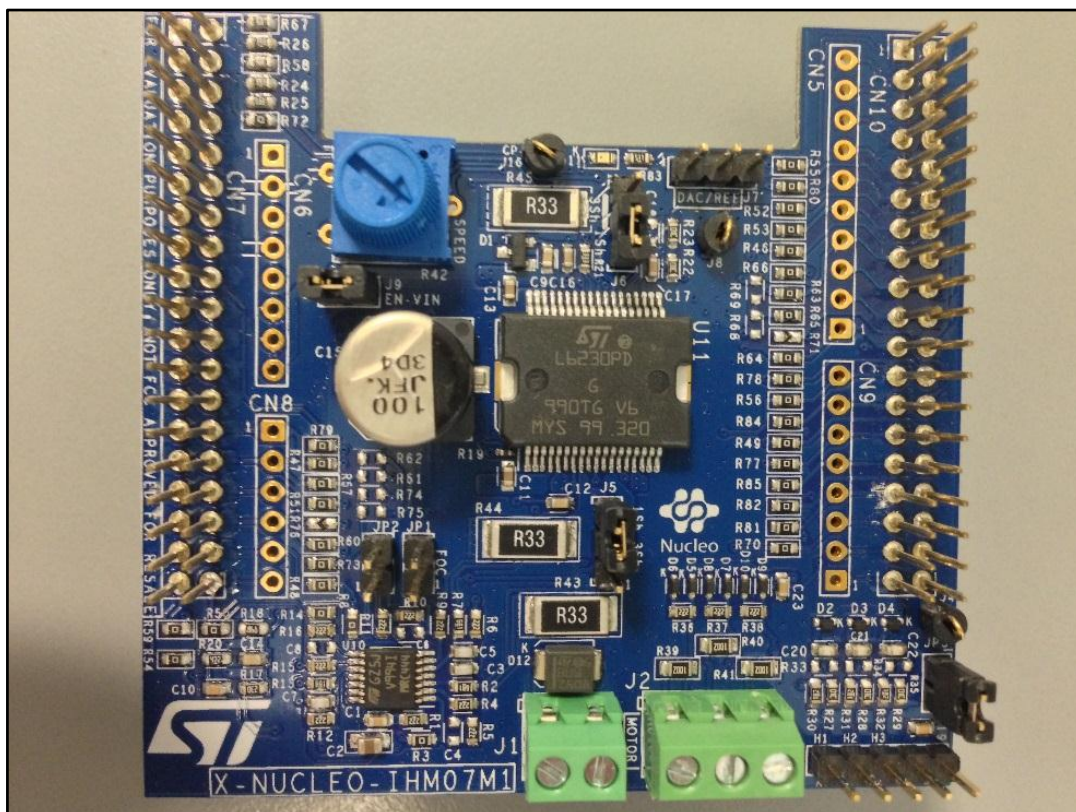

Contents

1	System introduction	3
1.1	Main characteristics	3
1.2	Target applications.....	3
2	Getting started	4
2.1	System architecture	4
2.2	Building the system	4
2.2.1	Hardware settings.....	5
3	Board schematic	10
4	Circuit description	18
4.1	Power section – L6230 driver with integrated three-phase bridge... 18	
4.2	Power section – Overcurrent detection (OCP) and current sensing measurement	19
4.3	Analog section – Hall/Encoder motor speed sensor.....	21
4.4	Analog section – BEMF detection circuit.....	21
4.5	Analog section – Bus voltage and temperature sensing circuit	21
5	BOM (bill of material)	23
6	Revision history	27

1 System introduction

1.1 Main characteristics

The list below provides the board specification data and the main parameters for the X-NUCLEO-IHM07M1 expansion board:

- Three-phase driver board for BLDC/PMSM motors
- Nominal operating voltage range from 8 V to 48 V DC
- 2.8 A output peak current (1.4 A_{RMS})
- Operating frequency up to 100 kHz
- Non dissipative overcurrent detection and protection
- Cross-conduction protection
- Thermal measuring and overheating protection
- Full compatibility with ST Six Step or ST FOC control algorithms
- Full support for sensor and sensorless mode
- 3-shunt and 1-shunt configurable jumpers for motor current sensing
- Hall/Encoder motor sensor connector and circuit
- Debug connector for DAC, GPIOs, etc.
- Potentiometer available for speed regulation
- Fully populated board conception with test points
- User LED
- Compatible with STM32 Nucleo boards
- Equipped with ST morpho connectors
- RoHS compliant
- PCB type and size:
 - PCB material: FR-4
 - 4-layer layout
 - Copper thickness: 70 µm (external layer), 35 µm (internal layer)
 - Total dimensions of the board: 70 mm x 66 mm

1.2 Target applications

- Low voltage PMSM motor driver
- Low power fans
- Power tools
- Industrial drives

2 Getting started

2.1 System architecture

A generic motor control system can be schematized in three main blocks (see [Figure 2: "Overall system architecture"](#)):

- **Control block** - its main task is to accept user commands and drive a motor. The X-NUCLEO-IHM07M1 is based on the STM32 Nucleo board, which provides all digital signals to properly implement motor driver control.
- **Power block** - it is based on three-phase inverter topology. The core of the power block is the L6230 driver, which contains all the necessary active power and analog components to perform low voltage PMSM motor control.
- **Motor** - the X-NUCLEO-IHM07M1 is able to properly drive a low voltage BLDC/PMSM motor.

Figure 2: Overall system architecture

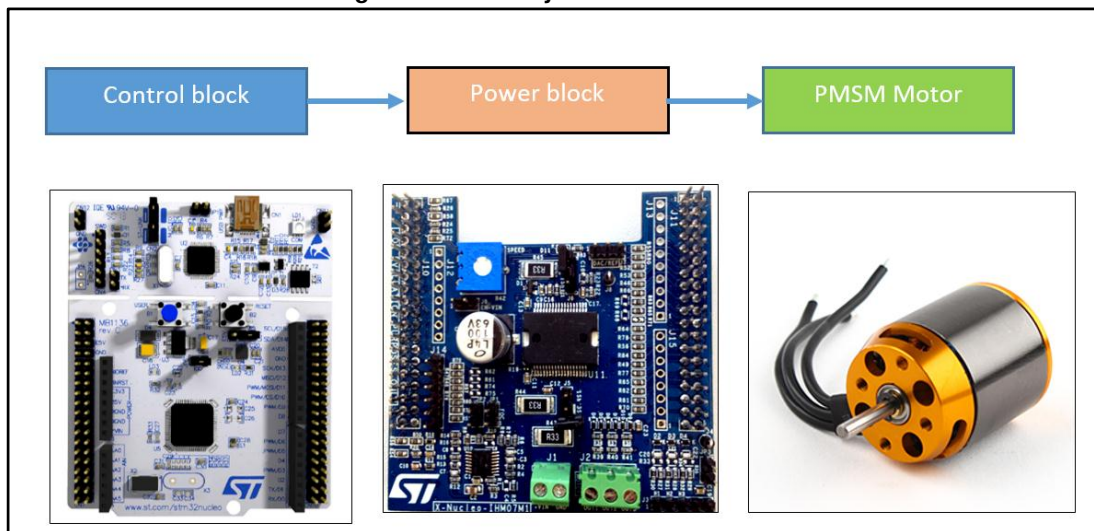

2.2 Building the system

The X-NUCLEO-IHM07M1 expansion board is a complete hardware development platform (Power block) for the STM32 Nucleo board, for evaluating a motor control solution for a single BLDC/PMSM motor. For normal board operation, it must be connected to an STM32 Nucleo board (Control block) through the ST morpho connector, as shown in the image below.

Figure 3: X-NUCLEO-IHM07M1 plugged on STM32 Nucleo

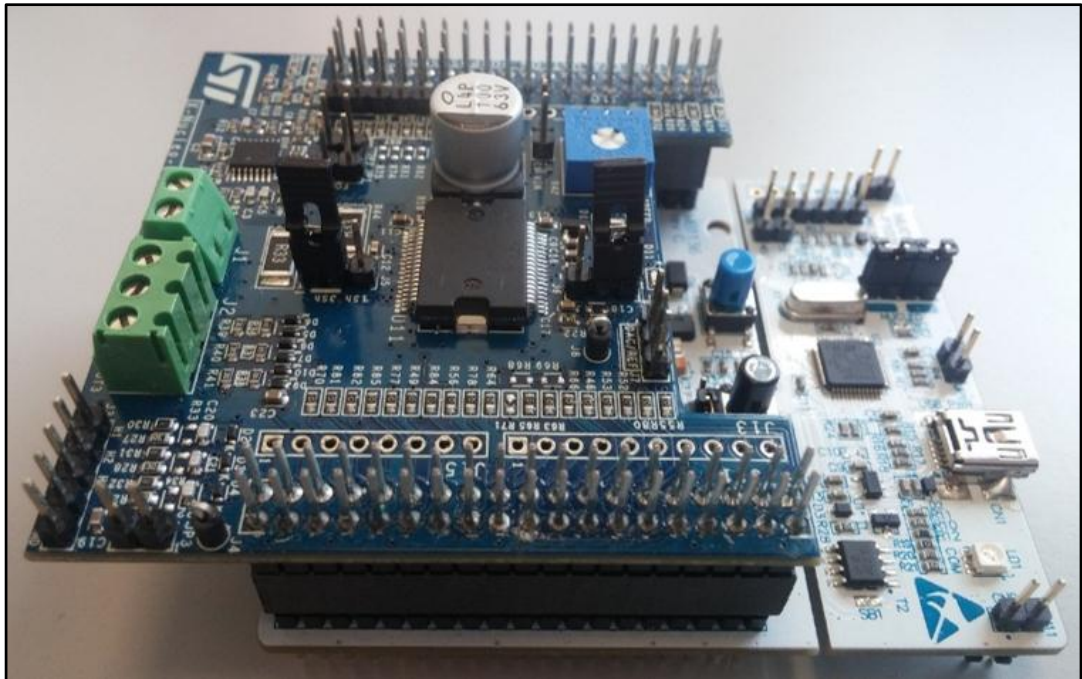

The interconnection between the STM32 Nucleo and the X-NUCLEO-IHM07M1 has been designed for full-compatibility with many STM32 Nucleo boards and no solder bridge modification is required. When stacked, the system is ready to operate with the connection of a BLDC/PMSM motor. For proper use, please respect the hardware and software settings. For the software details, refer to the X-CUBE-SPN7 software expansion documents available on www.st.com.

2.2.1 Hardware settings

Table 1: Jumper settings

Jumper	Permitted configurations	Default condition
JP1	Selection for pull-up insertion (BIAS) in current sensing circuit	OPEN
JP2	Selection for op amp gain modification in current sensing circuit	OPEN
JP3	Selection for pull-up enabling in Hall/Encoder detection circuit	CLOSED
J9	Selection to supply the STM32 Nucleo board through the X-NUCLEO-IHM07M ⁽¹⁾	OPEN
J5	Selection for single/three shunt configuration. Set to single shunt by default	2-3 CLOSED
J6	Selection for single/three shunt configuration. Set to single shunt by default	2-3 CLOSED
J7	Debug connector for DAC. Available for probe connection	OPEN

Notes:

⁽¹⁾It is recommended to REMOVE jumper J9 before power-on on J1

With J9 closed, it is mandatory not to exceed 12 V DC on the J1 connector to avoid damage to the STM32 Nucleo board.

Jumper JP5 (STM32 Nucleo board) MUST be connected between pin 2 and 3 to enable the STM32 Nucleo external power supply.

Table 2: Screw terminal table

Screw terminal	Function
J1	Motor power supply input (8 V- 48 V DC)
J2	3-phase motor connector

Figure 4: X-NUCLEO-IHM07M1 – top layer with silk-screen

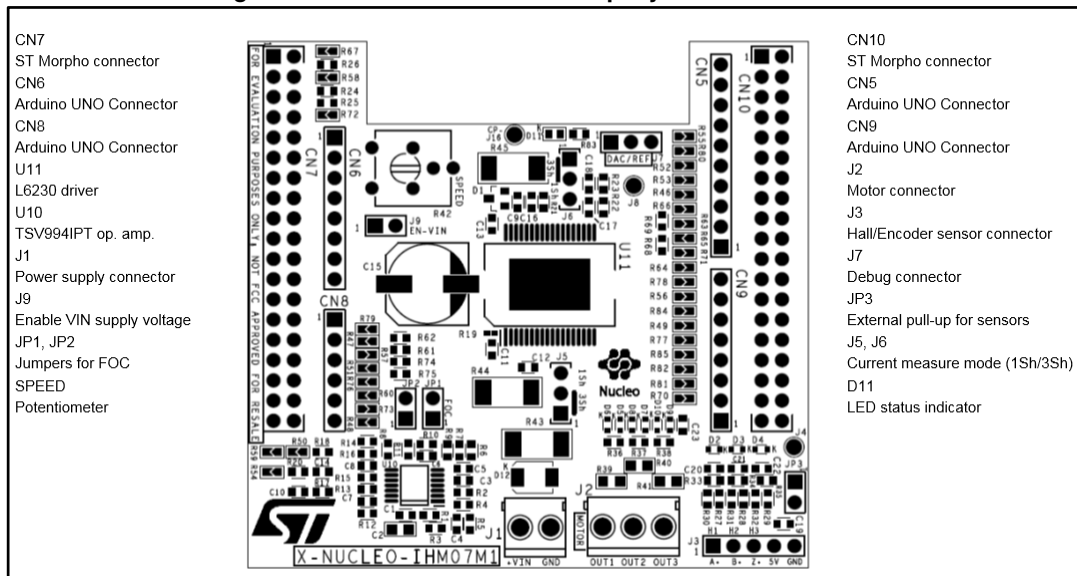

The X-NUCLEO-IHM07M1 expansion board is equipped with the ST morpho connector, male pin headers (CN7 and CN10) accessible on both sides of the board. They can be used to connect the power board to the STM32 Nucleo board. All signals and power pins of the MCU are available on the ST morpho connector. For further details, please refer to user manual UM1724 (5.12 STMicroelectronics morpho connector) available on www.st.com.

Table 3: ST morpho connector table

Connector	Pin	Default	Signal	Solder bridge
CN7	1	PC10	Enable_CH1-L6230	R58
	2	PC11	Enable_CH2-L6230	R67
	3	PC12	Enable_CH3-L6230	R72
	4	PD2		
	5	VDD		
	6	E5V		
	7	BOOT0		
	8	GND		
	9	NC/PF6		

Connector	Pin	Default	Signal	Solder bridge
	10	NC		
	11	NC/PF7		
	12	IOREF		
	13	PA13		
	14	RESET		
	15	PA14		
	16	+3V3		
	17	PA15	Encoder A/Hall H1	R79
	18	+5V	Encoder/Hall PS voltage	
	19	GND		
	20	GND		
	21	PB7		
	22	GND		
	23	PC13	Blue button	
	24	VIN		J9
	25	PC14		
	26	NC		
	27	PC15		
	28	PA0	Curr_fdbk_PhA	R47
	29	PH0/PF0/PD0		
	30	PA1	VBUS_sensing	R51
	31	PH1/PF1/PD1		
	32	PA4	DAC_Ch	R76 N.M.
	33	VLCD/VBAT		
	34	PB0	BEMF2_sensing	R60
	35	PC2	Temperature feedback	R54
	36	PC1 or PB9 ⁽¹⁾	Curr_fdbk_PhB	R48
	37	PC3	BEMF1_sensing	R59
	38	PC0 or PB8 ⁽²⁾	Curr_fdbk_PhC	R50
CN10	1	PC9		
	2	PC8		
	3	PB8		
	4	PC6		
	5	PB9		
	6	PC5		
	7	AVDD		
	8	U5V ⁽³⁾		

Connector	Pin	Default	Signal	Solder bridge
	9	GND		
	10	NC		
	11	PA5 ⁽⁴⁾	GPIO/DAC/PWM	R80
	12	PA12	CPOUT	R52
	13	PA6 ⁽⁵⁾	DIAG/ENABLE/BKIN1	R53
	14	PA11	DIAG/ENABLE/BKIN2	R46
	15	PA7 ⁽⁶⁾	BEMF3_sensing	R63
	16	PB12		
	17	PB6		
	18	PB11/NC		
	19	PC7		
	20	GND		
	21	PA9	VH_PWM	R64
	22	PB2	LED RED	R83
	23	PA8	UH_PWM	R56
	24	PB1	POTENTIOMETER	R78
	25	PB10	Encoder Z/Hall H3	R84
	26	PB15 ⁽⁷⁾	BEMF3_sensing	R66
	27	PB4	CURRENT REF	R77
	28	PB14 ⁽⁸⁾	DIAG/ENABLE/BKIN1	R49
	29	PB5	GPIO/DAC/PWM	R85
	30	PB13 ⁽⁹⁾	GPIO/DAC/PWM	R82
	31	PB3	Encoder B/Hall H2	R81
	32	AGND		
	33	PA10	WH_PWM	R70
	34	PC4		
	35	PA2		
	36	NC/PF5		
	37	PA3		
	38	NC/PF4		

Notes:

(1) Please refer to Table 9: Solder bridges in user manual UM1724 for further details

(2) Please refer to Table 9: Solder bridges in user manual UM1724 for further details

(3) U5V is 5 V power from ST-LINK/V2-1 USB connector and it rises before +5 V

(4) For STM32F302-Nucleo only:

- pin PA5 is on CN10/pin 30 and PB13 is on CN10/pin 11
- pin PA6 is on CN10/pin 28 and PB14 is on CN10/pin 13
- pin PA7 is on CN10/pin 26 and PB15 is on CN10/pin 13

⁽⁵⁾For STM32F302-Nucleo only:

- pin PA5 is on CN10/pin 30 and PB13 is on CN10/pin 11
- pin PA6 is on CN10/pin 28 and PB14 is on CN10/pin 13
- pin PA7 is on CN10/pin 26 and PB15 is on CN10/pin 13

⁽⁶⁾For STM32F302-Nucleo only:

- pin PA5 is on CN10/pin 30 and PB13 is on CN10/pin 11
- pin PA6 is on CN10/pin 28 and PB14 is on CN10/pin 13
- pin PA7 is on CN10/pin 26 and PB15 is on CN10/pin 13

⁽⁷⁾For STM32F302-Nucleo only:

- pin PA5 is on CN10/pin 30 and PB13 is on CN10/pin 11
- pin PA6 is on CN10/pin 28 and PB14 is on CN10/pin 13
- pin PA7 is on CN10/pin 26 and PB15 is on CN10/pin 13

⁽⁸⁾For STM32F302-Nucleo only:

- pin PA5 is on CN10/pin 30 and PB13 is on CN10/pin 11
- pin PA6 is on CN10/pin 28 and PB14 is on CN10/pin 13
- pin PA7 is on CN10/pin 26 and PB15 is on CN10/pin 13

⁽⁹⁾For STM32F302-Nucleo only:

- pin PA5 is on CN10/pin 30 and PB13 is on CN10/pin 11
- pin PA6 is on CN10/pin 28 and PB14 is on CN10/pin 13
- pin PA7 is on CN10/pin 26 and PB15 is on CN10/pin 13

3 Board schematic

Figure 5: X-NUCLEO-IHM07M1 schematic (1 of 8)

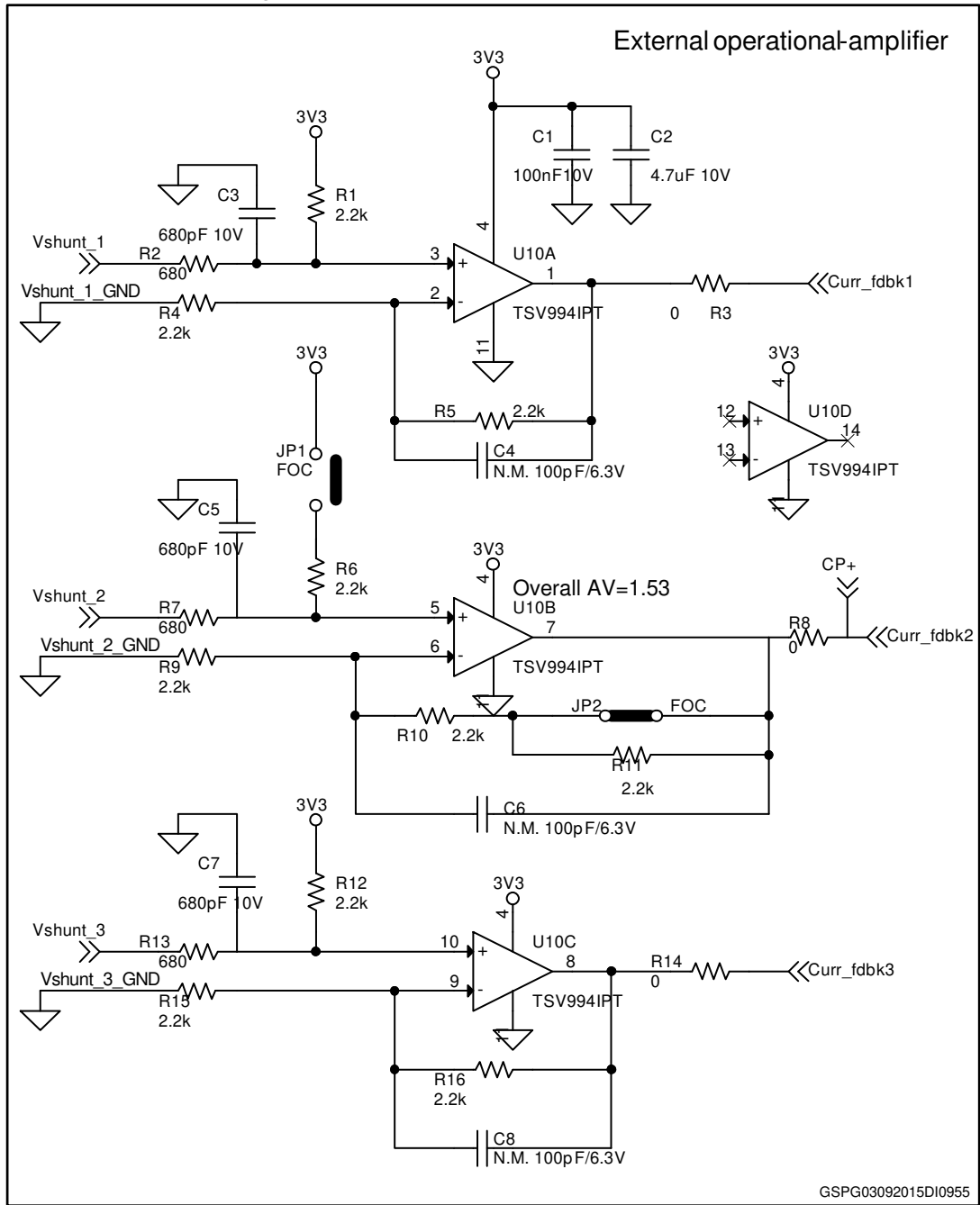
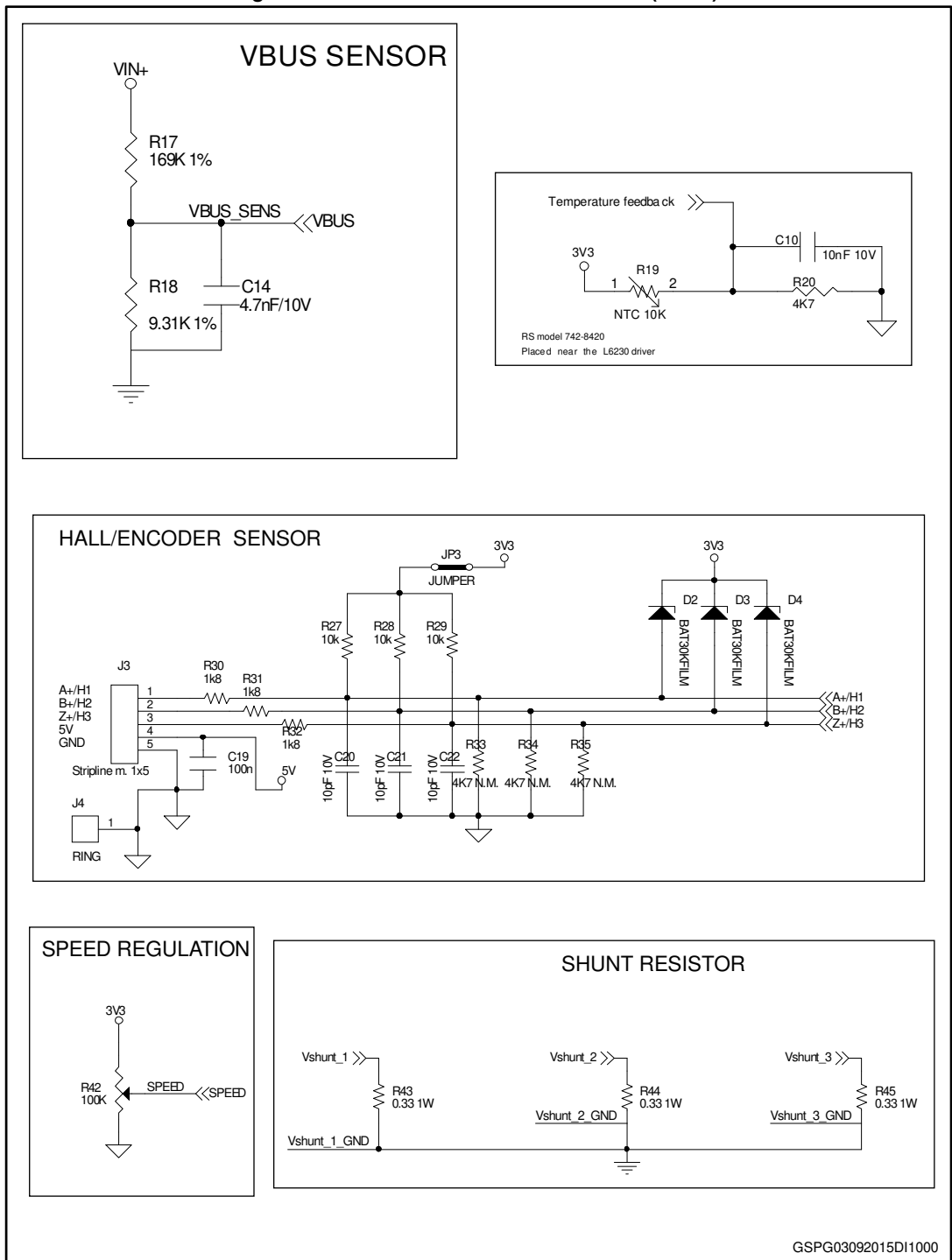
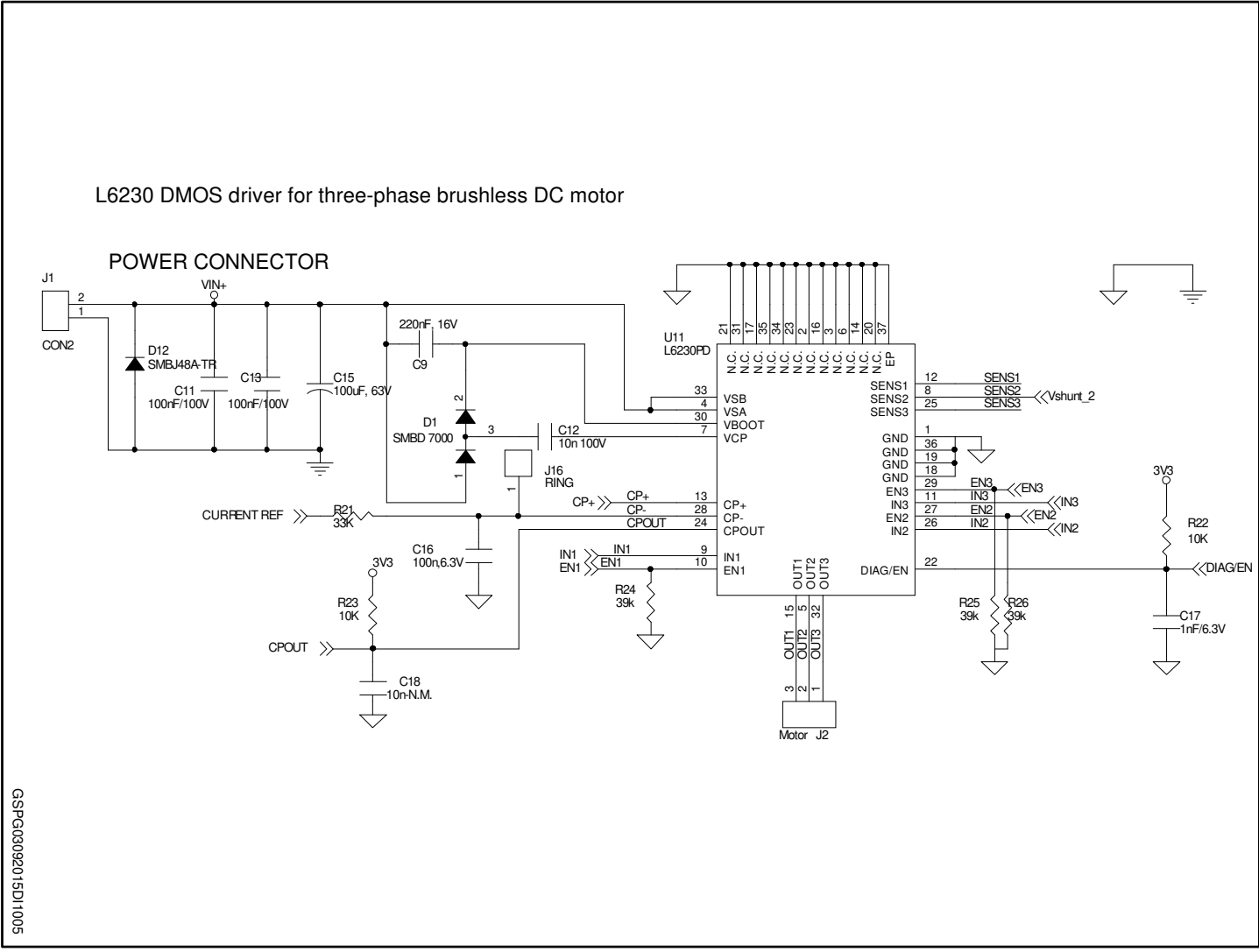

Figure 6: X-NUCLEO-IHM07M1 schematic (2 of 8)



GSPG03092015DI1000

Figure 7: X-NUCLEO-IHM07M1 schematic (3 of 8)



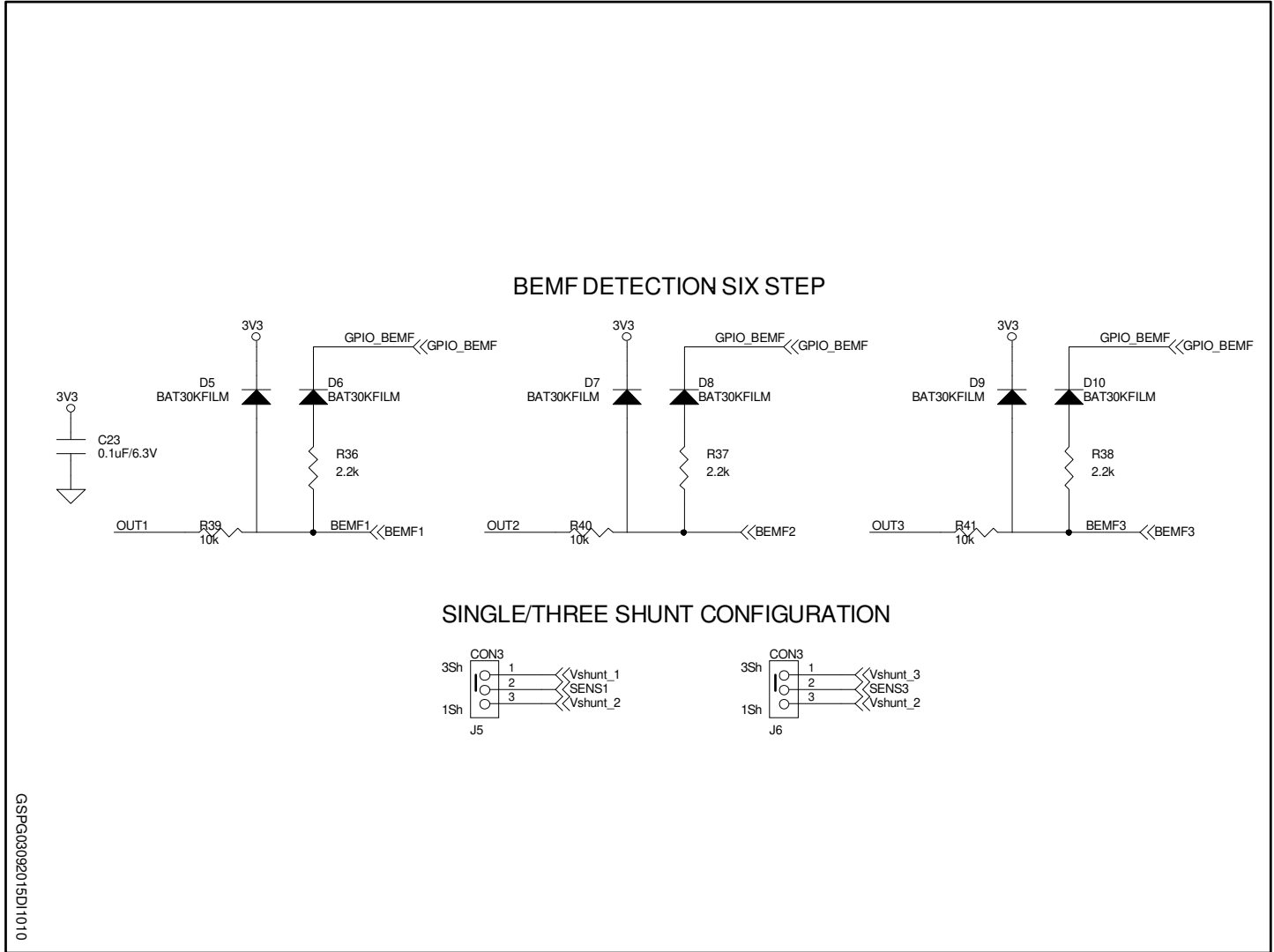
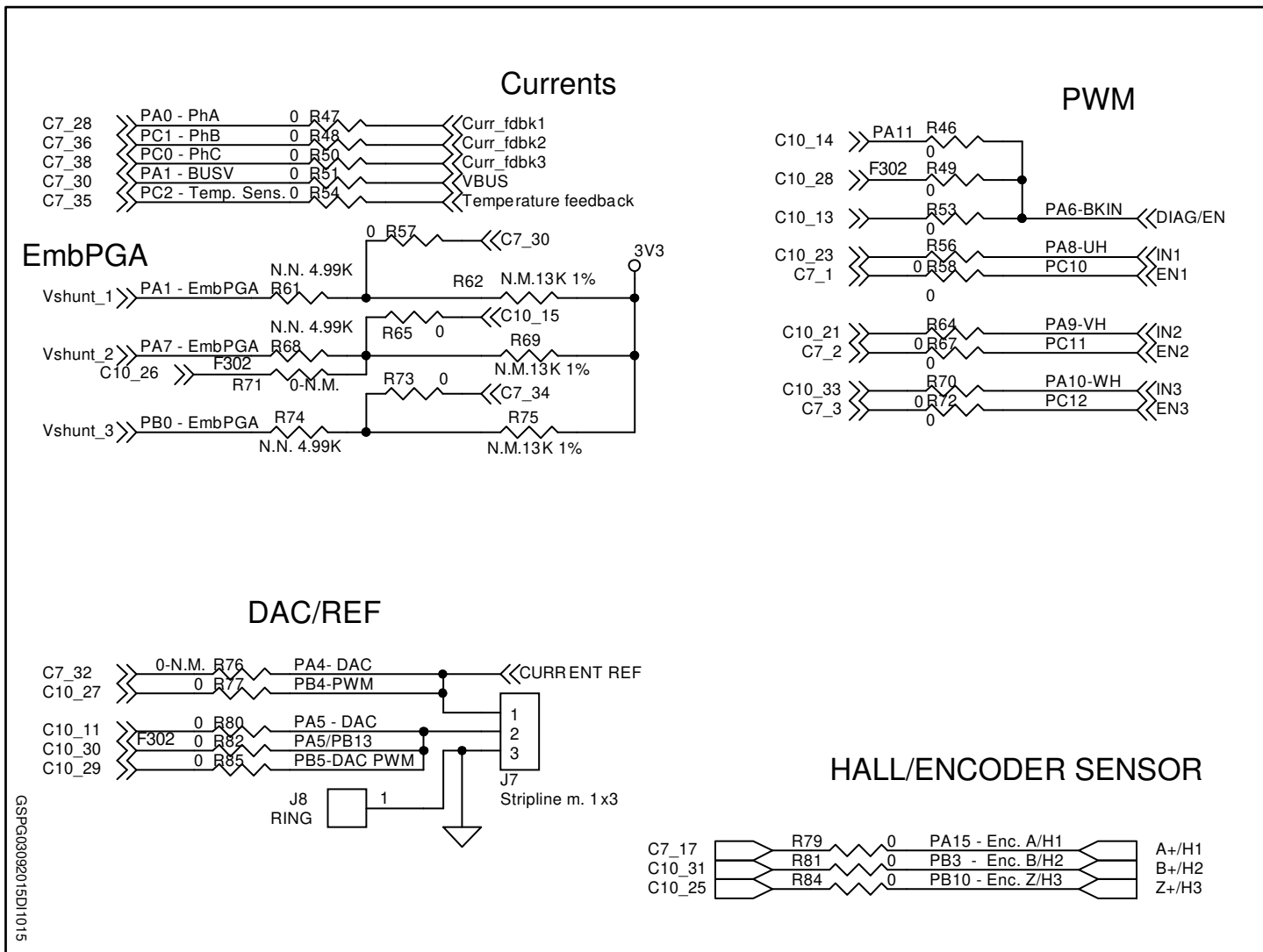

Figure 8: X-NUCLEO-IHM07M1 schematic (4 of 8)

Figure 9: X-NUCLEO-IHM07M1 schematic (5 of 8)



GSPFG03092015D11015

Figure 10: X-NUCLEO-IHM07M1 schematic (6 of 8)

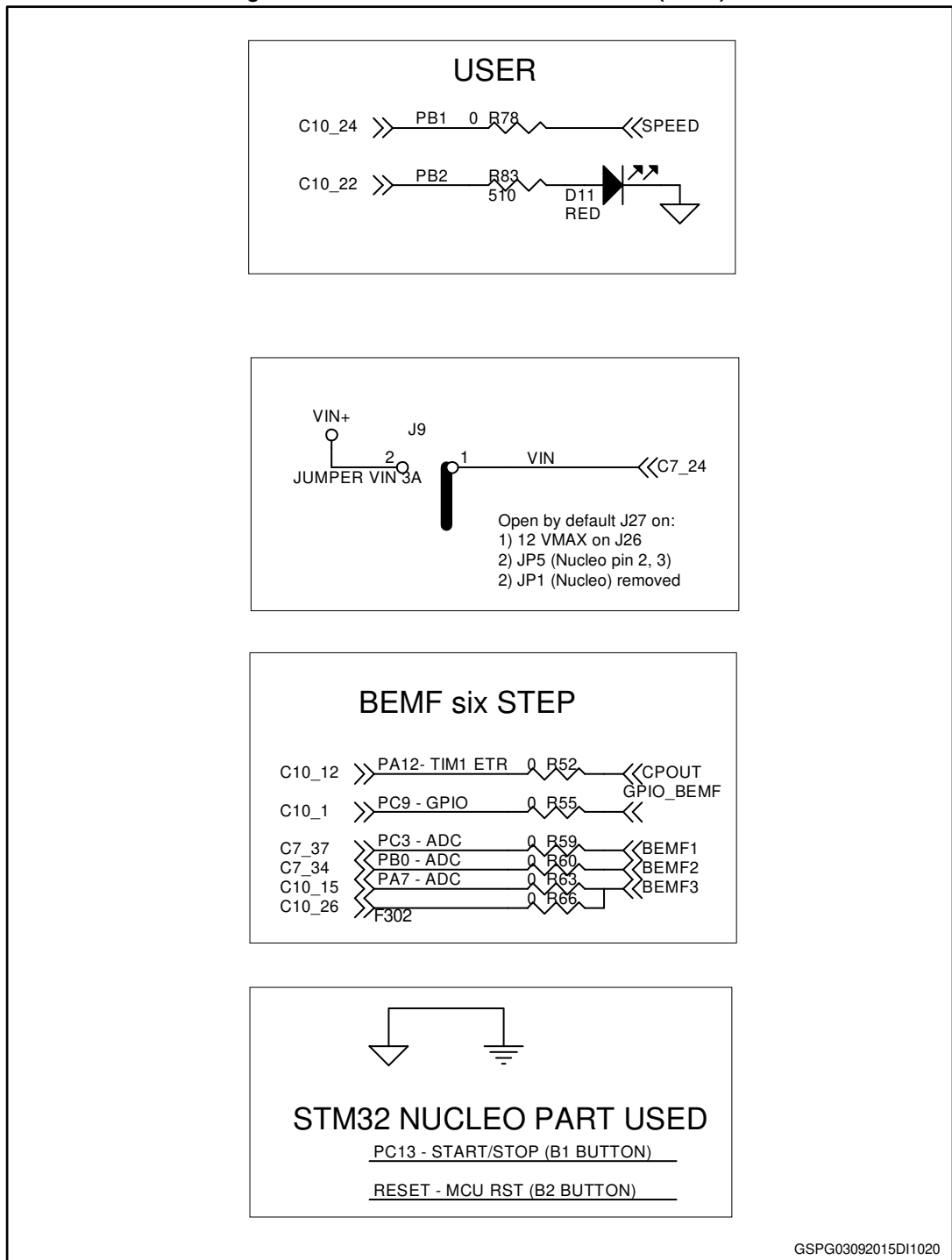
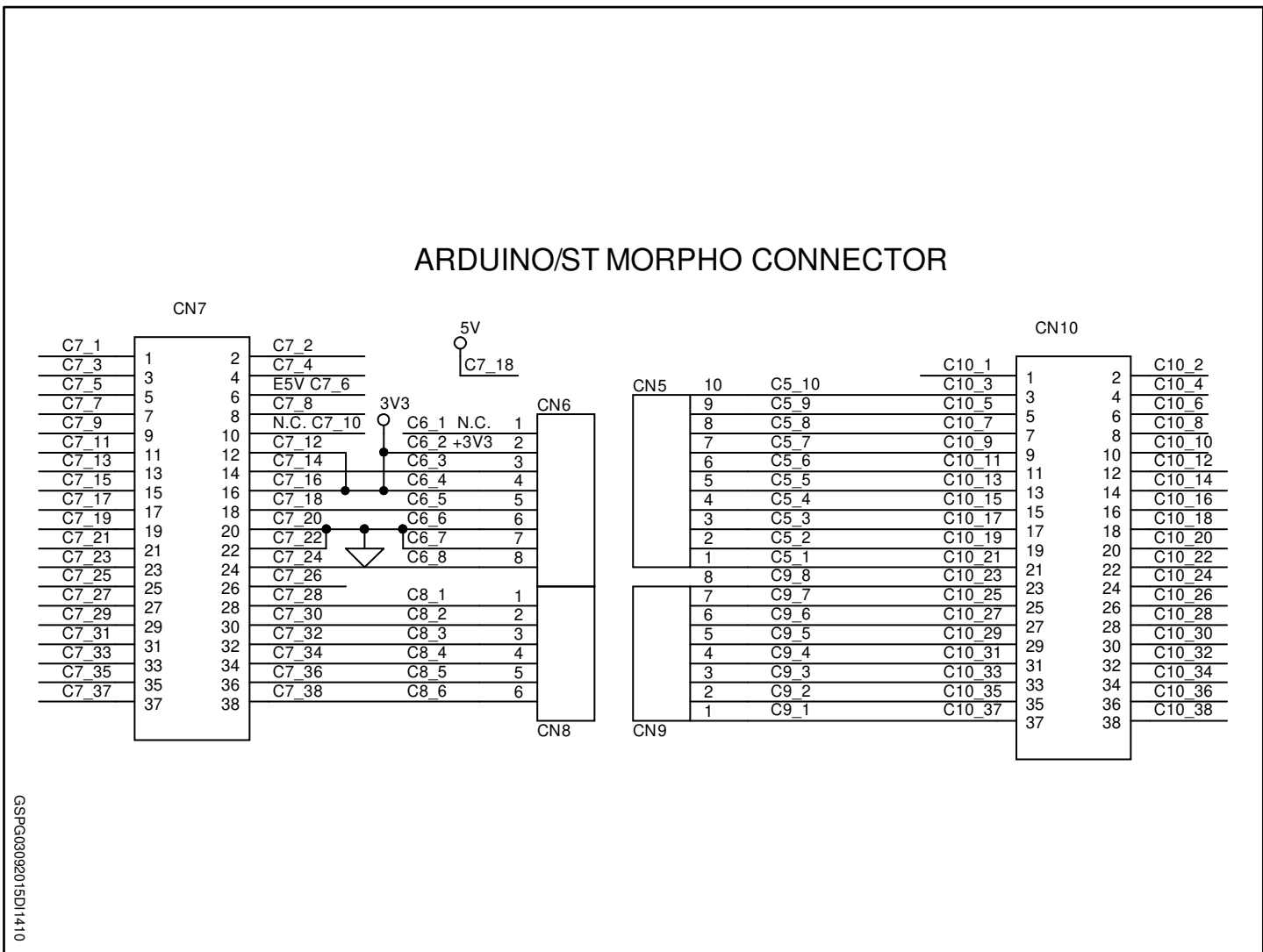

Figure 11: X-NUCLEO-IHM07M1 schematic (7 of 8)



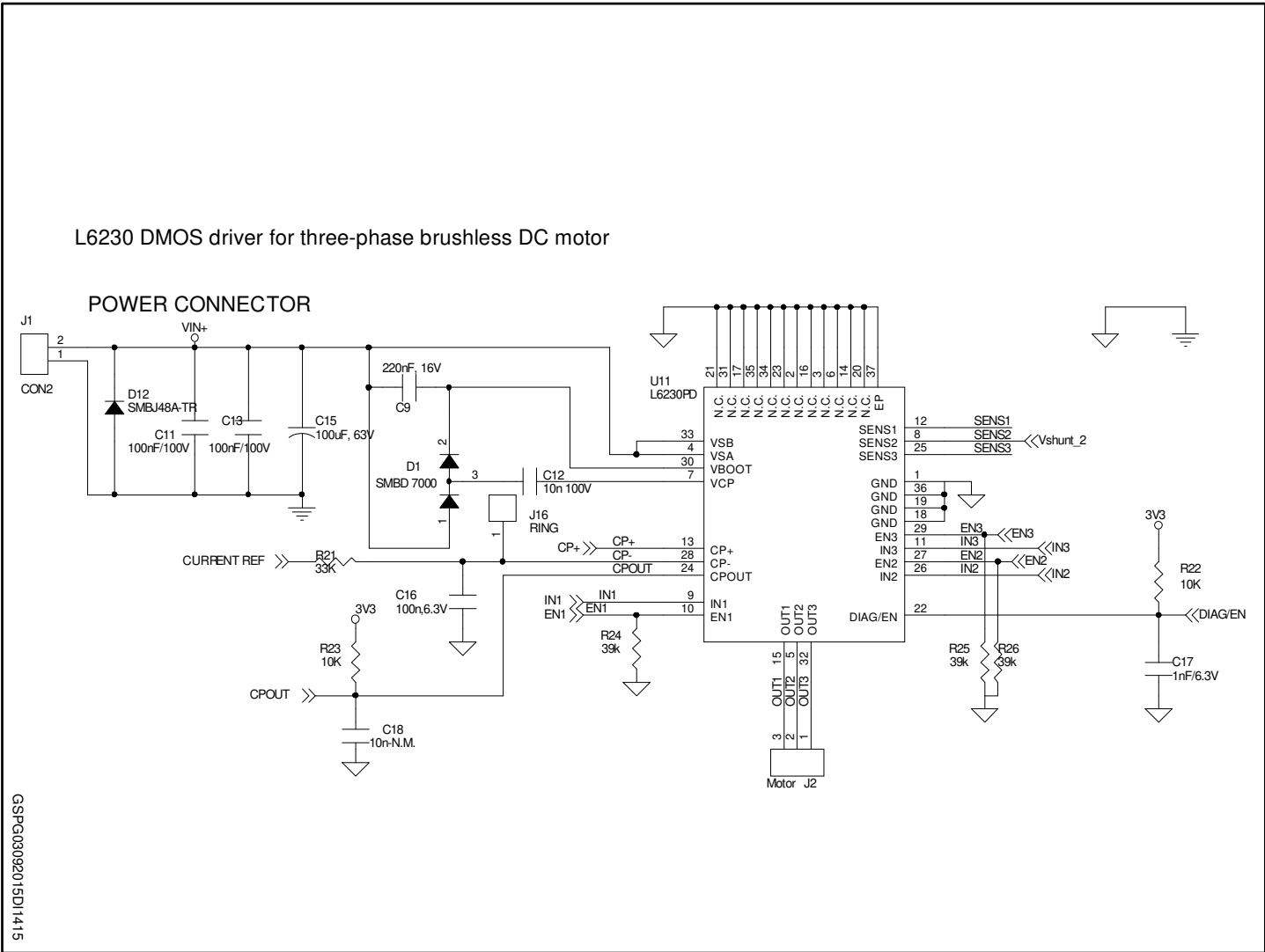

Figure 12: X-NUCLEO-IHM07M1 schematic (8 of 8)

4 Circuit description

4.1 Power section – L6230 driver with integrated three-phase bridge

The main section is based on the L6230. It is a DMOS fully-configurable driver for three-phase brushless BLDC/PMSM motors. The supply voltage is provided through an external connector (J1) and with (J9) jumper settings, it is possible to choose if the digital section (STM32 Nucleo board) must be supplied by USB or by the expansion board. For these settings, please refer to [Table 1: "Jumper settings"](#).

Figure 13: X-NUCLEO-IHM07M1 – power section

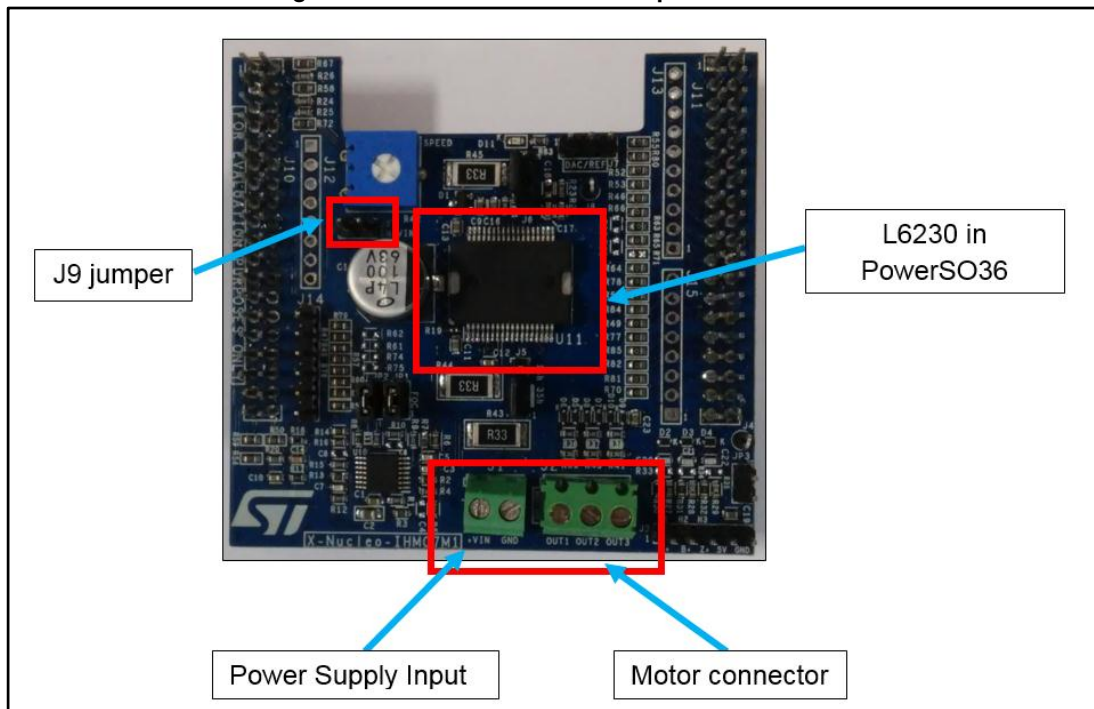

The L6230 integrates a three-phase bridge which consists of six power MOSFETs. Using the N-channel power MOSFET for the upper transistors in the bridge requires a gate drive voltage above the power supply voltage. The bootstrapped supply (VBOOT) is obtained through an internal oscillator and a few external components to implement a charge pump circuit as shown in the diagram that follows.

Figure 14: X-NUCLEO-IHM07M1 – charge pump circuit

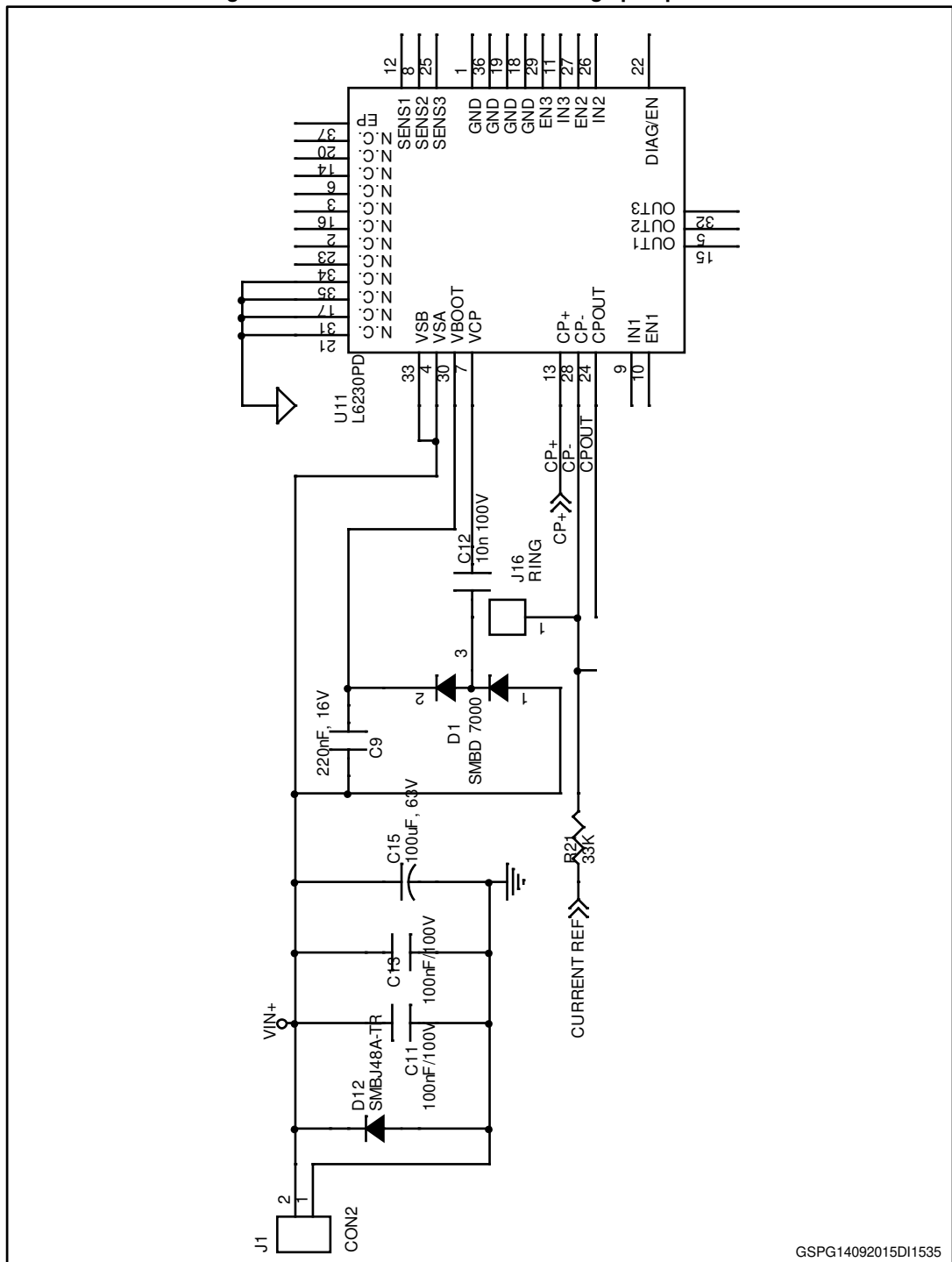

GSPG14092015DI1535

4.2 Power section – Overcurrent detection (OCP) and current sensing measurement

The L6230 driver implements overcurrent protection with an internal detection circuit that does not require an external resistor. The current is compared with an embedded current reference and the output generates a fault condition to the DIAG pin that goes to ground.

This pin, connected to the STM32 Nucleo board (BKIN Timer function), detects this condition and immediately disables the driving signals. The current sensing input is connected to the sensing resistors R_{sense} (refer to the diagram below) and it is possible to choose between three-shunt or single-shunt configuration through the jumpers (J5, J6). For this setting please refer to [Table 1: "Jumper settings"](#).

Figure 15: X-NUCLEO-IHM07M1 – current sensing circuit

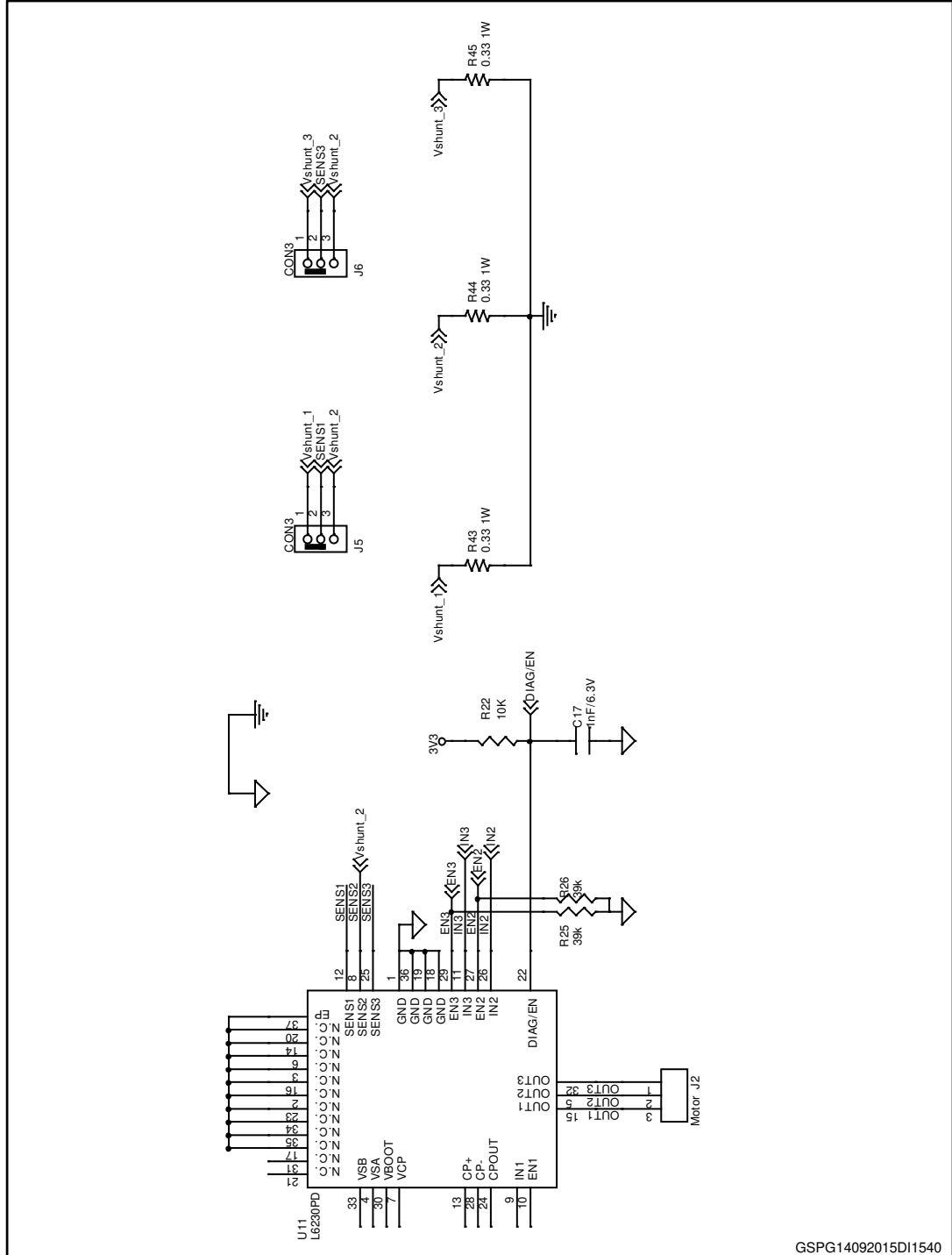

GSPG14092015DI11540

4.3 Analog section – Hall/Encoder motor speed sensor

The X-NUCLEO-IHM07M1 expansion board implements the Hall/Encoder sensor detecting circuit for speed measurement. The motor sensor pin, through the J3 connector and an analog circuit, are connected to the STM32 Nucleo board in order to detect the motor spin; a +5 V and GND are also provided for power supply of the sensors. For sensors that require external pull-up, jumper JP3 is available (see figure below). For this setting please, refer to [Table 1: "Jumper settings"](#).

Figure 16: X-NUCLEO-IHM07M1 – hall/encoder sensor circuit

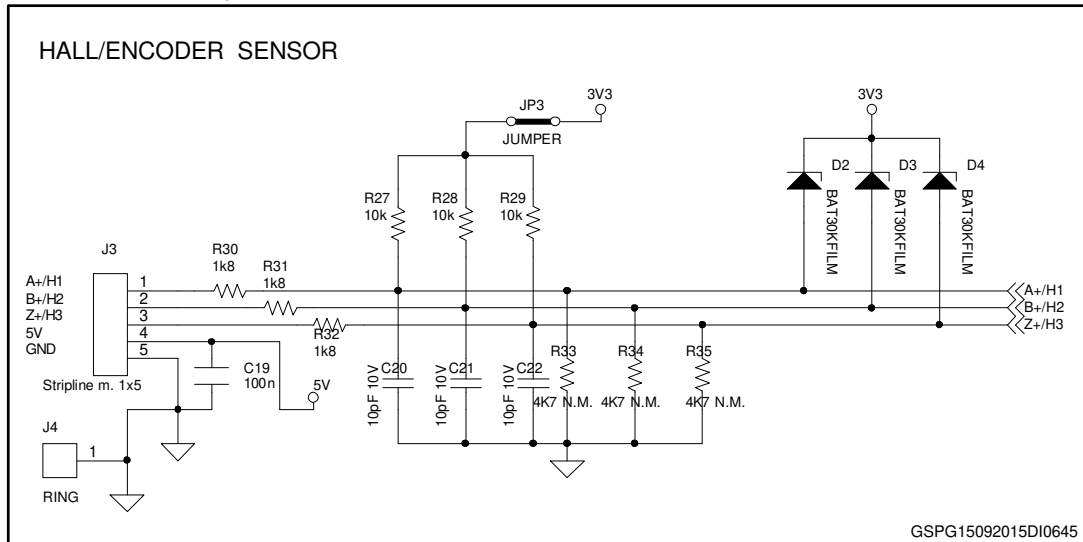

4.4 Analog section – BEMF detection circuit

The X-NUCLEO-IHM07M1 expansion board provides two hardware solutions for motor position measuring, one based on sensors (refer to [Section 4.3: "Analog section – Hall/Encoder motor speed sensor"](#)) and the other based on sensorless detection. In six-step driving mode one of the three phases is left in high impedance state and comparing the voltage of this phase with the center-tap voltage, we can detect the BEMF zero-crossing. This signal is acquired with an analog circuit embedded on the board, as shown in the diagram below.

Figure 17: X-NUCLEO-IHM07M1 – BEMF detection circuit

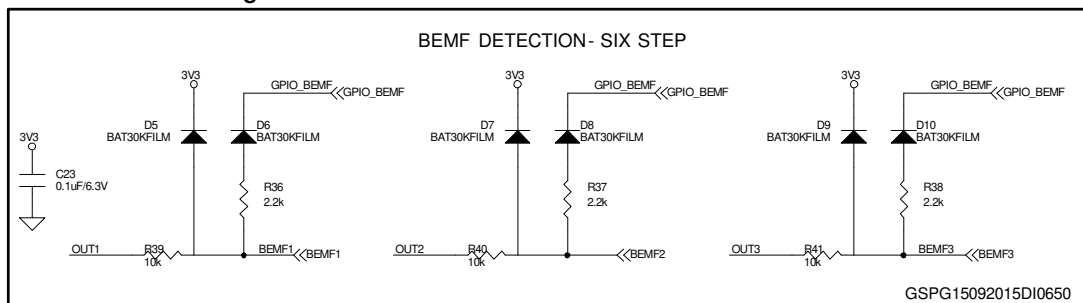

4.5 Analog section – Bus voltage and temperature sensing circuit

The X-NUCLEO-IHM07M1 expansion board provides the hardware for bus voltage sensing and temperature measurement. This signal is acquired respectively with a resistor divider

and with an embedded NTC (placed closed to L6230 driver) as shown in the diagram that follows.

Figure 18: X-NUCLEO-IHM07M1 – VBUS and temperature sensing circuit

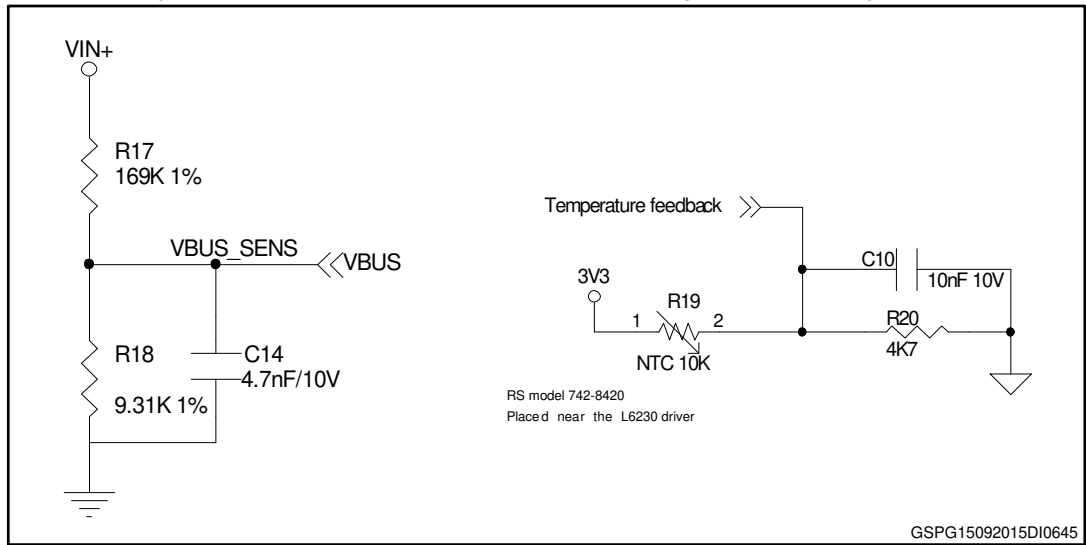

5 BOM (bill of material)

Table 4: BOM (part 1)

Item	Qty	Ref	Part/ value	Volt/Watt/Amp	Type	Tol.
1	4	C1,C16, C19,C23	100nF	10V	Ceramic Multilayer Capacitors X7R	10%
2	1	C2	4.7µF 10V	10V	Ceramic Multilayer Capacitors X7R	20%
3	3	C3,C5,C7	680pF 10V	10V	Ceramic Multilayer Capacitors C0G	5%
4	3	C4,C6,C8	100pF/6.3V	6.3V	Ceramic Multilayer Capacitors X7R	10%
5	1	C9	220nF, 16V	16V	Ceramic Multilayer Capacitors X7R	10%
6	1	C10	10nF 10V	10V	Ceramic Multilayer Capacitors X7R	10%
7	1	C18	10nF 10V	10V	Ceramic Multilayer Capacitors X7R	10%
8	2	C11,C13	100nF	100V	Ceramic Multilayer Capacitors X7R	10%
9	1	C12	10n 100V	100V	Ceramic Multilayer Capacitors X7R	10%
10	1	C14	4.7nF	10V	Ceramic Multilayer Capacitors X7R	10%
11	1	C15	100µF	63V	Aluminium Electrolytic Capacitor	0.2
12	1	C17	1nF	6.3V	Ceramic X7R	10%
13	3	C20,C21,C22	10pF	10V	Ceramic Multilayer Capacitors C0G	5%
14	1	D1	SMBD 7000	200 mA	Signal Diode	
15	9	D2,D3,D4,D5,D6,D7,D8, D9,D10	BAT30KFILM	30V, 0.3A	ST SCHOTTKY DIODE	
16	1	D11	RED		LED standard - SMD	
17	4	JP1,JP2, JP3,J9	JUMPER		2 WAYS STRIP LINE-MALE 2.54mm	
18	1	J1	Input connector		2 way 3.81mm PCB terminal block	
19	1	J2	Motor Connetor		3 way 3.81mm PCB terminal block	
20	1	J3	Stripline m. 1x5		5 WAYS STRIP LINE-MALE 2.54mm	
21	3	J4,J8,J16	RING		TEST POINT 1 mm	
22	3	J5,J6J7	CON3		3 WAYS STRIP LINE-MALE 2.54mm	

BOM (bill of material)

UM1943

Item	Qty	Ref	Part/ value	Volt/Watt/Amp	Type	Tol.
23	2	CN7,CN10	ST_morpho_19x2		ELEVATED SOCKET MORPHO CONNECTOR 38 PIN (19x2)	
24	2	CN6,CN9	CONN8		8 PIN ELEVATED SOCKET	
25	1	CN5	CONN10		10 PIN ELEVATED SOCKET	
26	1	CN8	CONN6		6 PIN ELEVATED SOCKET	
27	13	R1,R4,R5,R6,R9,R10, R11,R12,R15,R16,R36, R37,R38	2.2 kOhm	0.1W	SMD RESISTOR	1%
28	3	R2,R7,R13	680 Ohm	0.1W	SMD RESISTOR	
29	34	R3,R8,R14,R46,R47,R48 ,R49,R50,R51,R52,R53, R54,R55,R56,R57,R58, R59,R60,R63,R64,R65, R66,R67,R70,R72,R73, R77,R78,R79,R80,R81, R82,R84,R85	0 Ohm	0.1W	SMD RESISTOR	
30	1	R17	169 kOhm	0.1W	SMD RESISTOR	1%
31	1	R18	9.31 kOhm	0.1W	SMD RESISTOR	1%
32	1	R19	NTC 10kOhm		NTC Thermistor	1%
33	1	R20	4.7 kOhm	0.1W	SMD RESISTOR	
34	1	R21	33 kOhm	0.1W	SMD RESISTOR	
35	5	R22,R23,R27,R28,R29	10 kOhm	0.1W	SMD RESISTOR	
36	3	R39,R40,R41	10 kOhm	0.25W	SMD RESISTOR	
37	3	R24,R25,R26	39 kOhm	0.1W	SMD RESISTOR	
38	3	R30,R31,R32	1.8 kOhm	0.1W	SMD RESISTOR	
39	3	R33,R34,R35	4.7 kOhm	0.1W	SMD RESISTOR	
40	1	R42	100 kOhm	1/2W	TRIMMER RESISTOR	10%
41	3	R43,R44,R45	0.33 Ohm	1W	SHUNT RESISTOR	1%
42	3	R61,R68,R74	4.99 kOhm	0.1W	SMD RESISTOR	
43	3	R62,R69,R75	13 kOhm	0.1W	SMD RESISTOR	
44	2	R71,R76	0 N.M.	0.1W	SMD RESISTOR	
45	1	R83	510 Ohm	0.1W	SMD RESISTOR	
46	1	U10	TSV994IPT		Operational Amplifier	
47	1	U11	L6230PD		DMOS driver for three-phase brushless DC motor	
48	6	(*) Jumper			Female 2.54mm jumper	



Item	Qty	Ref	Part/ value	Volt/Watt/Amp	Type	Tol.
49	1	X	SMBJ48A-TR		Transil™	

Table 5: BOM (part 2)

Item	Package	Manufacturer	Orderable part number
1	0603	ANY	ANY
2	0805	TDK	C2012X7R1A475M125AC
3	0603	ANY	ANY
4	0603	ANY	ANY
5	0603	ANY	ANY
6	0603	ANY	ANY
7	0603	ANY	ANY
8	0603	ANY	ANY
9	0603	ANY	ANY
10	0603	ANY	ANY
11	SMD 10 mm x 10.5 mm	Nichicon	UUX1J101MNL1GS
12	0603	ANY	
13	0603	ANY	ANY
14	SOT-23	Infineon	SMBD 7000
15	SOD-523	STMicroelectronics	BAT30KFILM
16	SMD 0603	Lite-on	LTST-C193KRKT-5A
17	TH 2.54 mm pitch	any	
18	TH 3.81 pitch	any	
19	TH 3.81 pitch	any	
20	TH 2.54 mm pitch	any	
21	TH	Vero Technologies	20-2137
22	TH 2.54 mm pitch	any	
23	TH 2.54 mm pitch	Samtec	ESQ-119-24-T-D
24	TH 2.54 mm pitch	Samtec	ESQ-108-24-T-S
25	TH 2.54 mm pitch	Samtec	ESQ-110-24-T-S
26	TH 2.54 mm pitch	Samtec	ESQ-106-24-T-S
27	0603	ANY	ANY
28	0603	ANY	ANY
29	0603	ANY	ANY
30	0603	Vishay	CRCW0603169KFKEA
31	0603	PANASONIC	ERJ3EKF9311V
32		TDK	NTCG103JF103F