



Chipsmall Limited consists of a professional team with an average of over 10 year of expertise in the distribution of electronic components. Based in Hongkong, we have already established firm and mutual-benefit business relationships with customers from,Europe,America and south Asia,supplying obsolete and hard-to-find components to meet their specific needs.

With the principle of “Quality Parts,Customers Priority,Honest Operation,and Considerate Service”,our business mainly focus on the distribution of electronic components. Line cards we deal with include Microchip,ALPS,ROHM,Xilinx,Pulse,ON,Everlight and Freescale. Main products comprise IC,Modules,Potentiometer,IC Socket,Relay,Connector.Our parts cover such applications as commercial,industrial, and automotives areas.

We are looking forward to setting up business relationship with you and hope to provide you with the best service and solution. Let us make a better world for our industry!



Contact us

Tel: +86-755-8981 8866 Fax: +86-755-8427 6832

Email & Skype: info@chipsmall.com Web: www.chipsmall.com

Address: A1208, Overseas Decoration Building, #122 Zhenhua RD., Futian, Shenzhen, China



24 V Intelligent power switch expansion board based on VPS2535H for STM32 Nucleo

Data brief - production data

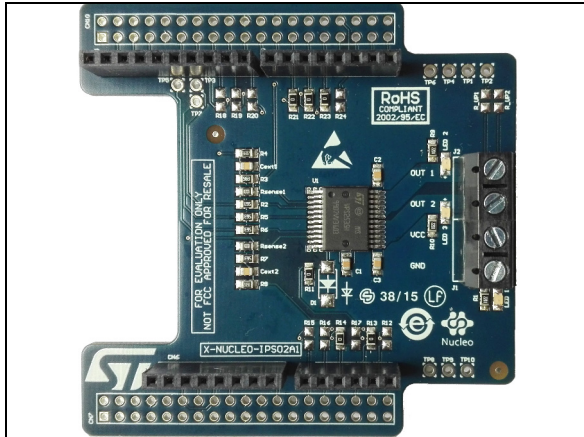

single STM32 Nucleo board. The user can also mount the ST morpho connector.

The X-NUCLEO-IPS02A1 expansion board is based on the VPS2535H a double channel High Side Driver through a 3 V and 5 V CMOS-compatible interface and with multisense analog feedback and protections

The device VPS2535H integrates advanced protective functions such as the load current limitation protects the device in overload conditions. The device latches off in case of overload or thermal shutdown.

Table 1. Device summary

Order code	Reference
X-NUCLEO-IPS02A1	X-NUCLEO-IPS02A1 with VPS2535H

Features

- Operating Voltage range from 8 V to 36 V
- Current limitation: 42 A
- RON (per Ch): 35 mΩ @ 25 C
- Stand-By Current: 2 μA
- Temperature range: -40°C ÷ 150°C
- Power ok and Output LEDs
- Multisense Analog feedback
- Fully protected device
- Compatible with Arduino™ UNO R3 connector
- Compatible with STM32 Nucleo boards
- RoHS compliant

Description

The X-NUCLEO-IPS02A1 provides an affordable and easy-to-use solution for driving grounded loads (i.e. heating elements, solenoid driver, LED driver, light bulb driver, pumps relay replacement, and fans) in STM32 Nucleo projects.

This expansion board is compatible with the Arduino UNO R3 connector and supports the addition of other STM32 expansion boards with a

1 Schematic diagram

Figure 1. Connectors

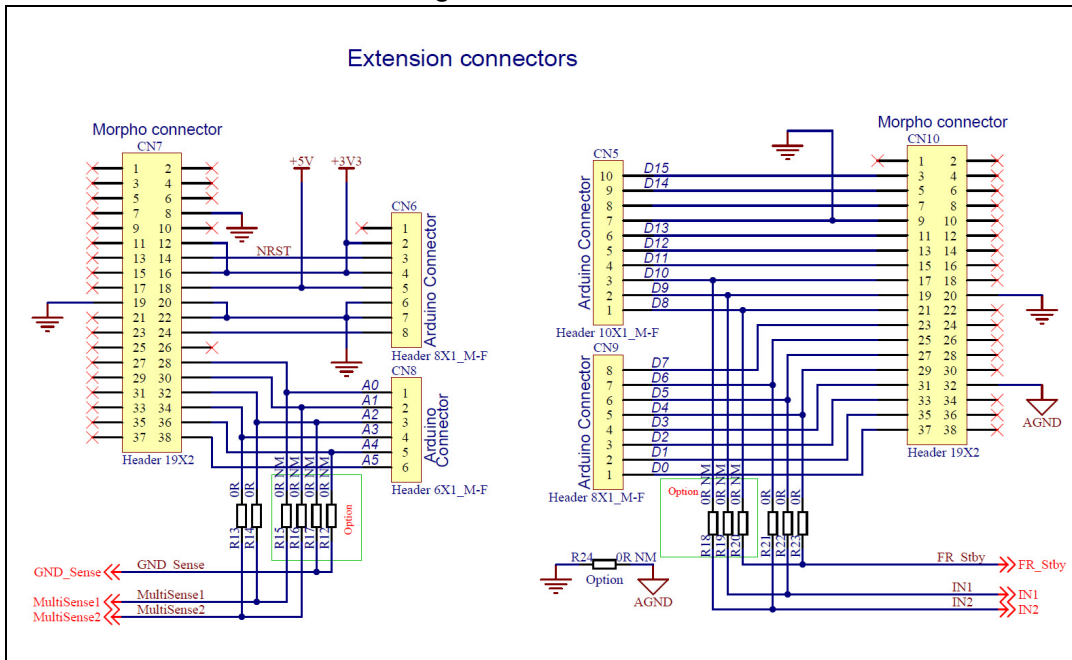
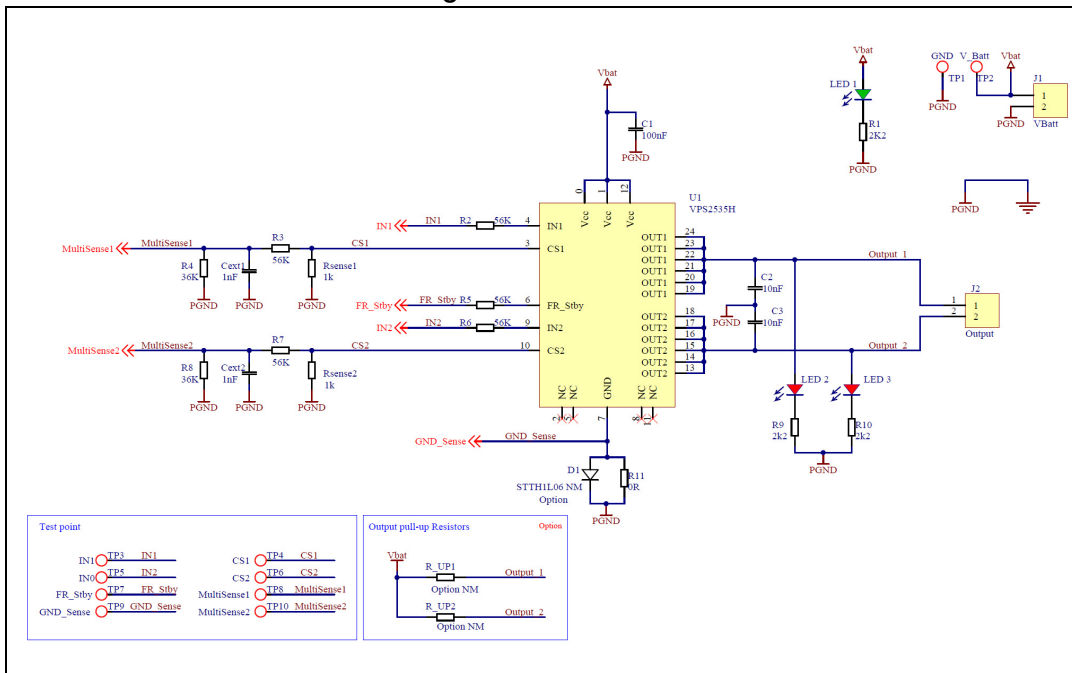

Figure 2. VPS2535H



2 Revision history

Table 2. Document revision history

Date	Revision	Changes
18-May-2016	1	Initial release.

IMPORTANT NOTICE – PLEASE READ CAREFULLY

STMicroelectronics NV and its subsidiaries ("ST") reserve the right to make changes, corrections, enhancements, modifications, and improvements to ST products and/or to this document at any time without notice. Purchasers should obtain the latest relevant information on ST products before placing orders. ST products are sold pursuant to ST's terms and conditions of sale in place at the time of order acknowledgement.

Purchasers are solely responsible for the choice, selection, and use of ST products and ST assumes no liability for application assistance or the design of Purchasers' products.

No license, express or implied, to any intellectual property right is granted by ST herein.

Resale of ST products with provisions different from the information set forth herein shall void any warranty granted by ST for such product.

ST and the ST logo are trademarks of ST. All other product or service names are the property of their respective owners.

Information in this document supersedes and replaces information previously supplied in any prior versions of this document.

© 2016 STMicroelectronics – All rights reserved