



Chipsmall Limited consists of a professional team with an average of over 10 year of expertise in the distribution of electronic components. Based in Hongkong, we have already established firm and mutual-benefit business relationships with customers from,Europe,America and south Asia,supplying obsolete and hard-to-find components to meet their specific needs.

With the principle of “Quality Parts,Customers Priority,Honest Operation,and Considerate Service”,our business mainly focus on the distribution of electronic components. Line cards we deal with include Microchip,ALPS,ROHM,Xilinx,Pulse,ON,Everlight and Freescale. Main products comprise IC,Modules,Potentiometer,IC Socket,Relay,Connector.Our parts cover such applications as commercial,industrial, and automotives areas.

We are looking forward to setting up business relationship with you and hope to provide you with the best service and solution. Let us make a better world for our industry!



Contact us

Tel: +86-755-8981 8866 Fax: +86-755-8427 6832

Email & Skype: info@chipsmall.com Web: www.chipsmall.com

Address: A1208, Overseas Decoration Building, #122 Zhenhua RD., Futian, Shenzhen, China



NFC card reader expansion board based on CR95HF for STM32 Nucleo

Data brief

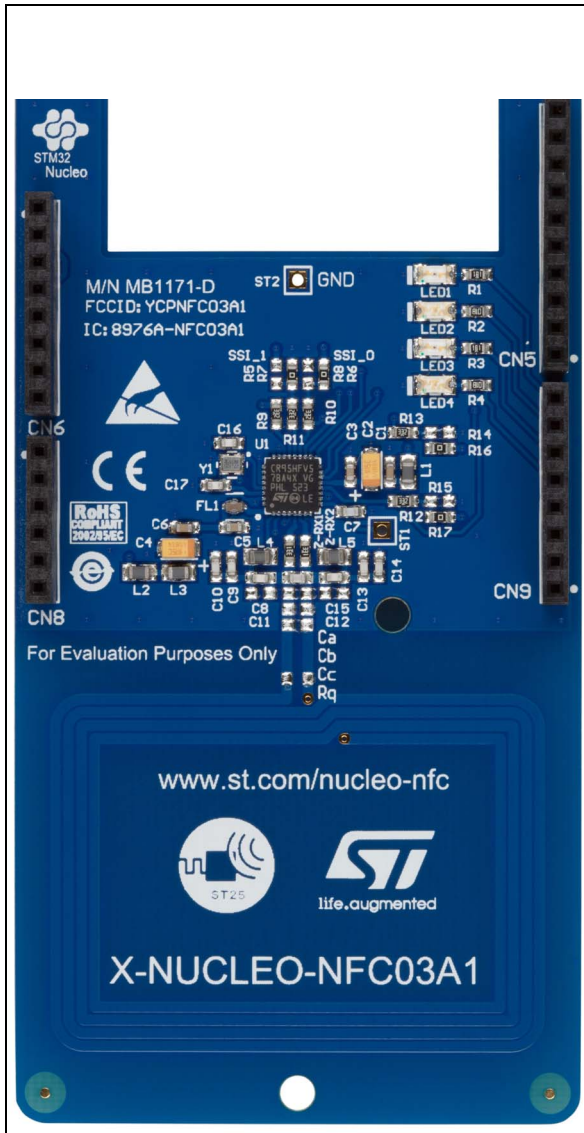

Features

- NFC (Near Field Communication) card reader evaluation board based on CR95HF, designed for expansion of STM32 Nucleo boards
- Reader/Writer modes supported
- 47 mm x 34 mm, four turns, 13.56 MHz inductive antenna etched on PCB, and associated tuning circuit
- RF communication
 - ISO/IEC 14443 (A and B)
 - ISO/IEC 15693
 - ISO/IEC 18092
 - MIFARE® Classic compatible
- Equipped with Arduino™ UNO R3 connector
- Four general purpose LEDs
- Scalable solution, capable of cascading multiple boards for larger systems
- Free comprehensive development firmware library and examples for CR95HF, compatible with STM32Cube firmware
- FCC certified
- RoHS compliant

1 Description

The X-NUCLEO-NFC03A1 (see [Figure 1](#)) is an NFC card reader evaluation board based on CR95HF-VMD5T to enable expansion of the STM32 Nucleo boards.

The CR95HF manages frame coding and decoding in Reader mode for standard applications, such as NFC, proximity and vicinity standards.

The CR95HF embeds an analog front end to provide the 13.56 MHz air interface.

The CR95HF supports ISO/IEC 14443 Type A and B, ISO/IEC 15693 (single or double subcarrier) and ISO/IEC 18092 communication protocols, besides being MIFARE® Classic compatible^(a). It also supports the detection, reading and writing of NFC Forum Type 1, 2, 3 and 4 tags.

The CR95HF features an optimized power management scheme, including tag detection mode.

Communication with the Host Controller is ensured through Serial Peripheral Interface (SPI) Slave or Universal Asynchronous Receiver/Transmitter (UART).

The X-NUCLEO-NFC03A1 is compatible with the ST Arduino™ UNO R3 connector pin assignment.

Figure 1. Functional block diagram

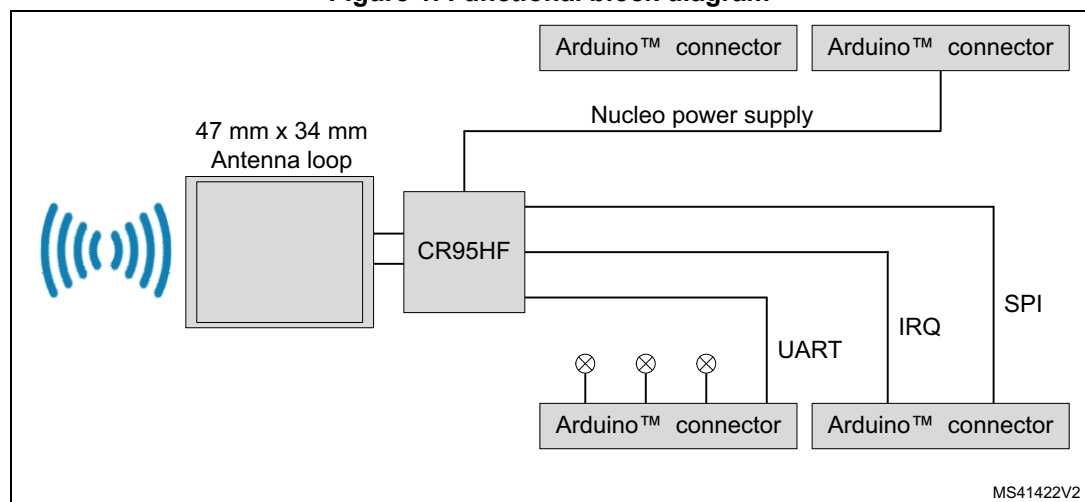

a. MIFARE and MIFARE Classic are registered trademarks of NXP B.V. and are used under license.

2 Schematics

Figure 2. Nucleo connectors

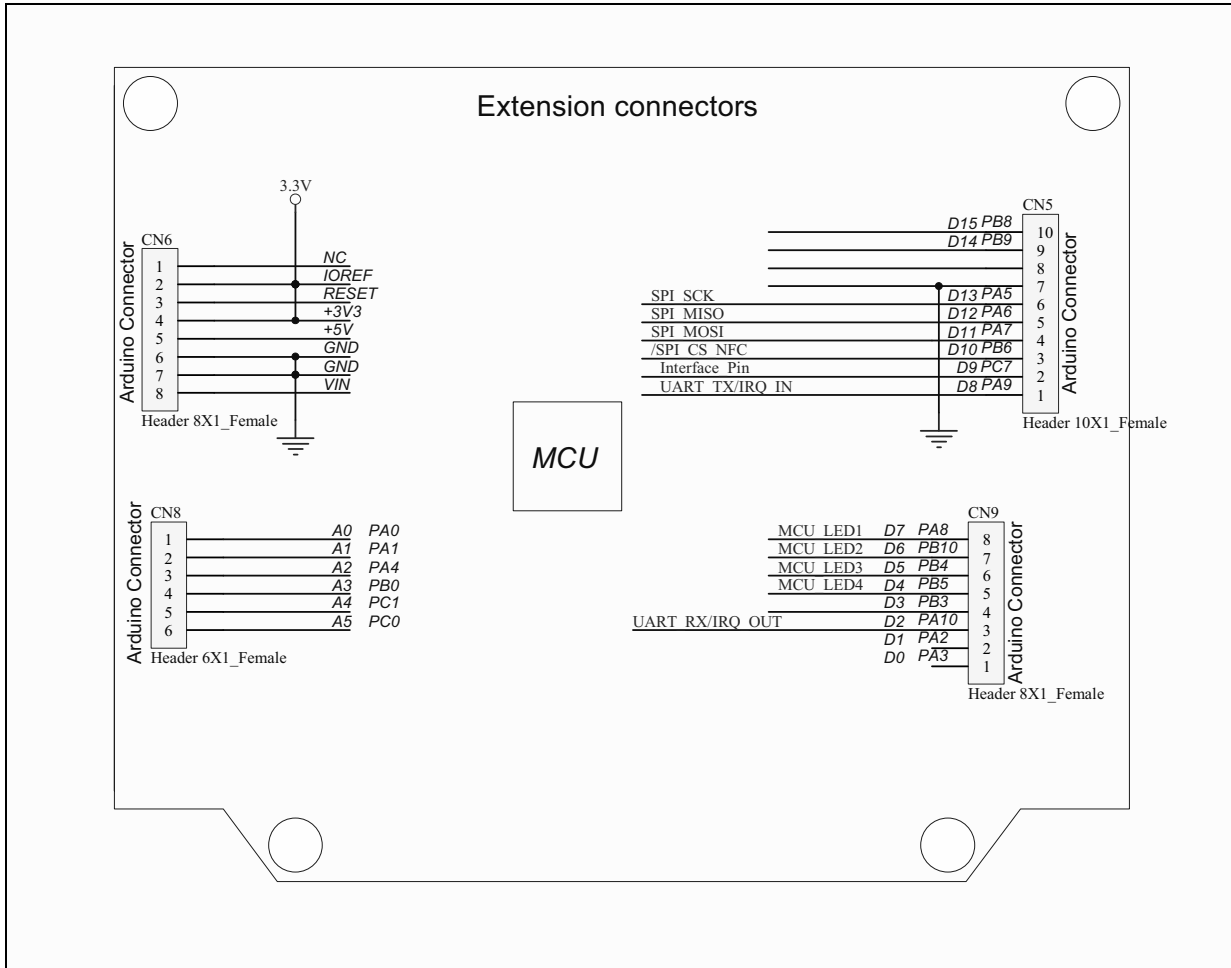

Figure 3. General purpose LEDs

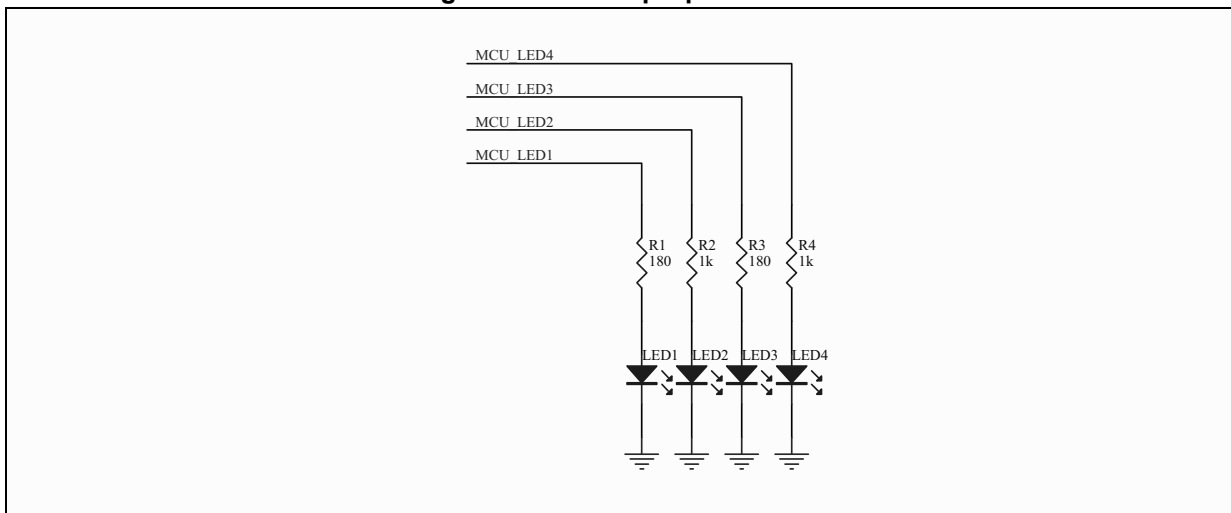
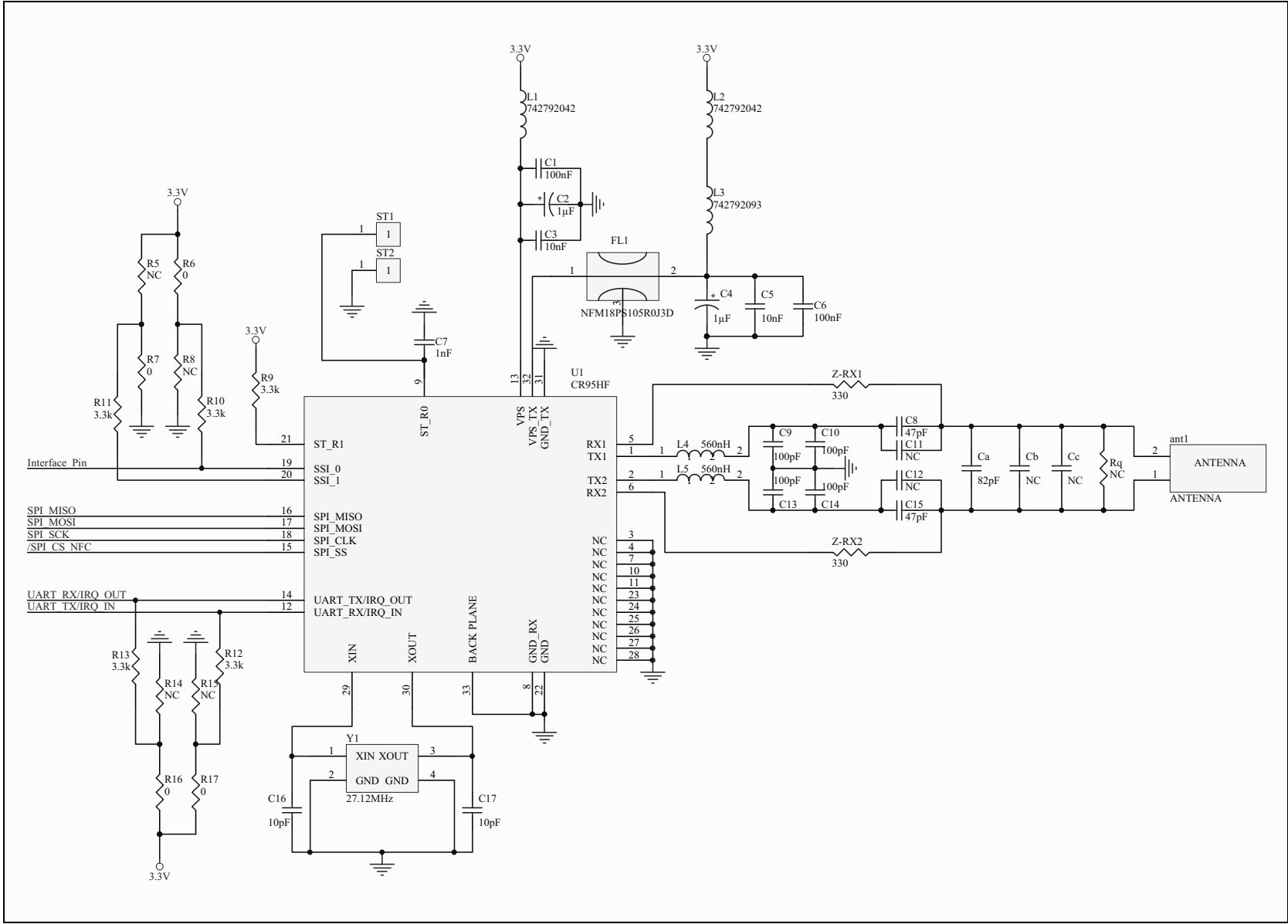



Figure 4. CR95HF and matching circuitry



3 Federal Communications Commission (FCC) and Industry Canada (IC) compliance statements

3.1 FCC Compliance Statement

3.1.1 Part 15.19

This device complies with Part 15 of the FCC Rules. Operation is subject to the following two conditions: (1) this device may not cause harmful interference, and (2) this device must accept any interference received, including interference that may cause undesired operation.

3.1.2 Part 15.21

Any changes or modifications to this equipment not expressly approved by STMicroelectronics may cause harmful interference and void the user's authority to operate this equipment.

3.1.3 FCC ID

FCC ID: YCPNFC03A1

3.2 Formal notices required by the Industry Canada ("IC")

3.2.1 Compliance Statement

This device complies with Industry Canada licence-exempt RSS standard(s). Operation is subject to the following two conditions: (1) this device may not cause interference, and (2) this device must accept any interference, including interference that may cause undesired operation.

3.2.2 Declaration de Conformité

Le présent appareil est conforme aux CNR d'Industrie Canada applicables aux appareils radio exempts de licence. L'exploitation est autorisée aux deux conditions suivantes: (1) l'appareil ne doit pas produire de brouillage, et (2) l'utilisateur de l'appareil doit accepter tout brouillage radioélectrique subi, même si le brouillage est susceptible d'en compromettre le fonctionnement.

3.2.3 IC ID

IC ID: 8976A-NFC03A1

4 Revision history

Table 1. Document revision history

Date	Revision	Changes
21-Jul-2014	1	Initial release.
03-Sept-2014	2	Changed classification to confidential.
03-May-2016	3	Changed document classification. Updated title and image on cover page. Updated <i>Features</i> and <i>Section 1: Description</i> . Updated <i>Figure 1: Functional block diagram</i> . Added <i>Section 2: Schematics</i> and <i>Section 3: Federal Communications Commission (FCC) and Industry Canada (IC) compliance statements</i> .
16-Jun-2016	4	Updated image on cover page. Updated <i>Figure 1: Functional block diagram</i> . Updated <i>Section 3.2.3: IC ID</i> .

IMPORTANT NOTICE – PLEASE READ CAREFULLY

STMicroelectronics NV and its subsidiaries (“ST”) reserve the right to make changes, corrections, enhancements, modifications, and improvements to ST products and/or to this document at any time without notice. Purchasers should obtain the latest relevant information on ST products before placing orders. ST products are sold pursuant to ST’s terms and conditions of sale in place at the time of order acknowledgement.

Purchasers are solely responsible for the choice, selection, and use of ST products and ST assumes no liability for application assistance or the design of Purchasers’ products.

No license, express or implied, to any intellectual property right is granted by ST herein.

Resale of ST products with provisions different from the information set forth herein shall void any warranty granted by ST for such product.

ST and the ST logo are trademarks of ST. All other product or service names are the property of their respective owners.

Information in this document supersedes and replaces information previously supplied in any prior versions of this document.

© 2016 STMicroelectronics – All rights reserved