



Chipsmall Limited consists of a professional team with an average of over 10 year of expertise in the distribution of electronic components. Based in Hongkong, we have already established firm and mutual-benefit business relationships with customers from,Europe,America and south Asia,supplying obsolete and hard-to-find components to meet their specific needs.

With the principle of “Quality Parts,Customers Priority,Honest Operation,and Considerate Service”,our business mainly focus on the distribution of electronic components. Line cards we deal with include Microchip,ALPS,ROHM,Xilinx,Pulse,ON,Everlight and Freescale. Main products comprise IC,Modules,Potentiometer,IC Socket,Relay,Connector.Our parts cover such applications as commercial,industrial, and automotives areas.

We are looking forward to setting up business relationship with you and hope to provide you with the best service and solution. Let us make a better world for our industry!



Contact us

Tel: +86-755-8981 8866 Fax: +86-755-8427 6832

Email & Skype: info@chipsmall.com Web: www.chipsmall.com

Address: A1208, Overseas Decoration Building, #122 Zhenhua RD., Futian, Shenzhen, China



Dual Digitally-Controlled (XDCP™) Potentiometers

FEATURES

- **Dual—Two Separate Potentiometers**
- **256 Resistor Taps/Pot—0.4% Resolution**
- **2-Wire Serial Interface for Write, Read, and Transfer Operations of the Potentiometer**
- **Wiper Resistance, 100Ω typical @ V+ = 5V, V- = -5V**
- **16 Nonvolatile Data Registers for Each Potentiometer**
- **Nonvolatile Storage of Multiple Wiper Positions**
- **Power-on Recall. Loads Saved Wiper Position on Power-up.**
- **Standby Current <5μA Max**
- **V_{CC}: ±2.7V to ±5.5V Operation**
- **50kΩ, 100kΩ Versions of End to End Pot Resistance**
- **Endurance: 100,000 Data Changes per Bit per Register**
- **100 yr. Data Retention**
- **24 Ld SOIC**
- **Low Power CMOS**
- **Power Supply V_{CC} = ±2.7V to ±5.5V
V+ = 2.7V to 5.5V
V- = -2.7V to -5.5V**
- **Pb-Free Plus Anneal Available (RoHS Compliant)**

DESCRIPTION

The X9268 integrates 2 digitally controlled potentiometer (XDCP) on a monolithic CMOS integrated circuit.

The digital controlled potentiometer is implemented using 255 resistive elements in a series array. Between each element are tap points connected to the wiper terminal through switches. The position of the wiper on the array is controlled by the user through the 2-Wire bus interface. Each potentiometer has associated with it a volatile Wiper Counter Register (WCR) and a four nonvolatile Data Registers that can be directly written to and read by the user. The contents of the WCR controls the position of the wiper on the resistor array through the switches. Powerup recalls the contents of the default Data Register (DR0) to the WCR.

The XDCP can be used as a three-terminal potentiometer or as a two terminal variable resistor in a wide variety of applications including control, parameter adjustments, and signal processing.

FUNCTIONAL DIAGRAM

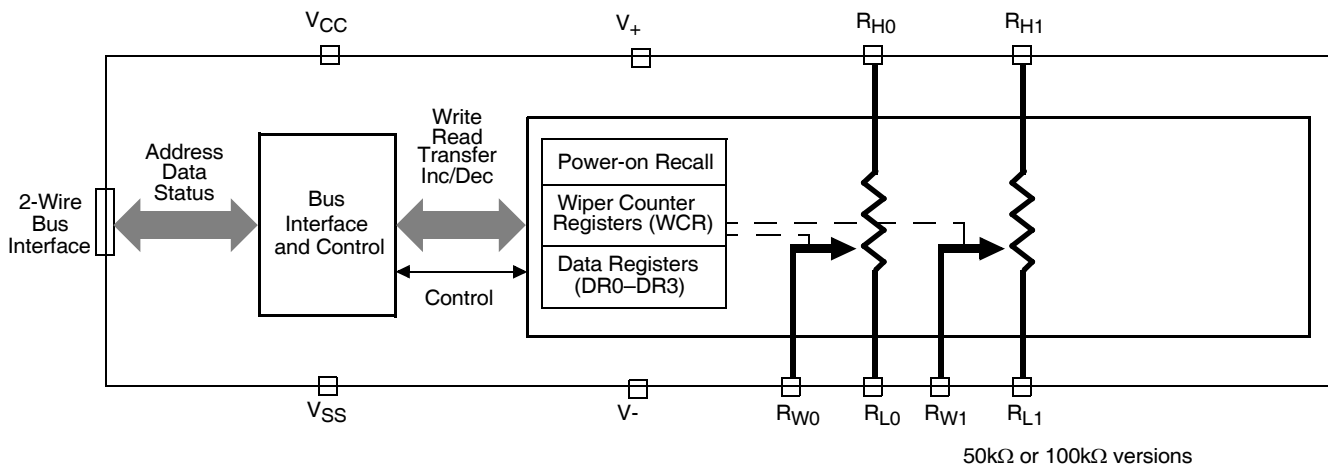

Ordering Information

PART NUMBER	PART MARKING	V _{CC} LIMITS (V)	POTENTIOMETER ORGANIZATION (kΩ)	TEMP. RANGE (°C)	PACKAGE	PKG. DWG. #	
X9268TS24	X9268TS	5 ±10%	100	0 to +70	24 Ld SOIC (300mil)	M24.3	
X9268TS24Z (Note)	X9268TS Z			0 to +70	24 Ld SOIC (300mil) (Pb-free)	M24.3	
X9268TS24I	X9268TS I			-40 to +85	24 Ld SOIC (300mil)	M24.3	
X9268TS24IZ (Note)	X9268TS ZI			-40 to +85	24 Ld SOIC (300mil) (Pb-free)	M24.3	
X9268US24	X9268US		5 ±10%	50	0 to +70	24 Ld SOIC (300mil)	M24.3
X9268US24Z (Note)	X9268US Z				0 to +70	24 Ld SOIC (300mil) (Pb-free)	M24.3
X9268US24I	X9268US I				-40 to +85	24 Ld SOIC (300mil)	M24.3
X9268US24IZ (Note)	X9268US ZI				-40 to +85	24 Ld SOIC (300mil) (Pb-free)	M24.3
X9268TS24I-2.7	X9268TS G	2.7 to 5.5		100	-40 to +85	24 Ld SOIC (300mil)	M24.3
X9268TS24IZ-2.7 (Note)	X9268TS ZG				-40 to +85	24 Ld SOIC (300mil) (Pb-Free)	M24.3

*Add "T1" suffix for tape and reel.

NOTE: Intersil Pb-free plus anneal products employ special Pb-free material sets; molding compounds/die attach materials and 100% matte tin plate termination finish, which are RoHS compliant and compatible with both SnPb and Pb-free soldering operations. Intersil Pb-free products are MSL classified at Pb-free peak reflow temperatures that meet or exceed the Pb-free requirements of IPC/JEDEC J STD-020.

DETAILED FUNCTIONAL DIAGRAM

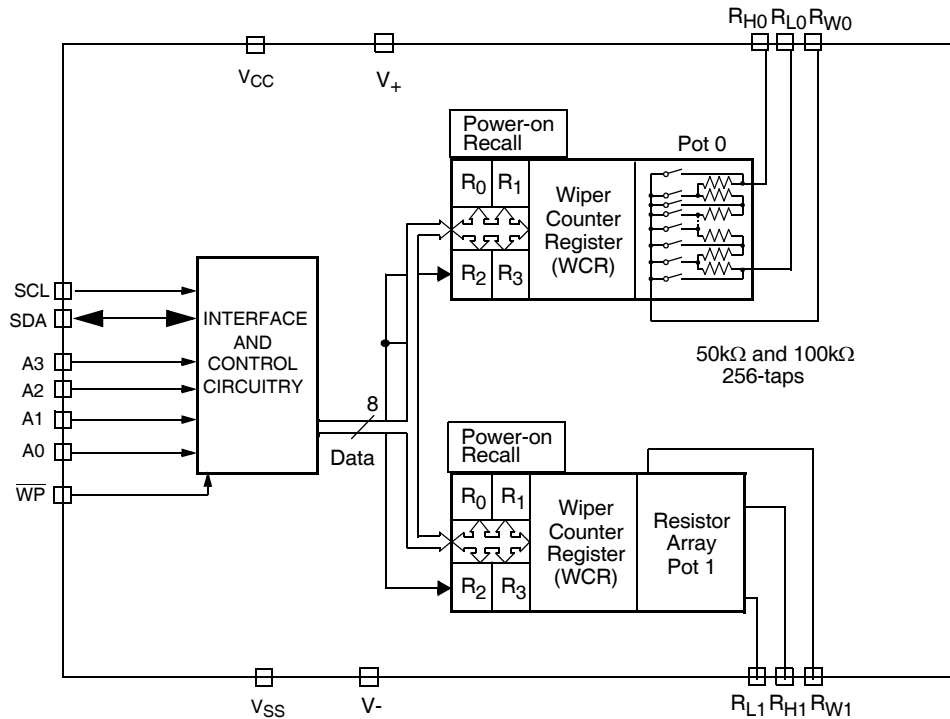

CIRCUIT LEVEL APPLICATIONS

- Vary the gain of a voltage amplifier
- Provide programmable dc reference voltages for comparators and detectors
- Control the volume in audio circuits
- Trim out the offset voltage error in a voltage amplifier circuit
- Set the output voltage of a voltage regulator
- Trim the resistance in Wheatstone bridge circuits
- Control the gain, characteristic frequency and Q-factor in filter circuits
- Set the scale factor and zero point in sensor signal conditioning circuits
- Vary the frequency and duty cycle of timer ICs
- Vary the dc biasing of a pin diode attenuator in RF circuits
- Provide a control variable (I, V, or R) in feedback circuits

SYSTEM LEVEL APPLICATIONS

- Adjust the contrast in LCD displays
- Control the power level of LED transmitters in communication systems
- Set and regulate the DC biasing point in an RF power amplifier in wireless systems
- Control the gain in audio and home entertainment systems
- Provide the variable DC bias for tuners in RF wireless systems
- Set the operating points in temperature control systems
- Control the operating point for sensors in industrial systems
- Trim offset and gain errors in artificial intelligent systems

PIN CONFIGURATION

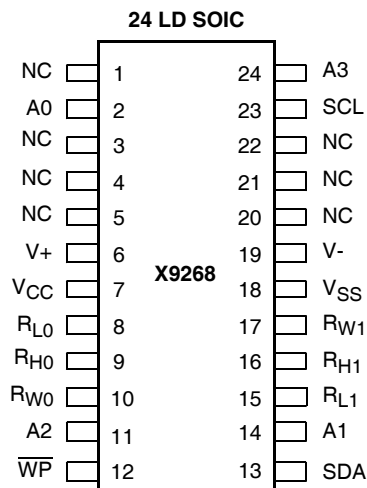

PIN ASSIGNMENTS

Pin (SOIC)	Symbol	Function
1	NC	No Connect
2	A0	Device Address for 2-Wire bus.
3	NC	No Connect
4	NC	No Connect
5	NC	No Connect
6	V+	Analog Supply Pin (Positive)
7	V _{CC}	System Supply Voltage
8	R _{L0}	Low Terminal for Potentiometer 0.
9	R _{H0}	High Terminal for Potentiometer 0.
10	R _{W0}	Wiper Terminal for Potentiometer 0.
11	A2	Device Address for 2-Wire bus.
12	\overline{WP}	Hardware Write Protect
13	SDA	Serial Data Input/Output for 2-Wire bus.
14	A1	Device Address for 2-Wire bus.
15	R _{L1}	Low Terminal for Potentiometer 1.
16	R _{H1}	High Terminal for Potentiometer 1.
17	R _{W1}	Wiper Terminal for Potentiometer 1.
18	V _{SS}	System Ground
19	V-	Analog Supply Pin (Negative)
20	NC	No Connect
21	NC	No Connect
22	NC	No Connect
23	SCL	Serial Clock for 2-Wire bus.
24	A3	Device Address for 2-Wire bus.

PIN DESCRIPTIONS

Bus Interface Pins

SERIAL DATA INPUT/OUTPUT (SDA)

The SDA is a bidirectional serial data input/output pin for a 2-Wire slave device and is used to transfer data into and out of the device. It receives device address, opcode, wiper register address and data sent from an 2-Wire master at the rising edge of the serial clock SCL, and it shifts out data after each falling edge of the serial clock SCL.

It is an open drain output and may be wire-ORed with any number of open drain or open collector outputs. An open drain output requires the use of a pull-up resistor. For selecting typical values, refer to the guidelines for calculating typical values on the bus pull-up resistors graph.

SERIAL CLOCK (SCL)

This input is used by 2-Wire master to supply 2-Wire serial clock to the X9268.

DEVICE ADDRESS (A3 - A0)

The address inputs are used to set the least significant 3 bits of the 8-bit slave address. A match in the slave address serial data stream must be made with the Address input in order to initiate communication with the X9268. A maximum of 8 devices may occupy the 2-Wire serial bus.

Potentiometer Pins

R_H , R_L

The R_H and R_L pins are equivalent to the terminal connections on a mechanical potentiometer. Since there are 2 potentiometers, there are 2 sets of R_H and R_L such that R_{H0} and R_{L0} are the terminals of POT 0 and so on.

R_W

The wiper pin are equivalent to the wiper terminal of a mechanical potentiometer. Since there are 4 potentiometers, there are 2 sets of R_W such that R_{W0} is the terminal of POT 0 and so on.

Bias Supply Pins

SYSTEM SUPPLY VOLTAGE (V_{CC}) AND SUPPLY GROUND (V_{SS})

The V_{CC} pin is the system supply voltage. The V_{SS} pin is the system ground.

Analog Supply Voltages ($V+$ and $V-$)

These supplies are the analog voltage supplies for the potentiometer. The $V+$ supply is tied to the wiper switches while the $V-$ supply is used to bias the switches and the internal P+ substrate of the integrated circuit. Both of these supplies set the voltage limits of the potentiometer.

Other Pins

NO CONNECT

No connect pins should be left open. This pins are used for Intersil manufacturing and testing purposes.

HARDWARE WRITE PROTECT INPUT (\overline{WP})

The \overline{WP} pin when LOW prevents nonvolatile writes to the Data Registers.

PRINCIPLES OF OPERATION

The X9268 is a integrated microcircuit incorporating four resistor arrays and their associated registers and counters and the serial interface logic providing direct communication between the host and the digitally controlled potentiometers. This section provides detail description of the following:

- Resistor Array Description
- Serial Interface Description
- Instruction and Register Description.

Array Description

The X9268 is comprised of a resistor array (See Figure 1). Each array contains 255 discrete resistive segments that are connected in series. The physical ends of each array are equivalent to the fixed terminals of a mechanical potentiometer (R_H and R_L inputs).

At both ends of each array and between each resistor segment is a CMOS switch connected to the wiper (R_W) output. Within each individual array only one switch may be turned on at a time.

These switches are controlled by a Wiper Counter Register (WCR). The 8-bits of the WCR ($WCR[7:0]$) are decoded to select, and enable, one of 256 switches (See Table 1).

The WCR may be written directly. These Data Registers can the WCR can be read and written by the host system.

Power-up and Down Requirements.

At all times, the voltages on the potentiometer pins must be less than V_+ and more than V_- . During power-up and power-down, V_{CC} , V_+ , and V_- must reach their final values within 1msecs of each other. The V_{CC} ramp rate spec is always in effect.

Figure 1. Detailed Potentiometer Block Diagram

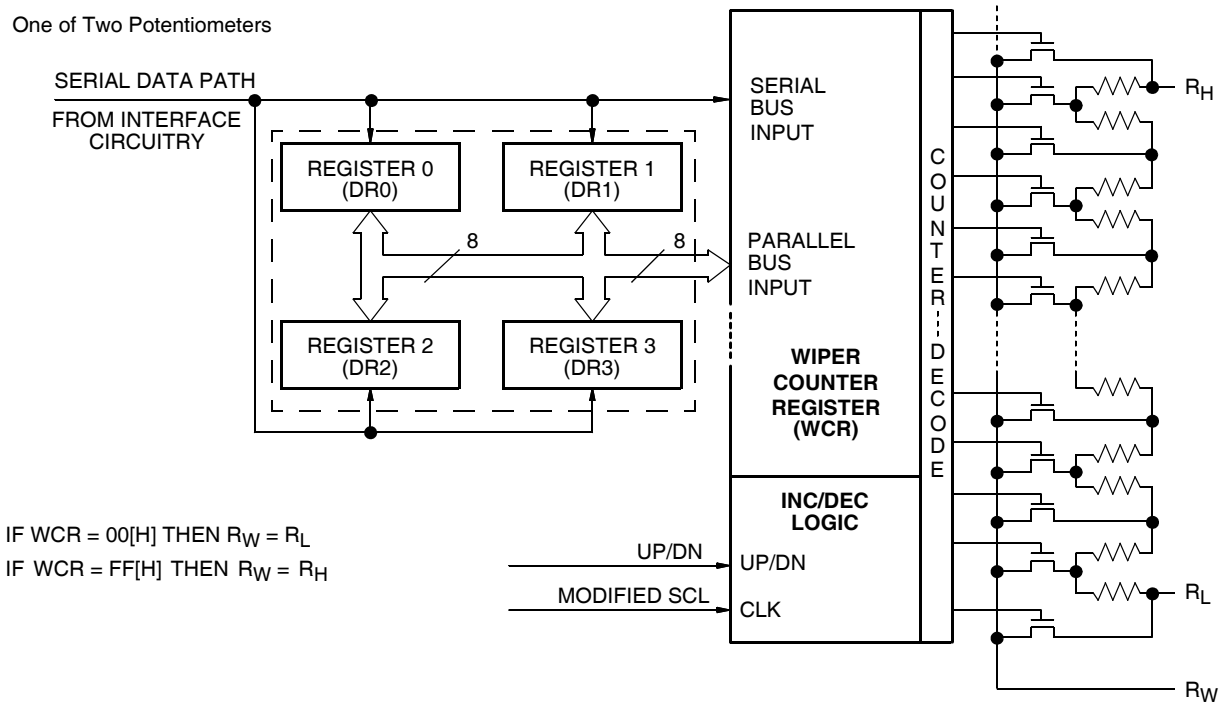

SERIAL INTERFACE DESCRIPTION

Serial Interface

The X9268 supports a bidirectional bus oriented protocol. The protocol defines any device that sends data onto the bus as a transmitter and the receiving device as the receiver. The device controlling the transfer is a master and the device being controlled is the slave. The master will always initiate data transfers and provide the clock for both transmit and receive operations. Therefore, the X9268 will be considered a slave device in all applications.

Clock and Data Conventions

Data states on the SDA line can change only during SCL LOW periods. SDA state changes during SCL HIGH are reserved for indicating start and stop conditions. See Figure 2.

Start Condition

All commands to the X9268 are preceded by the start condition, which is a HIGH to LOW transition of SDA while SCL is HIGH. The X9268 continuously monitors

the SDA and SCL lines for the start condition and will not respond to any command until this condition is met. See Figure 2.

Stop Condition

All communications must be terminated by a stop condition, which is a LOW to HIGH transition of SDA while SCL is HIGH. See Figure 2.

Acknowledge

Acknowledge is a software convention used to provide a positive handshake between the master and slave devices on the bus to indicate the successful receipt of data. The transmitting device, either the master or the slave, will release the SDA bus after transmitting eight bits. The master generates a ninth clock cycle and during this period the receiver pulls the SDA line LOW to acknowledge that it successfully received the eight bits of data.

The X9268 will respond with an acknowledge after recognition of a start condition and its slave address and once again after successful receipt of the command byte. If the command is followed by a data byte the X9268 will respond with a final acknowledge. See Figure 2.

Figure 2. Acknowledge Response from Receiver

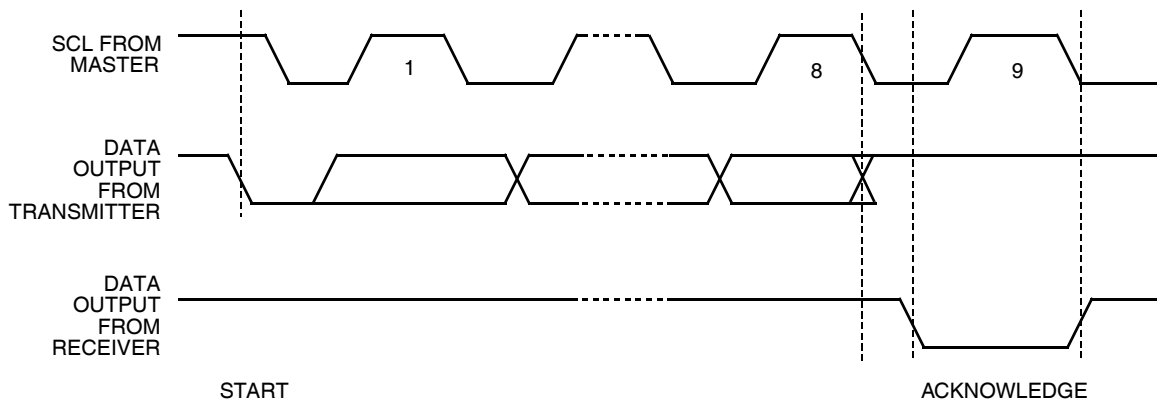

Acknowledge Polling

The disabling of the inputs, during the internal nonvolatile write operation, can be used to take advantage of the typical 5ms nonvolatile write cycle time. Once the stop condition is issued to indicate the end of the nonvolatile write command the X9268 initiates the internal write cycle. ACK polling, Flow 1, can be initiated immediately. This involves issuing the start condition followed by the device slave address. If the X9268 is still busy with the write operation no ACK will be returned. If the X9268 has completed the write operation an ACK will be returned and the master can then proceed with the next operation.

FLOW 1: ACK Polling Sequence

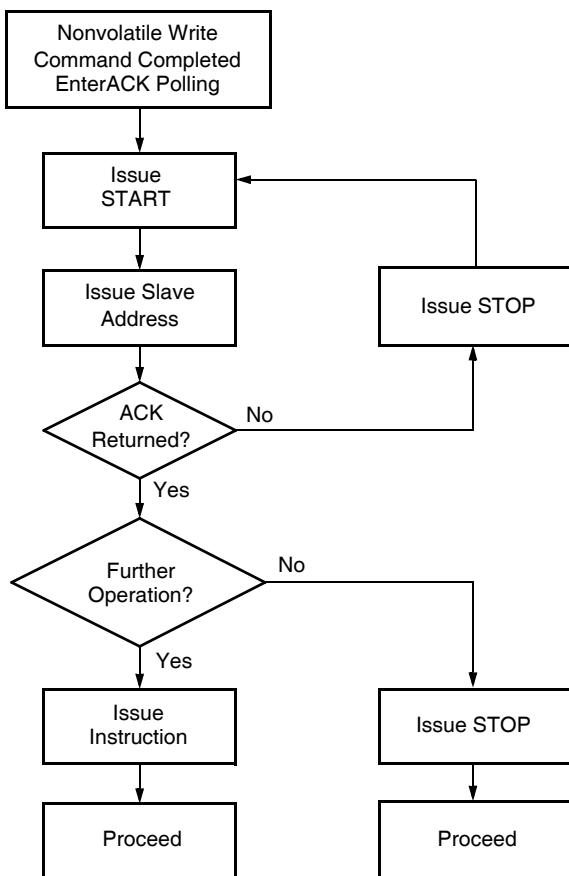

INSTRUCTION AND REGISTER DESCRIPTION

Instructions

DEVICE ADDRESSING: IDENTIFICATION BYTE (ID AND A)

The first byte sent to the X9268 from the host is called the Identification Byte. The most significant four bits of the slave address are a device type identifier. The ID[3:0] bits is the device id for the X9268; this is fixed as 0101[B] (refer to Table 1).

The A[3:0] bits in the ID byte is the internal slave address. The physical device address is defined by the state of the A3 - A0 input pins. The slave address is externally specified by the user. The X9268 compares the serial data stream with the address input state; a successful compare of both address bits is required for the X9268 to successfully continue the command sequence. Only the device which slave address matches the incoming device address sent by the master executes the instruction. The A3 - A0 inputs can be actively driven by CMOS input signals or tied to V_{CC} or V_{SS}.

INSTRUCTION BYTE (I)

The next byte sent to the X9268 contains the instruction and register pointer information. The three most significant bits are used provide the instruction opcode I [3:0]. The RB and RA bits point to one of the four Data Registers of each associated XDCCP. The least significant bit points to one of two Wiper Counter Registers or Pots. The format is shown in Table 2.

Register Selection

Register Selected	RB	RA
DR0	0	0
DR1	0	1
DR2	1	0
DR3	1	1

Table 1. Identification Byte Format

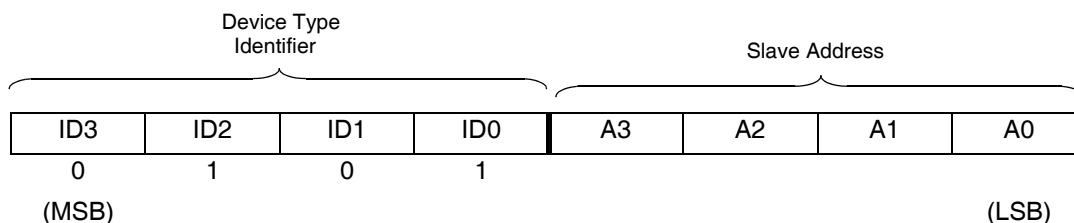

Table 2. Instruction Byte Format

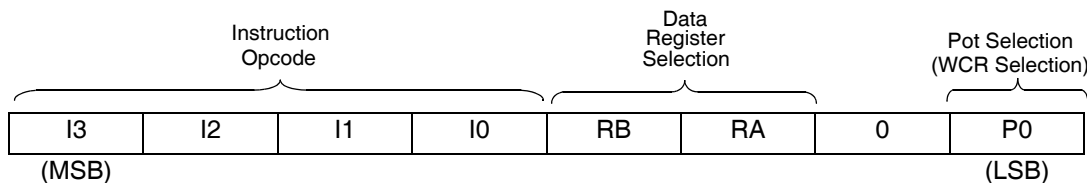

Table 3. Instruction Set

Instruction	Instruction Set								Operation
	I3	I2	I1	I0	RB	RA	0	P0	
Read Wiper Counter Register	1	0	0	1	0	0	0	1/0	Read the contents of the Wiper Counter Register pointed to by P0
Write Wiper Counter Register	1	0	1	0	0	0	0	1/0	Write new value to the Wiper Counter Register pointed to by P0
Read Data Register	1	0	1	1	1/0	1/0	0	1/0	Read the contents of the Data Register pointed to by P0 and RB - RA
Write Data Register	1	1	0	0	1/0	1/0	0	1/0	Write new value to the Data Register pointed to by P0 and RB - RA
XFR Data Register to Wiper Counter Register	1	1	0	1	1/0	1/0	0	1/0	Transfer the contents of the Data Register pointed to by P0 and RB - RA to its associated Wiper Counter Register
XFR Wiper Counter Register to Data Register	1	1	1	0	1/0	1/0	0	1/0	Transfer the contents of the Wiper Counter Register pointed to by P0 to the Data Register pointed to by RB - RA
Global XFR Data Registers to Wiper Counter Registers	0	0	0	1	1/0	1/0	0	0	Transfer the contents of the Data Registers pointed to by RB - RA of all four pots to their respective Wiper Counter Registers
Global XFR Wiper Counter Registers to Data Register	1	0	0	0	1/0	1/0	0	0	Transfer the contents of both Wiper Counter Registers to their respective data Registers pointed to by RB - RA of all four pots
Increment/Decrement Wiper Counter Register	0	0	1	0	0	0	0	1/0	Enable Increment/decrement of the Control Latch pointed to by P0

Note: 1/0 = data is one or zero

DEVICE DESCRIPTION

Wiper Counter Register (WCR)

The X9268 contains two Wiper Counter Registers, one for each DCP potentiometer. The Wiper Counter Register can be envisioned as a 8-bit parallel and serial load counter with its outputs decoded to select one of 256 switches along its resistor array. The contents of the WCR can be altered in four ways: it may be written directly by the host via the Write Wiper Counter Register instruction (serial load); it may be written indirectly by transferring the contents of one of four associated data registers via the XFR Data Register instruction (parallel load); it can be modified one step at a time by the Increment/Decrement instruction (See Instruction section for more details). Finally, it is loaded with the contents of its Data Register zero (DR0) upon power-up.

The Wiper Counter Register is a volatile register; that is, its contents are lost when the X9268 is powered-down. Although the register is automatically loaded

with the value in DR0 upon power-up, this may be different from the value present at power-down. Power-up guidelines are recommended to ensure proper loadings of the DR0 value into the WCR (See Design Considerations Section).

Data Registers (DR)

Each potentiometer has four 8-bit nonvolatile Data Registers. These can be read or written directly by the host. Data can also be transferred between any of the four Data Registers and the associated Wiper Counter Register. All operations changing data in one of the data registers is a nonvolatile operation and will take a maximum of 10ms.

If the application does not require storage of multiple settings for the potentiometer, the Data Registers can be used as regular memory locations for system parameters or user preference data.

Bit [7:0] are used to store one of the 256 wiper positions (0~255).

Table 4. Wiper counter Register, WCR (8-bit), WCR[7:0]: Used to store the current wiper position (Volatile, V).

WCR7	WCR6	WCR5	WCR4	WCR3	WCR2	WCR1	WCR0
V	V	V	V	V	V	V	V
(MSB)							(LSB)

Table 5. Data Register, DR (8-bit), Bit [7:0]: Used to store wiper positions or data (Nonvolatile, NV).

Bit 7	Bit 6	Bit 5	Bit 4	Bit 3	Bit 2	Bit 1	Bit 0
NV	NV	NV	NV	NV	NV	NV	NV
MSB							LSB

DEVICE DESCRIPTION

Instructions

Four of the nine instructions are three bytes in length. These instructions are:

- **Read Wiper Counter Register** – read the current wiper position of the selected potentiometer,
- **Write Wiper Counter Register** – change current wiper position of the selected potentiometer,
- **Read Data Register** – read the contents of the selected Data Register;
- **Write Data Register** – write a new value to the selected Data Register.

The basic sequence of the three byte instructions is illustrated in Figure 4. These three-byte instructions exchange data between the WCR and one of the Data Registers. A transfer from a Data Register to a WCR is essentially a write to a static RAM, with the static RAM controlling the wiper position. The response of the wiper to this action will be delayed by t_{WRL} . A transfer from the WCR (current wiper position), to a Data Register is a write to nonvolatile memory and takes a minimum of t_{WR} to complete. The transfer can occur between one of the four potentiometers and one of its associated registers; or it may occur globally, where the transfer occurs between all potentiometers and one associated register

Four instructions require a two-byte sequence to complete. These instructions transfer data between the host and the X9268; either between the host and one of the data registers or directly between the host and the Wiper Counter Register. These instructions are:

- **XFR Data Register to Wiper Counter Register** – This transfers the contents of one specified Data Register to the associated Wiper Counter Register.
- **XFR Wiper Counter Register to Data Register** – This transfers the contents of the specified Wiper Counter Register to the specified associated Data Register.
- **Global XFR Data Register to Wiper Counter Register** – This transfers the contents of all specified Data Registers to the associated Wiper Counter Registers.
- **Global XFR Wiper Counter Register to Data Register** – This transfers the contents of all Wiper Counter Registers to the specified associated Data Registers.

INCREMENT/DECREMENT COMMAND

The final command is Increment/Decrement (Figure 5 and 6). The Increment/Decrement command is different from the other commands. Once the command is issued and the X9268 has responded with an acknowledge, the master can clock the selected wiper up and/or down in one segment steps; thereby, providing a fine tuning capability to the host. For each SCL clock pulse (t_{HIGH}) while SDA is HIGH, the selected wiper will move one resistor segment towards the R_H terminal. Similarly, for each SCL clock pulse while SDA is LOW, the selected wiper will move one resistor segment towards the R_L terminal.

See Instruction format for more details.

Figure 3. Two-Byte Instruction Sequence

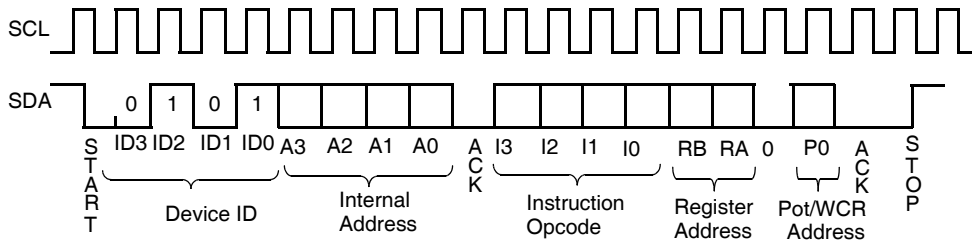

Figure 4. Three-Byte Instruction Sequence

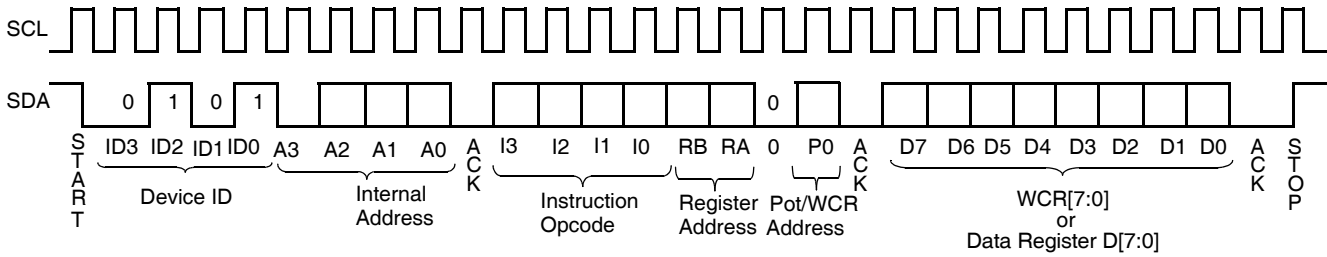

Figure 5. Increment/Decrement Instruction Sequence

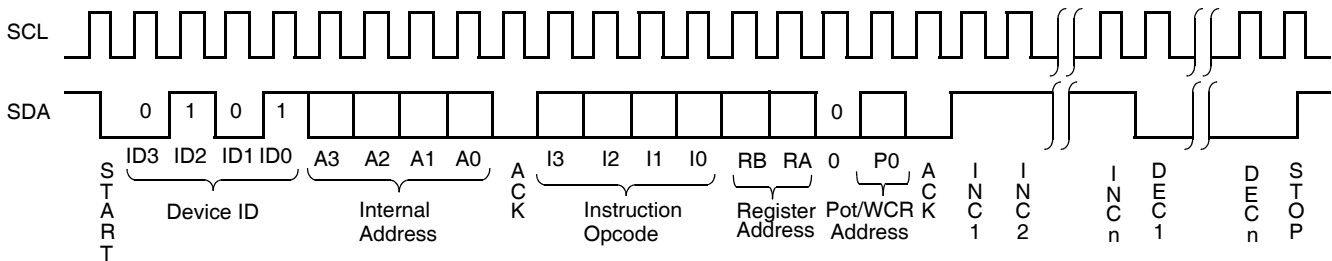
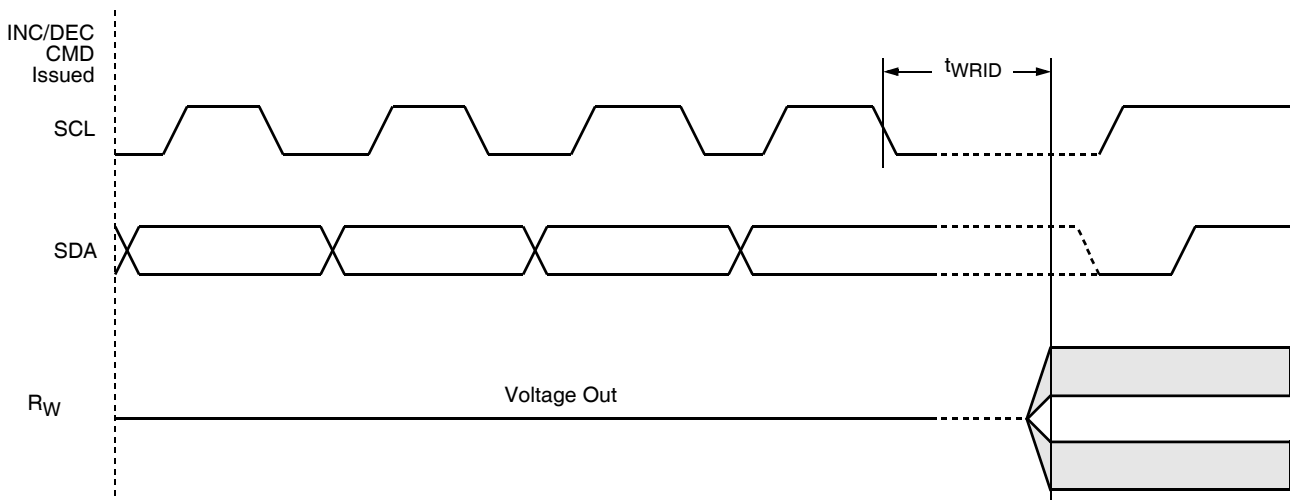

Figure 6. Increment/Decrement Timing Limits



INSTRUCTION FORMAT

Read Wiper Counter Register (WCR)

S T A R T	Device Type Identifier				Device Addresses				S A C K	Instruction Opcode				DR/WCR Addresses				S A C K	Wiper Position (Sent by X9268 on SDA)								M A C K	S T O P
	0	1	0	1	A3	A2	A1	A0		1	0	0	1	0	0	0	P0		W C R 7	W C R 6	W C R 5	W C R 4	W C R 3	W C R 2	W C R 1	W C R 0		
	0	1	0	1	A3	A2	A1	A0		1	0	0	1	0	0	0	P0		W C R 7	W C R 6	W C R 5	W C R 4	W C R 3	W C R 2	W C R 1	W C R 0		

Write Wiper Counter Register (WCR)

S T A R T	Device Type Identifier				Device Addresses				S A C K	Instruction Opcode				DR/WCR Addresses				S A C K	Wiper Position (Sent by Master on SDA)								S A C K	S T O P
	0	1	0	1	A3	A2	A1	A0		1	0	1	0	0	0	0	P0		W C R 7	W C R 6	W C R 5	W C R 4	W C R 3	W C R 2	W C R 1	W C R 0		
	0	1	0	1	A3	A2	A1	A0		1	0	1	0	0	0	0	P0		W C R 7	W C R 6	W C R 5	W C R 4	W C R 3	W C R 2	W C R 1	W C R 0		

Read Data Register (DR)

S T A R T	Device Type Identifier				Device Addresses				S A C K	Instruction Opcode				DR/WCR Addresses				S A C K	Wiper Position (Sent by X9268 on SDA)								M A C K	S T O P
	0	1	0	1	A3	A2	A1	A0		1	0	1	1	RB	RA	0	P0		W C R 7	W C R 6	W C R 5	W C R 4	W C R 3	W C R 2	W C R 1	W C R 0		
	0	1	0	1	A3	A2	A1	A0		1	0	1	1	RB	RA	0	P0		W C R 7	W C R 6	W C R 5	W C R 4	W C R 3	W C R 2	W C R 1	W C R 0		

Write Data Register (DR)

S T A R T	Device Type Identifier				Device Addresses				S A C K	Instruction Opcode				DR/WCR Addresses				S A C K	Wiper Position (Sent by Master on SDA)								S A C K	S T O P	H I G H - V O L T A G E W R I T E C Y C L E
	0	1	0	1	A3	A2	A1	A0		1	1	0	0	RB	RA	0	P0		W C R 7	W C R 6	W C R 5	W C R 4	W C R 3	W C R 2	W C R 1	W C R 0			
	0	1	0	1	A3	A2	A1	A0		1	1	0	0	RB	RA	0	P0		W C R 7	W C R 6	W C R 5	W C R 4	W C R 3	W C R 2	W C R 1	W C R 0			

Global XFR Data Register (DR) to Wiper Counter Register (WCR)

S T A R T	Device Type Identifier				Device Addresses				S A C K	Instruction Opcode				DR/WCR Addresses				S A C K	S T O P
	0	1	0	1	A3	A2	A1	A0		0	0	0	1	RB	RA	0	0		
	0	1	0	1	A3	A2	A1	A0		0	0	0	1	RB	RA	0	0		

Global XFR Wiper Counter Register (WCR) to Data Register (DR)

S T A R T	Device Type Identifier				Device Addresses				S A C K	Instruction Opcode				DR/WCR Addresses				S A C K	S T O P	HIGH-VOLTAGE WRITE CYCLE
	0	1	0	1	A3	A2	A1	A0		1	0	0	0	RB	RA	0	0			
	0	1	0	1	A3	A2	A1	A0		1	0	0	0	RB	RA	0	0			

Transfer Wiper Counter Register (WCR) to Data Register (DR)

S T A R T	Device Type Identifier				Device Addresses				S A C K	Instruction Opcode				DR/WCR Addresses				S A C K	S T O P	HIGH-VOLTAGE WRITE CYCLE
	0	1	0	1	A3	A2	A1	A0		1	1	1	0	RB	RA	0	P0			
	0	1	0	1	A3	A2	A1	A0		1	1	1	0	RB	RA	0	P0			

Transfer Data Register (DR) to Wiper Counter Register (WCR)

S T A R T	Device Type Identifier				Device Addresses				S A C K	Instruction Opcode				DR/WCR Addresses				S A C K	S T O P	
	0	1	0	1	A3	A2	A1	A0		1	1	0	1	RB	RA	0	P0			
	0	1	0	1	A3	A2	A1	A0		1	1	0	1	RB	RA	0	P0			

Increment/Decrement Wiper Counter Register (WCR)

S T A R T	Device Type Identifier				Device Addresses				S A C K	Instruction Opcode				DR/WCR Addresses				Increment/Decrement (Sent by Master on SDA)						S T O P		
	0	1	0	1	A3	A2	A1	A0		0	0	1	0	0	0	0	P0	I/D	I/D		I/D	I/D
	0	1	0	1	A3	A2	A1	A0		0	0	1	0	0	0	0	P0	I/D	I/D	I/D	I/D	

- Notes: (1) "MACK"/"SACK": stands for the acknowledge sent by the master/slave.
 (2) "A3 ~ A0": stands for the device addresses sent by the master.
 (3) "X": indicates that it is a "0" for testing purpose but physically it is a "don't care" condition.
 (4) "I": stands for the increment operation, SDA held high during active SCL phase (high).
 (5) "D": stands for the decrement operation, SDA held low during active SCL phase (high).

ABSOLUTE MAXIMUM RATINGS

Temperature under bias -65°C to +135°C
 Storage temperature -65°C to +150°C
 Voltage on SDA, SCL or any address input
 with respect to V_{SS} -1V to +7V
 Voltage on V+ (referenced to V_{SS}) 10V
 Voltage on V- (referenced to V_{SS}) -10V
 (V+) - (V-) 12V
 Any V_H/R_H V+
 Any V_L/R_L V-
 Lead temperature (soldering, 10s) +300°C
 I_W (10s) ±6mA

COMMENT

Stresses above those listed under “Absolute Maximum Ratings” may cause permanent damage to the device. This is a stress rating only; the functional operation of the device (at these or any other conditions above those listed in the operational sections of this specification) is not implied. Exposure to absolute maximum rating conditions for extended periods may affect device reliability.

RECOMMENDED OPERATING CONDITIONS

Temp	Min.	Max.
Commercial	0°C	+70°C
Industrial	-40°C	+85°C

Device	Supply Voltage (V _{CC}) ⁽⁴⁾ Limits
X9268	5V ±10%
X9268-2.7	2.7V to 5.5V

V+	2.7V to 5.5V
V-	-2.7V to -5.5V

POTENTIOMETER CHARACTERISTICS (Over recommended operating conditions unless otherwise stated.)

Symbol	Parameter	Test Conditions	Min.	Typ.	Max.	Unit
R _{TOTAL}	End to End Resistance	T version		100		kΩ
R _{TOTAL}	End to End Resistance	U version		50		kΩ
	End to end resistance tolerance				±20	%
	Power rating	+25°C, each pot			50	mW
I _W	Wiper current				±3	mA
R _W	Wiper resistance	I _W = ± 1mA, V+ = 3V; V- = -3V			250	Ω
R _W	Wiper resistance	I _W = ± 1mA, V+ = 5V; V- = -5V			150	Ω
V+	Voltage on V+ Pin	X9268	+4.5		+5.5	V
		X9268-2.7	+2.7		+5.5	
V-	Voltage on V- Pin	X9268	-5.5		-4.5	V
		X9268 -2.7	-5.5		-2.7	
V _{TERM}	Voltage on any V _H /R _H or V _L /R _L pin		V-		V+	V
	Noise	Ref: 1kHz		-120		dBV
	Resolution ⁽⁴⁾			0.4		%
	Absolute linearity ⁽¹⁾	V _{w(n)(actual)} - V _{w(n)(expected)}			±1	MI ⁽³⁾
	Relative linearity ⁽²⁾	V _{w(n+1)} - [V _{w(n)} + MI]			±0.6	MI ⁽³⁾
	Temperature coefficient of resistance			±300		ppm/°C
	Ratiometric Temperature Coefficient				±20	ppm/°C
C _H /C _L /C _W	Potentiometer Capacitance	See Circuit #3		10/10/25		pF

- Notes: (1) Absolute linearity is utilized to determine actual wiper voltage versus expected voltage as determined by wiper position when used as a potentiometer.
 (2) Relative linearity is utilized to determine the actual change in voltage between two successive tap positions when used as a potentiometer. It is a measure of the error in step size.
 (3) MI = RTOT / 255 or (R_H - R_L) / 255, single pot
 (4) During power-up V_{CC} > V_H, V_L, and V_W.
 (5) n = 0, 1, 2, ..., 255; m = 0, 1, 2, ..., 254.

D.C. OPERATING CHARACTERISTICS (Over the recommended operating conditions unless otherwise specified.)

Symbol	Parameter	Test Conditions	Min.	Typ.	Max.	Units
I _{CC1}	V _{CC} supply current (active)	f _{SCL} = 400kHz; V _{CC} = +6V; SDA = Open; (for 2-Wire, Active, Read and Volatile Write States only)			3	mA
I _{CC2}	V _{CC} supply current (nonvolatile write)	f _{SCL} = 400kHz; V _{CC} = +6V; SDA = Open; (for 2-Wire, Active, Nonvolatile Write State only)			5	mA
I _{SB}	V _{CC} current (standby)	V _{CC} = +6V; V _{IN} = V _{SS} or V _{CC} ; SDA = V _{CC} ; (for 2-Wire, Standby State only)			5	μA
I _{LI}	Input leakage current	V _{IN} = V _{SS} to V _{CC}			10	μA
I _{LO}	Output leakage current	V _{OUT} = V _{SS} to V _{CC}			10	μA
V _{IH}	Input HIGH voltage		V _{CC} × 0.7		V _{CC} + 1	V
V _{IL}	Input LOW voltage		-1		V _{CC} × 0.3	V
V _{OL}	Output LOW voltage	I _{OL} = 3mA			0.4	V
V _{OH}	Output HIGH voltage					

ENDURANCE AND DATA RETENTION

Parameter	Min.	Units
Minimum endurance	100,000	Data changes per bit per register
Data retention	100	years

CAPACITANCE

Symbol	Test	Max.	Units	Test Conditions
C _{IN/OUT} ⁽⁶⁾	Input / Output capacitance (SDA)	8	pF	V _{OUT} = 0V
C _{IN} ⁽⁶⁾	Input capacitance (SCL, \overline{WP} , A3, A2, A1 and A0)	6	pF	V _{IN} = 0V

POWER-UP TIMING

Symbol	Parameter	Min.	Max.	Units
t _r V _{CC} ⁽⁶⁾	V _{CC} Power-up rate	0.2	50	V/ms
t _{PUR} ⁽⁷⁾	Power-up to initiation of read operation		1	ms

POWER-UP AND DOWN REQUIREMENTS

There are no restrictions on the sequencing of the bias supplies V_{CC}, V₊, and V₋ provided that all three supplies reach their final values within 1msec of each other. At all times, the voltages on the potentiometer pins must be less than V₊ and more than V₋. The recall of the wiper position from nonvolatile memory is not in effect until all supplies reach their final value. The V_{CC} ramp rate spec is always in effect.

A.C. TEST CONDITIONS

Input Pulse Levels	V _{CC} × 0.1 to V _{CC} × 0.9
Input rise and fall times	10ns
Input and output timing level	V _{CC} × 0.5

Notes: (6) This parameter is not 100% tested

(7) t_{PUR} and t_{PUD} are the delays required from the time the (last) power supply (V_{CC-}) is stable until the specific instruction can be issued. These parameters are periodically sampled and not 100% tested.

EQUIVALENT A.C. LOAD CIRCUIT

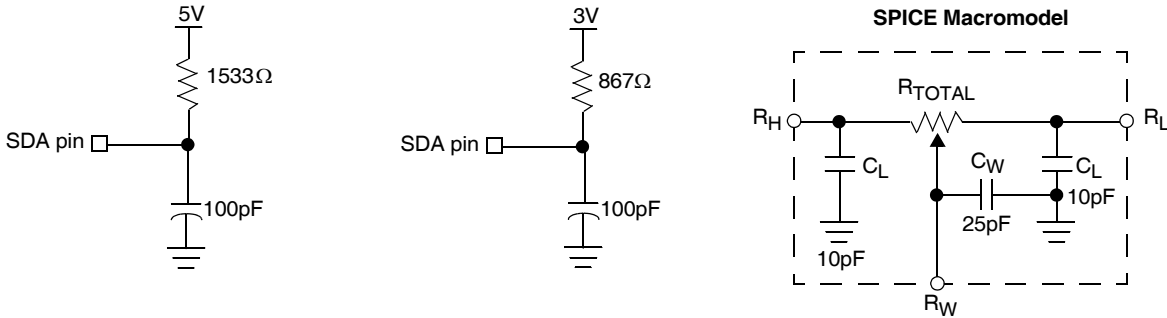

AC TIMING

Symbol	Parameter	Min.	Max.	Units
f _{SCL}	Clock Frequency		400	kHz
t _{CYC}	Clock Cycle Time	2500		ns
t _{HIGH}	Clock High Time	600		ns
t _{LOW}	Clock Low Time	1300		ns
t _{SU:STA}	Start Setup Time	600		ns
t _{HD:STA}	Start Hold Time	600		ns
t _{SU:STO}	Stop Setup Time	600		ns
t _{SU:DAT}	SDA Data Input Setup Time	100		ns
t _{HD:DAT}	SDA Data Input Hold Time	30		ns
t _R	SCL and SDA Rise Time		300	ns
t _F	SCL and SDA Fall Time		300	ns
t _{AA}	SCL Low to SDA Data Output Valid Time		0.9	μs
t _{DH}	SDA Data Output Hold Time	0		ns
T _I	Noise Suppression Time Constant at SCL and SDA inputs	50		ns
t _{BUF}	Bus Free Time (Prior to Any Transmission)	1200		ns
t _{SU:WPA}	A0, A1 Setup Time	0		ns
t _{HD:WPA}	A0, A1 Hold Time	0		ns

HIGH-VOLTAGE WRITE CYCLE TIMING

Symbol	Parameter	Typ.	Max.	Units
t _{WR}	High-voltage write cycle time (store instructions)	5	10	ms

XDCP TIMING

Symbol	Parameter	Min.	Max.	Units
t _{WRPO}	Wiper response time after the third (last) power supply is stable	5	10	μs
t _{WRL}	Wiper response time after instruction issued (all load instructions)	5	10	μs

TIMING DIAGRAMS

Start and Stop Timing

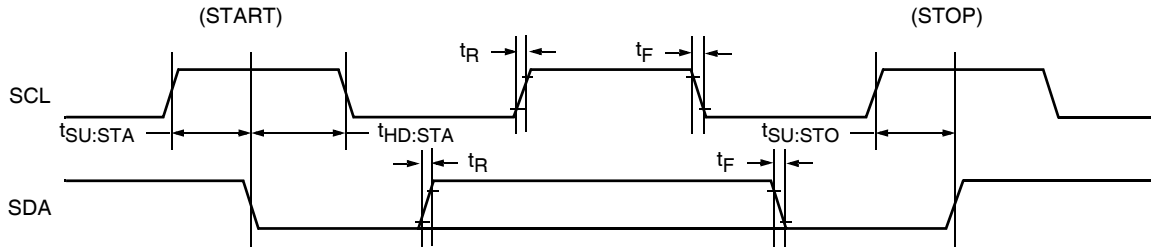

Input Timing

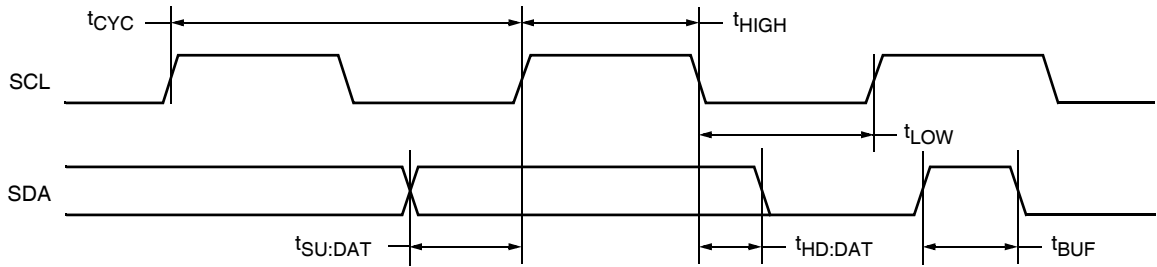

Output Timing

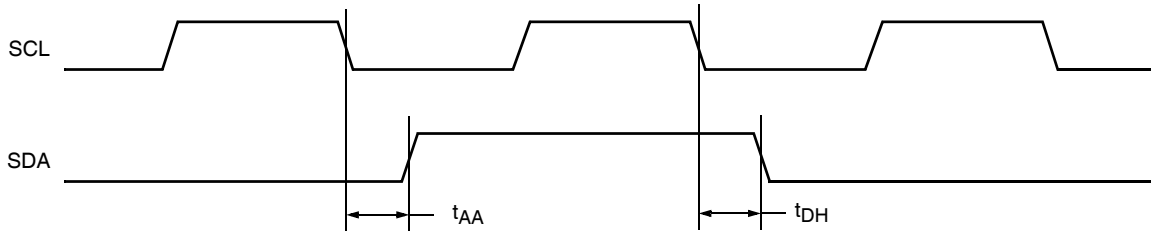

XDCP Timing (for All Load Instructions)

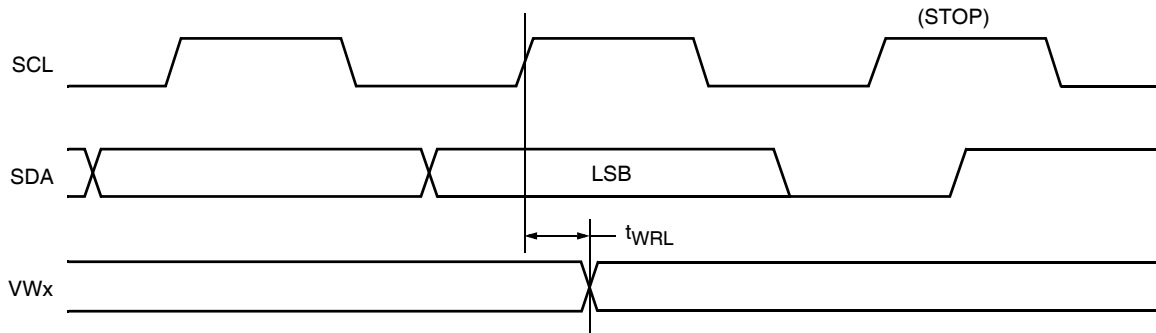

Write Protect and Device Address Pins Timing

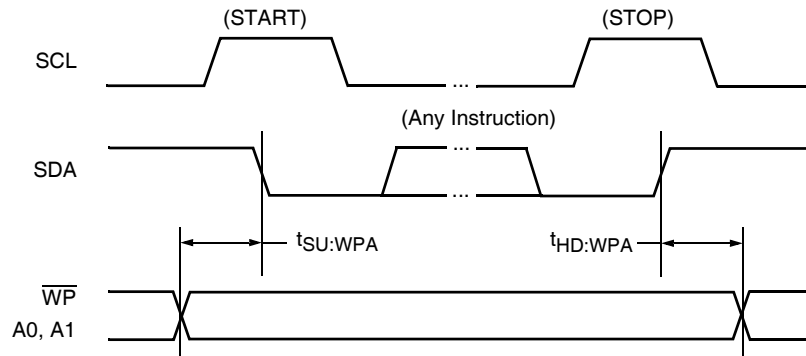

APPLICATIONS INFORMATION

Basic Configurations of Electronic Potentiometers

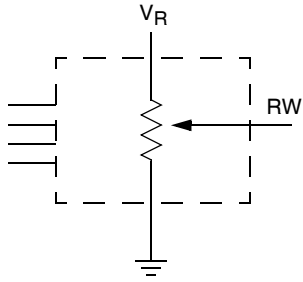

Three terminal Potentiometer;
Variable voltage divider

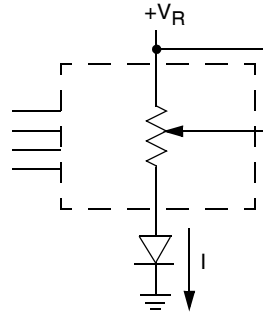

Two terminal Variable Resistor;
Variable current

Application Circuits

Noninverting Amplifier

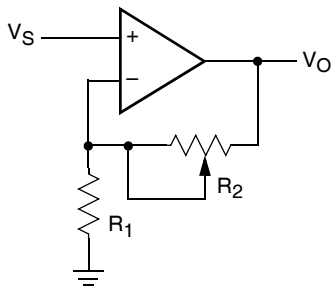

$$V_O = (1 + R_2/R_1) V_S$$

Voltage Regulator

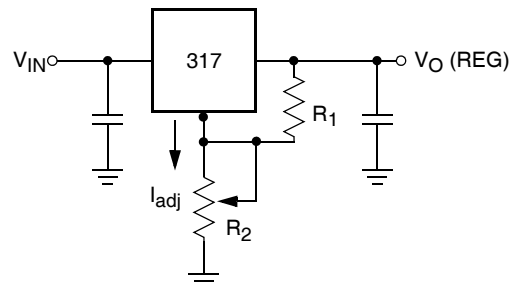

$$V_O (\text{REG}) = 1.25V (1 + R_2/R_1) + I_{adj} R_2$$

Offset Voltage Adjustment

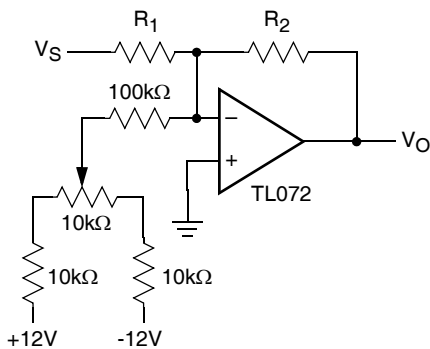

Comparator with Hysteresis

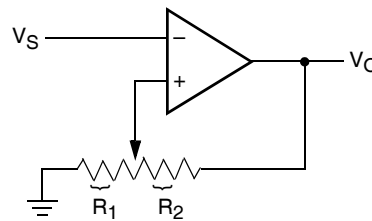

$$V_{UL} = \{R_1 / (R_1 + R_2)\} V_O(\text{max})$$

$$V_{LL} = \{R_1 / (R_1 + R_2)\} V_O(\text{min})$$

Application Circuits (continued)

Attenuator

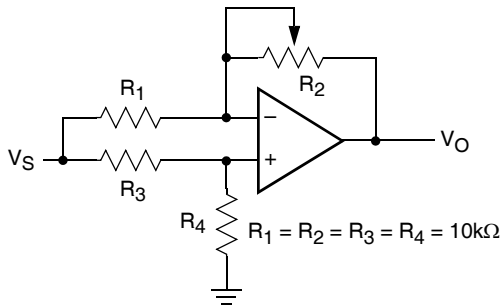

$$V_O = G V_S$$

$$-1/2 \leq G \leq +1/2$$

Filter

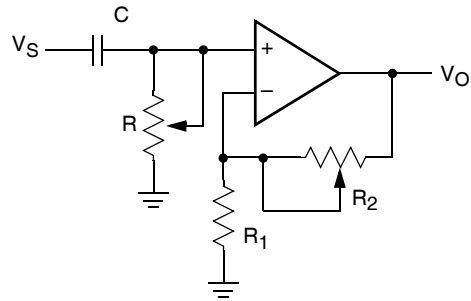

$$G_O = 1 + R_2/R_1$$

$$f_c = 1/(2\pi RC)$$

Inverting Amplifier

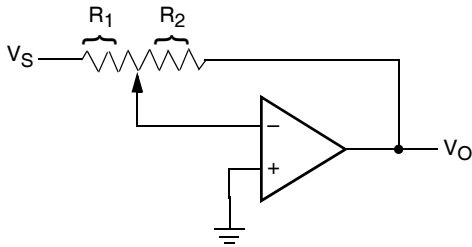

$$V_O = G V_S$$

$$G = -R_2/R_1$$

Equivalent L-R Circuit

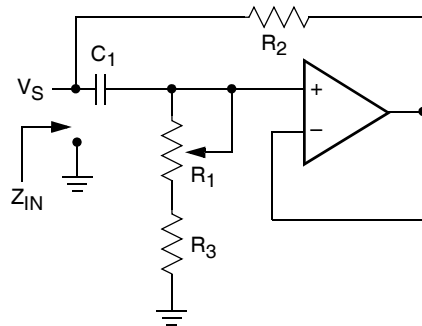

$$Z_{IN} = R_2 + s R_2 (R_1 + R_3) C_1 = R_2 + s L_{eq}$$

$$(R_1 + R_3) \gg R_2$$

Function Generator

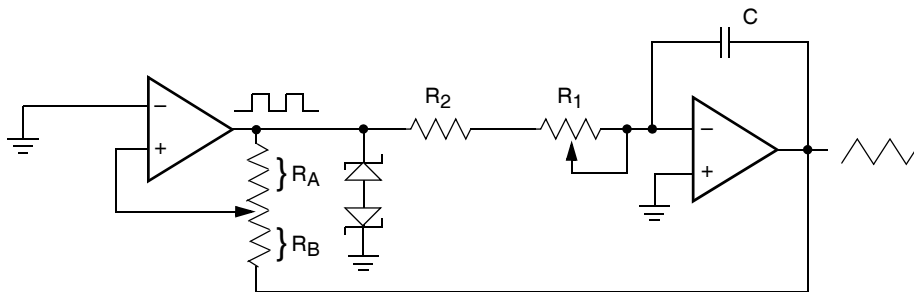

$$\text{frequency} \propto R_1, R_2, C$$

$$\text{amplitude} \propto R_A, R_B$$

Small Outline Plastic Packages (SOIC)

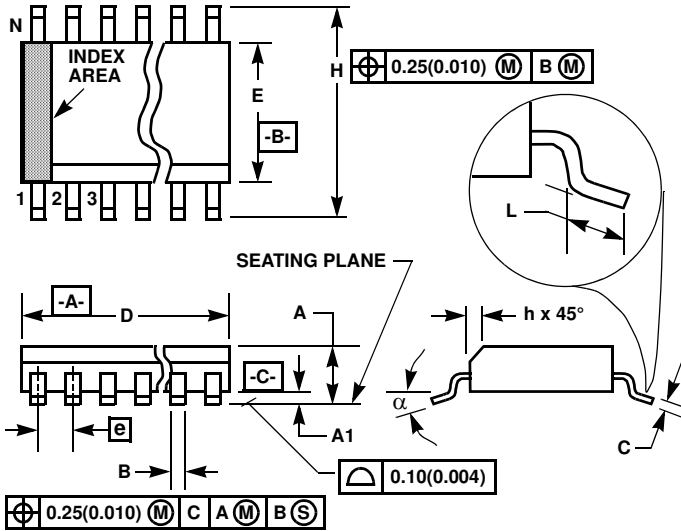

**M24.3 (JEDEC MS-013-AD ISSUE C)
24 LEAD WIDE BODY SMALL OUTLINE PLASTIC PACKAGE**

SYMBOL	INCHES		MILLIMETERS		NOTES
	MIN	MAX	MIN	MAX	
A	0.0926	0.1043	2.35	2.65	-
A1	0.0040	0.0118	0.10	0.30	-
B	0.013	0.020	0.33	0.51	9
C	0.0091	0.0125	0.23	0.32	-
D	0.5985	0.6141	15.20	15.60	3
E	0.2914	0.2992	7.40	7.60	4
e	0.05 BSC		1.27 BSC		-
H	0.394	0.419	10.00	10.65	-
h	0.010	0.029	0.25	0.75	5
L	0.016	0.050	0.40	1.27	6
N	24		24		7
alpha	0°	8°	0°	8°	-

NOTES:

1. Symbols are defined in the "MO Series Symbol List" in Section 2.2 of Publication Number 95.
2. Dimensioning and tolerancing per ANSI Y14.5M-1982.
3. Dimension "D" does not include mold flash, protrusions or gate burrs. Mold flash, protrusion and gate burrs shall not exceed 0.15mm (0.006 inch) per side.
4. Dimension "E" does not include interlead flash or protrusions. Interlead flash and protrusions shall not exceed 0.25mm (0.010 inch) per side.
5. The chamfer on the body is optional. If it is not present, a visual index feature must be located within the crosshatched area.
6. "L" is the length of terminal for soldering to a substrate.
7. "N" is the number of terminal positions.
8. Terminal numbers are shown for reference only.
9. The lead width "B", as measured 0.36mm (0.014 inch) or greater above the seating plane, shall not exceed a maximum value of 0.61mm (0.024 inch)
10. Controlling dimension: MILLIMETER. Converted inch dimensions are not necessarily exact.

Rev. 1 4/06

All Intersil U.S. products are manufactured, assembled and tested utilizing ISO9000 quality systems. Intersil Corporation's quality certifications can be viewed at www.intersil.com/design/quality

Intersil products are sold by description only. Intersil Corporation reserves the right to make changes in circuit design, software and/or specifications at any time without notice. Accordingly, the reader is cautioned to verify that data sheets are current before placing orders. Information furnished by Intersil is believed to be accurate and reliable. However, no responsibility is assumed by Intersil or its subsidiaries for its use; nor for any infringements of patents or other rights of third parties which may result from its use. No license is granted by implication or otherwise under any patent or patent rights of Intersil or its subsidiaries.

For information regarding Intersil Corporation and its products, see www.intersil.com