



Chipsmall Limited consists of a professional team with an average of over 10 year of expertise in the distribution of electronic components. Based in Hongkong, we have already established firm and mutual-benefit business relationships with customers from,Europe,America and south Asia,supplying obsolete and hard-to-find components to meet their specific needs.

With the principle of “Quality Parts,Customers Priority,Honest Operation,and Considerate Service”,our business mainly focus on the distribution of electronic components. Line cards we deal with include Microchip,ALPS,ROHM,Xilinx,Pulse,ON,Everlight and Freescale. Main products comprise IC,Modules,Potentiometer,IC Socket,Relay,Connector.Our parts cover such applications as commercial,industrial, and automotives areas.

We are looking forward to setting up business relationship with you and hope to provide you with the best service and solution. Let us make a better world for our industry!



Contact us

Tel: +86-755-8981 8866 Fax: +86-755-8427 6832

Email & Skype: info@chipsmall.com Web: www.chipsmall.com

Address: A1208, Overseas Decoration Building, #122 Zhenhua RD., Futian, Shenzhen, China



**Linear, 32 Taps, Push Button Controlled,
Terminal Voltage ±5V**
FEATURES

- **Push button controlled**
- **Low power CMOS**
 - Active current, 3mA max
 - Standby current, 100µA typical
- **31 resistive elements**
 - Temperature compensated
 - ±20% end to end resistance range
 - 5V to +5V range
- **32 wiper tap points**
 - Wiper positioned via two push button inputs
 - Slow and fast scan modes
 - AUTOSTORE® option
 - Manual store option
 - Wiper position stored in nonvolatile memory and recalled on power-up
- **100 year wiper position data retention**
- **X9511W = 10kΩ**
- **Packages**
 - 8 Ld PDIP
 - 8 Ld SOIC
- **Pb-free plus anneal available (RoHS compliant)**

DESCRIPTION

The Intersil X9511 is a push button controlled potentiometer that is ideal for push button controlled resistance trimming.

The X9511 is a resistor array composed of 31 resistive elements. Between each element and at either end are tap points accessible to the wiper element. The position of the wiper element is controlled by the PU and PD inputs. The position of the wiper can be automatically stored in E² memory and then be recalled upon a subsequent power-on operation.

The resolution of the X9511 is equal to the maximum resistance value divided by 31. As an example, for the X9511W (10kΩ) each tap point represents 323Ω.

All Intersil nonvolatile products are designed and tested for applications requiring extended endurance and data retention.

ORDERING INFORMATION

PART NUMBER	PART MARKING	R _{TOTAL} (kΩ)	TEMPERATURE RANGE (°C)	PACKAGE	PKG. DWG. #
X9511WP	X9511WP	10	0 to +70	8 Ld PDIP	MDP0031
X9511WPZ (Note)	X9511WP Z		0 to +70	8 Ld PDIP*** (Pb-free)	MDP0031
X9511WPI	X9511WP I		-40 to +85	8 Ld PDIP	MDP0031
X9511WPIZ (Note)	X9511WP Z I		-40 to +85	8 Ld PDIP*** (Pb-free)	MDP0031
X9511WS**	X9511W		0 to +70	8 Ld SOIC	MDP0027
X9511WSZ*, **(Note)	X9511W Z		0 to +70	8 Ld SOIC (Pb-free)	MDP0027
X9511WSI*, **	X9511W I		-40 to +85	8 Ld SOIC	MDP0027
X9511WSIZ*, ** (Note)	X9511W Z I		-40 to +85	8 Ld SOIC (Pb-free)	MDP0027

NOTE: Intersil Pb-free plus anneal products employ special Pb-free material sets; molding compounds/die attach materials and 100% matte tin plate termination finish, which are RoHS compliant and compatible with both SnPb and Pb-free soldering operations. Intersil Pb-free products are MSL classified at Pb-free peak reflow temperatures that meet or exceed the Pb-free requirements of IPC/JEDEC J STD-020.

*Add "T1" suffix for tape and reel.

**Add "T2" suffix for tape and reel.

***Pb-free PDIPs can be used for through hole wave solder processing only. They are not intended for use in Reflow solder processing applications.

BLOCK DIAGRAM

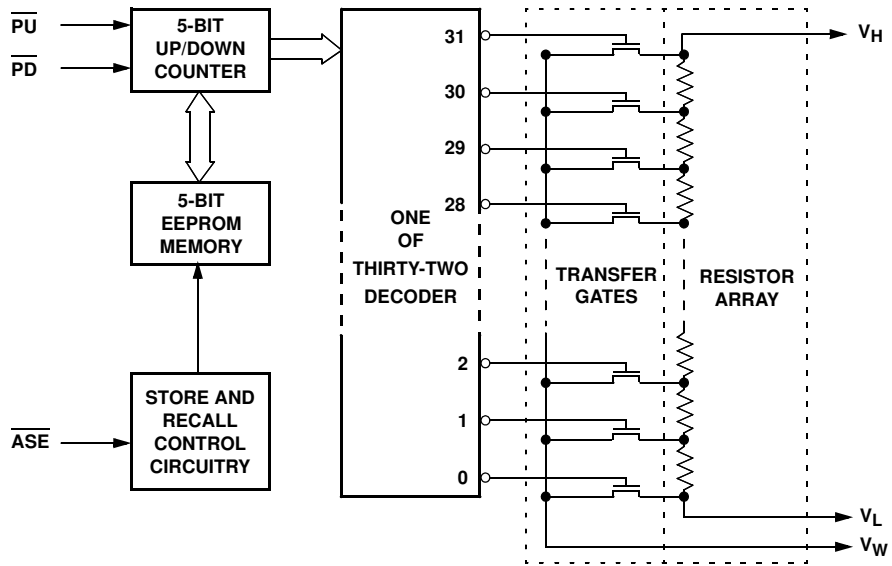

PIN DESCRIPTIONS

V_H/R_H and V_L/R_L

The high (V_H/R_H) and low (V_L/R_L) terminals of the X9511 are equivalent to the fixed terminals of a mechanical potentiometer. The minimum voltage is -5V and the maximum is +5V. It should be noted that the terminology of V_L/R_L and V_H/R_H are in reference to the relative position of the terminal in relation to wiper movement direction selected by the PU and PD inputs, and not the voltage potential on the terminal.

$\overline{\text{PU}}$

The debounced $\overline{\text{PU}}$ input is for incrementing the wiper position. An on-chip pull-up holds the $\overline{\text{PU}}$ input HIGH. A switch closure to ground or a LOW logic level will, after a debounce time, move the wiper to the next adjacent higher tap position.

$\overline{\text{PD}}$

The debounced $\overline{\text{PD}}$ input is for decrementing the wiper position. An on-chip pull-up holds the $\overline{\text{PD}}$ input HIGH. A switch closure to ground or a LOW logic level will, after a debounce time, move the wiper to the next adjacent lower tap position.

$\overline{\text{ASE}}$

The debounced $\overline{\text{ASE}}$ (AUTOSTORE enable) pin can be in one of two states:

V_{IL} - AUTOSTORE is enabled. When V_{CC} powers down, an automatic store cycle takes place.

V_{IH} - AUTOSTORE is disabled. A LOW to HIGH will initiate a manual store operation. This is for the user who wishes to connect a push button switch to this pin. For every valid push, the X9511 will store the current wiper position to the EEPROM.

PIN CONFIGURATION

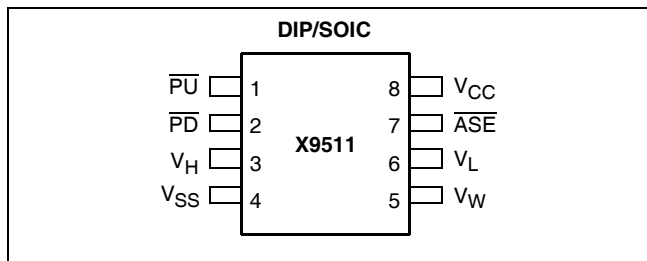

PIN NAMES

SYMBOL	DESCRIPTION
V _H /R _H	High Terminal
V _W /R _W	Wiper Terminal
V _L /R _L	Low Terminal
V _{SS}	Ground
V _{CC}	Supply Voltage
$\overline{\text{PU}}$	Push Up Input
$\overline{\text{PD}}$	Push Down Input
$\overline{\text{ASE}}$	AUTOSTORE Enable Input

DEVICE OPERATION

There are three sections of the X9511: the input control, counter and decode section; the EEPROM memory; and the resistor array. The input control section operates just like an up/down counter. The output of this counter is decoded to turn on a single electronic switch, connecting a point on the resistor array to the wiper output. Under the proper conditions the contents of the counter can be stored in EEPROM memory and retained for future use. The resistor array is comprised of 31 individual resistors connected in series. At either end of the array and between each resistor is an electronic switch that transfers the potential at that point to the wiper.

The X9511 is designed to interface directly to two push button switches for effectively moving the wiper up or down. The $\overline{\text{PU}}$ and $\overline{\text{PD}}$ inputs increment or decrement a 5-bit counter respectively. The output of this counter is decoded to select one of the thirty-two wiper positions along the resistive array. The wiper increment input, $\overline{\text{PU}}$ and the wiper decrement input, $\overline{\text{PD}}$ are both connected to an internal pull-up so that they normally remain HIGH. When pulled LOW by an external push button switch or a logic LOW level input, the wiper will be switched to the next adjacent tap position.

Internal debounce circuitry prevents inadvertent switching of the wiper position if $\overline{\text{PU}}$ or $\overline{\text{PD}}$ remain LOW for less than 40ms, typical. Each of the buttons can be pushed either once for a single increment/decrement or continuously for a multiple increments/decrements. The number of increments/decrements of the wiper position depend on how long the button is being pushed. When making a continuous push, after the first second, the increment/decrement speed increases. For the first second the device will be in the slow scan mode. Then if the button is held for longer than 1 second the device will go into the fast scan mode. As soon as the button is released the X9511 will return to a standby condition.

The wiper, when at either fixed terminal, acts like its mechanical equivalent and does not move beyond the last position. That is, the counter does not wrap around when clocked to either extreme.

AUTOSTORE

The value of the counter is stored in EEPROM memory whenever the chip senses a power-down of V_{CC} while \overline{ASE} is enabled (held LOW). When power is restored, the content of the memory is recalled and the counter reset to the last value stored.

If AUTOSTORE is to be implemented, \overline{ASE} is typically hard wired to V_{SS} . If \overline{ASE} is held HIGH during power-up and then taken LOW, the wiper will not respond to the \overline{PU} or \overline{PD} inputs until \overline{ASE} is brought HIGH and held HIGH.

Manual (Push Button) Store

When \overline{ASE} is not enabled (held HIGH) a push button switch may be used to pull \overline{ASE} LOW and released to perform a manual store of the wiper position.

R_{TOTAL} with V_{CC} Removed

The end to end resistance of the array will fluctuate once V_{CC} is removed.

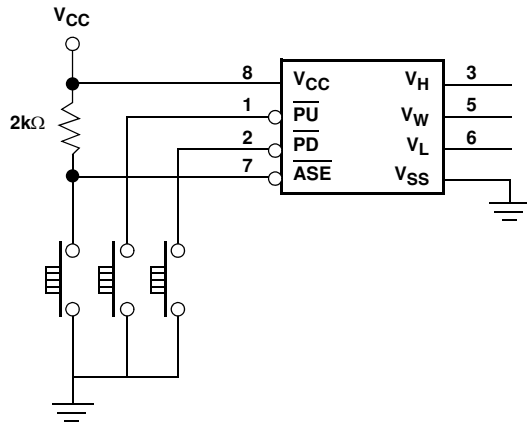

FIGURE 1. TYPICAL CIRCUIT WITH \overline{ASE} STORE CONTROLLED BY PUSH BUTTON SWITCH

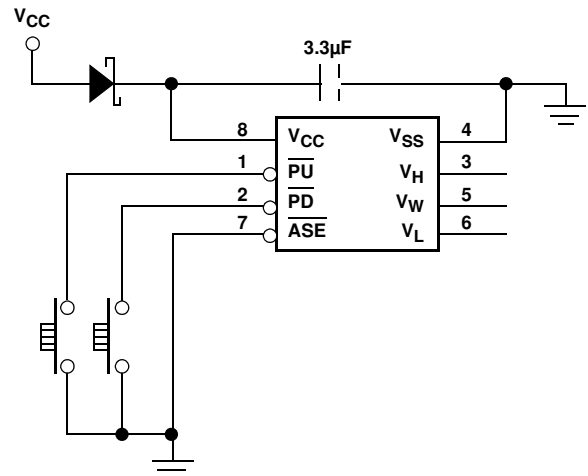

FIGURE 2. TYPICAL CIRCUIT WITH \overline{ASE} STORE PIN USED IN AUTOSTORE MODE

ABSOLUTE MAXIMUM RATINGS

Temperature under bias -65°C to +135°C
 Storage temperature..... -65°C to +150°C
 Voltage on \overline{PU} , \overline{PD} , and V_{CC}
 with respect to V_{SS} -1V to +7V
 Voltage on V_H and V_L
 referenced to V_{SS} -8V to +8V
 $\Delta V = |V_H - V_L|$
 X9511W 10V
 Lead temperature (soldering 10 seconds)..... +300°C
 Wiper current ± 1 mA
 ESD Rating
 Human Body Model
 (Per MIL-STD-883 Method 3015.7) 2.5kV
 Machine Model
 (Per EIAJ ED-4701 Method C-111)..... 250V

ANALOG CHARACTERISTICS

Electrical Characteristics

End-to-end resistance tolerance $\pm 20\%$
 Power rating at +25°C
 X9511W 10mW
 Wiper current ± 1 mA Max.
 Typical wiper resistance 40Ω
 Typical noise..... < -120 dB/√Hz Ref: 1V

Resolution

Resistance 3%

- Notes:** (1) Absolute linearity is utilized to determine actual wiper voltage versus expected voltage = $[V_{W(n)} - (n \cdot MI + V_{W(0)})] / MI = \pm 1$ MI Maximum.
 (2) 1 MI = Minimum Increment = $R_{TOT} / 31$ for resistor mode or $1MI = [V_{W(31)} - V_{W(0)}] / 31$ for voltage divider mode.
 (3) Relative linearity is a measure of the error in step size between taps = $(V_{W(n+1)} - V_{W(n)}) / MI - 1 = \pm 0.2$ MI

Linearity

Absolute linearity⁽¹⁾ ± 1.0 MI⁽²⁾
 Relative linearity⁽³⁾ ± 0.2 MI⁽²⁾

COMMENT

Stresses above those listed under “Absolute Maximum Ratings” may cause permanent damage to the device. This is a stress rating only; functional operation of the device (at these or any other conditions above those listed in the operational sections of this specification) is not implied. Exposure to absolute maximum rating conditions for extended periods may affect device reliability.

Temperature Coefficient

-40°C to +85°C
 X9511W +300 ppm/°C Typical
 Ratiometric temperature coefficient ± 20 ppm

Wiper Adjustability

Unlimited wiper adjustment (Non-Store operation)
 Wiper position store operations..... 100,000 data changes

Physical Characteristics

- Marking Includes
 Manufacturer’s Trademark
 Resistance Value or Code
 Date Code

SYMBOL TABLE

WAVEFORM	INPUTS	OUTPUTS
	Must be steady	Will be steady
	May change from Low to High	Will change from Low to High
	May change from High to Low	Will change from High to Low
	Don't Care: Changes Allowed	Changing: State Not Known
	N/A	Center Line is High Impedance

RECOMMENDED OPERATING CONDITIONS

Temp	Min.	Max.
Commercial	0×C	+70°C
Industrial	-40×C	+85°C

Supply Voltage	Limits
X9511	5V ± 10%

D.C. OPERATING CHARACTERISTICS (Over recommended operating conditions unless otherwise specified.)

Symbol	Parameter	Limits			Unit	Test Conditions
		Min.	Typ. ⁽⁴⁾	Max.		
I _{CC}	V _{CC} active current		1	3	mA	\overline{PU} or \overline{PD} held at V _{IL} the other at V _{IH}
I _{SB}	Standby supply current		100	500	μA	$\overline{PU} = \overline{PD} = V_{IH}$
I _{LI}	\overline{PU} , \overline{PD} , \overline{ASE} input leakage current			10	μA	V _{IN} = V _{SS} to V _{CC}
V _{IH}	\overline{PU} , \overline{PD} , \overline{ASE} input HIGH voltage	2			V	
V _{IL}	\overline{PU} , \overline{PD} , \overline{ASE} input LOW voltage			0.8	V	
R _W	Wiper resistance		40	100	W	Wiper Current V _{CC} /R _{TOT}
V _{VH}	VH terminal voltage	-5		+5	V	
V _{VL}	VL terminal voltage	-5		+5	V	
C _{IN} ⁽⁵⁾	\overline{ASE} , \overline{PU} , \overline{PD} input capacitance		10		pF	V _{CC} = 5V, V _{IN} = 0V, T _A = +25°C, f = 1MHz

A.C. OPERATING CHARACTERISTICS (Over recommended operating conditions unless otherwise specified.)

Symbol	Parameter	Limits			Unit
		Min.	Typ. ⁽⁴⁾	Max.	
t _{GAP}	Time between two separate push button events	50			μs
t _{DB}	Debounce time		30	40	ms
t _{S SLOW}	After debounce to wiper change on a slow mode	100	250	375	ms
t _{S FAST}	Wiper change on a fast mode	25	50	90	ms
t _{PU}	Power-up to wiper stable			500	μs
t _{R VCC}	V _{CC} power-up rate	0.2		50	V/ms
t _{ASTO} ⁽⁵⁾	AUTOSTORE cycle time	2			ms
V _{ASTH} ⁽⁵⁾	AUTOSTORE threshold voltage		4		V
V _{ASEND} ⁽⁵⁾	AUTOSTORE cycle end voltage		3.5		V

POWER-UP AND POWER-DOWN REQUIREMENTS

The are no restrictions on the sequencing of V_{CC} and the voltage applied to the potentiometer pins during power-up or power-down conditions. During power-up, the data sheet parameters for the DCP do not fully apply until 1ms after V_{CC} reaches its final value. The V_{CC} ramp rate spec is always in effect.

AUTOSTORE Cycle Timing Diagram

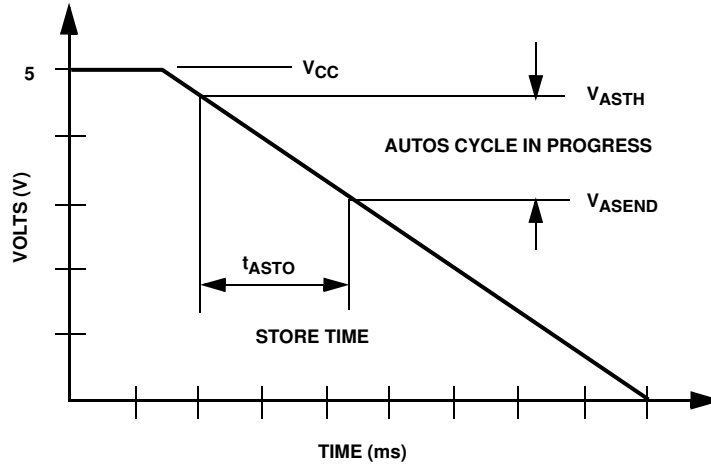

- Notes:** V_{ASTH} - AUTOSTORE threshold voltage
 V_{ASEND} - AUTOSTORE cycle end voltage
 t_{ASTO} - AUTOSTORE cycle time
 (4) Typical values are for $T_A = +25^\circ\text{C}$ and nominal supply voltage.
 (5) This parameter is periodically sampled and not 100% tested.

Slow Mode Timing

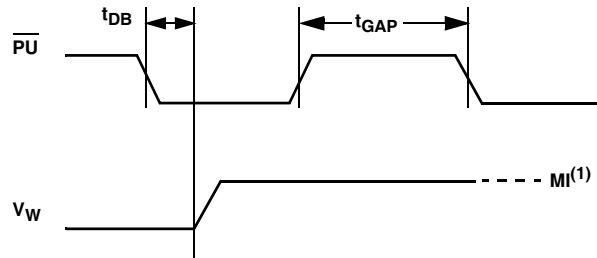

Note: (1) MI in the A.C. timing diagram refers to the minimum incremental change in the wiper voltage.

Fast Mode Timing

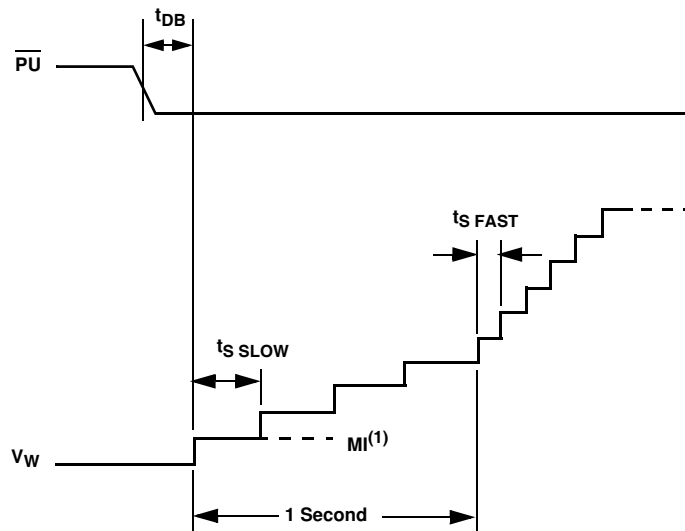

Note: (1) MI in the A.C. timing diagram refers to the minimum incremental change in the wiper voltage.

Plastic Dual-In-Line Packages (PDIP)

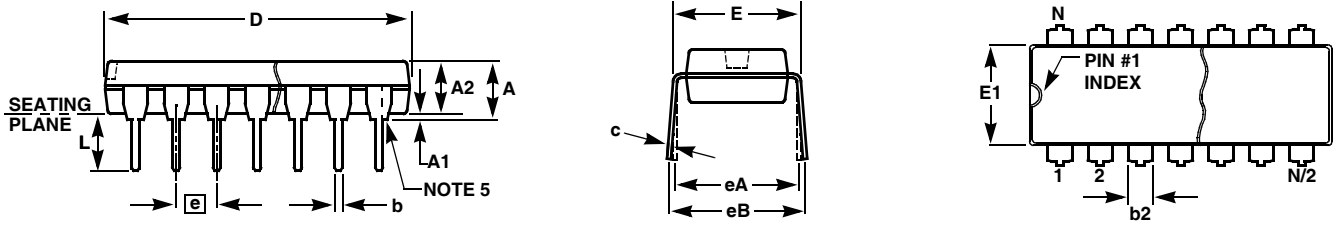

MDP0031

PLASTIC DUAL-IN-LINE PACKAGE

SYMBOL	PDIP8	PDIP14	PDIP16	PDIP18	PDIP20	TOLERANCE	NOTES
A	0.210	0.210	0.210	0.210	0.210	MAX	
A1	0.015	0.015	0.015	0.015	0.015	MIN	
A2	0.130	0.130	0.130	0.130	0.130	±0.005	
b	0.018	0.018	0.018	0.018	0.018	±0.002	
b2	0.060	0.060	0.060	0.060	0.060	+0.010/-0.015	
c	0.010	0.010	0.010	0.010	0.010	+0.004/-0.002	
D	0.375	0.750	0.750	0.890	1.020	±0.010	1
E	0.310	0.310	0.310	0.310	0.310	+0.015/-0.010	
E1	0.250	0.250	0.250	0.250	0.250	±0.005	2
e	0.100	0.100	0.100	0.100	0.100	Basic	
eA	0.300	0.300	0.300	0.300	0.300	Basic	
eB	0.345	0.345	0.345	0.345	0.345	±0.025	
L	0.125	0.125	0.125	0.125	0.125	±0.010	
N	8	14	16	18	20	Reference	

Rev. B 2/99

NOTES:

1. Plastic or metal protrusions of 0.010" maximum per side are not included.
2. Plastic interlead protrusions of 0.010" maximum per side are not included.
3. Dimensions E and eA are measured with the leads constrained perpendicular to the seating plane.
4. Dimension eB is measured with the lead tips unconstrained.
5. 8 and 16 lead packages have half end-leads as shown.

Small Outline Package Family (SO)

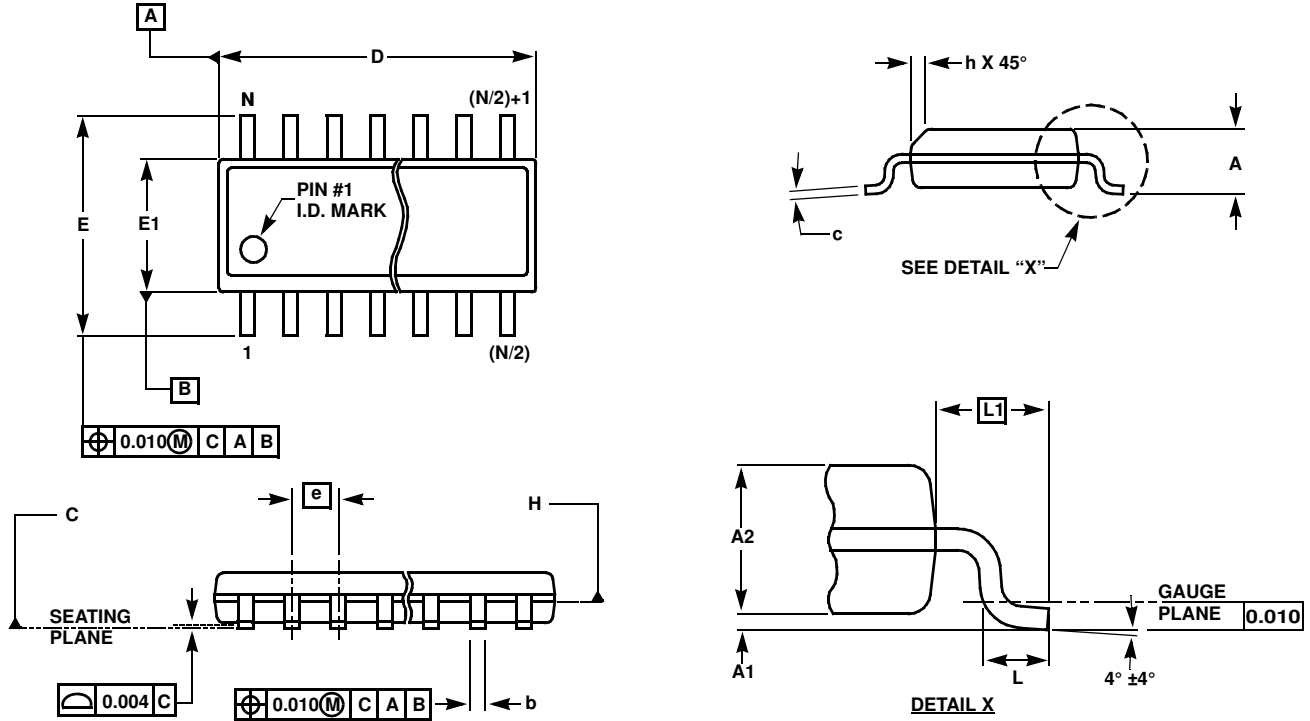

MDP0027

SMALL OUTLINE PACKAGE FAMILY (SO)

SYMBOL	SO-8	SO-14	SO16 (0.150")	SO16 (0.300") (SOL-16)	SO20 (SOL-20)	SO24 (SOL-24)	SO28 (SOL-28)	TOLERANCE	NOTES
A	0.068	0.068	0.068	0.104	0.104	0.104	0.104	MAX	-
A1	0.006	0.006	0.006	0.007	0.007	0.007	0.007	±0.003	-
A2	0.057	0.057	0.057	0.092	0.092	0.092	0.092	±0.002	-
b	0.017	0.017	0.017	0.017	0.017	0.017	0.017	±0.003	-
c	0.009	0.009	0.009	0.011	0.011	0.011	0.011	±0.001	-
D	0.193	0.341	0.390	0.406	0.504	0.606	0.704	±0.004	1, 3
E	0.236	0.236	0.236	0.406	0.406	0.406	0.406	±0.008	-
E1	0.154	0.154	0.154	0.295	0.295	0.295	0.295	±0.004	2, 3
e	0.050	0.050	0.050	0.050	0.050	0.050	0.050	Basic	-
L	0.025	0.025	0.025	0.030	0.030	0.030	0.030	±0.009	-
L1	0.041	0.041	0.041	0.056	0.056	0.056	0.056	Basic	-
h	0.013	0.013	0.013	0.020	0.020	0.020	0.020	Reference	-
N	8	14	16	16	20	24	28	Reference	-

Rev. L 2/01

NOTES:

1. Plastic or metal protrusions of 0.006" maximum per side are not included.
2. Plastic interlead protrusions of 0.010" maximum per side are not included.
3. Dimensions "D" and "E1" are measured at Datum Plane "H".
4. Dimensioning and tolerancing per ASME Y14.5M-1994

All Intersil U.S. products are manufactured, assembled and tested utilizing ISO9000 quality systems.
Intersil Corporation's quality certifications can be viewed at www.intersil.com/design/quality

Intersil products are sold by description only. Intersil Corporation reserves the right to make changes in circuit design, software and/or specifications at any time without notice. Accordingly, the reader is cautioned to verify that data sheets are current before placing orders. Information furnished by Intersil is believed to be accurate and reliable. However, no responsibility is assumed by Intersil or its subsidiaries for its use; nor for any infringements of patents or other rights of third parties which may result from its use. No license is granted by implication or otherwise under any patent or patent rights of Intersil or its subsidiaries.

For information regarding Intersil Corporation and its products, see www.intersil.com