



Chipsmall Limited consists of a professional team with an average of over 10 year of expertise in the distribution of electronic components. Based in Hongkong, we have already established firm and mutual-benefit business relationships with customers from,Europe,America and south Asia,supplying obsolete and hard-to-find components to meet their specific needs.

With the principle of “Quality Parts,Customers Priority,Honest Operation,and Considerate Service”,our business mainly focus on the distribution of electronic components. Line cards we deal with include Microchip,ALPS,ROHM,Xilinx,Pulse,ON,Everlight and Freescale. Main products comprise IC,Modules,Potentiometer,IC Socket,Relay,Connector.Our parts cover such applications as commercial,industrial, and automotives areas.

We are looking forward to setting up business relationship with you and hope to provide you with the best service and solution. Let us make a better world for our industry!



Contact us

Tel: +86-755-8981 8866 Fax: +86-755-8427 6832

Email & Skype: info@chipsmall.com Web: www.chipsmall.com

Address: A1208, Overseas Decoration Building, #122 Zhenhua RD., Futian, Shenzhen, China





Product Technical Specification

AirPrime XA1100



SIERRA
WIRELESS®

41111209
Rev 1

Important Notice

Due to the nature of wireless communications, transmission and reception of data can never be guaranteed. Data may be delayed, corrupted (i.e., have errors) or be totally lost. Although significant delays or losses of data are rare when wireless devices such as the Sierra Wireless modem are used in a normal manner with a well-constructed network, the Sierra Wireless modem should not be used in situations where failure to transmit or receive data could result in damage of any kind to the user or any other party, including but not limited to personal injury, death, or loss of property. Sierra Wireless accepts no responsibility for damages of any kind resulting from delays or errors in data transmitted or received using the Sierra Wireless modem, or for failure of the Sierra Wireless modem to transmit or receive such data.

Safety and Hazards

Do not operate the Sierra Wireless modem in areas where blasting is in progress, where explosive atmospheres may be present, near medical equipment, near life support equipment, or any equipment which may be susceptible to any form of radio interference. In such areas, the Sierra Wireless modem **MUST BE POWERED OFF**. The Sierra Wireless modem can transmit signals that could interfere with this equipment.

Do not operate the Sierra Wireless modem in any aircraft, whether the aircraft is on the ground or in flight. In aircraft, the Sierra Wireless modem **MUST BE POWERED OFF**. When operating, the Sierra Wireless modem can transmit signals that could interfere with various onboard systems.

Note: Some airlines may permit the use of cellular phones while the aircraft is on the ground and the door is open. Sierra Wireless modems may be used at this time.

The driver or operator of any vehicle should not operate the Sierra Wireless modem while in control of a vehicle. Doing so will detract from the driver or operator's control and operation of that vehicle. In some states and provinces, operating such communications devices while in control of a vehicle is an offence.

Limitation of Liability

The information in this manual is subject to change without notice and does not represent a commitment on the part of Sierra Wireless. SIERRA WIRELESS AND ITS AFFILIATES SPECIFICALLY DISCLAIM LIABILITY FOR ANY AND ALL DIRECT, INDIRECT, SPECIAL, GENERAL, INCIDENTAL, CONSEQUENTIAL, PUNITIVE OR EXEMPLARY DAMAGES INCLUDING, BUT NOT LIMITED TO, LOSS OF PROFITS OR REVENUE OR ANTICIPATED PROFITS OR REVENUE ARISING OUT OF THE USE OR INABILITY TO USE ANY SIERRA WIRELESS PRODUCT, EVEN IF SIERRA WIRELESS AND/OR ITS AFFILIATES HAS BEEN ADVISED OF THE POSSIBILITY OF SUCH DAMAGES OR THEY ARE FORESEEABLE OR FOR CLAIMS BY ANY THIRD PARTY.

Notwithstanding the foregoing, in no event shall Sierra Wireless and/or its affiliates aggregate liability arising under or in connection with the Sierra Wireless product, regardless of the number of events, occurrences, or claims giving rise to liability, be in excess of the price paid by the purchaser for the Sierra Wireless product.

Patents

This product may contain technology developed by or for Sierra Wireless Inc. This product includes technology licensed from QUALCOMM®. This product is manufactured or sold by Sierra Wireless Inc. or its affiliates under one or more patents licensed from InterDigital Group and MMP Portfolio Licensing.

Copyright

© 2017 Sierra Wireless. All rights reserved.

Trademarks

Sierra Wireless®, AirPrime®, AirLink®, AirVantage® and the Sierra Wireless logo are registered trademarks of Sierra Wireless.

Windows® and Windows Vista® are registered trademarks of Microsoft Corporation.

Macintosh® and Mac OS X® are registered trademarks of Apple Inc., registered in the U.S. and other countries.

QUALCOMM® is a registered trademark of QUALCOMM Incorporated. Used under license.

Other trademarks are the property of their respective owners.

Contact Information

Sales information and technical support, including warranty and returns	Web: sierrawireless.com/company/contact-us/ Global toll-free number: 1-877-687-7795 6:00 am to 6:00 pm PST
Corporate and product information	Web: sierrawireless.com

Revision History

Revision number	Release date	Changes
1	June 23, 2017	Initial revision in SWI template.

>> Contents

Function Description	6
Overview	6
Potential Applications	6
Product Highlights and Features	7
System Block Diagram	8
Multi-tone Active Interference Canceller	8
1PPS	8
AGPS for faster TTFF (HOST)	9
EASY™	9
PPS sync NMEA	10
Specifications	11
Mechanical Dimensions	11
Recommended PCB Pad Layout	11
Pin Configuration	12
Pin Assignment	12
Description of I/O Pins	13
Specifications	15
Absolute Maximum Ratings	16
Operating Conditions	16
Protocols	17
NMEA Output Sentences	17
GGA—Time, Position and Related data of Navigation Fix	17
GSA—GPS DOP and Active Satellites	19
GSV— Satellites in View	20
RMC—Recommended Minimum Navigation Information	21
VTG—Course and Speed information Relating to the Ground	22
MTK NMEA Command Protocols	22

Reference Design	23
Reference Schematic Design for Using the Active Antenna	23
Packing and Handling	24
Packaging and Handling (Tape Reel)	24
Storage and Floor Life Guidelines	26
Moisture Color Coded Card & Caution Label	26
Conditions for Pre-baking	27
Drying	27
ESD Handling	28
Reflow Soldering Temperature Profile	29
SMT Reflow Soldering Temperature Profile (For Reference Only)	29
Manual Soldering	32

>> 1: Function Description

Overview

The XA1100 is a GPS module with an integrated patch antenna. It comes with an external antenna interface with automatic antenna detection. It is one of the smallest GPS Antenna modules in the world with an ultra-compact size of 12.5 x 12.5 x 6.8 mm in a QFN Package. This ultra-compact module provides a UART interface and its unique design of SMPS is capable of reducing power consumption to a great extent.

The XA1100 is based on Chipset MT3337(E). It supports up to 210 PRN channels with 66 search channels and 22 simultaneous tracking channels. With support of QZSS and AGPS, The XA1100 can provide even more accurate positioning. Its *Tone Active Interference Canceller* is capable of removing 12 active noise sources and such feature enables more flexibility in system design.

The XA1100 is integrated along with power managements and many advanced features, including EASY™, EPO™, PPS sync NMEA, and logger. It is ideally suitable for power-sensitive devices especially for portable applications.

Potential Applications

- Handheld Devices
- M2M applications
- Asset management
- Surveillance systems
- Wearable products



Figure 1-1: XA1110

Product Highlights and Features

- 22 tracking/ 66 acquisition-channel GPS receiver
- Supports QZSS
- Sensitivity: -165dBm
- Update Rate: up to 10Hz
- 12 multi-tone active interference canceller
- High accuracy 1-PPS timing (± 20 ns RMS) and the pulse width is 100ms
- AGPS Support for Fast TTFF (Host Aiding EPO™)
- EASY™: Self-Generated Orbit Prediction for instant positioning fix
- PPS sync NMEA²
- Consumption current (@3.3V):
- Acquisition: 20mA / 21mA / 22mA (min / typical / max)
- Tracking: 19mA / 20mA / 25mA (min / typical / max)
- RoHS compliant

System Block Diagram

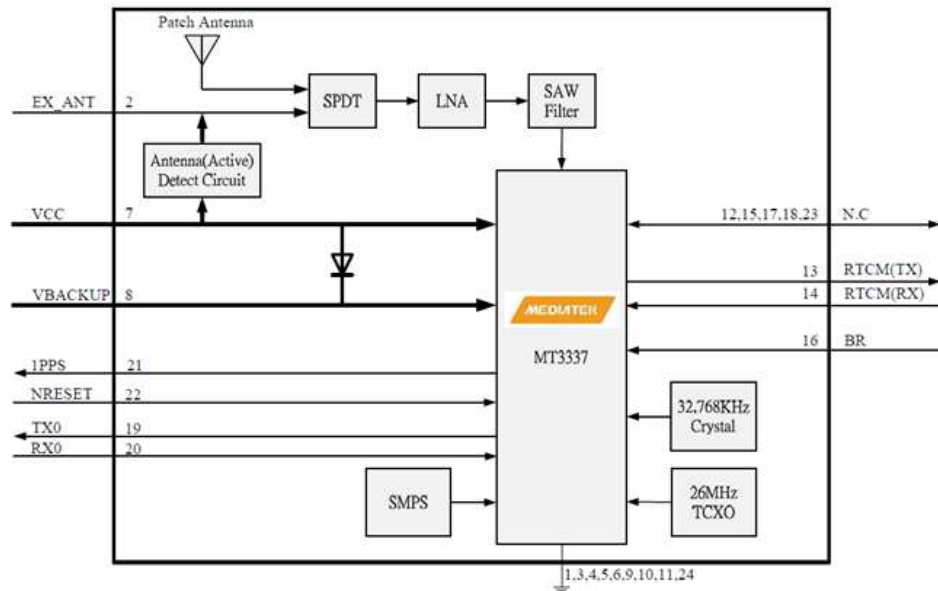

Figure 1-2: System Block Diagram

Multi-tone Active Interference Canceller

Navigation systems often integrate with variant applications that are not limited to Wi-Fi, GSM/GPRS, 3G/4G, Bluetooth. Such systems often generate RF harmonics which would influence the GPS reception and performance.

The embedded Multi-tone Active Interference Canceller (MTAIC) can reject unwanted RF harmonics of the nearby on-board active components. MTAIC improves the capacity of GPS reception, eliminating the need for hardware integration engineering to make hardware changes. The XA1100 cancels up to 12 independent channels continuous interference wave.

1PPS

The XA1100 generates a-pulse-per-second signal (1 PPS). It is an electrical signal which precisely indicates the start of a second with the accuracy of $\pm 20\text{ns}$ RMS (Root Mean Square). The PPS signal is provided through a designated output pin for many external applications. The pulse is not only limited to being active every second but is also allowed to set up the required duration, frequency, and active high/low through a user-defined PMTK command setting.

AGPS for faster TTFF (HOST)

The AGPS (HOST EPO) provides predicated EPO (Extended Prediction Orbit) data to speed up TTFF (Time To First Fix). Users can download EPO data to the GPS engine from an FTP server via the Internet or through a wireless network. The GPS engine of the module will adopt EPO data to assist with position calculation when navigation information from satellites is insufficient due to a weak signal.

EASY™

EASY™ (Embedded Assist System) is for quick positioning when information received from the satellites is insufficient. With EASY™ technology, the GPS engine is able to calculate and predict a single ephemeris automatically up to three days when the power is on. It then saves the predicted information into memory so the GPS engine can use this information for positioning later if information received from the satellites is insufficient. This function is useful for TTFF improvement to allow positioning even under weak signal conditions (e.g. in dense urban areas). Backup power (VBACKUP) is required for this feature.

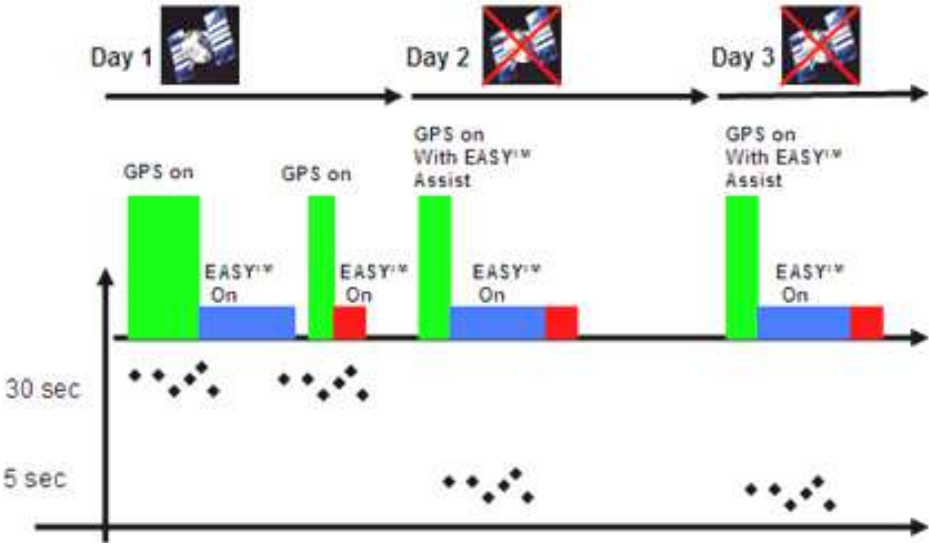

Figure 1-3: Operation of EASY™

Figure 1-3 shows that when the GPS device obtains information from GPS satellites, the GPS engine will start to pre-calculate automatically in order to predict orbits for three extended days.

PPS sync NMEA

Pulse-Per-Second (PPS) VS. NMEA can be used in the time service. The latency range of the beginning of UART Tx is between 170ms~180 ms at the MT3337(E) platform and behind the rising edge of PPS.

The PPS sync NMEA only supports 1Hz NMEA output and baud rate at 115200~14400 bps. For baud rates at 9600 bps and 4800 bps, only the RMC NMEA sentence is supported. If the NMEA sentence outputs are supported even at the low baud rate, per-second transmission may exceed the threshold of one second.

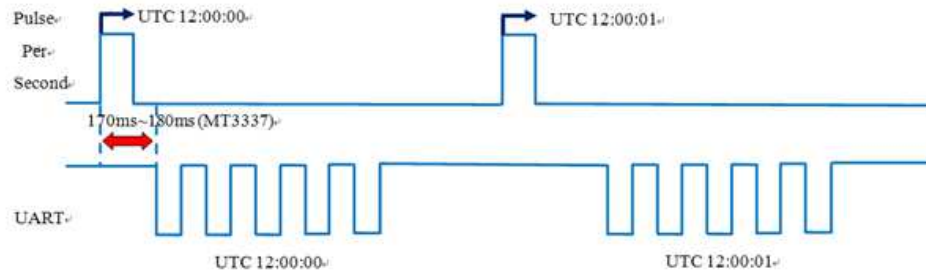

Figure 1-4: PPS sync NMEA

2: Specifications

Mechanical Dimensions

Dimension: (Unit: mm, Tolerance: +/- 0.2mm)

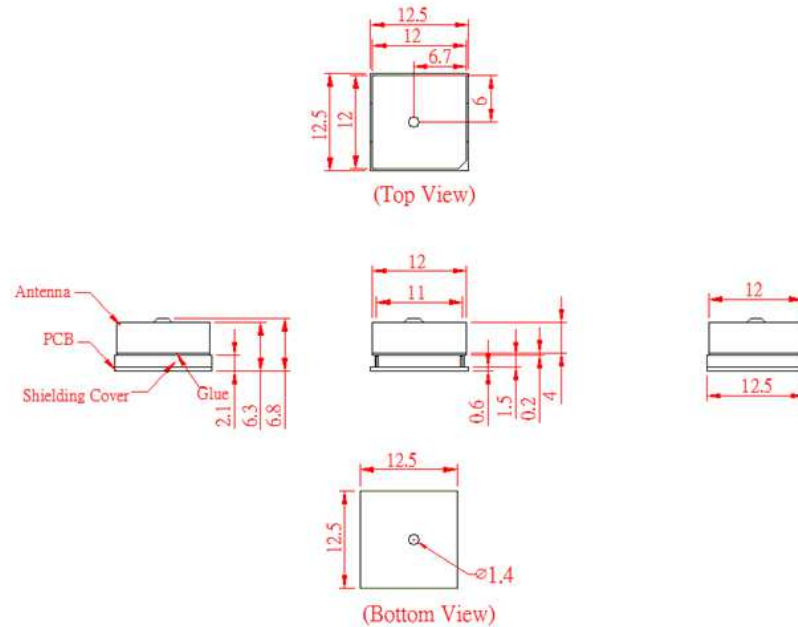

Figure 2-1: Mechanical Dimensions

Recommended PCB Pad Layout

(Unit: mm, Tolerance: 0.1mm)

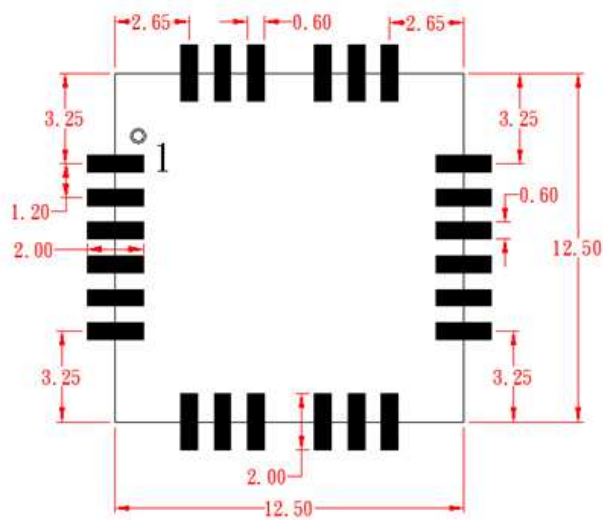

Figure 2-2: PCB Layout

Pin Configuration

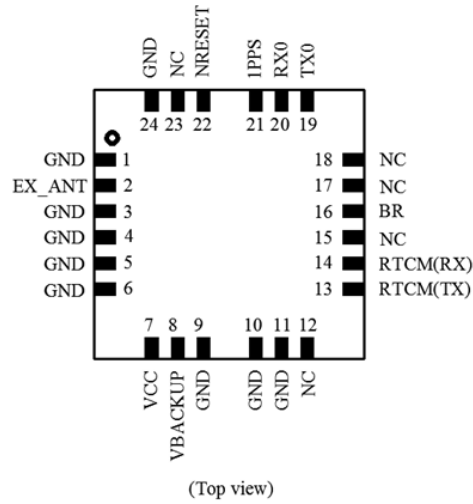

Figure 2-3: Pin Configuration

Pin Assignment

Table 2-1: Pin Assignment

Pin	Name	I/O	Description and Note
1	GND	P	Ground
2	EX_ANT	I PO	External active antenna RF input DC power from VCC and provide for external active antenna
3	GND	P	Ground
4	GND	P	Ground
5	GND	P	Ground
6	GND	P	Ground
7	VCC	PI	Main DC power input
8	VBACKUP	PI	Backup power input for RTC and navigation data keep
9	GND	P	Ground
10	GND	P	Ground
11	GND	P	Ground
12	NC	--	None Connect
13	RTCM(TX)	O	Serial Data Input (TTL) for RTCM data ACK (Acknowledge Character)
14	RTCM(RX)	I	Serial Data Input (TTL) for RTCM data streaming
15	NC	--	None Connect

Table 2-1: Pin Assignment

Pin	Name	I/O	Description and Note
16	BR	I	Baud Rate selection need to matchup BR
17	NC	--	None Connect
18	NC	--	None Connect
19	TX0	O	Serial Data Output for NMEA output (TTL)
20	RX0	I	Serial Data Input for Firmware update (TTL)
21	1PPS	O	1PPS Time Mark Output 2.8V CMOS Level (PPS setting can be configure by PMTK command) ^a
22	NRESET	I	Reset Input, Low Active
23	NC	--	None Connect
24	GND	P	Ground

a. Please refer to PMTK Command 285.

Description of I/O Pins

- **Pin1:** GND (Ground)
- **Pin2:** EX_ANT
 - When a 4mA or higher current is detected, the detect circuit will acknowledge the external antenna as being present and will use external the antenna for reception. In the event of a short circuit occurring at the external antenna, the module will limit the drawn current to a safe level. DC power from VCC and will be provided for thte external active antenna (Recommended voltage: 3.3V).
- **Pin3:** GND (Ground)
- **Pin4:** GND (Ground)
- **Pin5:** GND (Ground)
- **Pin6:** GND (Ground)
- **Pin7:** VCC
 - Main DC power supply (3.0V to 4.3V; typical: 3.3V). The ripple must be controlled under 50mVpp.
- **Pin8:** VBACKUP
 - This connects to the backup power of the GPS module. A power source (such as a battery) connected to this pin will help the GPS chipset in keeping its internal RTC running when the main power source is turned off. The voltage ranges from 2.0V~4.3V (typical: 3.0V).
 - If VBACKUP power is not reserved, the GPS module will perform a lengthy cold start each time whenever it is powered on, as previous satellite information is not retained and needs to be re-transmitted.
 - If not used, keeps this pin floating.
- **Pin9:** GND (Ground).
- **Pin10:** GND (Ground).
- **Pin11:** GND (Ground).
- **Pin12:** NC (None Connect).

- **Pin13:** RTCM (TX). Can ack for the RTCM message by pin connecting. If not used, keep it floating.
- **Pin14:** RTCM (RX). Can ack for the RTCM function by pin connecting. If not used, keep it floating.
- **Pin15:** NC (None Connect)
- **Pin16:** BR (Baud Rate selection is configurable through BR with combination a grounded 10K ohm resistor).

Table 2-2: Baud Rate

Baud Rate	BR (Pin16)
9600	No Connect
115200	10K Ohm

- **Pin17:** NC (None Connect).
- **Pin18:** NC (None Connect).
- **Pin19:** TX0 (UART 0 transmitter; outputs GPS information for the application).
- **Pin20:** RX0 (UART 0 receiver; to receive commands from the system).
- **Pin21:** 1PPS
 - This pin provides one pulse-per-second signal output.
 - If not used, keep this pin floating.
- **Pin22:** NRESET
 - Active on Low will allow the module to reset.
 - If not used, keep floating.

Table 2-3: NRESET

NRESET Level	Min(V)	Typ(V)	Max(V)
Low	0	0	1.5
High	2	3.8	3.3

- **Pin23:** NC (None Connect).
- **Pin24:** GND (Ground).

Specifications

Table 2-4: Specification Data

Description	
GPS Solution	MTK MT3337(E)
Frequency	GPS L1, 1575.42MHz
Sensitivity	Acquisition: -148dBm, cold start Reacquisition: -163dBm, Hot start Tracking: -165dBm
SV Number	#1~32
TTF (GPS, No. of SVs>4, C/N>40dB, PDop<1.5)	Hot start: 1 second typical Warm start: 24 seconds typical Cold start: 28 seconds typical, 60 seconds Max
Position Accuracy	3m (50% CEP)
Velocity Accuracy	0.1m/s
Timing Accuracy (1PPS Output)	±20ns RMS within 100ms in one pulse
Altitude	10,000m maximum (Normal mode: Car/ Pedestrian/ Aviation) 80,000m maximum (Balloon mode)
Velocity	Maximum 515m/s (1000 knots) ^a
Acceleration	Maximum 4G
Update Rate	1Hz (default), maximum 10Hz
Baud Rate	9600 bps (default), 115200 bps
Power Supply	VCC: 3V to 4.3V; VBACKUP: 2.0V to 4.3V
Current Consumption @ 3.3V,1Hz Update Rate	Acquisition : 20mA (min) / 21mA (typical) / 22mA (max) Tracking: 19mA (min) / 20mA (typical) / 25mA (max)
Power Saving (Periodic)	Standby mode: 1.6mA (TYP) ^b
NRESET Current @ 3.3V	9mA (TYP)
Working Temperature	-40 °C to +85 °C
Dimension	12.5 x 12.5 x 6.8 mm, SMD
Weight	4g

a. The number was simulated from lab test

b. Please refer to PMTK Command 161

Absolute Maximum Ratings

The maximum power supply voltage is 4.3 VDC.

Table 2-5: Maximum Ranges

	Symbol	Min.	Typ.	Max.	Unit
Power Supply Voltage	VCC	3.0	3.3	4.3	V
Backup Battery Voltage	VBACKUP	2.0	3.0	4.3	V

Operating Conditions

Table 2-6: Operating Conditions

	Condition	Min.	Typ.	Max.	Unit
Operation Supply Ripple Voltage	-	-	-	50	mVpp
RX0 TTL H Level	-	2.0	-	3.3	V
RX0 TTL L Level	-	0	-	0.8	V
TX0 TTL H Level	-	2.4	-	2.8	V
TX0 TTL L Level	-	0	-	0.4	V

3: Protocols

NMEA Output Sentences

Table 3-1 lists all NMEA output sentences specifically developed and defined by MTK for MTK's products.

Table 3-1: Position Fix Indicator

Option	Description
GGA	Time, position and fix type data.
GSA	GPS receiver operating mode, active satellites used in the position solution and DOP values.
GSV	The number of GPS satellites in view, satellite ID numbers, elevation, azimuth, and SNR values.
RMC	Time, date, position, course and speed data. The recommended minimum navigation information.
VTG	Course and speed information relative to the ground.

GGA—Time, Position and Related data of Navigation Fix

Table 3-2 explains the sentence below:

```
$GPGGA,064951.000,2307.1256,N,12016.4438,E,1,8,0.95,39.9,M,17.8,M,*65
```

Table 3-2: GGA Data Format

Name	Example	Units	Description
Message ID	\$GPGGA		GGA protocol header
UTC Time	064951.00 0		hhmmss.sss
Latitude	2307.1256		ddmm.mmmm
N/S Indicator	N		N->North or S->South
Longitude	12016.443 8		dddmm.mmmm
E/W Indicator	E		E->East or W->West
Position Fix Indicator	1		See Table 3-3
Satellites Used	8		
HDOP	0.95		Horizontal Dilution of Precision

Table 3-2: GGA Data Format

Name	Example	Units	Description
MSL Altitude	39.9	meter	Antenna Altitude above/below mean-sea-level
Units	M	meter	Units of antenna altitude
Geoidal Separation	17.8	meter	
Units	M	meter	Units of geoids separation
Age of Diff. Corr.			Null fields when DGPS is not used
Checksum	*65		
<CR> <LF>			End of message termination

Table 3-3: Position Fix Indicator

Value	Description
0	Fix not available
1	GPS Fix
2	Differential GPS Fix

GSA—GPS DOP and Active Satellites

Table 3-4 explains the example NMEA sentence below:

```
$GPGSA,A,3,29,21,26,15,18,09,06,10,,,,,2.32,0.95,2.11*00
```

Table 3-4: GSA Data Format

Name	Example	Units	Description
Message ID	\$GPGSA		GSA protocol header
Mode 1	A		See Table 3-5
Mode 2	3		See Table 3-6
Satellite Used	29		SV on Channel 1
Satellite Used	21		SV on Channel 2
....
Satellite Used			SV on Channel 12
PDOP	2.32		Position Dilution of Precision
HDOP	0.95		Horizontal Dilution of Precision
VDOP	2.11		Vertical Dilution of Precision
Checksum	*00		
<CR> <LF>			End of message termination

Table 3-5: Mode 1

Value	Description
M	Manual—forced to operate in 2D or 3D mode
A	2D Automatic—allowing to switch to 2D/3D mode automatically

Table 3-6: Mode 2

Value	Description
1	Fix not available
2	2D (<4 SVs used)
3	3D (>=4 SVs used)

GSV— Satellites in View

Table 3-7 explains the example NMEA sentence below:

```
$GPGSV,4,1,15,29,36,029,42,21,46,314,43,26,44,020,43,15,21,321,39*7D
```

```
$GPGSV,4,2,15,18,26,314,40,09,57,170,44,06,20,229,37,10,26,084,37*77
```

```
$GPGSV,4,3,15,07,, , ,26*73
```

Table 3-7: GSV Data Format

Name	Example	Units	Description
Message ID	\$GPGSV		GSV protocol header
Number of Messages	4		(Depending on the number of satellites tracked, multiple messages of GSV data may be required) ^a
Message Number	1		
Satellites in View	15		
Satellite ID	29		Channel 1 (Range 1 to 32)
Elevation	36	degrees	Channel 1 (Maximum 90)
Azimuth	029	degrees	Channel 1 (True, Range 0 to 359)
SNR (C/No)	42	dB-Hz	Range 0 to 99, (null when not tracking)
....
Satellite ID	15		Channel 4 (Range 1 to 32)
Elevation	21	degrees	Channel 4 (Maximum 90)
Azimuth	321	degrees	Channel 4 (True, Range 0 to 359)
SNR (C/No)	39	dB-Hz	Range 0 to 99, (null when not tracking)
Checksum	*7D		
<CR> <LF>			End of message termination

a. One GSV sentence can only receive up to 4 SVs

RMC—Recommended Minimum Navigation Information

Table 3-8 explains the example sentence below:

```
$GPRMC,064951.000,A,2307.1256,N,12016.4438,E,0.03,165.48,260406,3.05,W,A*2C
```

Table 3-8: RMC Data Format

Name	Example	Units	Description
Message ID	\$GPRMC		RMC protocol header
UTC Time	064951.000		hhmmss.sss
Status	A		A: data valid V: data not valid
Latitude	2307.1256		ddmm.mmmm
N/S Indicator	N		N: North S: South
Longitude	12016.4438		dddmm.mmmm
E/W Indicator	E		E: East W: West
Speed over Ground	0.03	knots	
Course over Ground	165.48	degrees	True
Date	260406		ddmmyy
Magnetic Variation			
Mode	A		A: Autonomous mode D: Differential mode E: Estimated mode
Checksum	*2C		
<CR> <LF>			End of message termination

VTG—Course and Speed information Relating to the Ground

Table 3-9 explains the example sentence below:

```
$GPVTG,165.48,T,,M,0.03,N,0.06,K,A*37
```

Table 3-9: VTG Data Format

Name	Example	Units	Description
Message ID	\$GPVTG		VTG protocol header
Course	165.48	degrees	Measured heading
Reference	T		TRUE
Course		degrees	Measured heading
Reference	M		Magnetic Variation (By Customization)
Speed	0.03	Knots/hr	Measured horizontal speed
Units	N		Knots
Speed	0.06	km/hr	Measured horizontal speed
Units	K		Kilometers per hour
Mode	A		A: Autonomous mode D: Differential mode E: Estimated mode
Checksum	*37		
<CR> <LF>			End of message termination

MTK NMEA Command Protocols

Packet Type: 103 PMTK_CMD_COLD_START

Packet Meaning: Cold Start --- Discarding the data of Time, Position, Almanacs and Ephemeris at re-start.

Example: \$PMTK103*30<CR><LF>

Note: Please refer to the PMTK command document for details.

4: Reference Design

This section introduces the reference schematic design for best performance. Additional tips and cautions on design are well documented in the related Application Note that is available upon request.

Reference Schematic Design for Using the Active Antenna

Connect the external antenna to RF_IN (Pin2):

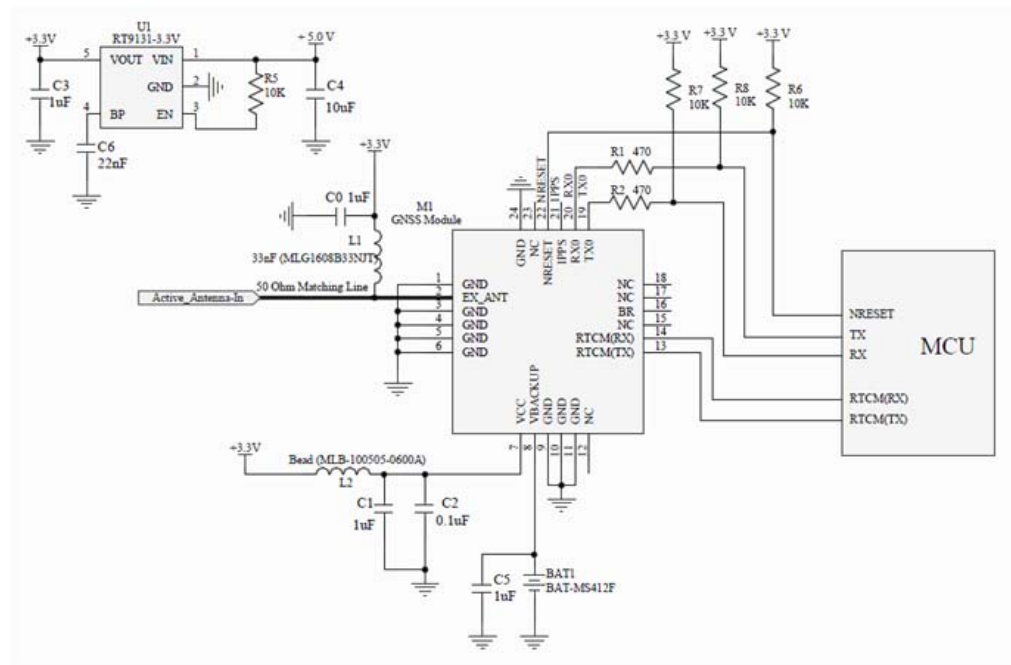

Figure 4-1: Active Antenna Application

Notes:

1. Chock coil L1 is used in electrical circuits to pass direct current and attenuate alternating current.
2. Ferrite bead L2 is added for power noise reduction. Use one with equivalent impedance (600Ω at 100MHz; IDC 200mA).
3. Place C0, C1, C2 and C5 bypass-capacitors as close as possible to the module.
4. Damping resistors R1 and R2 can be modified based on system application for EMI.

5: Packing and Handling

The XA1100, like any other SMD devices, is sensitive to moisture, electrostatic discharge and temperature. By following the standards of storage and handling outlined in this document for GNSS modules, the chances of them being damaged during production setup can be reduced. This section will walk you through the basics on how Sierra Wireless packages the modules, to ensure that the modules arrive at their destination without any damages or deterioration for performance quality. Cautionary steps prior to the surface mount process are also included in the cautionary notes.

Important: Please read the following sections carefully to avoid possible damage.

Important: GPS receiver modules are highly electrostatic-sensitive devices. Without ESD protections or without proper handling may lead to permanent damage to the modules.

Packaging and Handling (Tape Reel)

350pcs/Reel

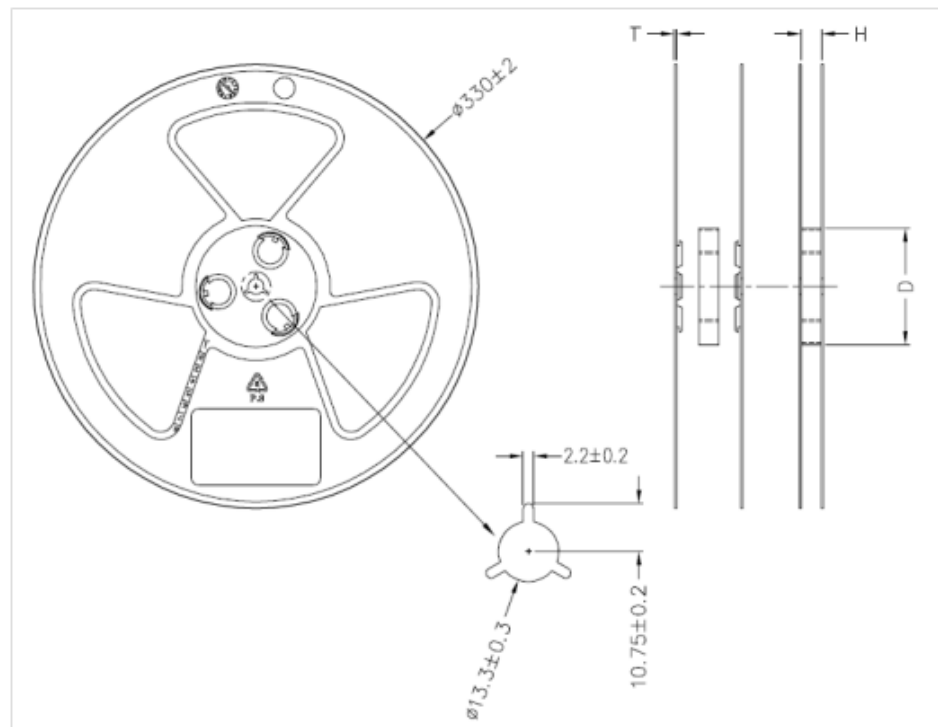

Figure 5-1: Reel Dimensions

Specs:

H: 24.5 ± 1.5 ,

T: 2.2 ± 0.2 ,

D: 99 ± 1.5

Note: 13" Reel;

Material: P.S

Unit: (mm)

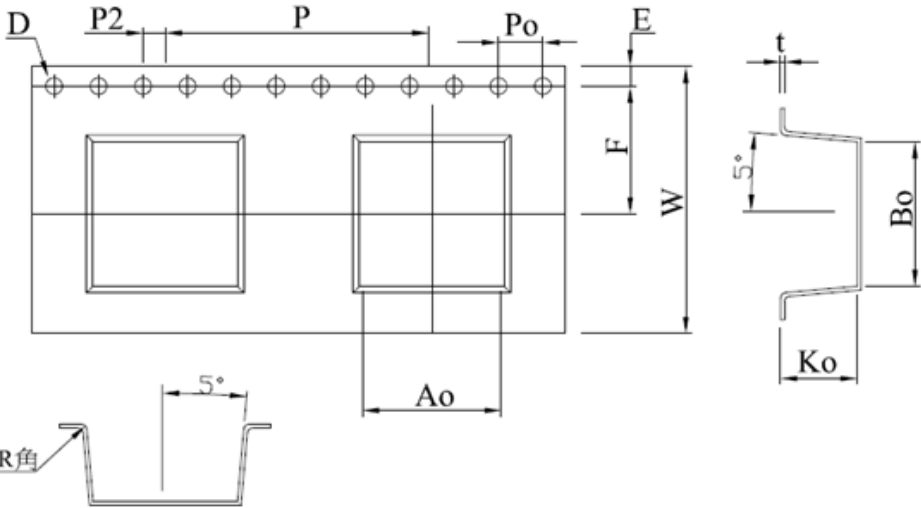

Figure 5-2: Tape Dimensions

Specs:

Ao 13.0 ± 0.10

Bo 13.0 ± 0.10

Ko 6.90 ± 0.10

Unit: (mm)