



Chipsmall Limited consists of a professional team with an average of over 10 year of expertise in the distribution of electronic components. Based in Hongkong, we have already established firm and mutual-benefit business relationships with customers from,Europe,America and south Asia,supplying obsolete and hard-to-find components to meet their specific needs.

With the principle of “Quality Parts,Customers Priority,Honest Operation,and Considerate Service”,our business mainly focus on the distribution of electronic components. Line cards we deal with include Microchip,ALPS,ROHM,Xilinx,Pulse,ON,Everlight and Freescale. Main products comprise IC,Modules,Potentiometer,IC Socket,Relay,Connector.Our parts cover such applications as commercial,industrial, and automotives areas.

We are looking forward to setting up business relationship with you and hope to provide you with the best service and solution. Let us make a better world for our industry!



Contact us

Tel: +86-755-8981 8866 Fax: +86-755-8427 6832

Email & Skype: info@chipsmall.com Web: www.chipsmall.com

Address: A1208, Overseas Decoration Building, #122 Zhenhua RD., Futian, Shenzhen, China



1A Low Dropout Positive Voltage Regulator

■ GENERAL DESCRIPTION

The XB1117 series is 1A Bi-polar transistor LDO voltage regulator. Output voltage of the XB1117P series is fixed to 1.8V, 2.5V, 3.3V, and 5.0V. The XB1117K series output voltage is adjustable by the external resistors. Please refer to the absolute maximum ratings for the difference between the rated input voltage of the XB1117P50 ($V_{OUT}=5.0V$) and XB1117P18, 25, 31, K12B. With the dropout voltage 1.2V (TYP.), output current can be generated up to 1A. The built-in overcurrent circuit and thermal protection circuit start to operate when either one of output current reaches the current limit level or junction temperature reaches the temperature limit. The XB1117 series provide stable line and load regulation by using an input capacitor and an output capacitor ($10\mu F$, tantalum). Package is available in SOT-223.

■ APPLICATIONS

- Highly efficient linear regulators
- 5V ~ 3.3V DC / DC converter
- Battery charger
- Local power supply inside equipment
- Battery powered equipment

■ FEATURES

Maximum Output Current	: 1A
Output Voltages	: 1.8V, 2.5V, 3.3V, 5.0V, ADJ
Output Voltage Accuracy	: $\pm 1\%$
Low Dropout Voltage	: 1.2V @ $I_{OUT}=1A$
Line Regulation (TYP.)	: 0.04% (ADJ)
Load Regulation (TYP.)	: 0.1% (ADJ)
Adjust Pin Current	: Less than $120\mu A$ (ADJ)
Protection Circuit	: Over-current protection Thermal protection
Package	: SOT-223
Environmentally Friendly	: EU RoHS Compliant, Pb Free

■ TYPICAL APPLICATION CIRCUIT

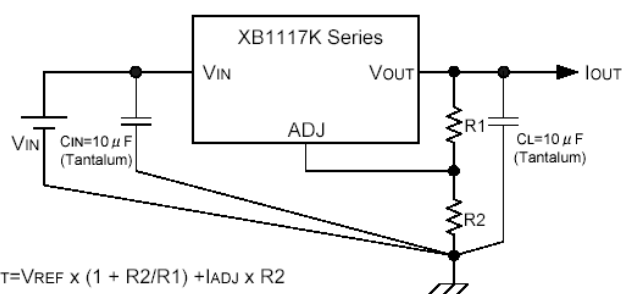
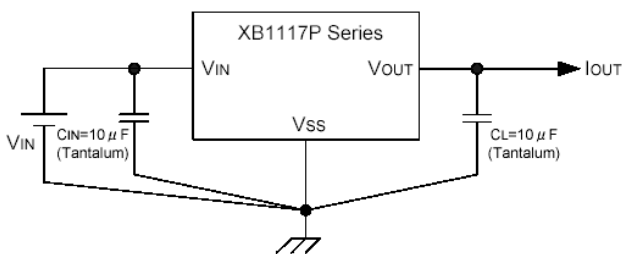

$$V_{OUT} = V_{REF} \times (1 + R2/R1) + I_{ADJ} \times R2$$

■ TYPICAL PERFORMANCE CHARACTERISTICS

- Reference Voltage vs. Ambient Temperature

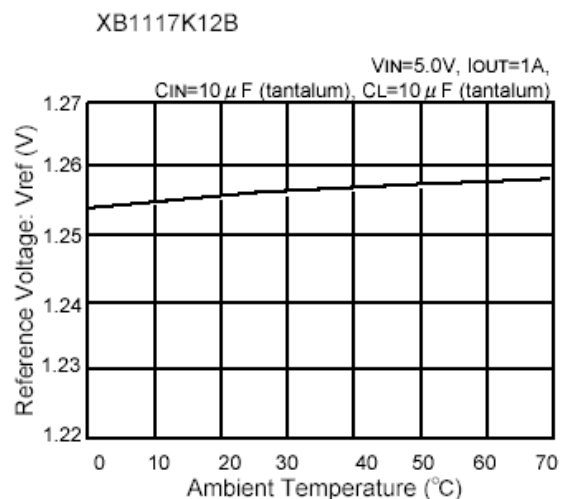

■ PIN CONFIGURATION

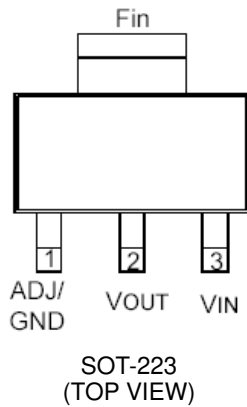

■ PIN ASSIGNMENT

PIN NUMBER	PIN NAME	FUNCTIONS
1	ADJ/GND	ADJ/Ground
2	VOUT	Output
3	VIN	Input

* The electrical potential of the package fin is the same as the VOUT pin.

■ PRODUCT CLASSIFICATION

● Ordering Information

XB1117①②③④⑤⑥-⑦

DESIGNATOR	ITEM	SYMBOL	DESCRIPTION
①	Type of Regulators	P	Fixed VOUT type
		K	Adjustable VOUT type
②③④	Output Voltage & Accuracy	181	Fixed VOUT 1.80V (±1%)
		251	Fixed VOUT 2.50V (±1%)
		331	Fixed VOUT 3.30V (±1%)
		501	Fixed VOUT 5.00V (±1%)
		12B	Adjustable VOUT 1.25V (±1%)
⑤⑥-⑦ ^(*)	Package (Order Unit)	FR-G	SOT-223(1,000/Reel)

^(*) The "-G" suffix denotes Halogen and Antimony free as well as being fully EU RoHS compliant.

■ BLOCK DIAGRAM

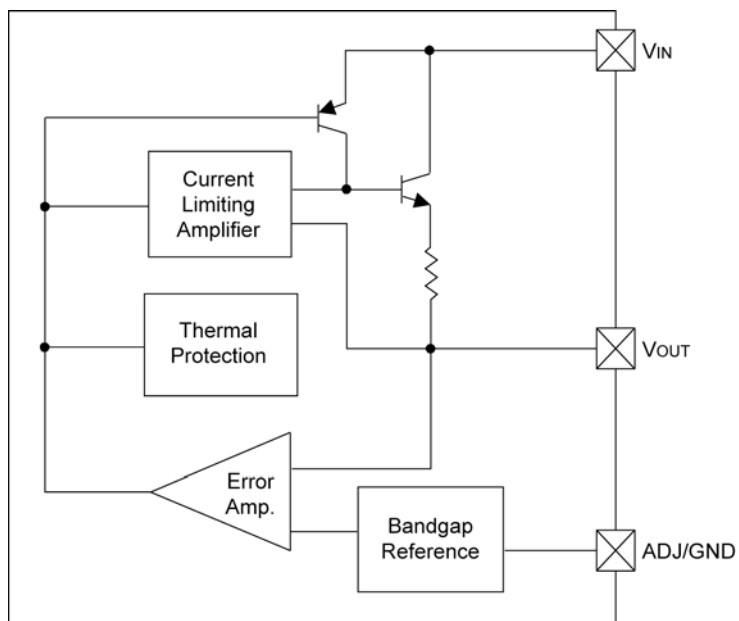

■ ABSOLUTE MAXIMUM RATINGS

XB1117P501

PARAMETER	SYMBOL	RATINGS	UNITS
Input Voltage	V _{IN}	10.0	V
Thermal Resistance (Junction to Case)	θ_{JC}	15	°C/W
Thermal Resistance (Junction to Ambient)	θ_{JA}	160	
Power Dissipation ($\Delta T=100^{\circ}\text{C}$)	P _D	625	mW
Operating Ambient Temperature	T _{opr}	0 ~ +70	°C
Operating Junction Temperature Range	T _j	0 ~ +125	
Storage Temperature Range	T _{stg}	- 65 ~ +150	
Lead Temperature	T _{lead}	260	

*Stress above the listed absolute maximum rating may cause permanent damage to the device.

** The rated values of the XB1117P18 / 25 / 30 (V_{OUT}=1.8V, 2.5V and 3.0V) and XB1117K type are different from that of the XB1117P50 (V_{OUT}=5.0V).

■ ELECTRICAL CHARACTERISTICS

XB1117P501

T_a=25°C

PARAMETER	SYMBOL	CONDITIONS	MIN.	TYP.	MAX.	UNITS
Output Voltage	V _{OUT}	V _{IN} =7.0V I _{OUT} =0A	4.950	5.000	5.050	V
		*Over Temp.	4.900	5.000	5.100	
Line Regulation	ΔV_{OUT1}	7.0V ≤ V _{IN} ≤ 9.0V I _{OUT} =0A	-	1	6	mV
Load Regulation	ΔV_{OUT2}	V _{IN} =7.0V 0A ≤ I _{OUT} ≤ 1.0A	-	5.0	15.2	
Dropout Voltage	V _{dif}	$\Delta V_{OUT} = \pm 1\%$ 0A ≤ I _{OUT} ≤ 1.0A	-	1.2	1.4	V
		*Over Temp.	-	1.3	-	
Current Limit	I _{LIM}	7.0V ≤ V _{IN} ≤ 10.0V	1.0	1.5	-	A
Supply Current	I _{SS}	V _{IN} =7.0V 0A ≤ I _{OUT} ≤ 1.0A	-	6	13	mA
Temperature Coefficient	T _C	7.0V ≤ V _{IN} ≤ 10.0V 0A ≤ I _{OUT} ≤ 1.0A	-	50	-	ppm/°C
Temperature Stability	T _S	V _{IN} =7.0V I _{OUT} =100mA	-	0.5	-	%

*Over Temp. = Over Temperature (0 ~ +70°C)

■ ABSOLUTE MAXIMUM RATINGS

XB1117P181, P251, P331, K12B

PARAMETER	SYMBOL	RATINGS	UNITS
Input Voltage	V _{IN}	7.0	V
Thermal Resistance (Junction to Case)	θ_{JC}	15	°C/W
Thermal Resistance (Junction to Ambient)	θ_{JA}	160	
Power Dissipation ($\Delta T=100^{\circ}\text{C}$)	P _D	625	mW
Operating Ambient Temperature	T _{OPR}	0 ~ 70	°C
Operating Temperature Range	T _J	0 ~ 125	
Storage Temperature Range	T _{STG}	-65 ~ 150	
Lead Temperature	T _{LEAD}	260	

*Stress above the listed absolute maximum rating may cause permanent damage to the device.

■ ELECTRICAL CHARACTERISTICS

XB1117P181

 T_J=25°C

PARAMETER	SYMBOL	CONDITIONS	MIN.	TYP.	MAX.	UNITS
Output Voltage	V _{OUT}	V _{IN} =5.0V I _{OUT} =0A *Over Temp.	1.782	1.800	1.818	V
Line Regulation	ΔV_{OUT1}	4.75V ≤ V _{IN} ≤ 7.0V I _{OUT} = 0A	-	1.0	5.5	mV
Load Regulation	ΔV_{OUT2}	V _{IN} =5.0V 0A ≤ I _{OUT} ≤ 1.0A *Over Temp.	-	1.80 3.70	18.2 22.0	mV
Dropout Voltage	V _{dif}	$\Delta V_{OUT} = \pm 1\%$ 0A ≤ I _{OUT} ≤ 1.0A *Over Temp.	-	1.2 1.3	1.4 -	V
Current Limit	I _{LIM}	4.75V ≤ V _{IN} ≤ 7.0V *Over Temp.	1.0	1.5	-	A
Supply Current	I _{SS}	V _{IN} =5.0V 0A ≤ I _{OUT} ≤ 1.0A *Over Temp.	-	6	13	mA
Temperature Coefficient	T _C	4.75V ≤ V _{IN} ≤ 7.0V 0A ≤ I _{OUT} ≤ 1.0A	-	50	-	ppm/ °C
Temperature Stability	T _S	V _{IN} =5.0V I _{OUT} =100mA *Over Temp.	-	0.5	-	%

*Over Temp. = Over Temperature (0~+70°C)

XB1117P251

 T_J=25°C

PARAMETER	SYMBOL	CONDITIONS	STANDARD VALUE			UNITS
			MIN.	TYP.	MAX.	
Output Voltage	V _{OUT}	V _{IN} =5.0V I _{OUT} =0A *Over Temp.	2.475 2.450	2.500	2.525 2.550	V
Line Regulation	ΔV_{OUT1}	4.75V ≤ V _{IN} ≤ 7.0V I _{OUT} =0A	-	1.0	6.8	mV
Load Regulation	ΔV_{OUT2}	V _{IN} =5.0V 0A ≤ I _{OUT} ≤ 1.0A *Over Temp.	-	2.5 5.1	25.3 30.3	mV
Dropout Voltage	V _{dif}	$\Delta V_{OUT} = \pm 1\%$ 0A ≤ I _{OUT} ≤ 1.0A *Over Temp.	-	1.2 1.3	1.4 -	V
Current Limit	I _{LIM}	4.75V ≤ V _{IN} ≤ 7.0V *Over Temp.	1.0	1.5	-	A
Supply Current	I _{SS}	V _{IN} =5.0V 0A ≤ I _{OUT} ≤ 1.0A *Over Temp.	-	6	13	mA
Temperature Coefficient	T _C	4.75V ≤ V _{IN} ≤ 7.0V 0A ≤ I _{OUT} ≤ 1.0A	-	50	-	ppm/ °C
Temperature Stability	T _S	V _{IN} =5.0V I _{OUT} =100mA *Over Temp.	-	0.5	-	%

*Over Temp. = Over Temperature (0~+70°C)

ELECTRICAL CHARACTERISTICS (Continued)

XB1117P331

T_J=25°C

PARAMETER	SYMBOL	CONDITIONS	MIN.	TYP.	MAX.	UNITS	
Output Voltage	V _{OUT}	V _{IN} =5.0V I _{OUT} =0A	3.267	3.300	3.333	V	
		*Over Temp.	3.234	3.300	3.366		
Line Regulation	ΔV _{OUT1}	4.75V ≤ V _{IN} ≤ 7.0V I _{OUT} =0A	-	1.0	4.5	mV	
Load Regulation	ΔV _{OUT2}	V _{IN} =5.0V 0A ≤ I _{OUT} ≤ 1.0V	-	3.4	10.0		
Dropout Voltage	V _{dif}	ΔV _{OUT} =±1%	-	1.2	1.4	V	
		0A ≤ I _{OUT} ≤ 1.0A	*Over Temp.	-	1.3		-
Current Limit	I _{LIM}	4.75V ≤ V _{IN} ≤ 7.0V	*Over Temp.	1.0	1.5	A	
Supply Current	I _{SS}	V _{IN} =5.0V 0A ≤ I _{OUT} ≤ 1.0A	*Over Temp.	-	6	13	mA
Temperature Coefficient	T _C	4.75V ≤ V _{IN} ≤ 7.0V 0A ≤ I _{OUT} ≤ 1.0A	-	50	-	ppm/°C	
Temperature Stability	T _S	V _{IN} =5.0V I _{OUT} =100mA	*Over Temp.	-	0.5	-	%

*Over Temp. = Over Temperature (0~+70°C)

XB1117K12B

T_J=25°C

PARAMETER	SYMBOL	CONDITIONS	MIN.	TYP.	MAX.	UNITS	
Reference voltage	V _{ref}	V _{IN} =5.0V I _{OUT} =10mA	1.238	1.250	1.262	V	
		*Over Temp.	1.225	1.250	1.275		
Line Regulation	ΔV _{OUT1}	4.75V ≤ V _{IN} ≤ 7.0V I _{OUT} =0A	-	0.04	0.20	%	
Load Regulation	ΔV _{OUT2}	V _{IN} =5.0V 10mA ≤ I _{OUT} ≤ 1.0A	-	0.1	0.3	%	
		*Over Temp.	-	0.2	0.4		
Dropout Voltage	V _{dif}	ΔV _{OUT} =±1%	-	1.2	1.4	V	
		10mA ≤ I _{OUT} ≤ 1.0A	*Over Temp.	-	1.3		-
Current Limit	I _{LIM}	2.75A ≤ V _{IN} ≤ 7.0V	*Over Temp.	1.0	1.5	A	
Temperature Coefficient	T _C	2.75V ≤ V _{IN} ≤ 7.0V 10mA ≤ I _{OUT} ≤ 1.0A	-	50	-	ppm/°C	
Adjust Pin Current	I _{ADJ}	2.75V ≤ V _{IN} ≤ 7.0V 10mA ≤ I _{OUT} ≤ 1.0A	-	55	-	μA	
		*Over Temp.	-	-	120		
Adjust Pin Current Change	ΔI _{ADJ}	2.75V ≤ V _{IN} ≤ 7.0V 10mA ≤ I _{OUT} ≤ 1.0A	*Over Temp.	-	0.2	5.0	μA
Temperature Stability	T _S	V _{IN} =5.0V I _{OUT} =100mA	*Over Temp.	-	0.5	-	%
Minimum Load Current	I _{OUT}	V _{OUT} =5.0V	-	-	10	mA	

*Over Temp. = Over Temperature (0~+70°C)

■ OPERATIONAL EXPLANATION

1. Output voltage adjustment

The XB1117 series provide a stable output by comparing the output voltage to an internal reference voltage. With the adjustable XB1117K type, a 1.25V reference voltage (V_{REF}) is fixed between the V_{OUT} pin and the ADJ pin and the external resistors R1 and R2 are used to set the output voltage. The resistance values of R1 and R2 should be set so as to provide a minimum load current of 10mA. The output voltage is given by the following equation.

$$V_{OUT} = V_{REF}(1 + R2/R1) + I_{ADJ} \times R2$$

The output voltage of the XB1117P type is internally fixed to 1.8V, 2.5V, 3.3V, and 5.0V so external resistors are not necessary.

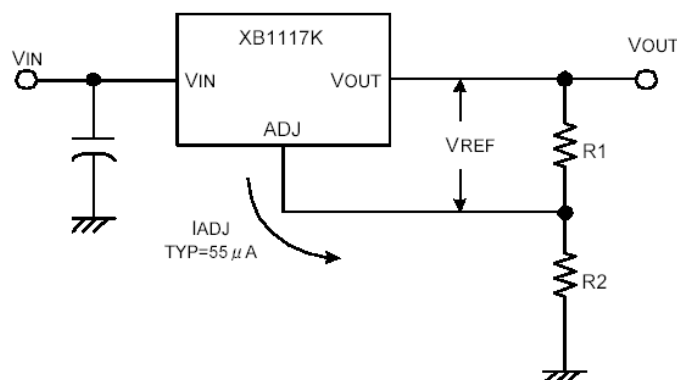

2. Stability and load regulation

The XB1117 series requires a load capacitor between the V_{OUT} pin and the GND pin to provide phase compensation thereby ensuring stability of the output voltage. Either a tantalum capacitor of more than $10 \mu F$ (TYP.) or an aluminum electrolytic capacitor of more than $50 \mu F$ (TYP.) should be connected.

(Note : The capacitor's ESR value should not exceed 0.5Ω .)

The output capacitor does not have a theoretical upper limit so increasing its value will increase stability. $C_L = 100 \mu F$ or more is typical for high current regulator design.

In order to avoid any reductions in output voltage accuracy with the XB1117K type, we recommend not to place a parasitic resistor (R_p) between the V_{OUT} pin and the divider resistor R1. The parasitic resistor (R_p) does not influence the output however if the divider resistor R1 is directly connected to the V_{OUT} pin.

With the XB1117P type, although external resistor (R1) is internally connected to the V_{OUT} pin, stability can be maintained by not wiring a parasitic resistor to the GND pin.

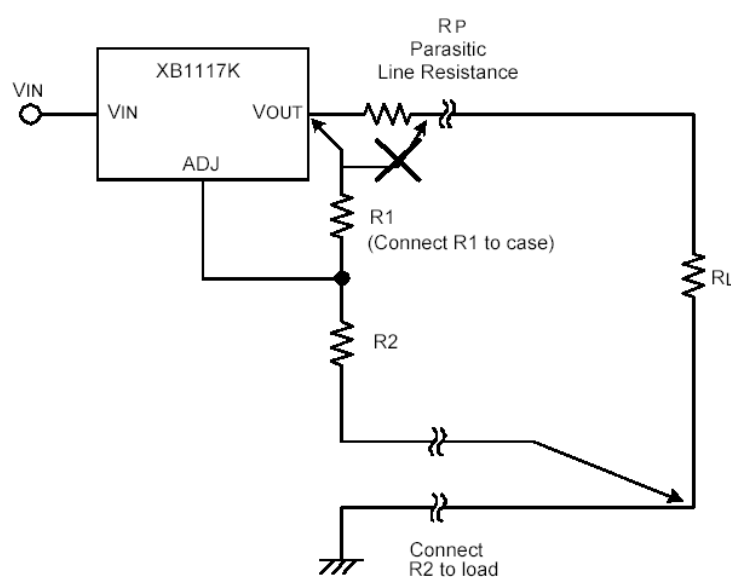

OPERATIONAL EXPLANATION (Continued)

3. Thermal protection

XB1117 series has thermal protection which limits junction temperature to 150°C. However, device functionally is only guaranteed to a maximum junction temperature of + 125°C. The power dissipation and junction temperature for the XB1117 series are given by;

$$P_D = (V_{IN} - V_{OUT}) \times I_{OUT}$$

$$T_J = T_{A+} + (P_D \times \theta_{JA})$$

NOTE : T_J must not exceed 125°C.

4. Current limit protection

XB1117 series is protected against overload conditions. Current protection is triggered at 1.5A (TYP.).

5. Thermal consideration

The XB1117 series contain thermal limiting circuitry designed to protect itself from over-temperature conditions. Even for normal load conditions, maximum junction temperature ratings must not be exceeded. As mentioned in thermal protection section, we need to consider all sources of thermal resistance between junction and ambient. It includes junction-to-case, case-to-heat-sink interface and heat sink thermal resistance itself.

Junction-to-case thermal resistance is specified from the IC junction to the bottom of the case directly below the die. Proper mounting is required to ensure the best possible thermal flow from this area of the package to the heat sink. The case of all devices in this product series is electrically connected to the output. Therefore, if the case of the device is not electrically isolated, a thermally conductive spacer is recommended.

NOTES ON USE

- For the phenomenon of temporal and transitional voltage decrease or voltage increase, the IC may be damaged or deteriorated if IC is used beyond the absolute MAX. specifications.
- Torex places an importance on improving our products and their reliability. We request that users incorporate fail-safe designs and post-aging protection treatment when using Torex products in their systems.

APPLICATION CIRCUITS

● Adjustable Output Voltage

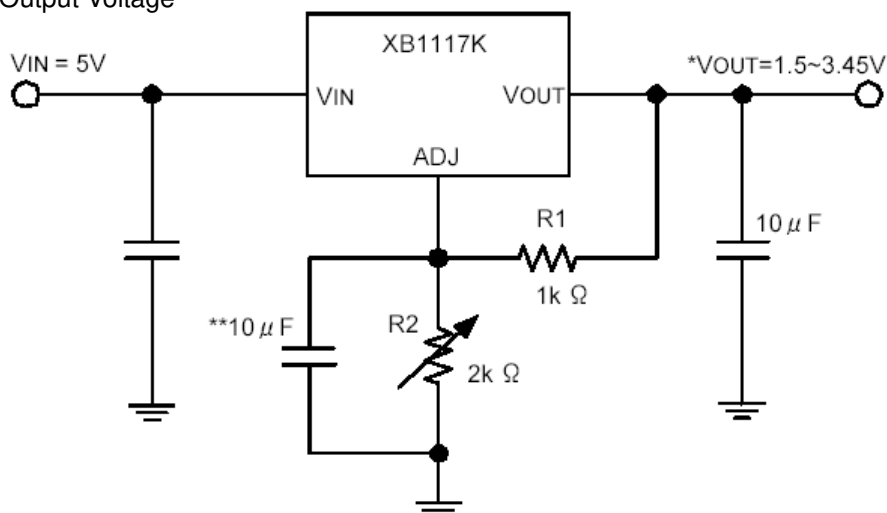

$$\text{NOTE: } *V_{OUT} = V_{REF} \left(1 + \frac{R_2}{R_1} \right) + I_{ADJ} \times R_2$$

** Optional for improved ripple rejection.

■ APPLICATION CIRCUITS (Continued)

● Regulator with reference voltage

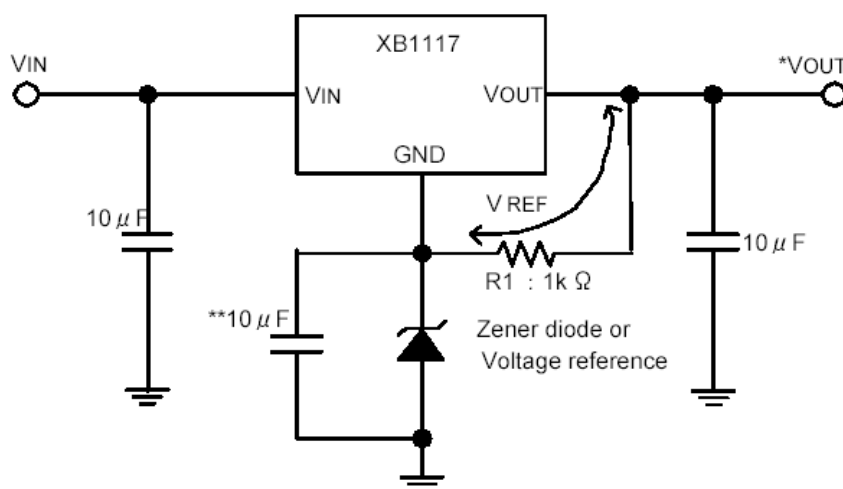

NOTE: $*V_{OUT} = V_{REF} + V_Z$ (V_Z : Zener diode)

** Optional for improved ripple rejection.

● Regulator with reverse diode protection

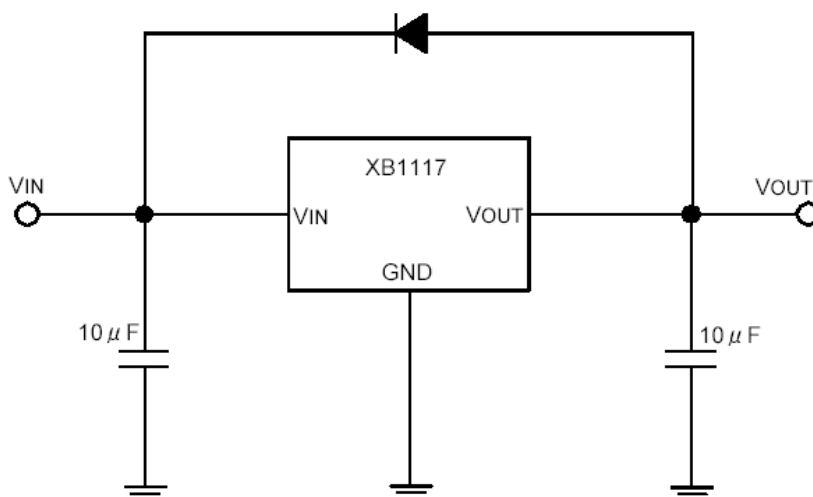

TYPICAL PERFORMANCE CHARACTERISTICS

(1) Load Regulation vs. Ambient Temperature

XB1117K12B

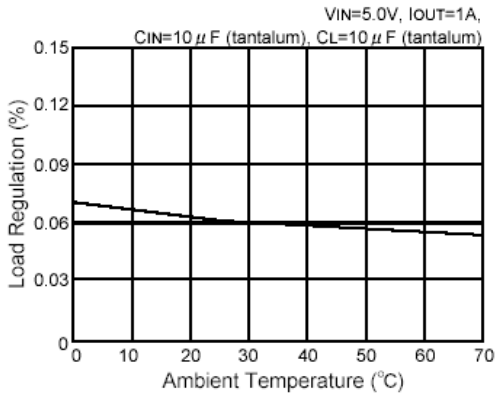

(2) Reference Voltage vs. Ambient Temperature

XB1117K12B

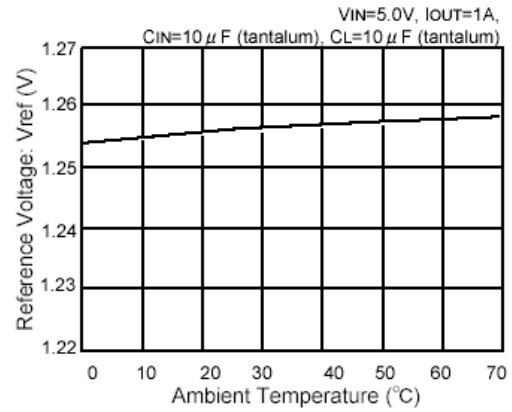

(3) Output Short Circuit Current vs. Dropout Voltage

XB1117P331

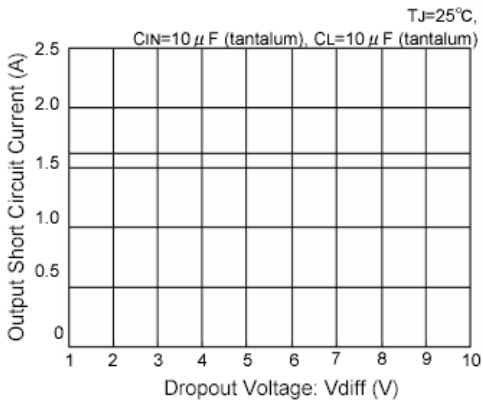

(4) Dropout Voltage vs. Output Current

XB1117P331

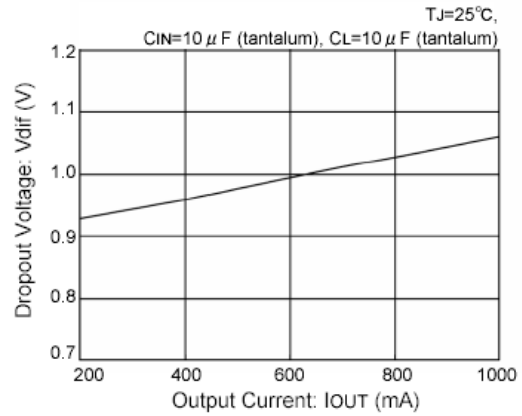

(5) Adjust Pin Current vs. Ambient Temperature

XB1117K12B

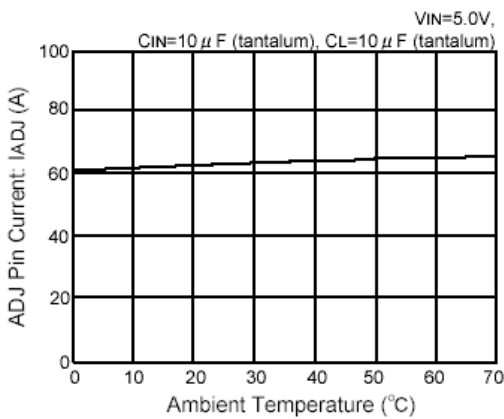

(6) Supply Current vs. Dropout Voltage

XB1117P331

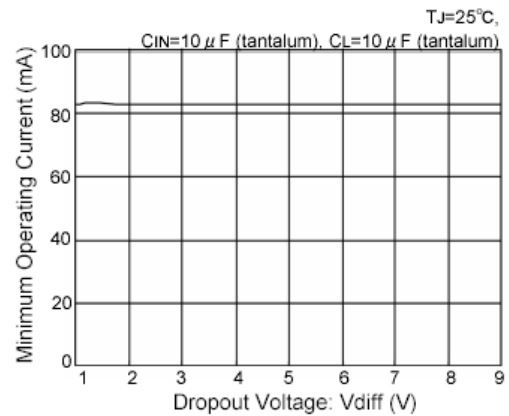

(7) Load Transient Response

XB1117P331

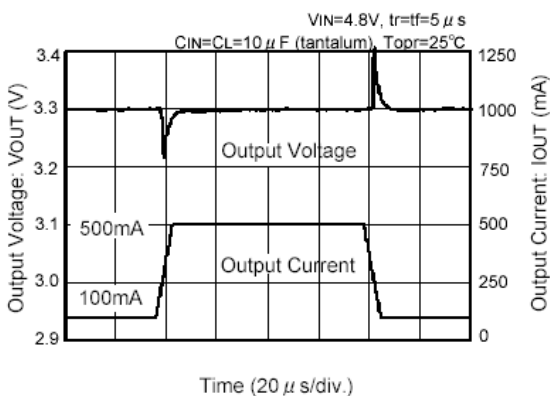

(8) Line Transient Response

XB1117P331

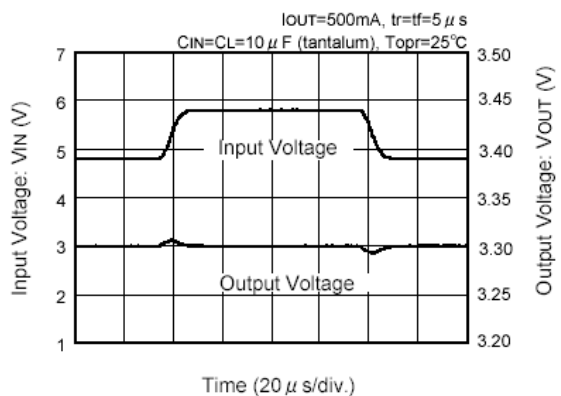

■ PACKAGING INFORMATION

● SOT-223

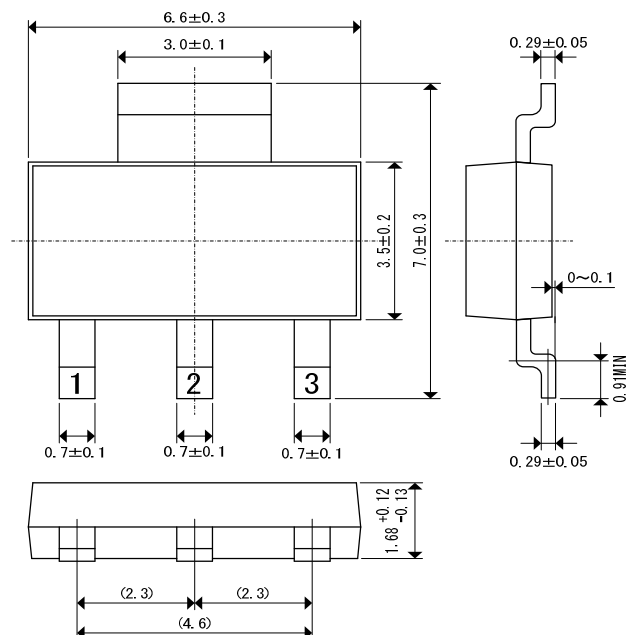

■ MARKING RULE

● SOT-223

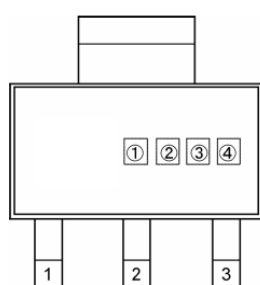

SOT-223
(TOP VIEW)

① represents product series

MARK	PRODUCT SERIES
B	XB1117xxxxFx

② represents fixed or adjustable output voltage

MARK	PRODUCT SERIES
K	XB1117KxxxxFx
P	XB1117PxxxxFx

③ represents output voltage

MARK	OUTPUT VOLTAGE (V)	PRODUCT SERIES
B	ADJ	XB1117K12BFx
K	1.8	XB1117P181Fx
T	2.5	XB1117P251Fx
2	3.3	XB1117P331Fx
M	5.0	XB1117P501Fx

④ represents production lot number

0 to 9, A to Z repeated. (G, I, J, O, Q, W are excepted.)

1. The products and product specifications contained herein are subject to change without notice to improve performance characteristics. Consult us, or our representatives before use, to confirm that the information in this datasheet is up to date.
2. We assume no responsibility for any infringement of patents, patent rights, or other rights arising from the use of any information and circuitry in this datasheet.
3. Please ensure suitable shipping controls (including fail-safe designs and aging protection) are in force for equipment employing products listed in this datasheet.
4. The products in this datasheet are not developed, designed, or approved for use with such equipment whose failure or malfunction can be reasonably expected to directly endanger the life of, or cause significant injury to, the user.
(e.g. Atomic energy; aerospace; transport; combustion and associated safety equipment thereof.)
5. Please use the products listed in this datasheet within the specified ranges.
Should you wish to use the products under conditions exceeding the specifications, please consult us or our representatives.
6. We assume no responsibility for damage or loss due to abnormal use.
7. All rights reserved. No part of this datasheet may be copied or reproduced without the prior permission of TOREX SEMICONDUCTOR LTD.

TOREX SEMICONDUCTOR LTD.