



Chipsmall Limited consists of a professional team with an average of over 10 year of expertise in the distribution of electronic components. Based in Hongkong, we have already established firm and mutual-benefit business relationships with customers from,Europe,America and south Asia,supplying obsolete and hard-to-find components to meet their specific needs.

With the principle of "Quality Parts,Customers Priority,Honest Operation,and Considerate Service",our business mainly focus on the distribution of electronic components. Line cards we deal with include Microchip,ALPS,ROHM,Xilinx,Pulse,ON,Everlight and Freescale. Main products comprise IC,Modules,Potentiometer,IC Socket,Relay,Connector.Our parts cover such applications as commercial,industrial, and automotives areas.

We are looking forward to setting up business relationship with you and hope to provide you with the best service and solution. Let us make a better world for our industry!



Contact us

Tel: +86-755-8981 8866 Fax: +86-755-8427 6832

Email & Skype: info@chipsmall.com Web: www.chipsmall.com

Address: A1208, Overseas Decoration Building, #122 Zhenhua RD., Futian, Shenzhen, China



Transient Voltage Suppressor (TVS)

GENERAL DESCRIPTION

Two elements in USP-3 package (Anode Common)
High ESD

ABSOLUTE MAXIMUM RATINGS

Ta=25°C

PARAMETER	SYMBOL	RATINGS	UNITS
Peak Pulse Power ^(*1)	Ppk	70	W
Power Dissipation	Pd	120	mW
		1000 ^(*2)	
Junction Temperature	Tj	150	°C
Storage Temperature Range	Tstg	-55~+150	°C
ESD Durability ^{(*3)(*4)}	Vpp	30	kV
Contact Discharge			

(*1): tp=8/20 μs

(*2): This is a reference data taken by using the test board.

(*3): Test Condition IEC61000-4-2 Standard

(*4): Criterion: No damage to device elements

MARKING RULE

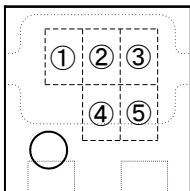

①②③ : BP1(Product Number)
④⑤ : Lot Number

PIN CONFIGURATION

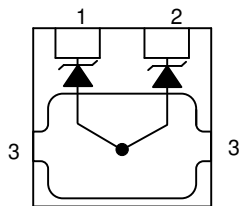

BOTTOM VIEW

1. Cathode
2. Cathode
3. Anode

APPLICATIONS

ESD protection

PACKAGING INFORMATION

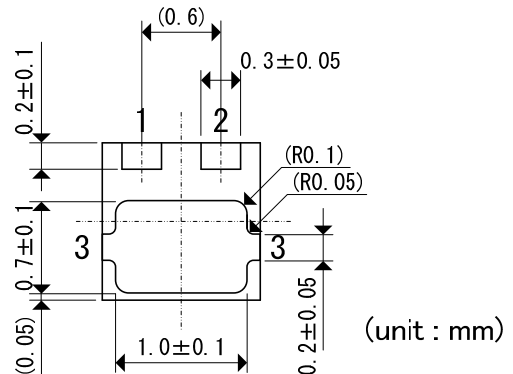
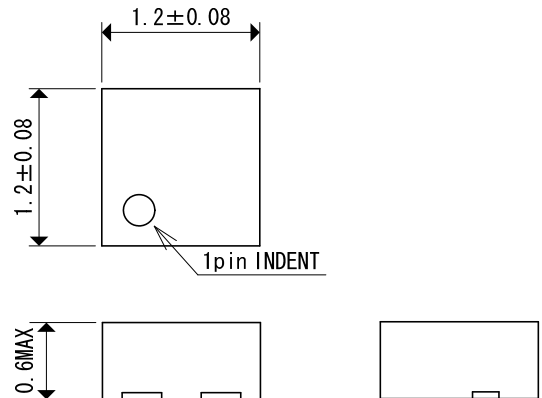

USP-3 Package

PRODUCT NAME

PRODUCT NAME	PACKAGE	ORDER UNIT
XBP06V4E2HR-G	USP-3	3,000/Reel

* The "-G" suffix indicates that the products are Halogen and Antimony free as well as being fully RoHS compliant.

ELECTRICAL CHARACTERISTICS

Ta=25°C

PARAMETER	SYMBOL	TEST CONDITION	LIMITS			UNITS
			MIN.	TYP.	MAX.	
Breakdown Voltage	V _{BR}	I _R =5mA	6.4	6.8	7.2	V
Leakage Current	I _{RM}	V _{RM} =5V	-	-	1.0	μA
Forward Voltage	V _F	I _F =10mA	-	-	1.25	V
Inter-Terminal Capacity	C _t	V _R =0V, f=1MHz	-	40	-	pF

TYPICAL PERFORMANCE CHARACTERISTICS

(1) Reverse Current vs. Breakdown Voltage

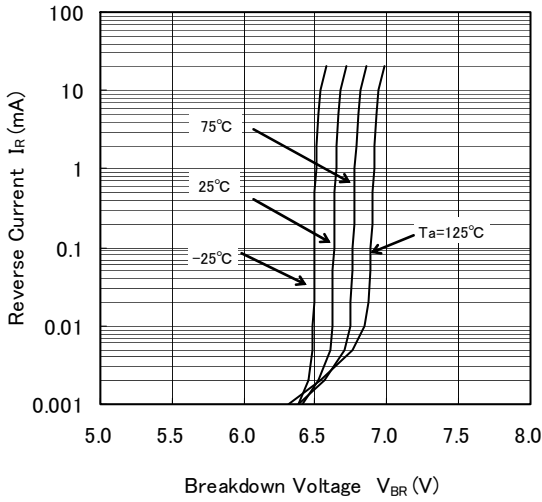

(2) Reverse Current vs. Reverse Voltage

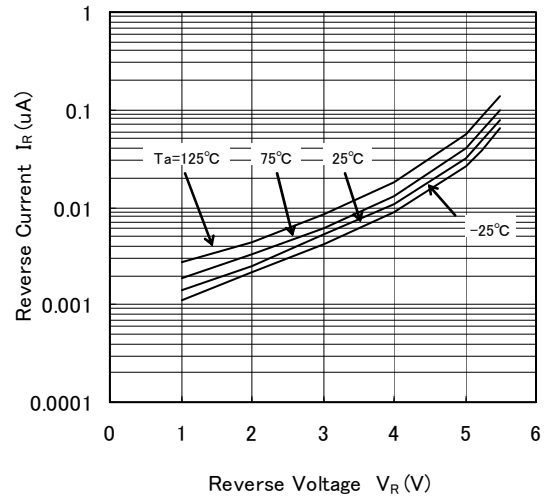

(3) Breakdown Voltage vs. Operating Temperature

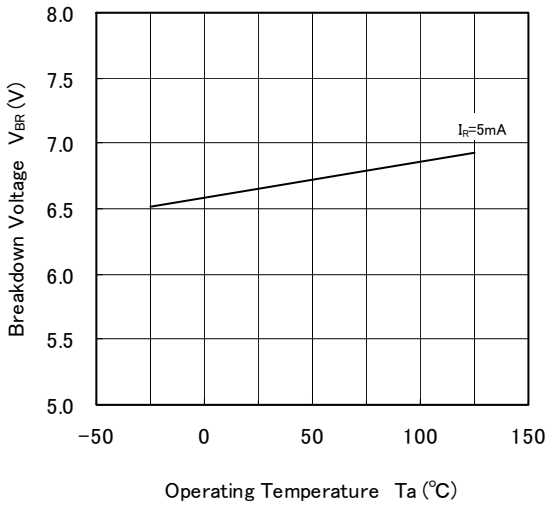

(4) Reverse Current vs. Operating Temperature

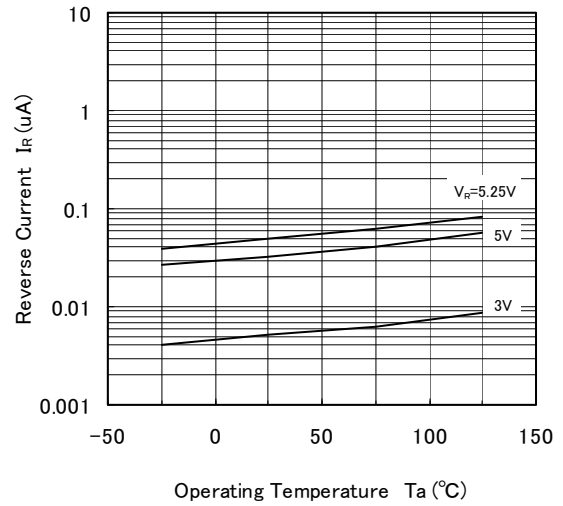

(5) Inter-Terminal Capacity vs. Reverse Voltage

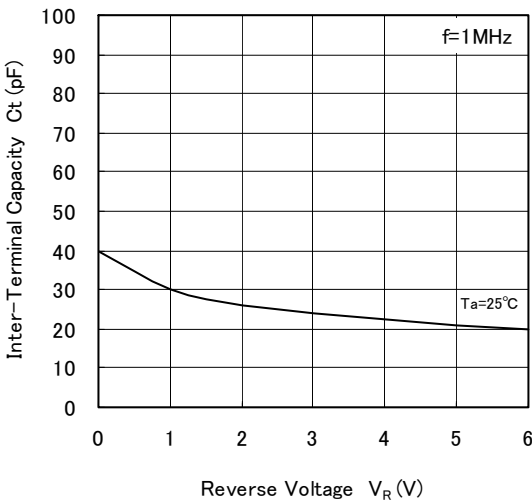

(6) Forward Current vs. Forward Voltage

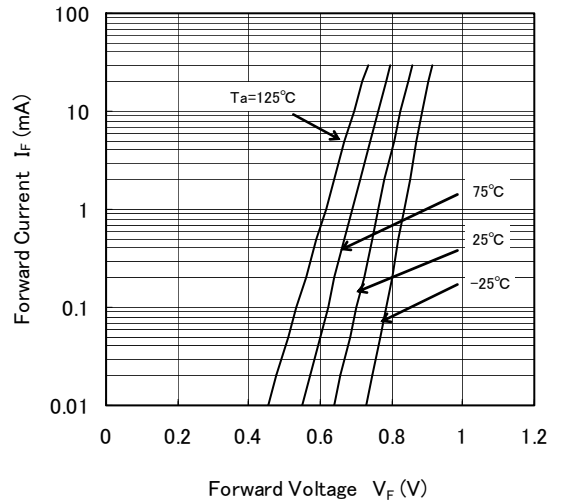

■ PACKAGING INFORMATION

● USP-3 Power Dissipation

Power dissipation data for the USP-3 is shown in this page.
The value of power dissipation varies with the mount board conditions.
Please use this data as one of reference data taken in the described condition.

1. Measurement Condition (Reference data)

- Condition: Mount on a board
- Ambient: Natural convection
- Soldering: Lead (Pb) free
- Board: Dimensions 40 x 40 mm (1600 mm² in one side)
Copper (Cu) traces occupy 50% of the board area in top and back faces.
Package heat-sink is tied to the copper traces.
- Material: Glass Epoxy (FR-4)
- Thickness: 1.6 mm
- Through-hole: 4 x 0.8 Diameter

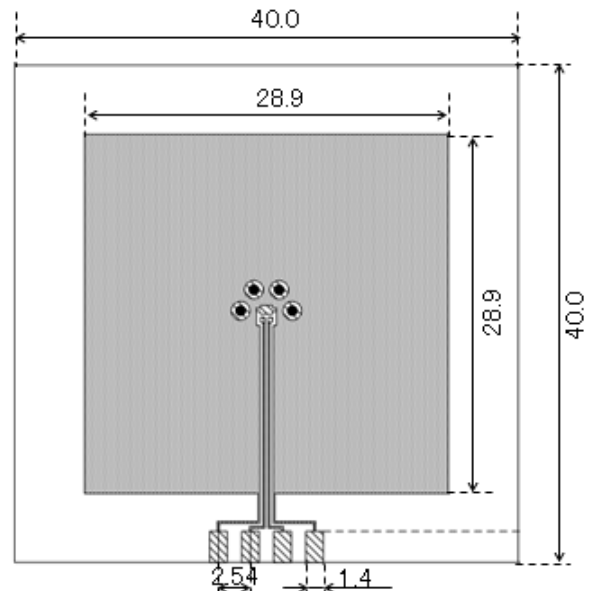

Evaluation Board (Unit: mm)

2. Power Dissipation vs. Ambient temperature

Board Mount (T_j max = 150°C)

Ambient Temperature (°C)	Power Dissipation Pd (mW)	Thermal Resistance (°C/W)
25	1000	125.00
150	0	

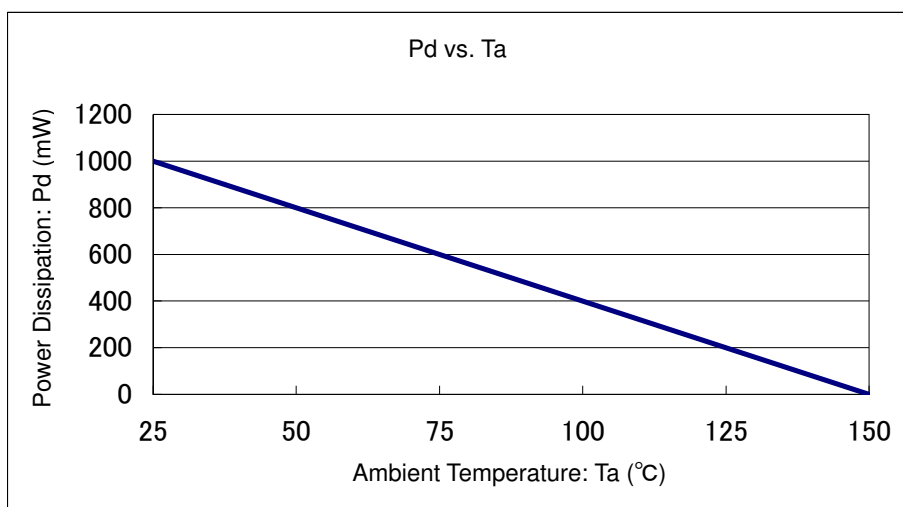

1. The products and product specifications contained herein are subject to change without notice to improve performance characteristics. Consult us, or our representatives before use, to confirm that the information in this datasheet is up to date.
2. We assume no responsibility for any infringement of patents, patent rights, or other rights arising from the use of any information and circuitry in this datasheet.
3. Please ensure suitable shipping controls (including fail-safe designs and aging protection) are in force for equipment employing products listed in this datasheet.
4. The products in this datasheet are not developed, designed, or approved for use with such equipment whose failure or malfunction can be reasonably expected to directly endanger the life of, or cause significant injury to, the user.
(e.g. Atomic energy; aerospace; transport; combustion and associated safety equipment thereof.)
5. Please use the products listed in this datasheet within the specified ranges.
Should you wish to use the products under conditions exceeding the specifications, please consult us or our representatives.
6. We assume no responsibility for damage or loss due to abnormal use.
7. All rights reserved. No part of this datasheet may be copied or reproduced without the prior permission of TOREX SEMICONDUCTOR LTD.

TOREX SEMICONDUCTOR LTD.