



Chipsmall Limited consists of a professional team with an average of over 10 year of expertise in the distribution of electronic components. Based in Hongkong, we have already established firm and mutual-benefit business relationships with customers from,Europe,America and south Asia,supplying obsolete and hard-to-find components to meet their specific needs.

With the principle of "Quality Parts,Customers Priority,Honest Operation,and Considerate Service",our business mainly focus on the distribution of electronic components. Line cards we deal with include Microchip,ALPS,ROHM,Xilinx,Pulse,ON,Everlight and Freescale. Main products comprise IC,Modules,Potentiometer,IC Socket,Relay,Connector.Our parts cover such applications as commercial,industrial, and automotives areas.

We are looking forward to setting up business relationship with you and hope to provide you with the best service and solution. Let us make a better world for our industry!



Contact us

Tel: +86-755-8981 8866 Fax: +86-755-8427 6832

Email & Skype: info@chipsmall.com Web: www.chipsmall.com

Address: A1208, Overseas Decoration Building, #122 Zhenhua RD., Futian, Shenzhen, China





XC112 Connector Board Product Brief



XC112 Connector Board Product Brief

Proprietary and Confidential

Author: Acconeer

Version 1.0: 2018-08-14



Table of Contents

1. Introduction	4
2. XC112 Connector Board	5
1.1 Overview	5
1.2 Power	7
1.3 Electrical Schematics	8
1.4 Bill of Material	13
1.5 Pinning	14
3. Revision History	16
4. Disclaimer	17



1. Introduction

The XC112 Connector Board is part of the Acconeer XC112-XR112 Evaluation Kit and is intended to be used together with the XR112. XC112 is equipped with FFC (Flat Flexible Cable) connectors to which up to four XR112 sensor boards can be connected. The flex cable solution enables a wide variety of use cases since the sensor board placement is not limited by the size of the connector board. The connector board has been designed for use with a Raspberry Pi 3.



2. XC112 Connector Board

1.1 Overview

Picture 1 shows the XC112 Connector Board, front side.

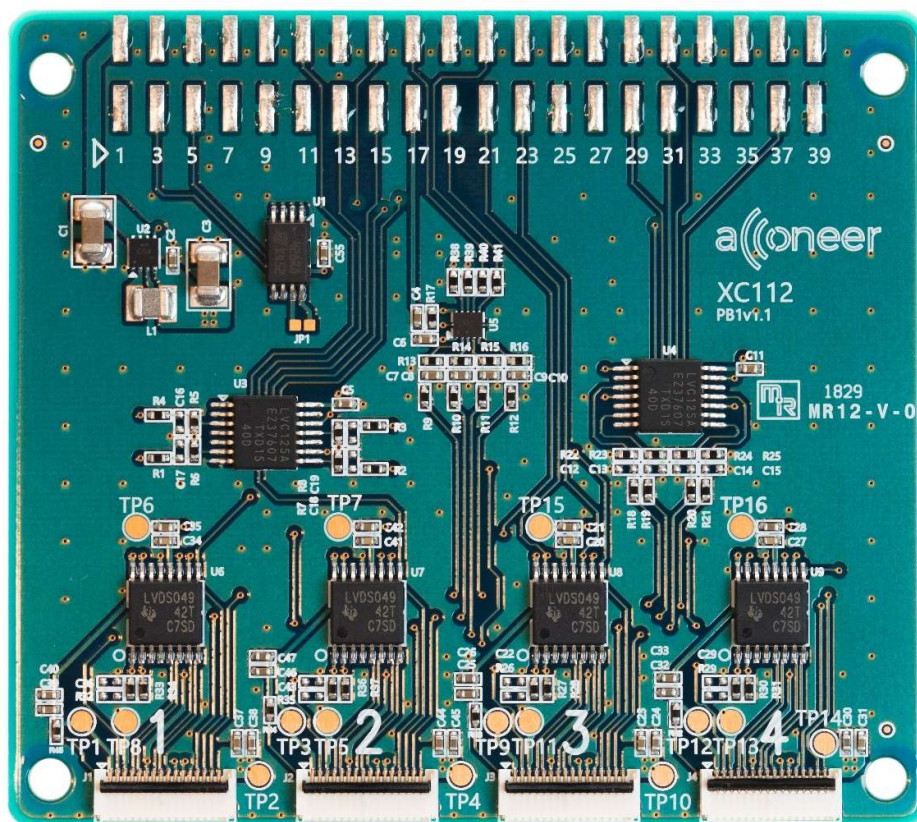



Picture 2 shows the reverse side of the XC112.

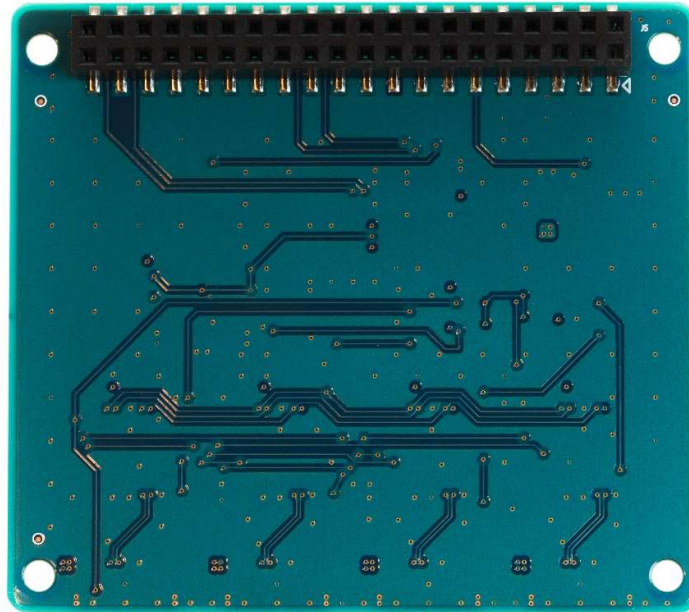

Picture 3 shows the XC112 and one sensor (XR112) connected.

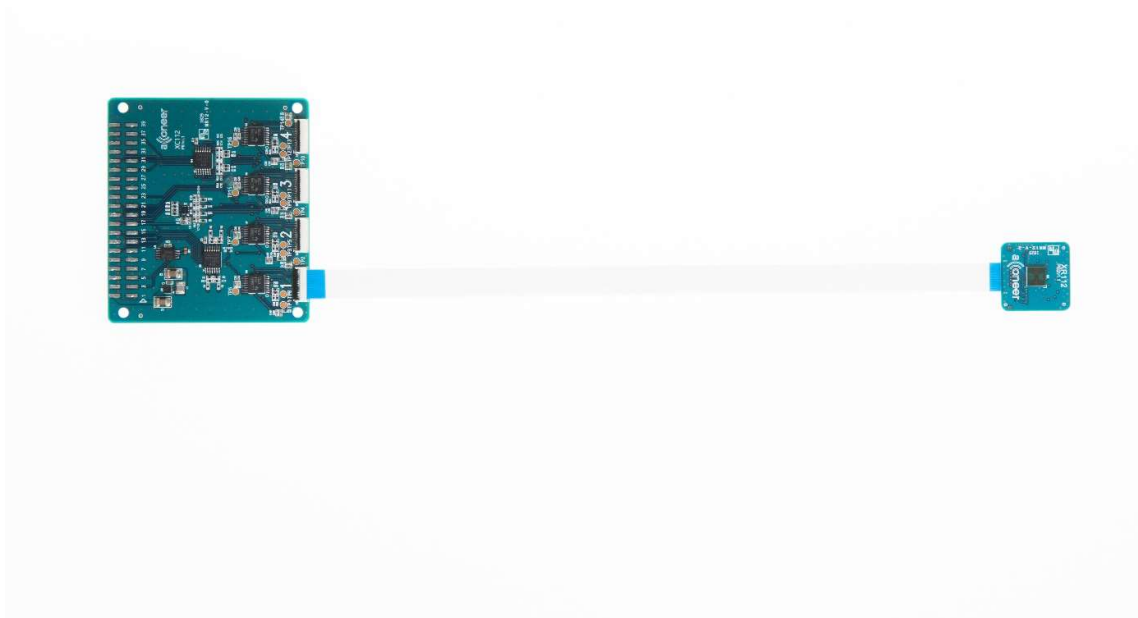



Picture 4 shows the XC112 connected with the Raspberry Pi.

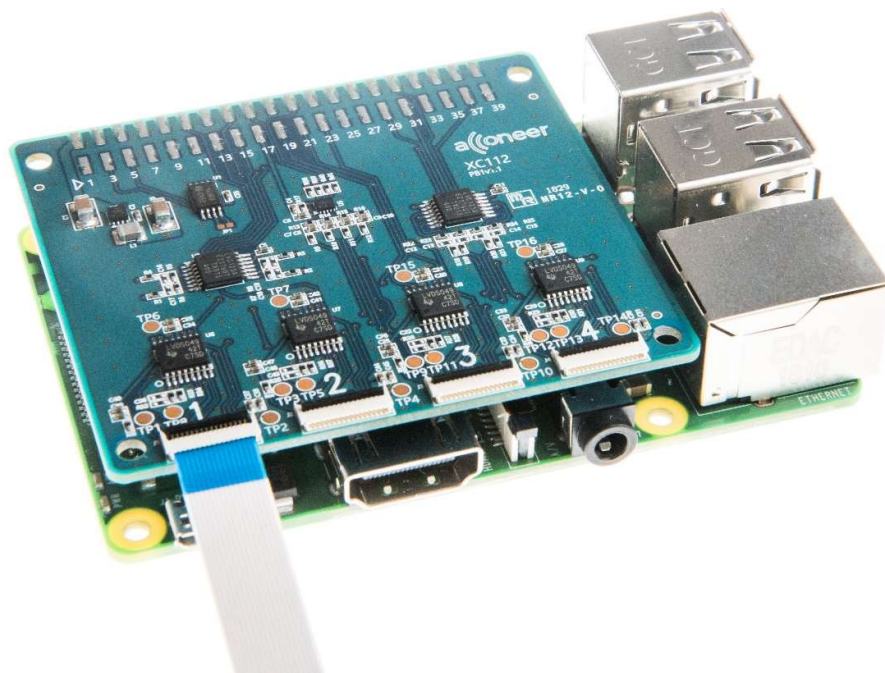

1.2 Power

The XC112 connector board is powered through the Raspberry Pi. When the power LED on the Raspberry Pi is lit, the board is powered on and ready for use.



1.3 Electrical Schematics

On the following pages, please find the electrical schematics for the XC112.

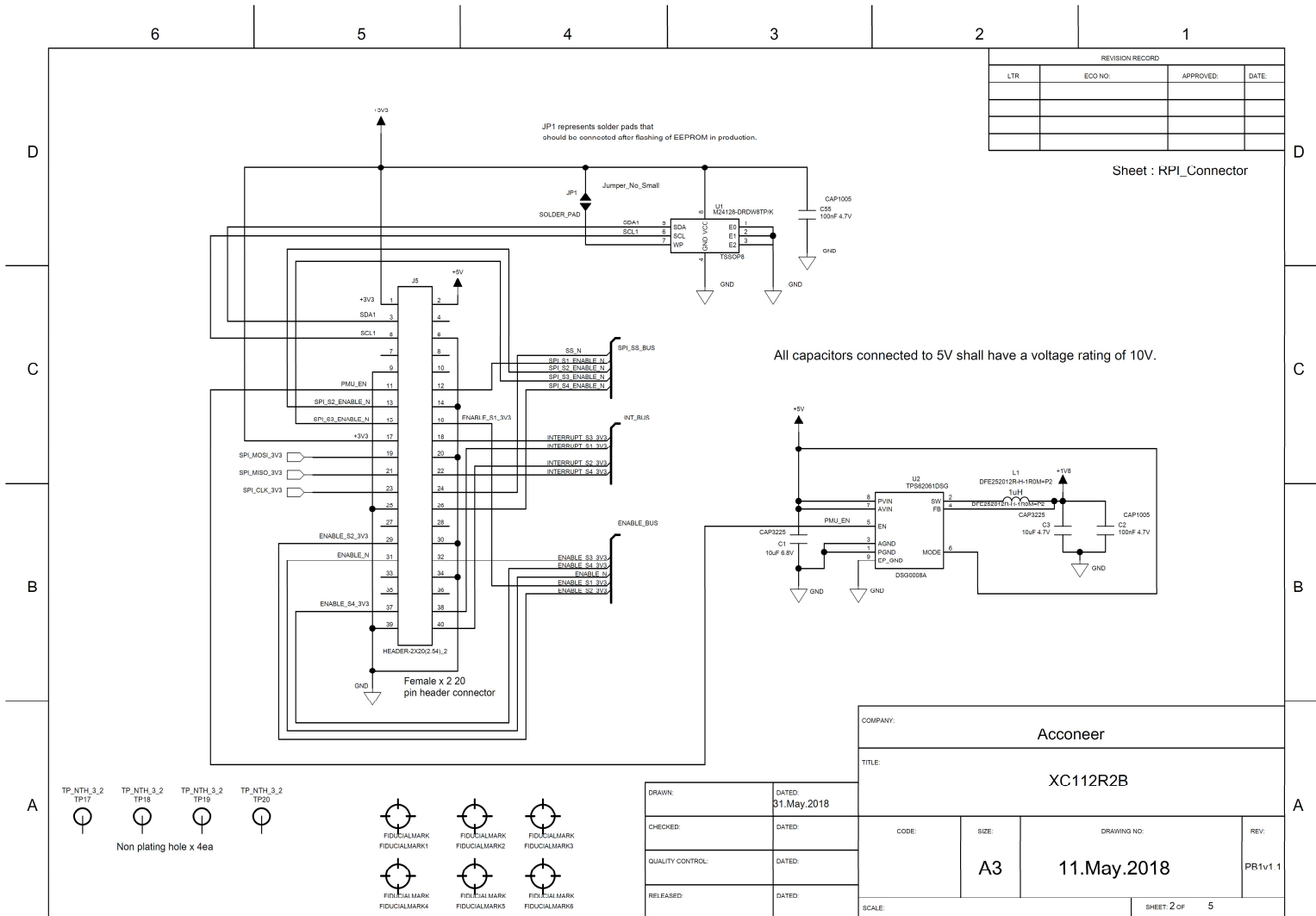

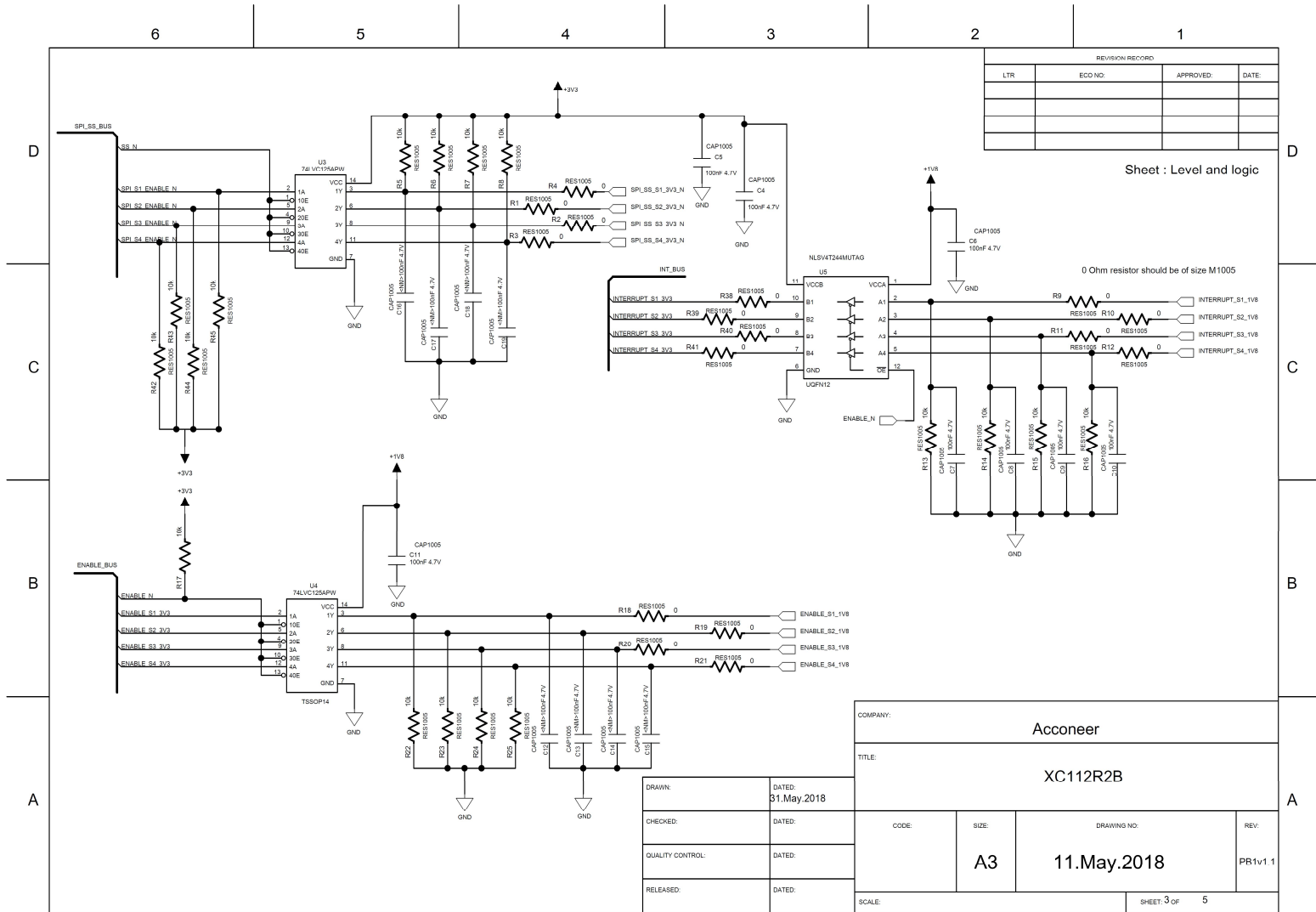

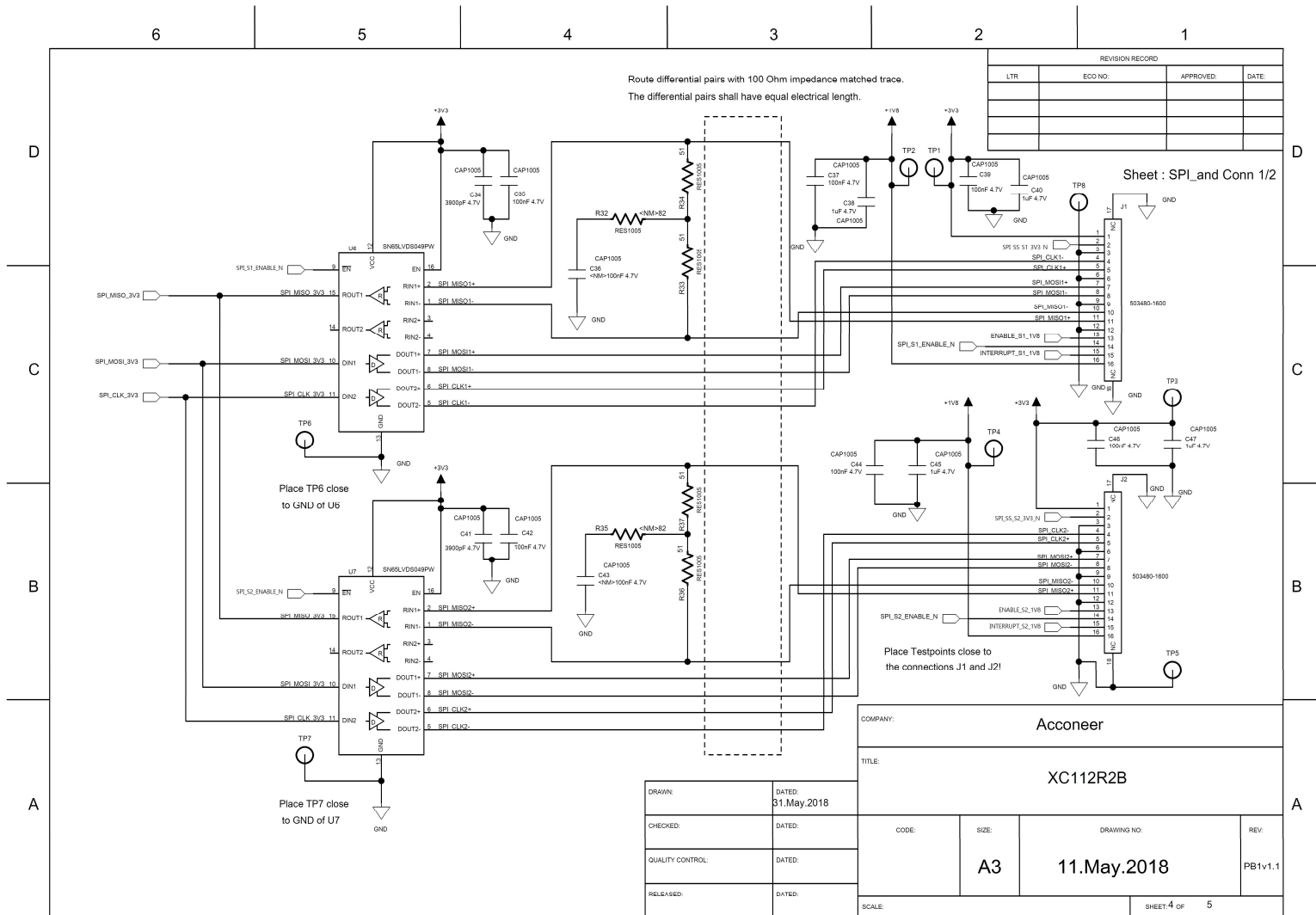

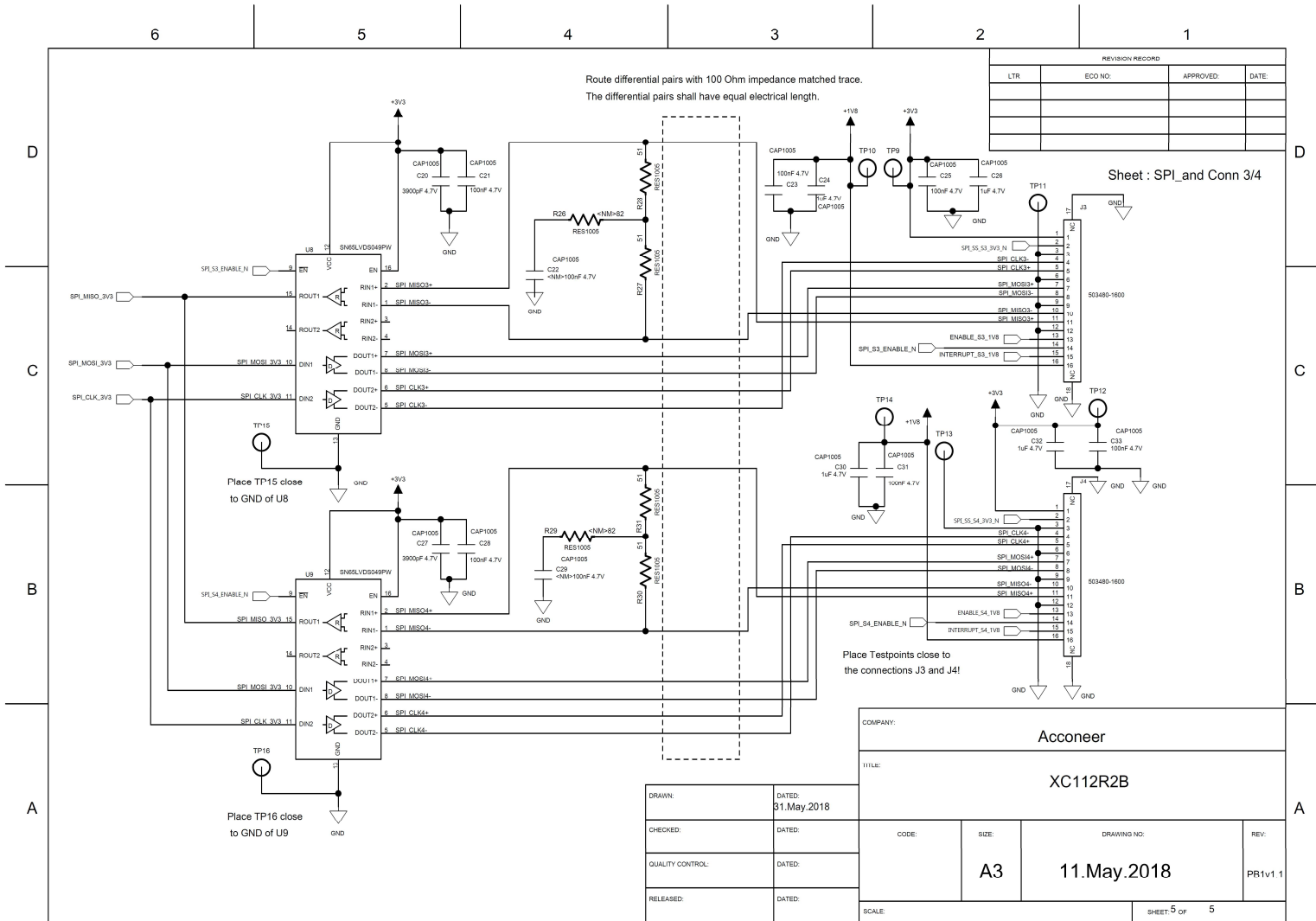



1.4 Bill of Material

Table 1 shows the BOM for the XC112

Component ref.	Part Number	QTY	Value	Comment
C1, C3	10/UF/K/X5R/50V/3216	2	10uF	
C10, C11, C2, C21, C23, C25, C28, C31, C33, C35, C37, C39, C4, C42, C44, C46, C5, C55, C6, C7, C8, C9	100/NF/J/50V/X5R/1005	22	100nF	
C20, C27, C34, C41	3.9/NF/K/50V/X7R/1005	4	3900pF	
C24, C26, C30, C32, C38, C40, C45, C47	1/UF/K/10V/X5R/1005	8	1uF	
L1	MURATA, DFE252012R-H- 1R0M=P2	1	1uH	
J1, J2, J3, J4	Molex 503480-1600	4		16Pin 0.5 FPCB CONN BACKFLIP
J5	CNC, JINLIN, FH254- 40DSMT/2.54MM 2*20 SMD	1		
R1, R10, R11, R12, R18, R19, R2, R20, R21, R3, R38, R39, R4, R40, R41, R9	0/OHM/J/1005	16	0Ohm	
R13, R14, R15, R16, R17, R22, R23, R24, R25, R5, R6, R7, R8, R42, R43, R44, R45	10/KOHM/F/1005	17	10kOhm	
R27, R28, R30, R31, R33, R34, R36, R37	51/OHM/J/1005	8	51Ohm	
U1	M24128-DRDW8TP/K	1		
U2	TPS62061DSGR	1		
U3, U4	74LVC125APW	2		
U5	NLSV4T244MUTAG	1		
U6, U7, U8, U9	SN65LVDS049PW	4		



1.5 Pinning

Table 2 shows the PIN connections for XC112.

Pin Number	Description
1	+3.3V
2	+5V
3	SDA1 connected to EEPROM
4	Not connected
5	SCL1 connected to EEPROM
6	GND
7	Not connected
8	Not connected
9	GND
10	Not connected
11	PMU_EN
12	SPI_S1_ENABLE_N, selects sensor 1 to respond to SS_N.
13	SPI_S2_ENABLE_N, selects sensor 2 to respond to SS_N.
14	GND
15	SPI_S3_ENABLE_N, selects sensor 3 to respond to SS_N.
16	ENABLE_S1_3V3, selects sensor 1 to respond to ENABLE_N.
17	+3.3V
18	INTERRUPT_S3_3V3, interrupt from sensor 3.
19	SPI_MOSI_3V3
20	GND
21	SPI_MISO_3V3
22	INTERRUPT_S4_3V3, interrupt from sensor 4.
23	SPI_CLK_3V3
24	SS_N, SPI slave select signal.
25	GND
26	SPI_S4_ENABLE_N, selects sensor 4 to respond to ENABLE_N.
27	Not connected
28	Not connected
29	ENABLE_S2_3V3, selects sensor 2 to respond to ENABLE_N.
30	GND
31	ENABLE_N, sensor enable signal.



Pin Number	Description
32	ENABLE_S3_3V3, selects sensor 3 to respond to ENABLE_N.
33	Not connected
34	GND
35	Not connected
36	Not connected
37	ENABLE_S4_3V3, selects sensor 4 to respond to ENABLE_N.
38	INTERRUPT_S1_3V3, interrupt from sensor 1.
39	GND
40	INTERRUPT_S2_3V3, interrupt from sensor 2.



3. Revision History

Date	Version	Changes
2018-08-24	1.0	Original Version



4. Disclaimer

The information herein is believed to be correct as of the date issued. Acconeer AB (“**Acconeer**”) will not be responsible for damages of any nature resulting from the use or reliance upon the information contained herein. Acconeer makes no warranties, expressed or implied, of merchantability or fitness for a particular purpose or course of performance or usage of trade. Therefore, it is the user’s responsibility to thoroughly test the product in their particular application to determine its performance, efficacy and safety. Users should obtain the latest relevant information before placing orders.

Unless Acconeer has explicitly designated an individual Acconeer product as meeting the requirement of a particular industry standard, Acconeer is not responsible for any failure to meet such industry standard requirements.

Unless explicitly stated herein this document Acconeer has not performed any regulatory conformity test. It is the user’s responsibility to assure that necessary regulatory conditions are met and approvals have been obtained when using the product. Regardless of whether the product has passed any conformity test, this document does not constitute any regulatory approval of the user’s product or application using Acconeer’s product.

Nothing contained herein is to be considered as permission or a recommendation to infringe any patent or any other intellectual property right. No license, express or implied, to any intellectual property right is granted by Acconeer herein.

Acconeer reserves the right to at any time correct, change, amend, enhance, modify, and improve this document and/or Acconeer products without notice.

This document supersedes and replaces all information supplied prior to the publication hereof.

