



Chipsmall Limited consists of a professional team with an average of over 10 year of expertise in the distribution of electronic components. Based in Hongkong, we have already established firm and mutual-benefit business relationships with customers from,Europe,America and south Asia,supplying obsolete and hard-to-find components to meet their specific needs.

With the principle of “Quality Parts,Customers Priority,Honest Operation,and Considerate Service”,our business mainly focus on the distribution of electronic components. Line cards we deal with include Microchip,ALPS,ROHM,Xilinx,Pulse,ON,Everlight and Freescale. Main products comprise IC,Modules,Potentiometer,IC Socket,Relay,Connector.Our parts cover such applications as commercial,industrial, and automotives areas.

We are looking forward to setting up business relationship with you and hope to provide you with the best service and solution. Let us make a better world for our industry!



Contact us

Tel: +86-755-8981 8866 Fax: +86-755-8427 6832

Email & Skype: info@chipsmall.com Web: www.chipsmall.com

Address: A1208, Overseas Decoration Building, #122 Zhenhua RD., Futian, Shenzhen, China



XC2404A816UR-G

1.6GHz Low Noise Amplifier

■ GENERAL DESCRIPTION

XC2404 series is an ultra-low-noise amplifier (LNA) with low operating voltage, low noise figure, low power consumption. The device offers easy output matching to 50Ω for input and output with less external components.

The device operates at 1.2V. For higher power supplies such as 1.8V and 2.85V, the device can operate with a self bias of one adding resistor.

■ APPLICATIONS

- GPS band RF signal amplified

■ FEATURES

- Noise Figure : NF=0.94dB(TYP.) @ 1.575GHz
- Low Power Consumption : 12.0mW(TYP.) @ V_{DD}=1.2V, Fixed bias
- High Gain : |S₂₁|=26.5dB(TYP.) @ 1.575GHz
- Operation Voltage Range : 1.14V ~ 1.26V @ Fixed bias
- Output : CMOS Output, 50Ω driver built-in
- Operating Temperature Range : -40°C ~ +85°C
- Ultra Small Package : USP-8A01
- Environmentally Friendly : EU RoHS Compliant, Pb Free

■ TYPICAL APPLICATION CIRCUIT

Figure 1: Fixed Bias

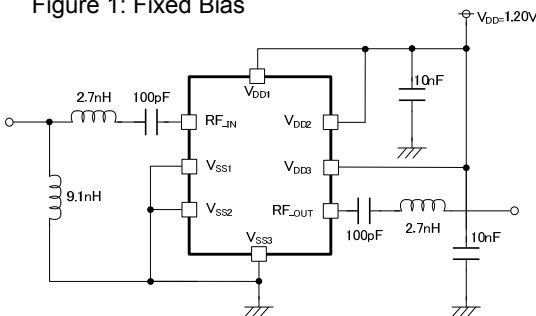
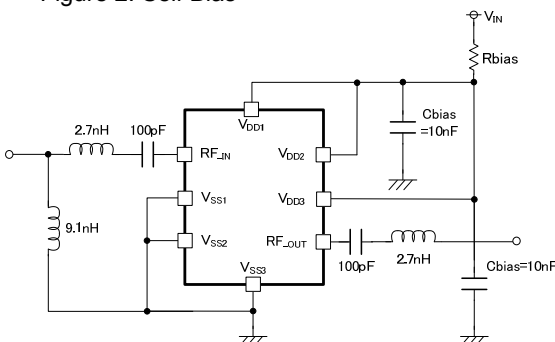

Figure 2: Self Bias



V _{IN} [V]	R _{BIAS} [Ω]
3.00	270
2.85	240
1.80	82

* R_{BIAS} should be in ± 1% tolerance and ± 200ppm/°C temperature stability.
C_{BIAS} is 10nF.

■ TYPICAL PERFORMANCE CHARACTERISTICS

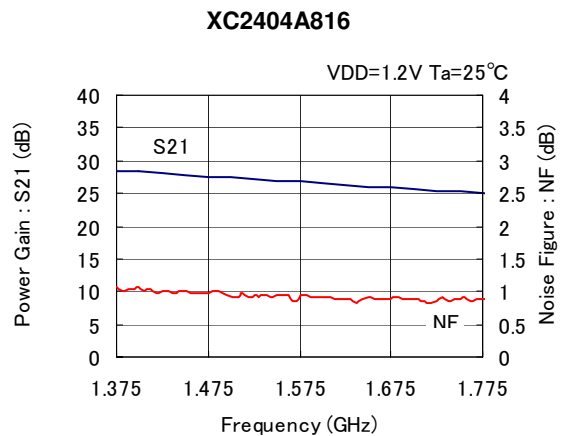

■ PIN CONFIGURATION

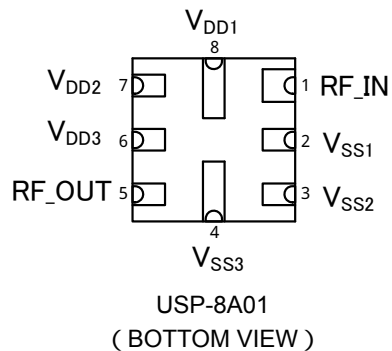

■ PIN ASSIGNMENT

PIN NUMBER	PIN NAME	FUNCTION
USP-8A01		
1	RF_IN	RF Signal Input
2	V _{SS1}	Ground
3	V _{SS2}	Ground
4	V _{SS3}	Ground
5	RF_OUT	RF Signal Output
6	V _{DD3}	Power Supply
7	V _{DD2}	Power Supply
8	V _{DD1}	Power Supply

■ PRODUCT CLASSIFICATION

- Ordering Information

XC2404A816①②-③ ^(*)

DESIGNATOR	DESCRIPTION	SYMBOL	DESCRIPTON
①②-③	Packages Taping Type	UR-G	USP-8A01

(*) The “-G” suffix indicates that the products are Halogen and Antimony free as well as being fully RoHS compliant.

■ BLOCK DIAGRAMS

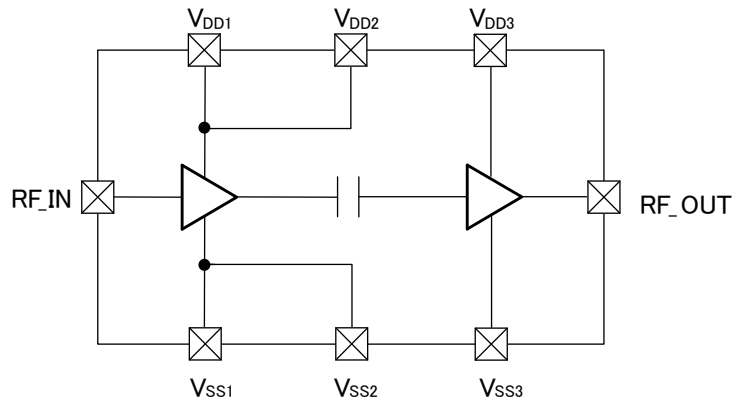

■ ABSOLUTE MAXIMUM RATINGS

T_a=25°C

PARAMETER	SYMBOL	RATINGS	UNITS
Supply Voltage	V _{DD}	1.60	V
Current Circuit	I _{DD}	42	mA
RF Input Power	P _{IN}	10	dBm
Power Dissipation	P _d	120	mW
Operating Temperature Range	T _a	-40 ~ +85	°C
Storage Temperature Range	T _{stg}	-55 ~ +125	°C

■ ELECTRICAL CHARACTERISTICS

• DC Characteristics

Fixed Bias (refer to TYPICAL APPLICATION CIRCUIT, Figure 1)

Ta=25°C

PARAMETER	SYMBOL	CONDITIONS	MIN.	TYP.	MAX.	UNITS	CIRCUITS
Power Supply Pin Voltage	V _{DD}	-	1.14	1.20	1.26	V	①
Current Circuit	I _{DD}	V _{DD} =1.2V	4.00	10.0	18	mA	①

Self Bias (refer to TYPICAL APPLICATION CIRCUIT, Figure 2)

Ta=25°C

PARAMETER	SYMBOL	CONDITIONS	MIN.	TYP.	MAX.	UNITS	CIRCUITS
Input Power Supply Voltage 1	V _{IN1}	R _{BIAS} =270Ω ± 1%, ± 200ppm/°C	2.850	3.000	3.150	V	①
Input Power Supply Voltage 2	V _{IN2}	R _{BIAS} =240Ω ± 1%, ± 200ppm/°C	2.708	2.850	2.992	V	①
Input Power Supply Voltage 3	V _{IN3}	R _{BIAS} =82Ω ± 1%, ± 200ppm/°C	1.710	1.800	1.890	V	①
Power Supply Pin Voltage	V _{DD}	V _{IN} = V _{IN1} , V _{IN2} , V _{IN3}	0.90	1.12	1.32	V	①
Current Circuit	I _{DD}	V _{IN} = V _{IN1} , V _{IN2} , V _{IN3}	5.25	7.25	11.0	mA	①

* When the device is used in self bias, please use the specified R_{BIAS} and C_{BIAS}.

■ ELECTRICAL CHARACTERISTICS (Continued)

• AC Characteristics

 $V_{DD}=1.2V, T_a=25^{\circ}C$

PARAMETER	SYMBOL	CONDITIONS	MIN.	TYP.	MAX.	UNITS	CIRCUITS
Power Gain	S21	f=1.575GHz	24	26.5	-	dB	②
Input Return Loss	S11	f=1.575GHz	-	10	-	dB	②
Output Return Loss	S22	f=1.575GHz	-	17	-	dB	②
Isolation	S12	f=1.575GHz	-	-36	-	dB	②
Noise Figure ^(*)	NF	f=1.575GHz	-	0.94	-	dB	③
Input Power IP3	I _{IP3}	f=1.575GHz, 1.576GHz	-	-14.5	-	dBm	④
Input Power @ 1dB Gain Compression	P1dB	f=1.575GHz	-	-25.5	-	dBm	②

*1: NF is the value excluding the substrate loss.

Note

- This series is structurally weak in electrostatic discharge.
Please eliminate static electricity from the operational table, people, and soldering iron.
- Please use noiseless power supply for stable operation.
- Please use $\pm 1\%$ Rbias with $\pm 200\text{ppm}/^{\circ}C$ temperature stability and 10nF Cbias.
- Please connect Cbias to V_{DD} pin as close as possible.
- Please refer to the pattern layout. V_{DD} pins ($V_{DD1}, V_{DD2}, V_{DD3}$) should be connected each other outside. Also, V_{SS} pins ($V_{SS1}, V_{SS2}, V_{SS3}$) should be connected as well.
- Please ensure to use an external component which does not depend on bias or temperature too much.

■ TEST CIRCUITS

- Circuit ① (DC Characteristics: Power Supply Pin Voltage, Circuit Current, Input Power Supply Voltage)

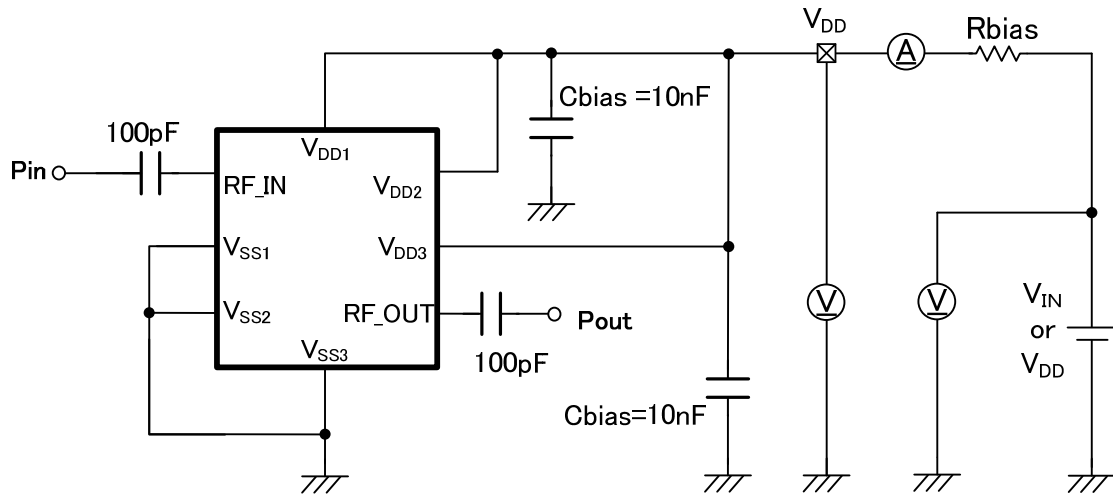

* Fixed Bias: $R_{bias}=0\Omega$, $V_{IN}=V_{DD}$
 ** Pin / Pout is 50Ω

- Circuit ② (Power Gain, Input Return Loss, Output Return Loss, Isolation, Input Power @ 1dB Gain Compression)

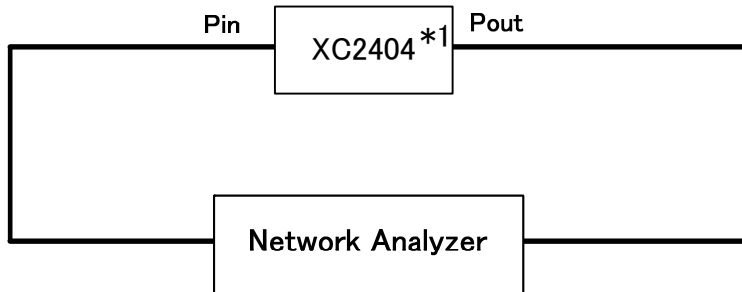

*1: Refer to the circuit ⑤ for the block detail.

- Circuit ③ (Noise Figure)

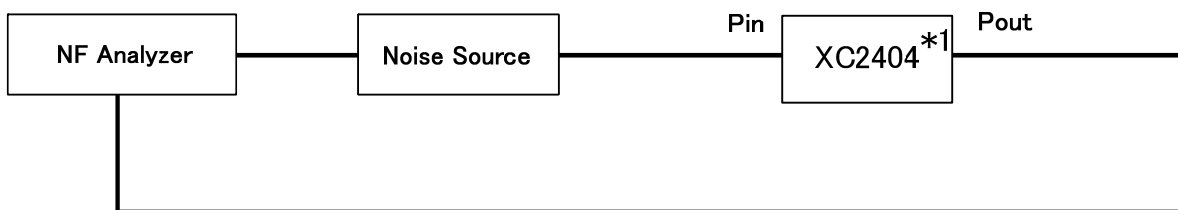

*1: Refer to the circuit ⑤ for the block detail.

■ TEST CIRCUITS (Continued)

- Circuit ④ (Input Power IIP3)

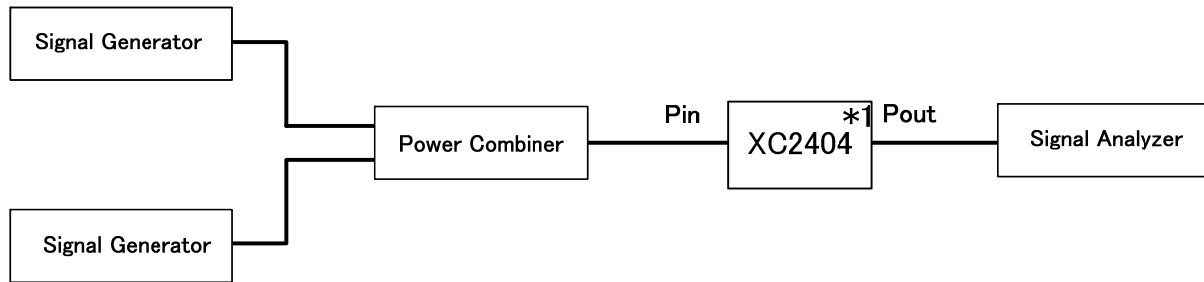

*1: Refer to the circuit ⑤ for the block detail.

- Circuit ⑤ (XC2404 series, the circuit of the block)

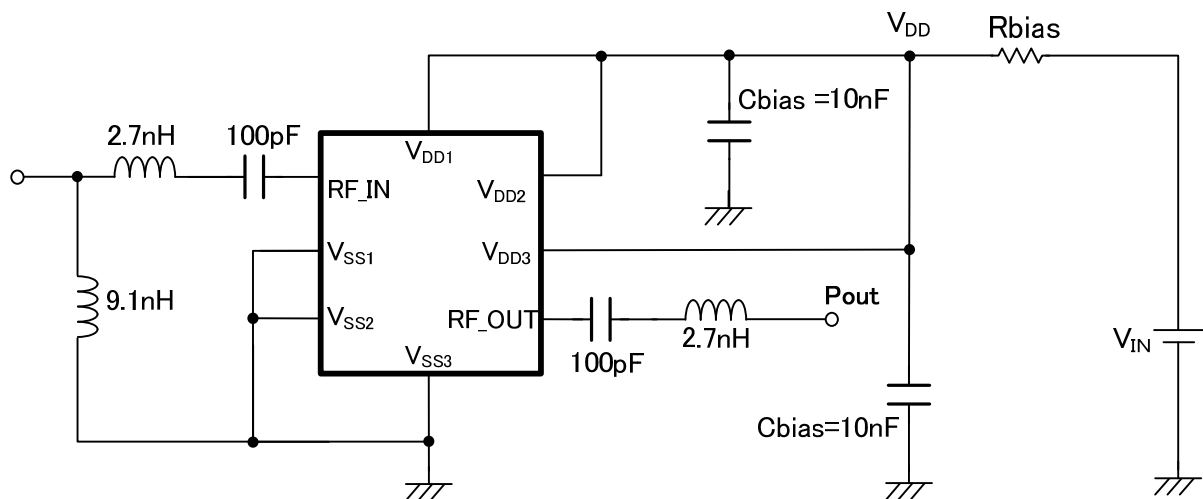

$V_{IN}(V)$	$R_{bias}(\Omega)$
3.00	270
2.85	240
1.80	82

* Fixed Bias: $R_{bias}=0\Omega$, $V_{IN}=V_{DD}$

** R_{bias} : Should be in $\pm 1\%$ tolerance and $\pm 200\text{ppm}/^\circ\text{C}$ temperature stability. C_{bias} is 10nF.

*** Please refer to the EVALUATION BOARD layout. V_{DD} pin (V_{DD1} , V_{DD2} , V_{DD3}) and V_{SS} pin (V_{SS1} , V_{SS2} , V_{SS3}) are connected respectively on the board.

XC2404A816UR-G

■ EVALUATION BOARD

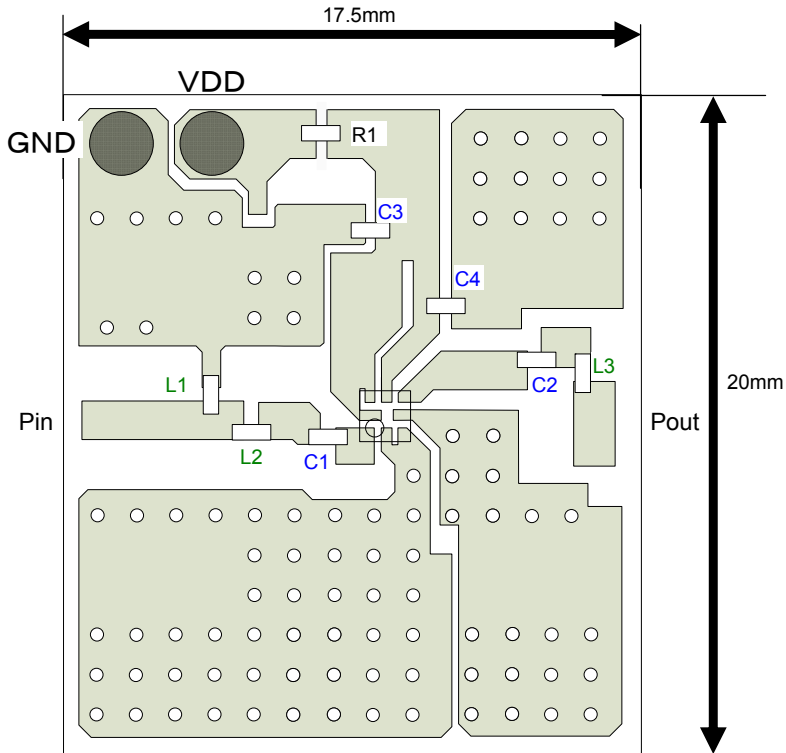

SYMBOL	SPEC	COMMENT
C1, C2	100pF	MURATA (GRM1552C1H)
C3,C4	10nF	-
L1	9.1nH	TAIYO YUDEN AQseries (AQ1059N1J)
L2,L3	2.7nH	TAIYO YUDEN AQseries (AQ1052N7J)
R1 (Rbias) ^(*)	- ^(*)	Less than ± 1% tolerance, Less than ± 200ppm/°C temperature stability

PCB (FR-4)
 MICROSTRIPLINE WIDTH =1.25mm
 t=0.8mm
 PCB size = 20mm× 17.5mm

*1: Fixed Bias: Rbias=0Ω

* Please use an external component which does not depend on bias or temperature too much.

■ TYPICAL PERFORMANCE CHARACTERISTICS

(1) Current Circuit vs. Supply Voltage

XC2404A816

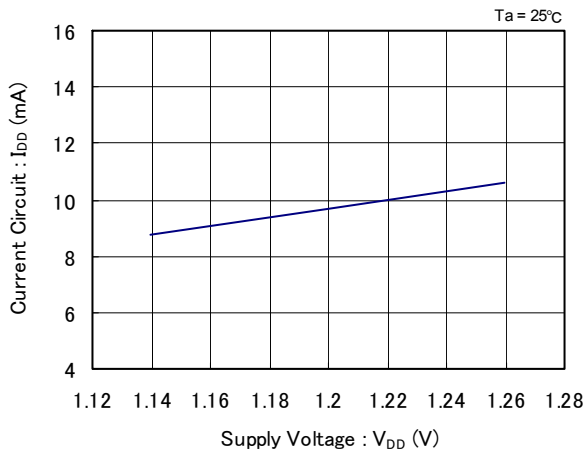

(2) Power Gain vs. Supply Voltage

XC2404A816

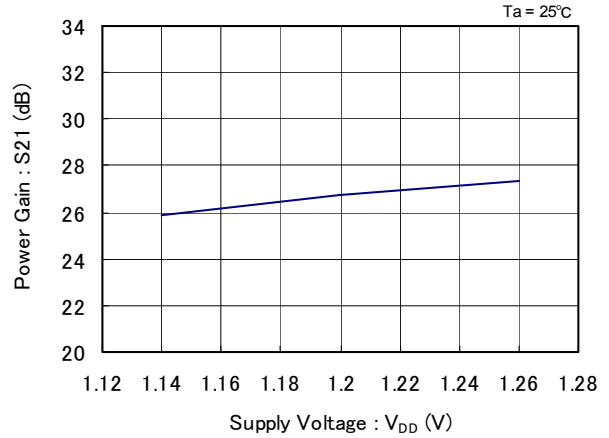

(3) Input Return Loss vs. Supply Voltage

XC2404A816

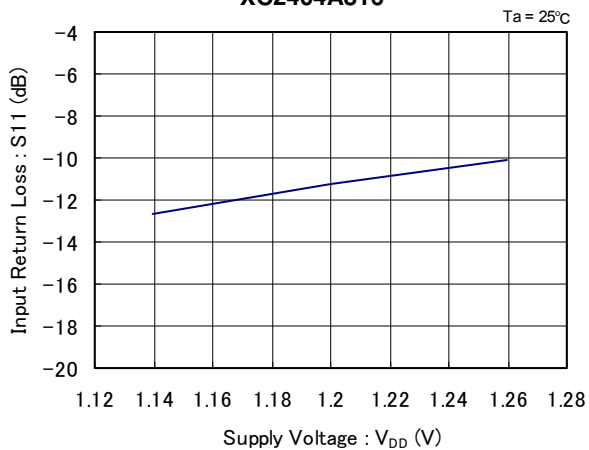

(4) Output Return Loss vs. Supply Voltage

XC2404A816

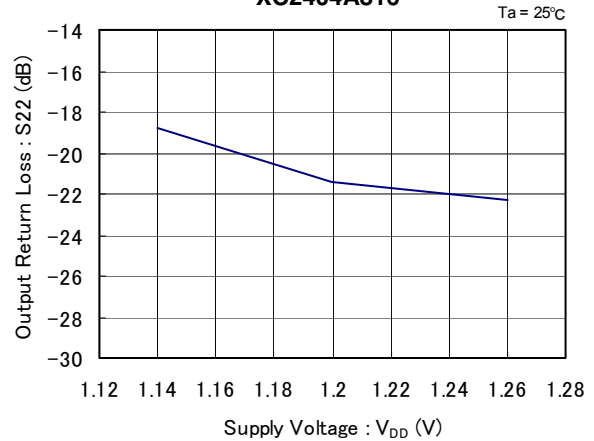

(5) Isolation vs. Supply Voltage

XC2404A816

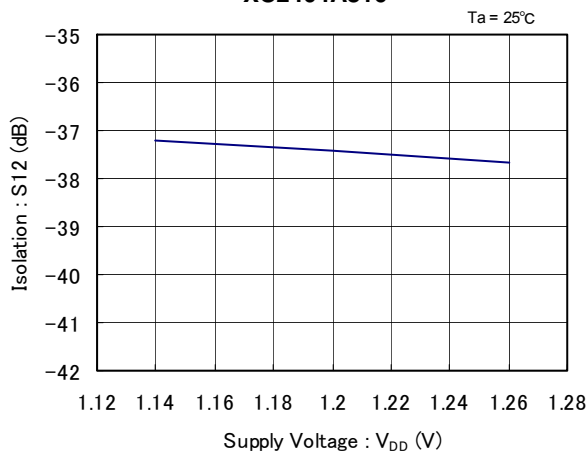

(6) Noise Figure vs. Supply Voltage

XC2404A816

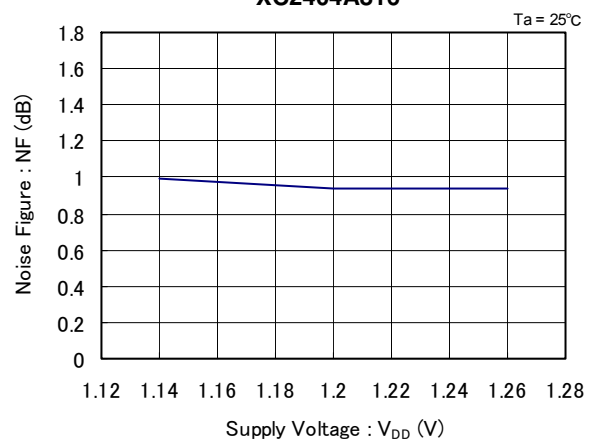

■ TYPICAL PERFORMANCE CHARACTERISTICS (Continued)

(7) Input 3 Order Intercept Point vs. Supply Voltage

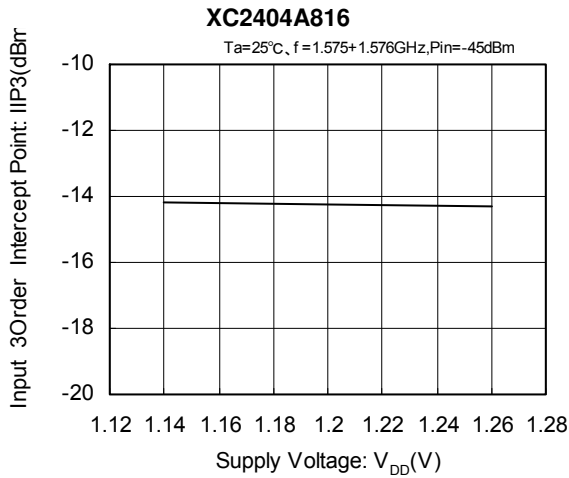

(8) Input Power @ 1dB Gain Compression vs. Power Supply Voltage

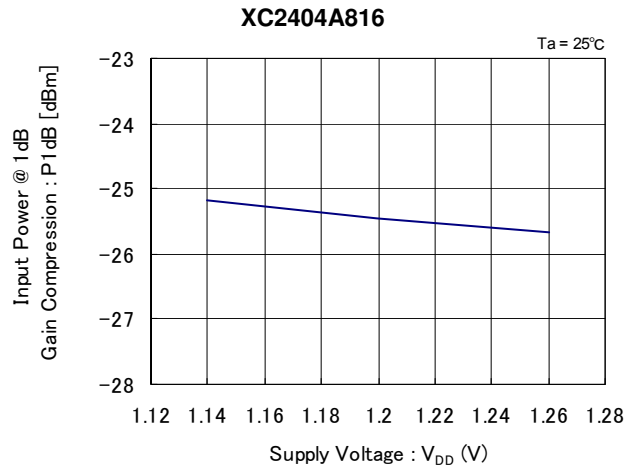

(9) Supply Current vs. Ambient Temperature

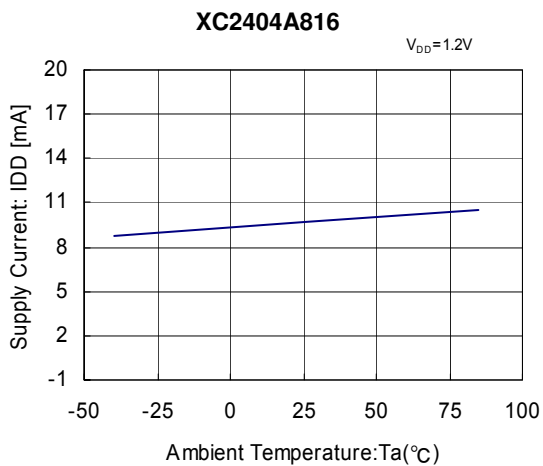

(10) Power Gain vs. Ambient Temperature

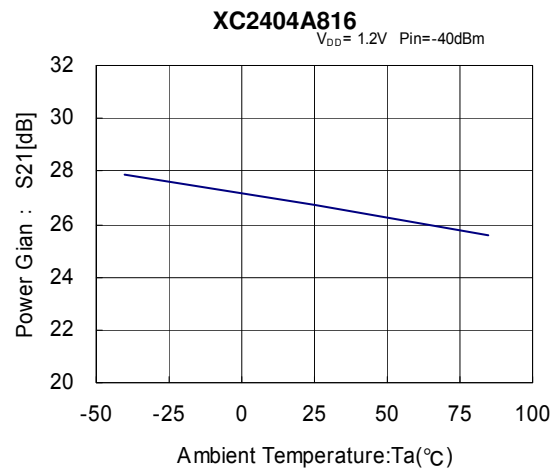

(11) Input Return Loss vs. Ambient Temperature

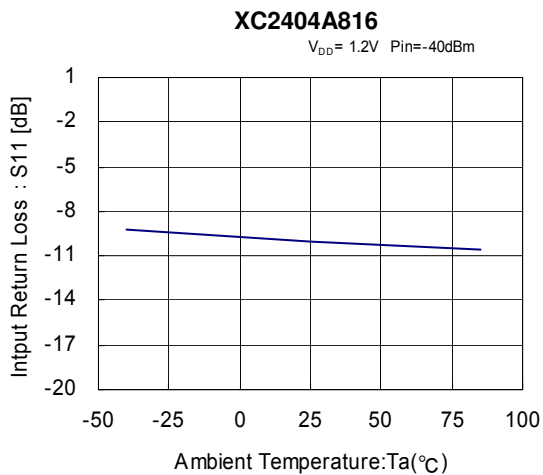

(12) Output Return Loss vs. Ambient Temperature

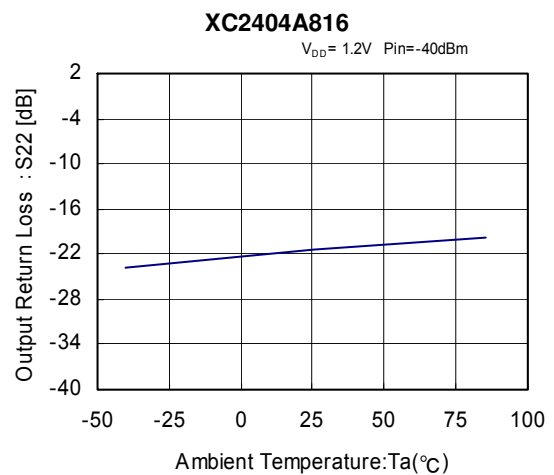

■ TYPICAL PERFORMANCE CHARACTERISTICS (Continued)

(13) Reverse Isolation vs. Ambient Temperature

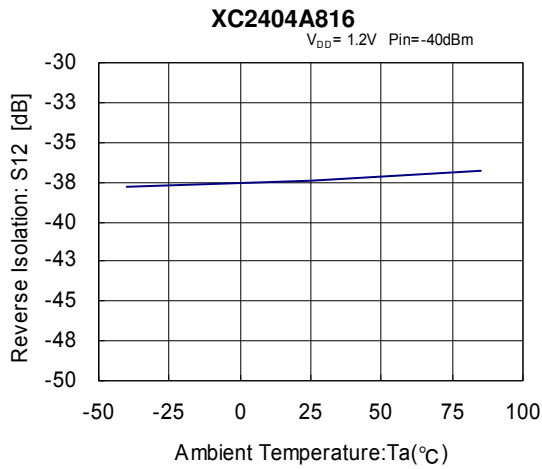

(14) Noise Figure vs. Ambient Temperature

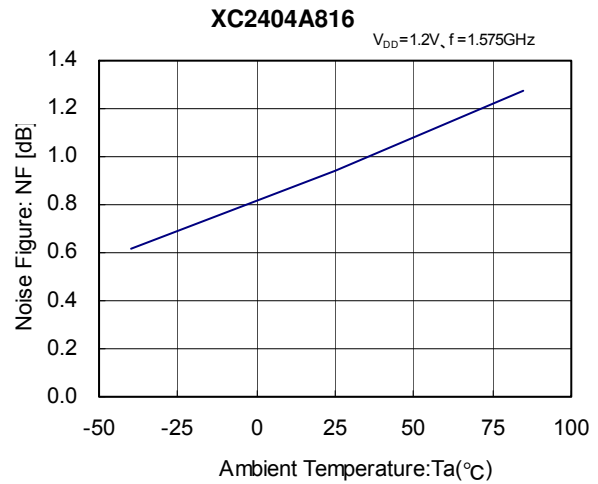

(15) Input 3 Order intercept point vs. Ambient Temperature

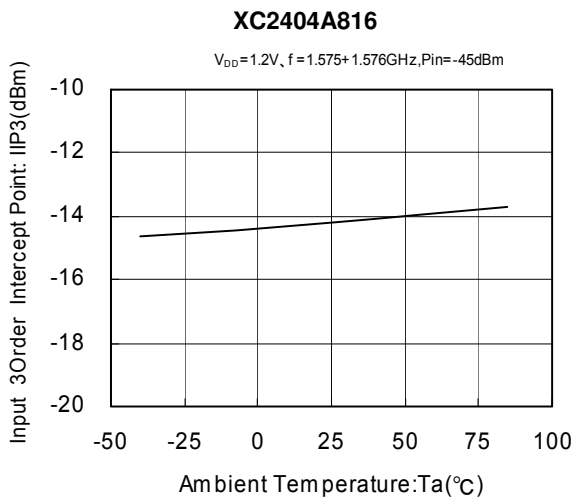

(16) Input Power @ 1dB Gain Compression vs. Ambient Temperature

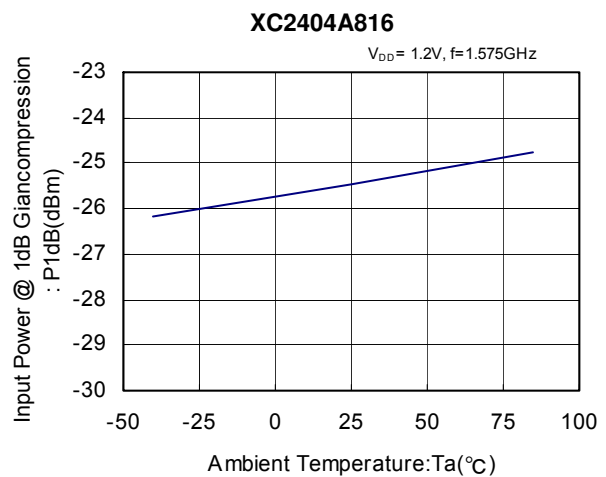

(17) Power Gain vs. Frequency

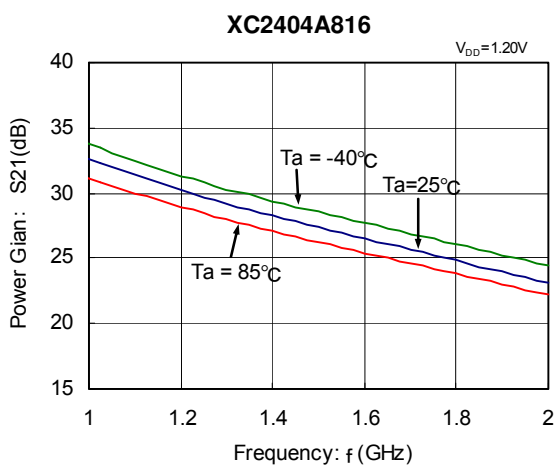

(18) Input Return Loss vs. Frequency

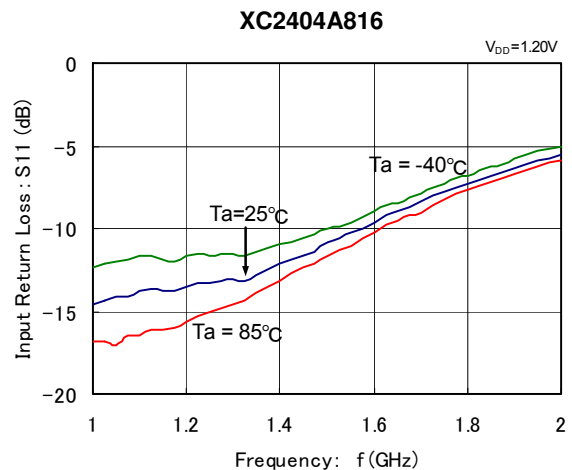

XC2404A816UR-G

■ TYPICAL PERFORMANCE CHARACTERISTICS (Continued)

(19) Output Return Loss vs. Frequency

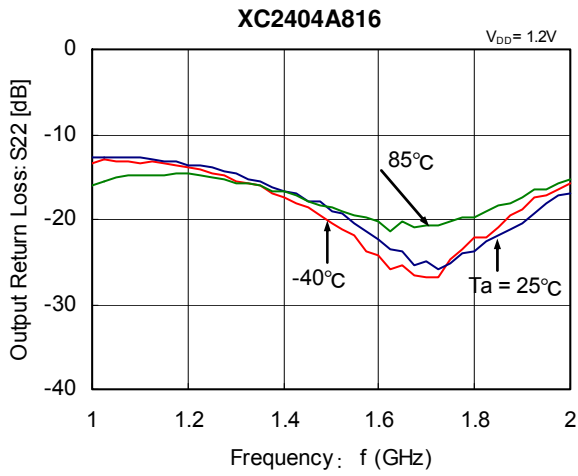

(20) Isolation vs. Frequency

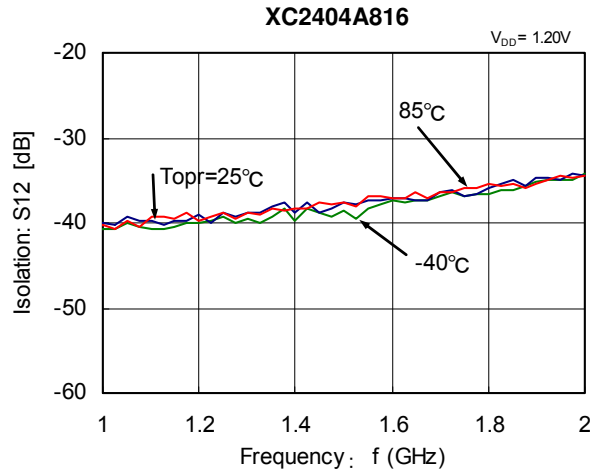

(21) Input Return Loss vs. Frequency (Smith Chart)

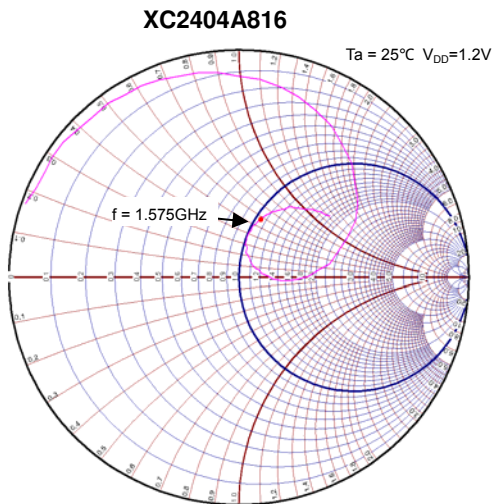

(22) Output Return Loss vs. Frequency (Smith Chart)

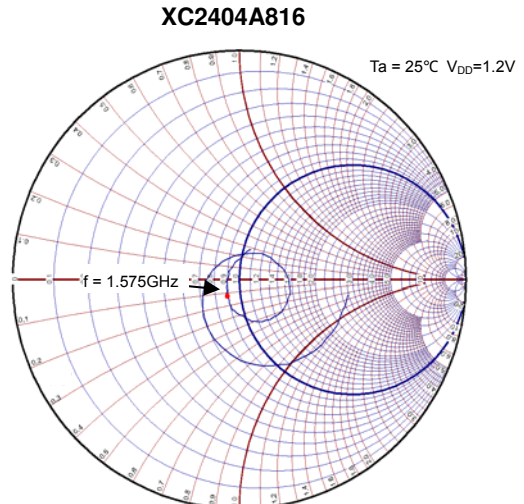

(23) Noise Figure vs. Frequency

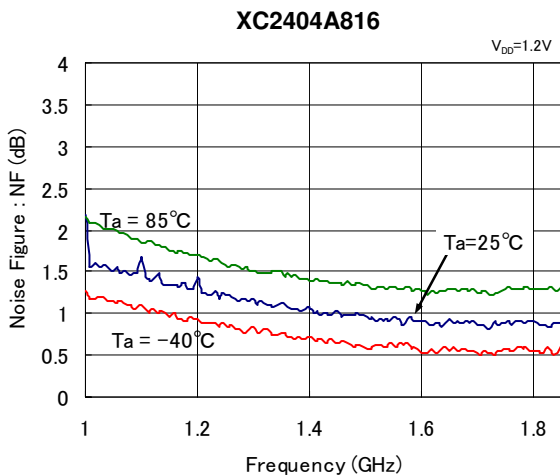

(24) Power Gain vs. Input Power

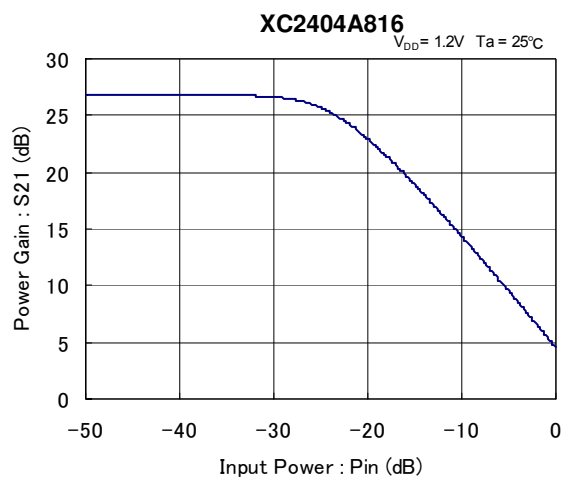

■ MARKING RULE

① represents product series.

MARK	PRODUCT SERIES
4	XC2404*****-G

②③ represents product.

MARK		PRODUCT SERIES
②	③	
A	0	XC2404A816**-G

④⑤ represents production lot number.

01 to 09, 0A to 0Z, 11 to 9Z, A1 to A9, AA to Z9, ZA to ZZ in order.

(G, I, J, O, Q, W excepted)

*No character inversion used.

USP-8A01

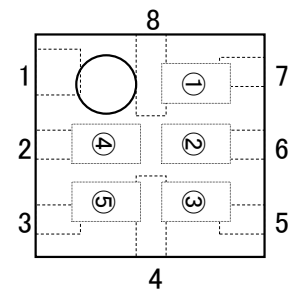

1. The products and product specifications contained herein are subject to change without notice to improve performance characteristics. Consult us, or our representatives before use, to confirm that the information in this datasheet is up to date.
2. We assume no responsibility for any infringement of patents, patent rights, or other rights arising from the use of any information and circuitry in this datasheet.
3. Please ensure suitable shipping controls (including fail-safe designs and aging protection) are in force for equipment employing products listed in this datasheet.
4. The products in this datasheet are not developed, designed, or approved for use with such equipment whose failure or malfunction can be reasonably expected to directly endanger the life of, or cause significant injury to, the user.
(e.g. Atomic energy; aerospace; transport; combustion and associated safety equipment thereof.)
5. Please use the products listed in this datasheet within the specified ranges.
Should you wish to use the products under conditions exceeding the specifications, please consult us or our representatives.
6. We assume no responsibility for damage or loss due to abnormal use.
7. All rights reserved. No part of this datasheet may be copied or reproduced without the prior permission of TOREX SEMICONDUCTOR LTD.

TOREX SEMICONDUCTOR LTD.