



Chipsmall Limited consists of a professional team with an average of over 10 year of expertise in the distribution of electronic components. Based in Hongkong, we have already established firm and mutual-benefit business relationships with customers from,Europe,America and south Asia,supplying obsolete and hard-to-find components to meet their specific needs.

With the principle of “Quality Parts,Customers Priority,Honest Operation,and Considerate Service”,our business mainly focus on the distribution of electronic components. Line cards we deal with include Microchip,ALPS,ROHM,Xilinx,Pulse,ON,Everlight and Freescale. Main products comprise IC,Modules,Potentiometer,IC Socket,Relay,Connector.Our parts cover such applications as commercial,industrial, and automotives areas.

We are looking forward to setting up business relationship with you and hope to provide you with the best service and solution. Let us make a better world for our industry!



Contact us

Tel: +86-755-8981 8866 Fax: +86-755-8427 6832

Email & Skype: info@chipsmall.com Web: www.chipsmall.com

Address: A1208, Overseas Decoration Building, #122 Zhenhua RD., Futian, Shenzhen, China



C_L Capacitor-Less 500mA Low Power Consumption High Speed LDO Regulator

■ GENERAL DESCRIPTION

The XC6503 series is a 500mA high speed CMOS LDO regulator that can provide stable output voltages even without a load capacitor C_L. The devices are available in fixed output voltage from 1.2V to 5.0V in 0.05V increments

The C_L capacitor-less is possible because phase compensation is carried out internally unlike other LDOs where it is done externally. It results in saving board design space. The current limit fold-back circuit and thermal shutdown circuit work as protection circuit. The XC6503P is a 3-Terminal regulator and the XC6503D has a chip enable function, which enables the entire circuit to be turned off by a low level input signal to the CE pin.

When a C_L capacitor is used, the IC can discharge the electric charge stored at the output capacitor through the internal switch while in standby state, and as a result the V_{OUT} quickly returns to the V_{SS} level.

■ APPLICATIONS

- Smart phones / Mobile phones
- Portable game consoles
- Modules (wireless, cameras, etc.)
- Bluetooth modules
- Digital TV tuner modules

■ FEATURES

Maximum Output Current	: 500mA
Input Voltage Range	: 1.7V ~ 6.0V
Output Voltage Range	: 1.2V ~ 5.0V (0.05V increments)
Output Accuracy	: ±1.0% (2.0V~5.0V) ±20mV (1.2V~1.95V)
Temperature Stability	: ±30ppm/°C
Dropout Voltage	: 190mV@V _{OUT} =2.8V, I _{OUT} =300mA
Low Power Consumption	: 15 μA (TYP.), 0.1 μA (in standby)
High PSRR	: 55dB@1kHz, V _{OUT} =2.8V
Protection Current	: Current Limiter (630mA TYP.) Short-circuit Protection Thermal Shutdown
C _L Capacitor-Less	: Internal Phase Compensation
Operating Ambient Temperature	: -40°C~+85°C
Packages	: USP-4, SOT-25, SOT-89-5 (XC6503D) SOT-89 (XC6503P)
Environmentally Friendly	: EU RoHS Compliant, Pb Free

■ TYPICAL APPLICATION CIRCUIT

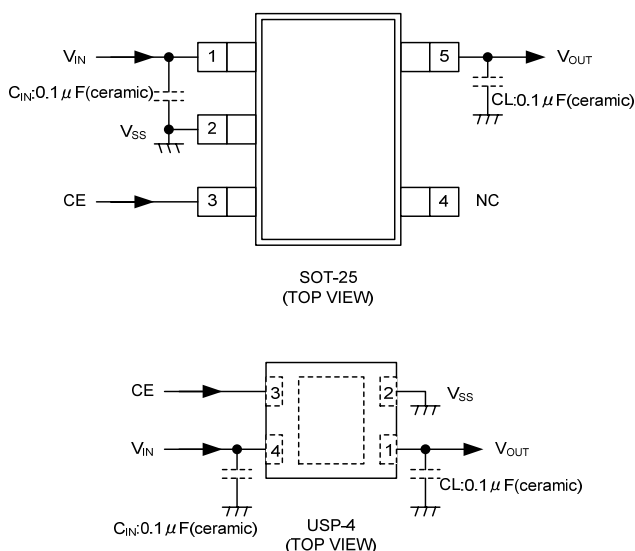

■ TYPICAL PERFORMANCE CHARACTERISTICS

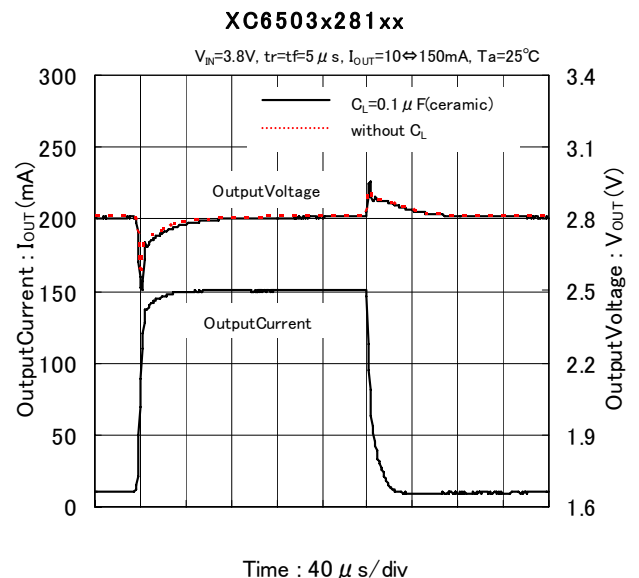

PIN CONFIGURATION

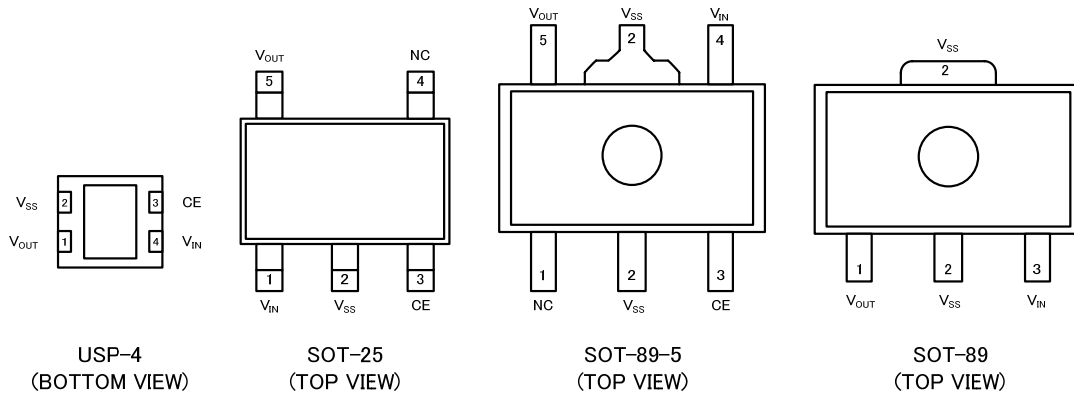

*The dissipation pad for the USP-4 package should be solder-plated in reference mount pattern and metal masking so as to enhance mounting strength and heat release. If the pad needs to be connected to other pins, it should be connected to the V_{SS} (No. 2) pin.

PIN ASSIGNMENT

PIN NUMBER				PIN NAME	FUNCTIONS
USP-4	SOT-25	SOT89-5	SOT-89		
4	1	4	3	V_{IN}	Power Input
1	5	5	1	V_{OUT}	Output
2	2	2	2	V_{SS}	Ground
3	3	3	-	CE	ON/OFF Control
-	4	1	-	NC	No Connection

PIN FUNCTION ASSIGNMENT

XC6503 Series (D Type)

PIN NAME	LOGIC	IC OPERATION
CE	L	Operation OFF
	H	Operation ON
	OPEN	Operation OFF

■ PRODUCT CLASSIFICATION

● Ordering Information XC6503D with ON/OFF function

XC6503①②③④⑤⑥-⑦^(*)1)

DESIGNATOR	ITEM	SYMBOL	DESCRIPTION
①	Type of Regulator ^(*)2)	D	CE Active High, with CE Pull-down, C _L discharge
②③	Output Voltage ^(*)3)	12~50	ex.) ②=2, ③=8 → 2.8V
④	Output Accuracy	1	±0.02V (1.2~1.9V)、±1% (2.0~5.0V)
⑤⑥-⑦	Packages (Order Unit)	GR-G	USP-4 (3,000/Reel)
		MR-G	SOT-25 (3,000/Reel)
		PR-G	SOT-89-5 (1,000/Reel)

^(*)1) The "-G" suffix denotes Halogen and Antimony free as well as being fully EU RoHS compliant.

^(*)2) For without CE Pull-down or without C_L discharge function, please contact your local Torex sales office or representative.

^(*)3) For the output voltage in 0.05V increments, please contact your local Torex sales office or representative.

● Ordering Information XC6503P 3-Terminal regulator

XC6503①②③④⑤⑥-⑦^(*)1)

DESIGNATOR	ITEM	SYMBOL	DESCRIPTION
①	Type of Regulator	P	3-Terminal regulator, without CE pin
②③	Output Voltage ^(*)2)	12~50	ex.) ②=2, ③=8 → 2.8V
④	Output Accuracy	1	±0.02V (1.2~1.9V)、±1% (2.0~5.0V)
⑤⑥-⑦	Packages (Order Unit)	PR-G	SOT-89 (1,000/Reel)

^(*)1) The "-G" suffix denotes Halogen and Antimony free as well as being fully RoHS compliant.

^(*)2) For the output voltage in 0.05V increments, please contact your local Torex sales office or representative.

■ BLOCK DIAGRAMS

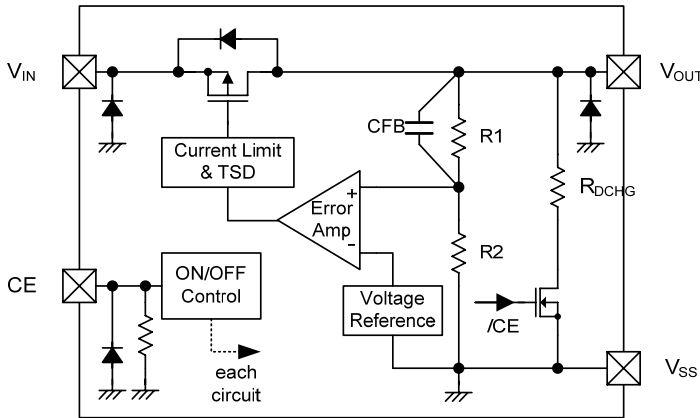

XC6503D Series

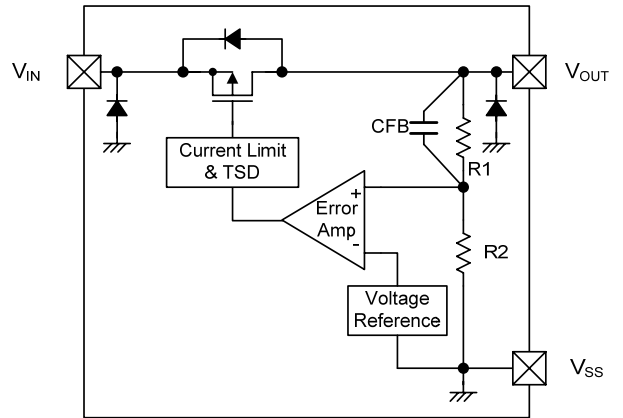

XC6503P Series

* Diodes inside the circuits are ESD protection diodes and parasitic diodes.

■ ABSOLUTE MAXIMUM RATINGS

Ta=25°C

PARAMETER	SYMBOL	RATINGS	UNITS	
Input Voltage	V _{IN}	V _{SS} -0.3~V _{SS} +6.5	V	
Output Current	I _{OUT}	850 ^(*1)	mA	
Output Voltage	V _{OUT}	V _{SS} -0.3~V _{IN} +0.3 ≤ V _{SS} +6.5	V	
CE Input Voltage	V _{CE}	V _{SS} -0.3~V _{SS} +6.5	V	
Power Dissipation	USP-4	Pd	120	mW
	SOT-25		250	
	SOT-89-5		500	
	SOT-89		500	
Power Dissipation ^(*2) (PCB mounted)	USP-4	Pd	1000	mW
	SOT-25		600	
	SOT-89-5		1300	
	SOT-89		1000	
Operating Ambient Temperature	T _{opr}	-40~+85	°C	
Storage Temperature	T _{stg}	-55~+125	°C	

(*1) Pd > (V_{IN}-V_{OUT}) × I_{OUT}

(*2) The power dissipation measured with the test board condition is listed as reference data. Please refer to page 21~24 for details.

ELECTRICAL CHARACTERISTICS

●XC6503D Type

Ta=25°C

PARAMETER	SYMBOL	CONDITIONS	MIN.	TYP.	MAX.	UNITS	CIRCUITS
Output Voltage	V _{OUT(E)} ^(*2)	2.0V > V _{OUT(T)} ^(*3) , V _{CE} =V _{IN} , I _{OUT} =10mA	-0.02 ^(*4)	V _{OUT(T)}	+0.02 ^(*4)	V	①
		2.0V ≤ V _{OUT(T)} , V _{CE} =V _{IN} , I _{OUT} =10mA	×0.99 ^(*4)		×1.01 ^(*4)		
Maximum Output Current	I _{OUTMAX}	V _{CE} =V _{IN}	500	-	-	mA	①
Load Regulation	ΔV _{OUT}	V _{CE} =V _{IN} , 0.1mA ≤ I _{OUT} ≤ 300mA	-	20	50	mV	①
Dropout Voltage ^(*5)	V _{dif}	V _{CE} =V _{IN} , I _{OUT} =300mA	-	E-1 ^(*6)		mV	①
Supply Current	I _{SS}	V _{IN} =V _{CE} =6.0V, I _{OUT} =0mA	-	15	30	μA	②
Stand-by Current	I _{STB}	V _{IN} =6.0V, V _{CE} =V _{SS}	-	0.01	0.1	μA	②
Line Regulation	ΔV _{OUT} / (ΔV _{IN} ·V _{OUT})	V _{OUT(T)} +0.5V ≤ V _{IN} ≤ 6.0V, V _{CE} =V _{IN} , I _{OUT} =30mA	-	E-2 ^(*9)		%/V	①
Input Voltage	V _{IN}		1.7	-	6.0	V	①
Output Voltage Temperature Characteristics	ΔV _{OUT} / (ΔTopr·V _{OUT})	V _{CE} =V _{IN} , I _{OUT} =30mA -40°C ≤ Topr ≤ 85°C	-	±30	-	ppm/°C	①
Power Supply Rejection Ratio	PSRR	V _{OUT(T)} ≤ 4.75V V _{IN} = [V _{OUT(T)} + 1.0]V _{DC} + 0.5V _{p-pAC} V _{CE} =V _{IN} , I _{OUT} =30mA, f=1kHz V _{OUT(T)} ≥ 4.80V V _{IN} = 5.75V _{DC} + 0.5V _{p-pAC} V _{CE} =V _{IN} , I _{OUT} =30mA, f=1kHz	-	55	-	dB	③
Current Limit	I _{LIM}	V _{CE} =V _{IN}	510	630	750	mA	①
Short-circuit Current	I _{SHORT}	V _{CE} =V _{IN} Short V _{OUT} to V _{SS} level	-	120	210	mA	①
CE High Level Voltage	V _{CEH}		1.0	-	6.0	V	①
CE Low Level Voltage	V _{CEL}		V _{SS}	-	0.3	V	①
CE High Level Current	I _{CEH}	V _{IN} =V _{CE} =6.0V	3.5	6	10	μA	①
CE Low Level Current	I _{CEL}	V _{CE} =V _{SS}	-0.1	-	0.1	μA	①
C _L Discharge Resistance ^(*10)	R _{DCHG}	V _{IN} =6.0V, V _{OUT} =5.0V, V _{CE} =V _{SS}	300	430	500	Ω	①
Thermal Shutdown Detect Temperature	T _{TSD}	Junction Temperature	-	150	-	°C	-
Thermal Shutdown Release Temperature	T _{TSR}	Junction Temperature	-	125	-	°C	-
Thermal Shutdown Hysteresis Width	T _{HYS}	T _{TSD} -T _{TSR}	-	25	-	°C	-

NOTE:

(*1) Unless otherwise stated regarding input voltage conditions, V_{IN}=V_{OUT(T)}^(*3)+1.0V.

(*2) V_{OUT(E)}: Effective output voltage

(i.e. the output voltage when "V_{OUT(T)}+1.0V" is provided at the V_{IN} pin while maintaining a certain I_{OUT} value.)

(*3) V_{OUT(T)}: Nominal output voltage

(*4) Characteristics of the actual V_{OUT(E)} by setting output voltage is shown in the voltage chart.

(*5) V_{dif}=V_{IN1}^(*7)-V_{OUT1}^(*6)

(*6) V_{OUT1} is a voltage equal to 98% of the output voltage whenever an amply stabilized I_{OUT} {V_{OUT(T)}+1.0V} is input

(*7) V_{IN1} is an input voltage when V_{OUT1} appears at the V_{OUT} pin while the input voltage is gradually decreased.

(*8) E-1:DROPOUT VOLTAGE (Refer to Voltage Chart.)

(*9) E-2:LINE REGULATION (Refer to Voltage Chart.)

(*10) This function is built in the XC6503B/D series only.

The XC6503A/C series discharges by only R1+ R2 resistors as shown in the block diagrams.

ELECTRICAL CHARACTERISTICS (Continued)

●XC6503P Type

Ta=25°C

PARAMETER	SYMBOL	CONDITIONS	MIN.	TYP.	MAX.	UNITS	CIRCUITS
Output Voltage	V _{OUT(E)} ^(*2)	2.0V > V _{OUT(T)} ^(*3) , I _{OUT} =10mA	-0.02 ^(*4)	V _{OUT(T)}	+0.02 ^(*4)	V	①
		2.0V ≤ V _{OUT(T)} , I _{OUT} =10mA	×0.99 ^(*4)		×1.01 ^(*4)		
Maximum Output Current	I _{OUTMAX}		500	-	-	mA	①
Load Regulation	ΔV _{OUT}	0.1mA ≤ I _{OUT} ≤ 300mA	-	20	50	mV	①
Dropout Voltage ^(*5)	V _{dif}	I _{OUT} =300mA	-	E-1 ^(*8)		mV	①
Supply Current	I _{SS}	V _{IN} =6.0V, I _{OUT} =0mA	-	15	30	μA	②
Line Regulation	$\frac{\Delta V_{OUT}}{(\Delta V_{IN} \cdot V_{OUT})}$	V _{OUT(T)} +0.5V ≤ V _{IN} ≤ 6.0V, I _{OUT} =30mA	-	E-2 ^(*9)		%/V	①
Input Voltage	V _{IN}		1.7	-	6.0	V	①
Output Voltage Temperature Characteristics	$\frac{\Delta V_{OUT}}{(\Delta T_{opr} \cdot V_{OUT})}$	I _{OUT} =30mA -40°C ≤ T _{opr} ≤ 85°C	-	±30	-	ppm/°C	①
Power Supply Rejection Ratio	PSRR	V _{OUT(T)} ≤ 4.75V V _{IN} = {V _{OUT(T)} +1.0}V _{DC} +0.5V _{p-pAC} I _{OUT} =30mA, f=1kHz V _{OUT(T)} ≥ 4.80V V _{IN} =5.75V _{DC} +0.5V _{p-pAC} I _{OUT} =30mA, f=1kHz	-	55	-	dB	③
Current Limit	I _{LIM}		510	630	750	mA	①
Short-circuit Current	I _{SHORT}	Short V _{OUT} to V _{SS} level	-	120	210	mA	①
Thermal Shutdown Detect Temperature	T _{TSD}	Junction Temperature	-	150	-	°C	-
Thermal Shutdown Release Temperature	T _{TSR}	Junction Temperature	-	125	-	°C	-
Thermal Shutdown Hysteresis Width	T _{HYS}	T _{TSD} -T _{TSR}	-	25	-	°C	-

NOTE:

(*1) Unless otherwise stated regarding input voltage conditions, V_{IN}=V_{OUT(T)}^(*3)+1.0V.

(*2) V_{OUT(E)}: Effective output voltage

(i.e. the output voltage when "V_{OUT(T)}+1.0V" is provided at the V_{IN} pin while maintaining a certain I_{OUT} value.)

(*3) V_{OUT(T)}: Nominal output voltage

(*4) Characteristics of the actual V_{OUT(E)} by setting output voltage is shown in the voltage chart.

(*5) V_{dif}=V_{IN1}^(*7)-V_{OUT1}^(*6)

(*6) V_{OUT1} is a voltage equal to 98% of the output voltage whenever an amply stabilized I_{OUT} {V_{OUT(T)}+1.0V} is input

(*7) V_{IN1} is an input voltage when V_{OUT1} appears at the V_{OUT} pin while the input voltage is gradually decreased.

(*8) E-1:DROPOUT VOLTAGE (Refer to Voltage Chart.)

(*9) E-2:LINE REGULATION (Refer to Voltage Chart.)

■ ELECTRICAL CHARACTERISTICS (Continued)

● Voltage Chart

Ta=25°C

NOMINAL VOLTAGE (V)	E-0		E-1		E-2		NOMINAL VOLTAGE (V)	E-0		E-1		E-2	
	OUTPUT VOLTAGE (V)		DROPOUT VOLTAGE (mV)		LINE REGULATION (%/V)			OUTPUT VOLTAGE (V)		DROPOUT VOLTAGE (mV)		LINE REGULATION (%/V)	
	V _{OUT(E)}		V _{dif}		$\frac{\Delta V_{OUT}}{(\Delta V_{IN} \cdot V_{OUT})}$			V _{OUT(E)}		V _{dif}		$\frac{\Delta V_{OUT}}{(\Delta V_{IN} \cdot V_{OUT})}$	
V _{OUT(T)}	MIN.	MAX.	TYP.	MAX.	TYP.	MAX.	V _{OUT(T)}	MIN.	MAX.	TYP.	MAX.	TYP.	MAX.
1.200	1.1800	1.2200	555	660	0.1	0.25	3.150	3.1185	3.1815	190	250	0.1	0.2
1.250	1.2300	1.2700	↑	↑	↑	↑	3.200	3.1680	3.2320	170	230	↑	↑
1.300	1.2800	1.3200	↑	↑	↑	0.2	3.250	3.2175	3.2825	↑	↑	↑	↑
1.350	1.3300	1.3700	↑	↑	↑	↑	3.300	3.2670	3.3330	↑	↑	↑	↑
1.400	1.3800	1.4200	440	560	↑	↑	3.350	3.3165	3.3835	↑	↑	↑	↑
1.450	1.4300	1.4700	↑	↑	↑	↑	3.400	3.3660	3.4340	↑	↑	↑	↑
1.500	1.4800	1.5200	↑	↑	↑	↑	3.450	3.4155	3.4845	↑	↑	↑	↑
1.550	1.5300	1.5700	↑	↑	↑	↑	3.500	3.4650	3.5350	↑	↑	↑	↑
1.600	1.5800	1.6200	360	450	↑	↑	3.550	3.5145	3.5855	↑	↑	↑	↑
1.650	1.6300	1.6700	↑	↑	↑	↑	3.600	3.5640	3.6360	155	210	↑	↑
1.700	1.6800	1.7200	↑	↑	↑	↑	3.650	3.6135	3.6865	↑	↑	↑	↑
1.750	1.7300	1.7700	↑	↑	↑	↑	3.700	3.6630	3.7370	↑	↑	↑	↑
1.800	1.7800	1.8200	300	390	↑	↑	3.750	3.7125	3.7875	↑	↑	↑	↑
1.850	1.8300	1.8700	↑	↑	↑	↑	3.800	3.7620	3.8380	↑	↑	↑	↑
1.900	1.8800	1.9200	↑	↑	↑	↑	3.850	3.8115	3.8885	↑	↑	↑	↑
1.950	1.9300	1.9700	↑	↑	↑	↑	3.900	3.8610	3.9390	↑	↑	↑	↑
2.000	1.9800	2.0200	265	330	↑	↑	3.950	3.9105	3.9895	↑	↑	↑	↑
2.050	2.0295	2.0705	↑	↑	↑	↑	4.000	3.9600	4.0400	↑	↑	↑	↑
2.100	2.0790	2.1210	↑	↑	↑	↑	4.050	4.0095	4.0905	↑	↑	↑	↑
2.150	2.1285	2.1715	↑	↑	↑	↑	4.100	4.0590	4.1410	↑	↑	↑	↑
2.200	2.1780	2.2220	240	310	↑	↑	4.150	4.1085	4.1915	↑	↑	↑	↑
2.250	2.2275	2.2725	↑	↑	↑	↑	4.200	4.1580	4.2420	140	195	↑	↑
2.300	2.2770	2.3230	↑	↑	↑	↑	4.250	4.2075	4.2925	↑	↑	↑	↑
2.350	2.3265	2.3735	↑	↑	↑	↑	4.300	4.2570	4.3430	↑	↑	↑	↑
2.400	2.3760	2.4240	↑	↑	↑	↑	4.350	4.3065	4.3935	↑	↑	↑	↑
2.450	2.4255	2.4745	↑	↑	↑	↑	4.400	4.3560	4.4440	↑	↑	↑	↑
2.500	2.4750	2.5250	210	270	↑	↑	4.450	4.4055	4.4945	↑	↑	↑	↑
2.550	2.5245	2.5755	↑	↑	↑	↑	4.500	4.4550	4.5450	↑	↑	↑	↑
2.600	2.5740	2.6260	↑	↑	↑	↑	4.550	4.5045	4.5955	↑	↑	↑	↑
2.650	2.6235	2.6765	↑	↑	↑	↑	4.600	4.5540	4.6460	↑	↑	↑	↑
2.700	2.6730	2.7270	↑	↑	↑	↑	4.650	4.6035	4.6965	↑	↑	↑	↑
2.750	2.7225	2.7775	↑	↑	↑	↑	4.700	4.6530	4.7470	↑	↑	↑	↑
2.800	2.7720	2.8280	190	250	↑	↑	4.750	4.7025	4.7975	↑	↑	↑	↑
2.850	2.8215	2.8785	↑	↑	↑	↑	4.800	4.7520	4.8480	↑	↑	↑	↑
2.900	2.8710	2.9290	↑	↑	↑	↑	4.850	4.8015	4.8985	↑	↑	↑	↑
2.950	2.9205	2.9795	↑	↑	↑	↑	4.900	4.8510	4.9490	↑	↑	↑	↑
3.000	2.9700	3.0300	↑	↑	↑	↑	4.950	4.9005	4.9995	↑	↑	↑	↑
3.050	3.0195	3.0805	↑	↑	↑	↑	5.000	4.9500	5.0500	↑	↑	↑	↑
3.100	3.0690	3.1310	↑	↑	↑	↑							

OPERATIONAL EXPLANATION

The voltage divided by resistors R1 and R2 is compared with the internal reference voltage by the error amplifier. The P-channel MOSFET which is connected to the V_{OUT} pin is then driven by the subsequent output signal. The output voltage at the V_{OUT} pin is controlled and stabilized by a system of negative feedback. The current limit circuit and short circuit protection operate in relation to the level of output current and heat dissipation. Current limit circuit and short protection circuit operate with output current and thermal shutdown circuit will operate with heating. Further, the IC's internal circuitry can be shutdown via the CE pin signal.

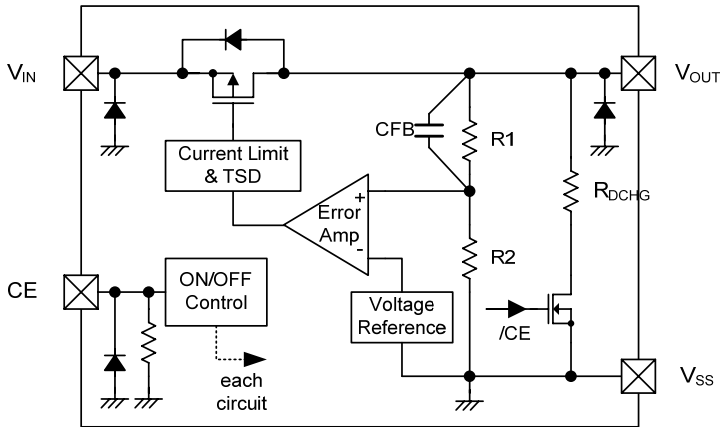

XC6503 Series D Type

<C_L Auto-Discharge Function>

XC6503D can quickly discharge the electric charge at the output capacitor (C_L), when a low signal to the CE pin, which enables a whole IC circuit put into OFF state, is inputted via the N-channel transistor located between the V_{OUT} pin and the V_{SS} pin (cf. BLOCK DIAGRAM). The C_L discharge resistance is set to 430 Ω when V_{IN} is 6.0V (TYP.) and V_{OUT} is 5.0V (TYP.). Moreover, discharge time of the output capacitor (C_L) is set by the C_L auto-discharge resistance (R_{DCHG}) and the output capacitor (C_L). By setting time constant of a C_L auto-discharge resistance value (R_{DCHG}) and an output capacitor value (C_L) as τ ($\tau = C \times R$), the output voltage after discharge via the N-channel transistor is calculated by the following formula.

$$V = V_{OUT(E)} \times e^{-t/\tau}, \text{ or } t = \tau \ln(V_{OUT(E)} / V)$$

(V : Output voltage after discharge, V_{OUT(E)} : Initial Output voltage, t: Discharge time,
 τ : C_L auto-discharge resistance R_{DCHG} × C_L Output capacitance)

<Current Limiter, Short-Circuit Protection>

The protection circuit operates as a combination of an output current limiter and fold-back short circuit protection. When load current reaches the current limit level, the output voltage drops. As a result, the load current starts to reduce with showing fold-back curve. The output current finally falls at the level of 120mA when the V_{OUT} pin is short-circuited.

<Thermal Shutdown>

When the junction temperature of the built-in driver transistor reaches the temperature limit, the thermal shutdown circuit operates and the driver transistor will be set to OFF. The IC resumes its operation when the thermal shutdown function is released and the IC's operation is automatically restored because the junction temperature drops to the level of the thermal shutdown release voltage.

<CE Pin>

The IC's internal circuitry can be shutdown via the signal from the CE pin with the XC6503D series. In shutdown mode, output at the V_{OUT} pin will be pulled down to the V_{SS} level via R1, R2 and C_L auto-discharge resistance R_{DCHG}. Please note the XC6503P does not have the CE pin.

The XC6503D has a pulled down resistor at the CE pin in order to avoid an unstable operation with the CE pin open (the CE pin is left open, operation will be stopped). However, the CE pin input current will increase slightly through the pulled down resistor when operating. If the correct output voltage is applied to the CE pin, the logic is fixed and the IC will operate normally. However, if the medium voltage is input, supply current may increase as a result of an internal through current.

■ NOTES ON USE

1. For temporary, transitional voltage drop or voltage rising phenomenon, the IC is liable to malfunction should the ratings be exceeded.
2. The XC6503 series operates even if without attaching an output capacitor. However, when wiring impedance is high, operations may become unstable due to noise and/or phase lag depending on output current. Please wire the input capacitor (C_{IN}) and the output capacitor (C_L) as close to the IC as possible.
3. The XC6503 installs fold-back current limit circuits. When start-up, this fold-back load curve affects its start-up characteristics. The XC6503 having output current under 2.4V may not happen to start-up with the load conditions below. In these cases, sequence control should be taken for connecting a load after the start-up execution.

Load Condition for Start-up: $I_{OUT} \leq V_{OUT(T)}/4.8$

$V_{OUT(T)}$: Nominal Output Voltage

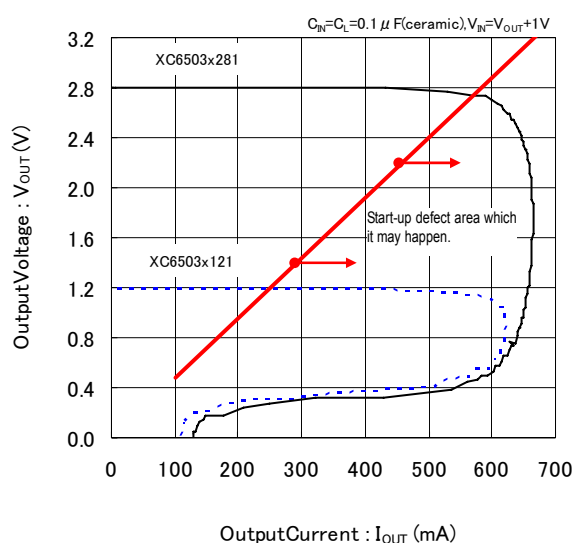

● CONDITION

NOMINAL VOLTAGE	LOAD CONDITION FOR START-UP
1.2V	$\leq 250\text{mA}$
1.5V	$\leq 312\text{mA}$
1.8V	$\leq 375\text{mA}$

4. Torex places an importance on improving our products and its reliability. However, by any possibility, we would request user fail-safe design and post-aging treatment on system or equipment.

TEST CIRCUITS

● Circuit ①

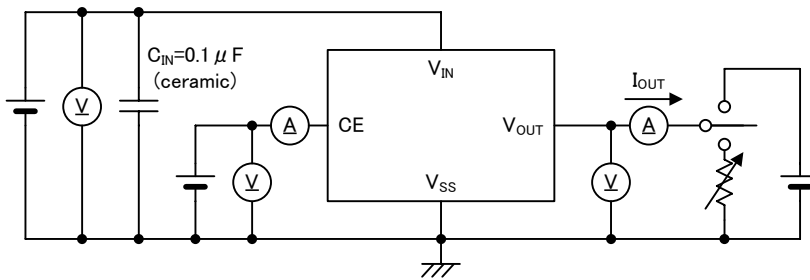

● Circuit ②

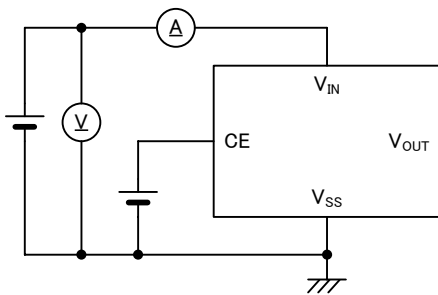

● Circuit ③

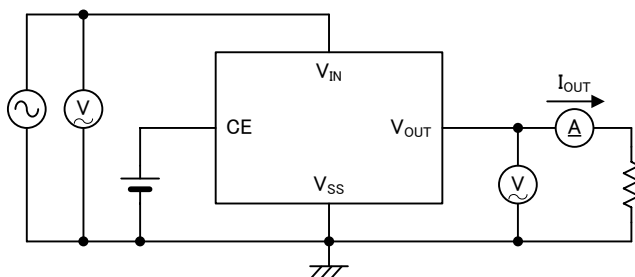

* For the XC6503P series, CE pin is connected to the V_{IN} internally.

TYPICAL PERFORMANCE CHARACTERISTICS

(1) OutputVoltage v.s. OutputCurrent

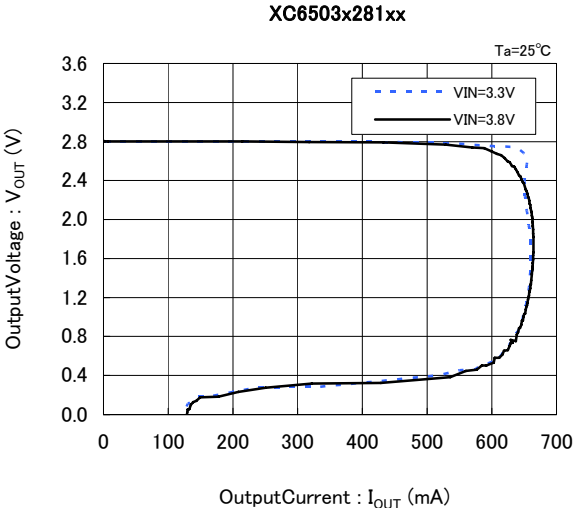
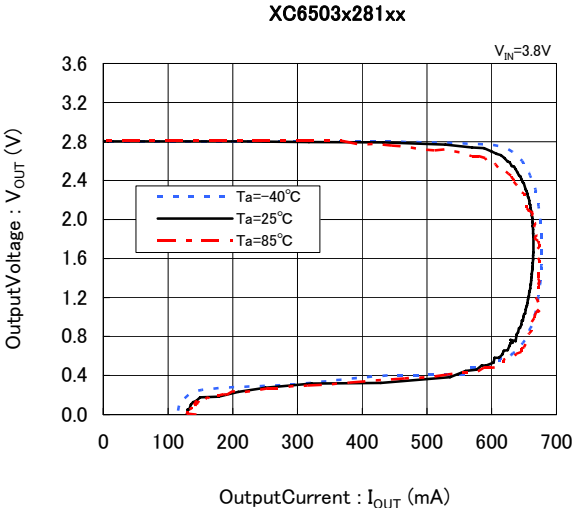
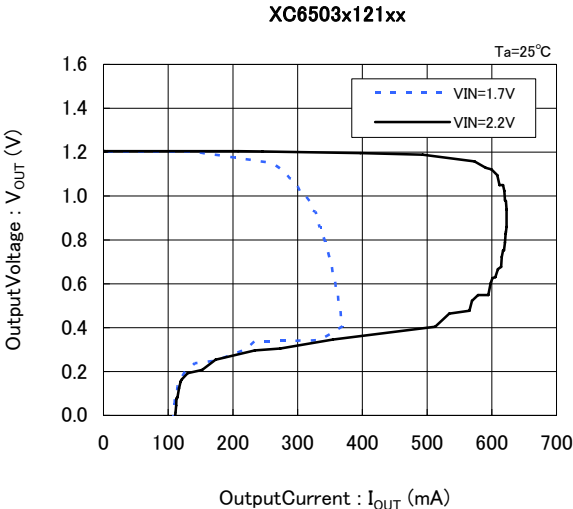
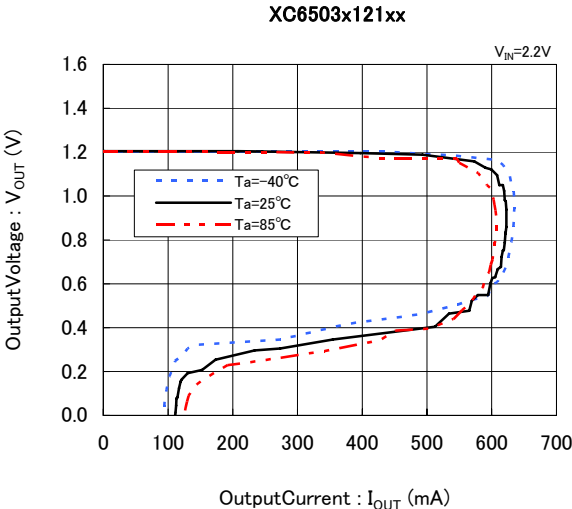

(2) OutputVoltage v.s. InputVoltage

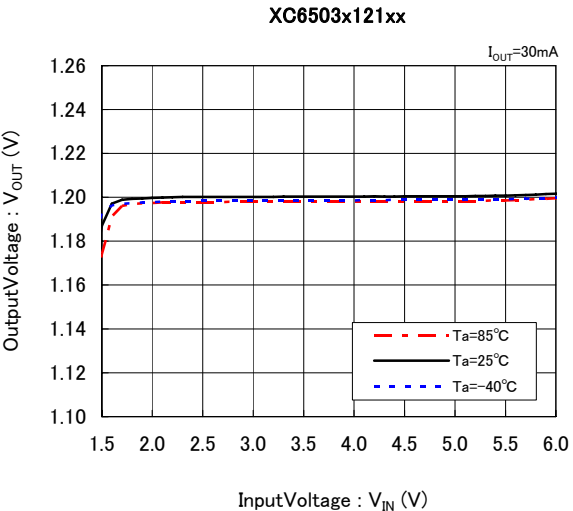
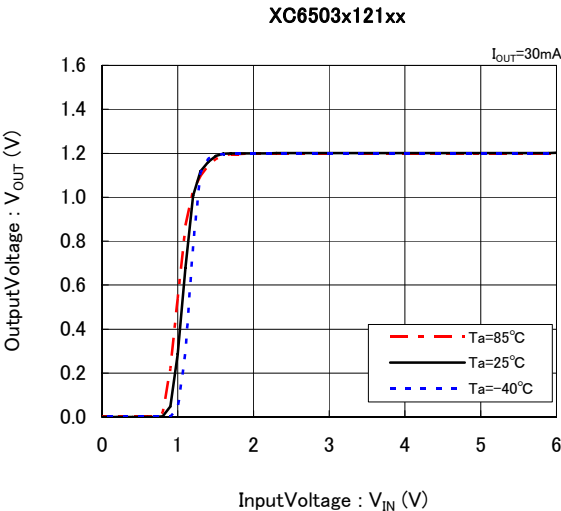

TYPICAL PERFORMANCE CHARACTERISTICS (Continued)

(2) OutputVoltage v.s. InputVoltage

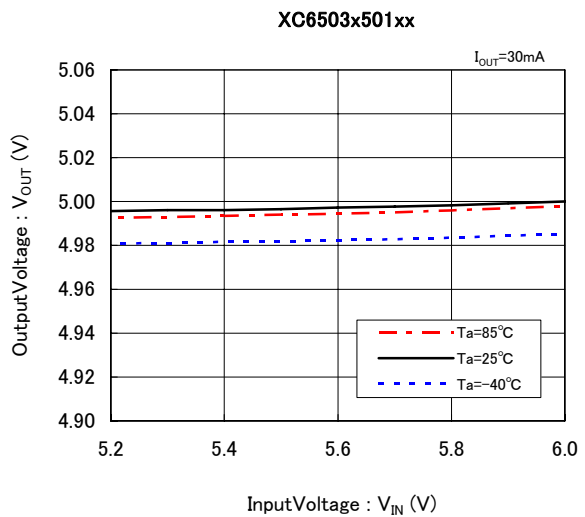
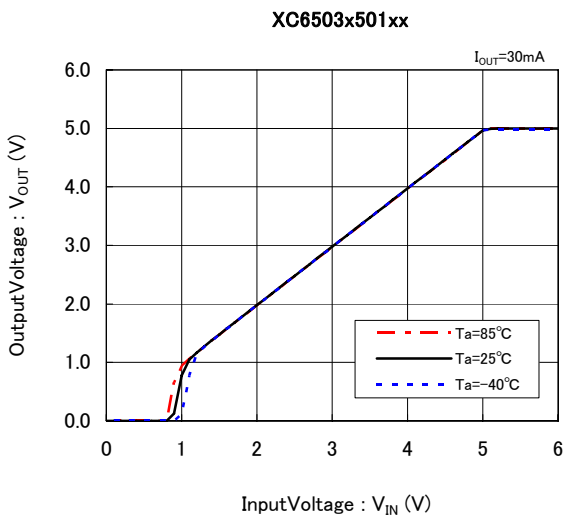
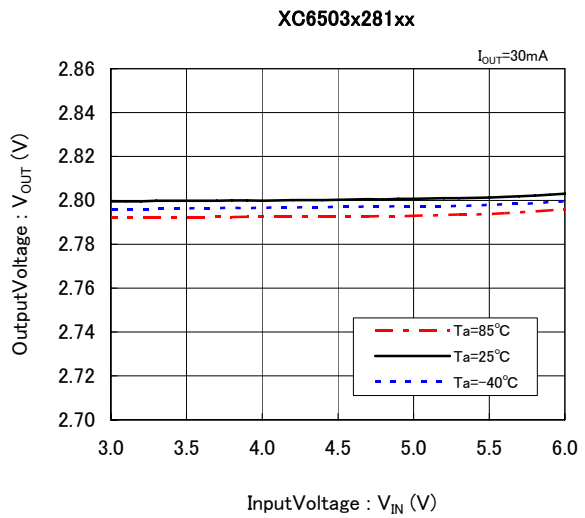
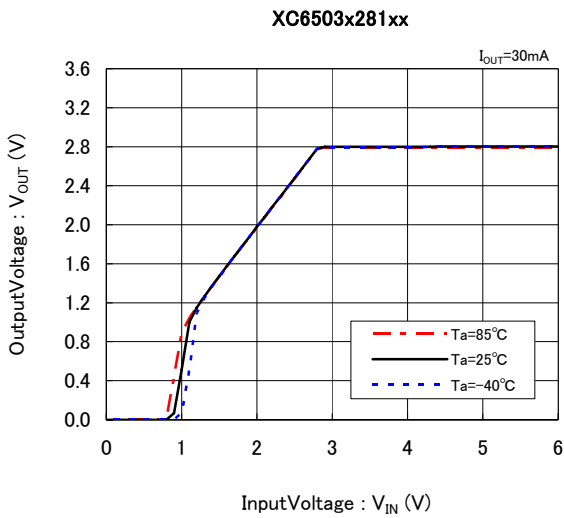

(3) DropoutVoltage v.s. OutputCurrent

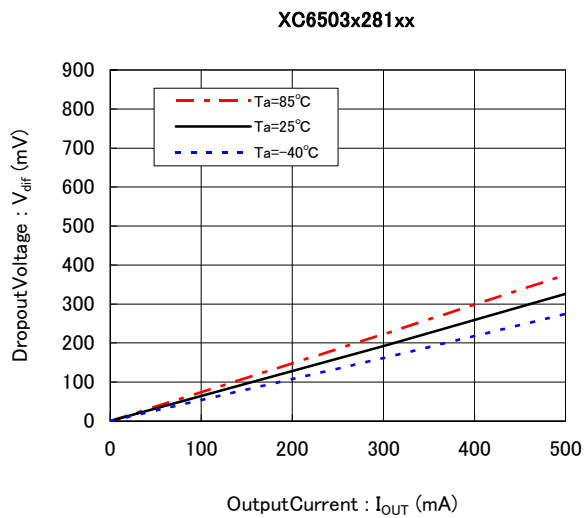
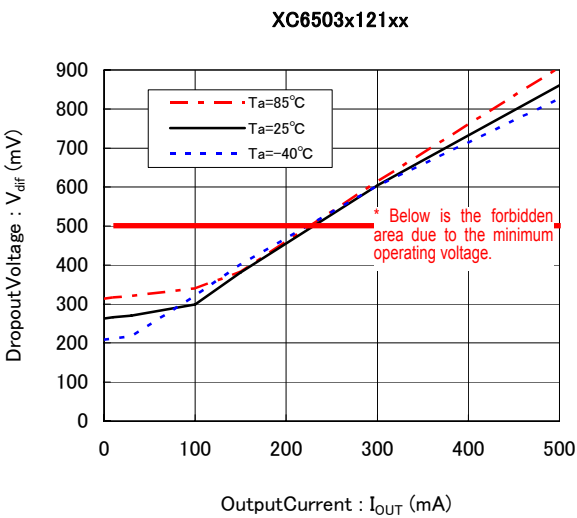

TYPICAL PERFORMANCE CHARACTERISTICS (Continued)

(3) DropoutVoltage v.s. OutputCurrent

XC6503x501xx

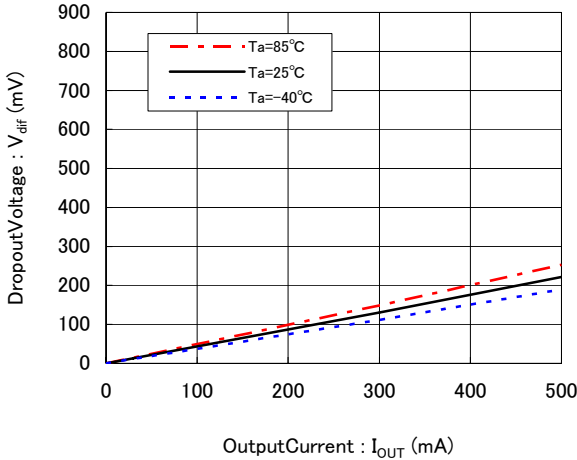

(4) SupplyCurrent v.s. InputVoltage

XC6503x121xx

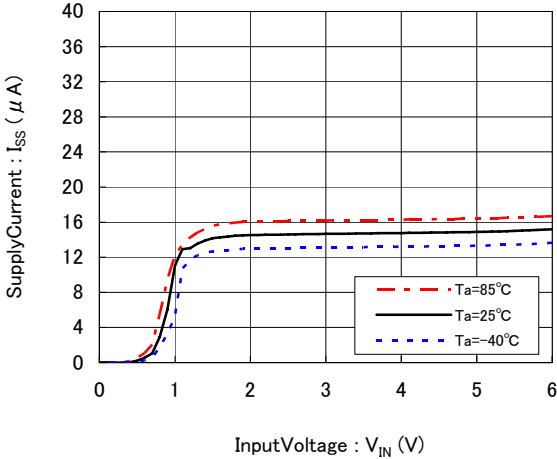

XC6503x281xx

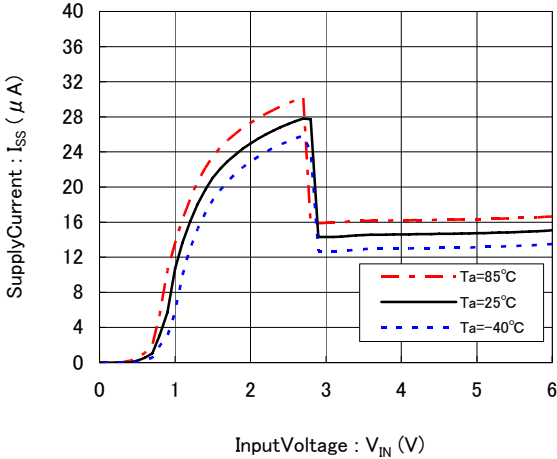

XC6503x501xx

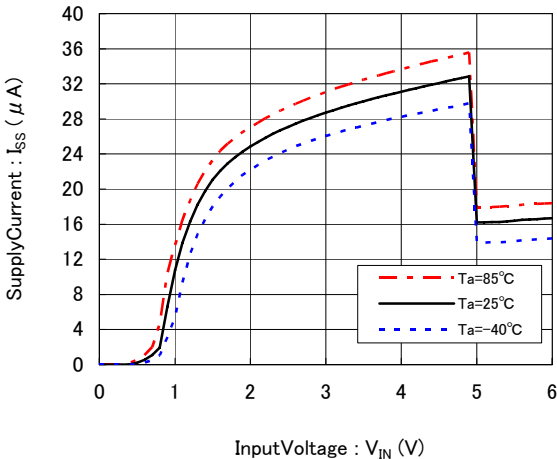

TYPICAL PERFORMANCE CHARACTERISTICS (Continued)

(5) Output Voltage v.s. Ambient Temperature

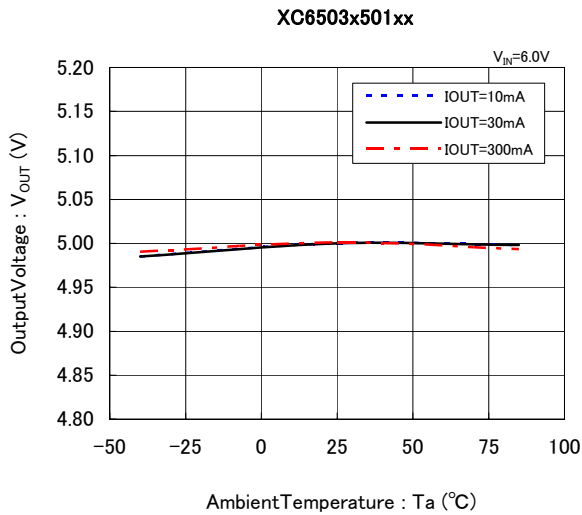
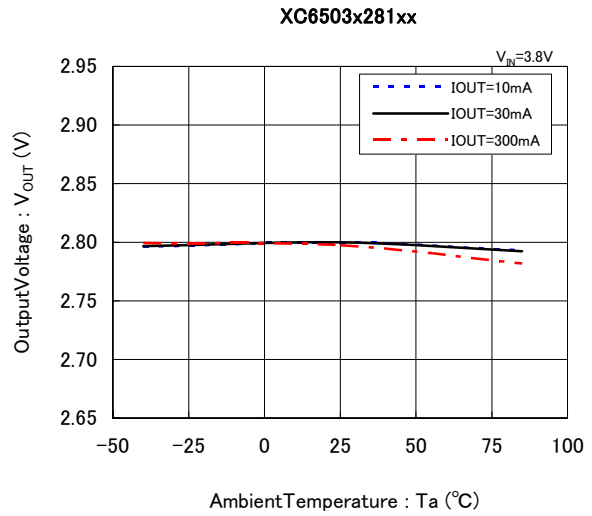
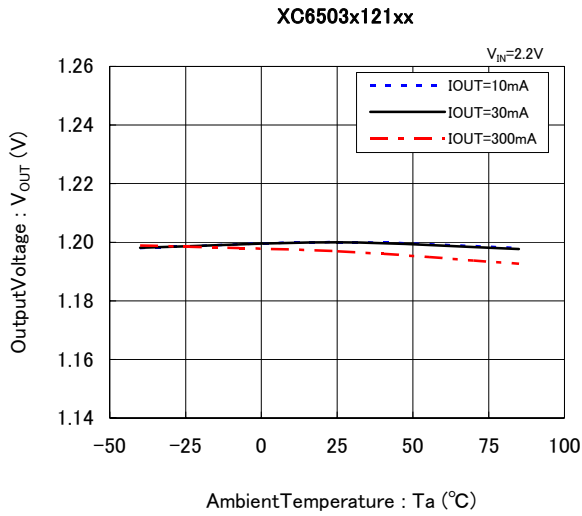

(6) Rising Response Time

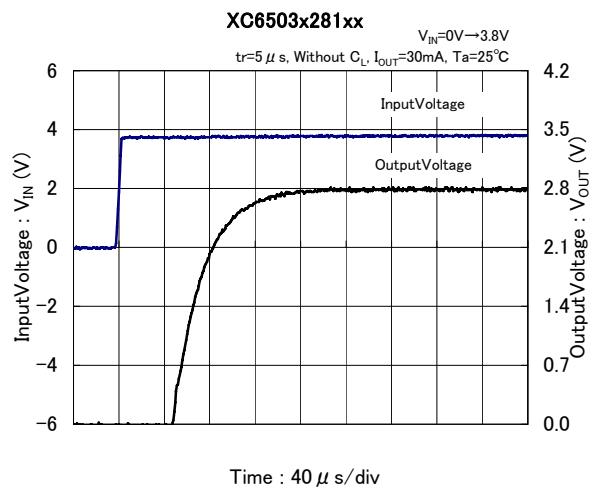
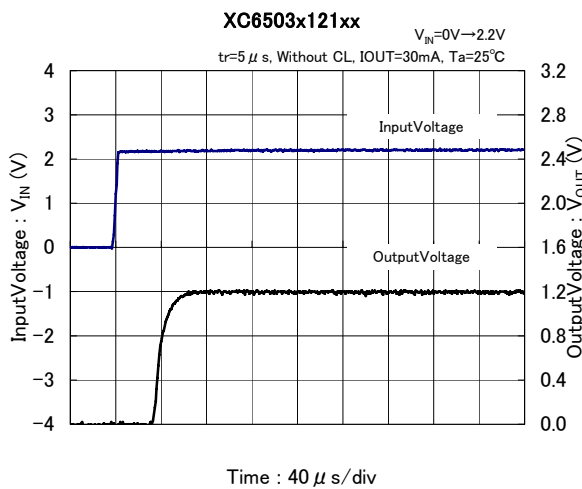

TYPICAL PERFORMANCE CHARACTERISTICS (Continued)

(6) Rising Respose Time

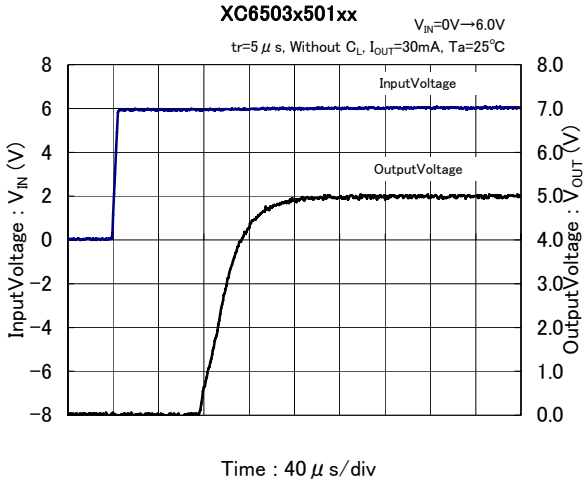

(7) Rush Current

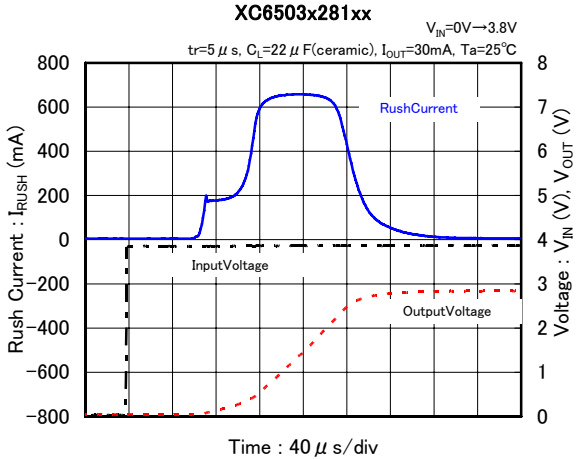
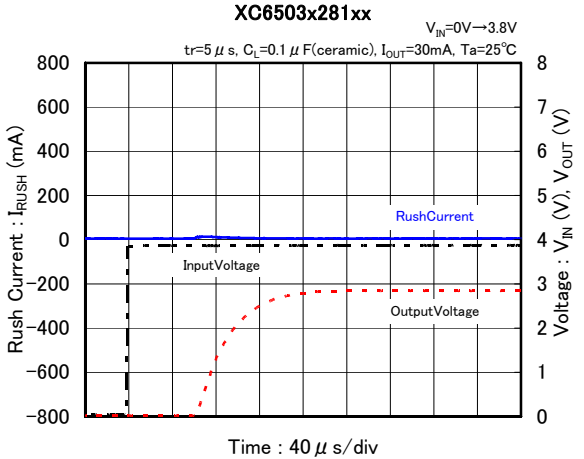

(8) CE Rising Respose Time

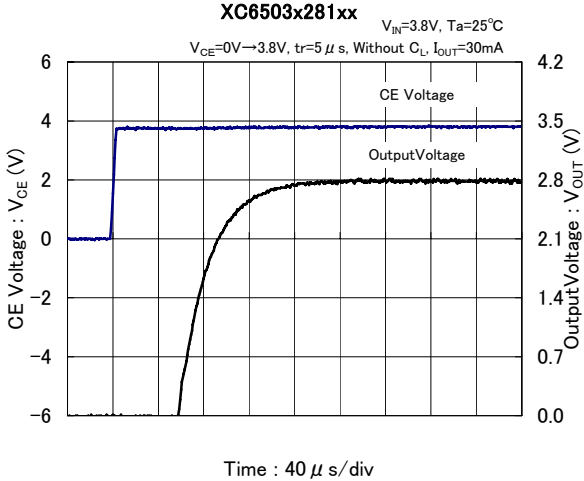
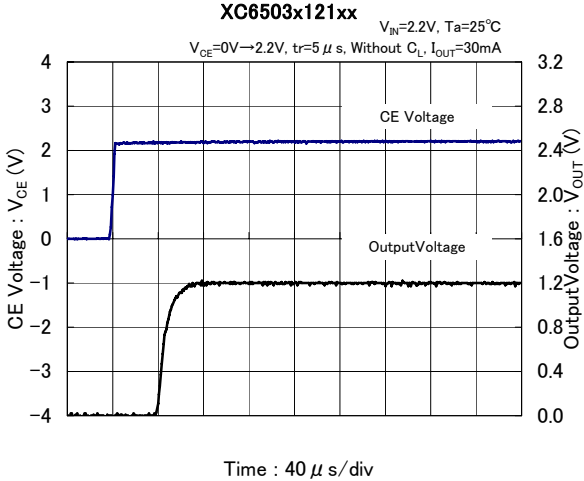

TYPICAL PERFORMANCE CHARACTERISTICS (Continued)

(8) CE Rising Respose Time

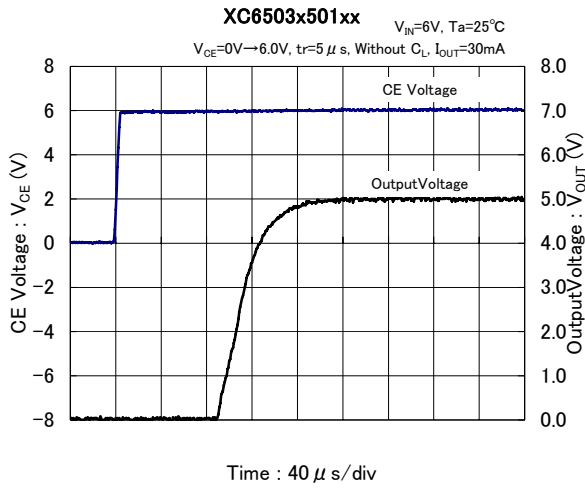

(9) Line transient response

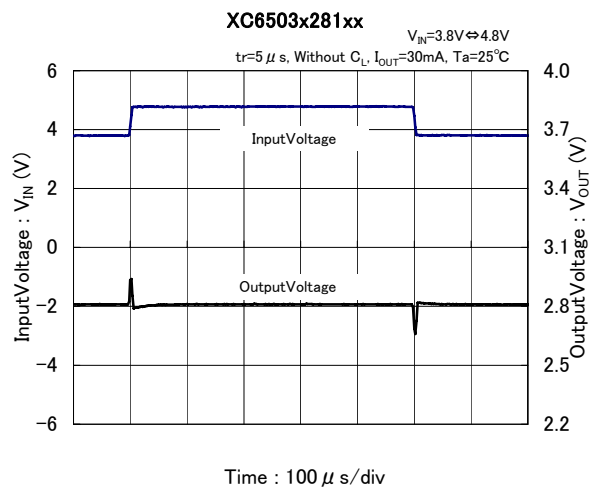
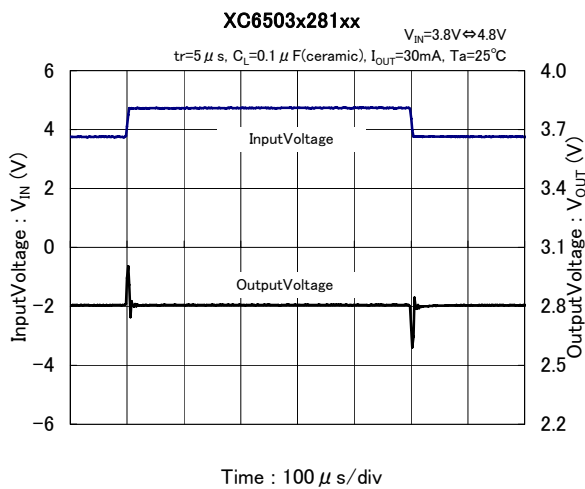
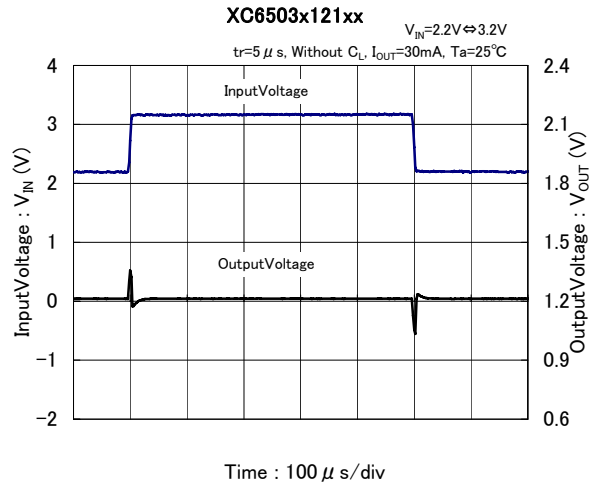
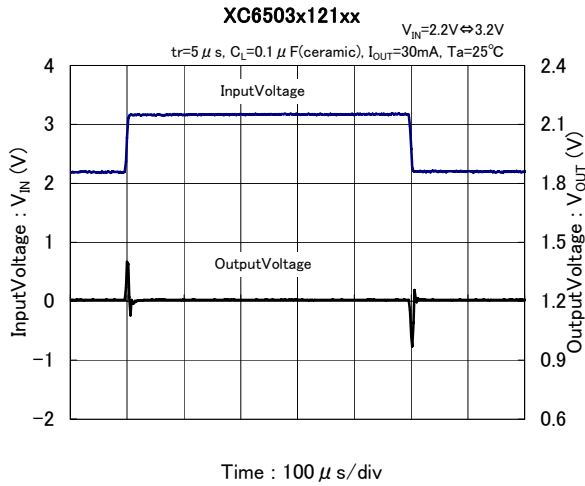

■ TYPICAL PERFORMANCE CHARACTERISTICS (Continued)

(9) Line transient response

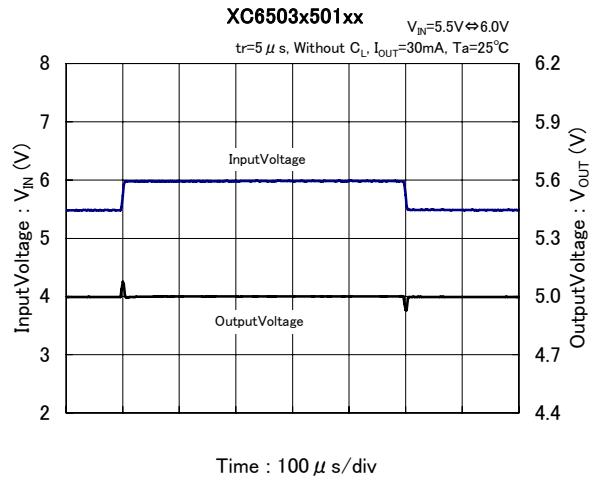
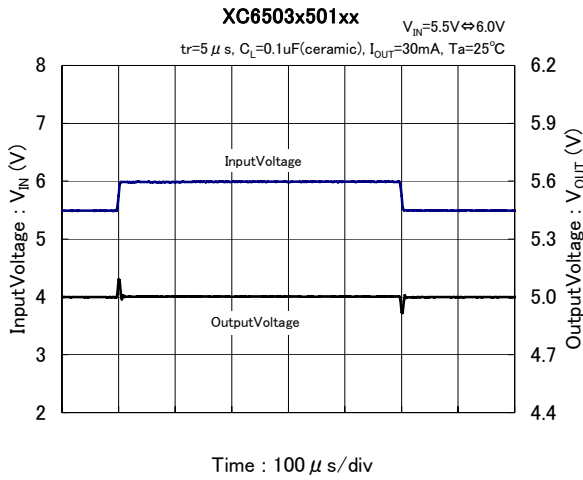

(10) Load transient response

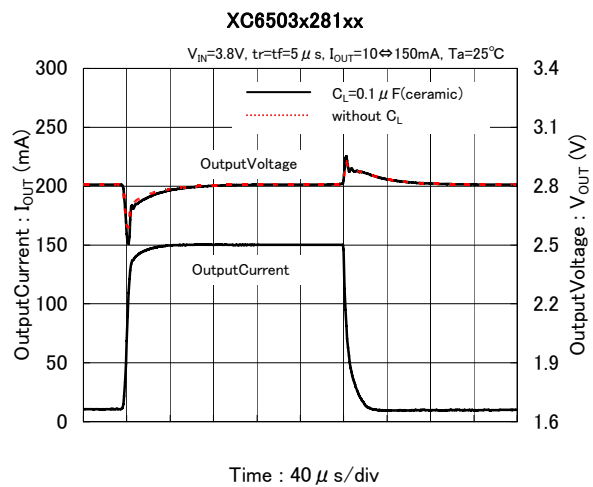
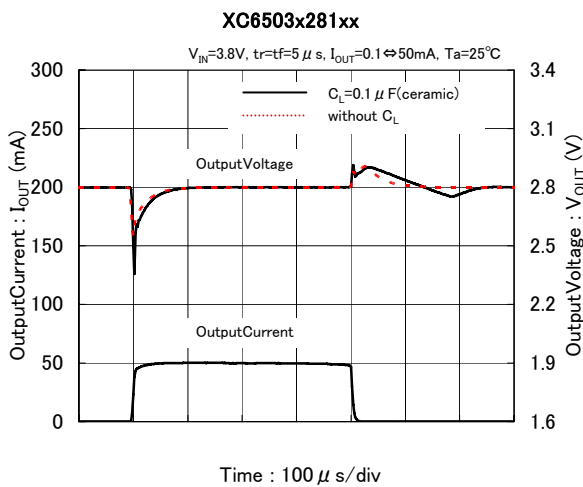
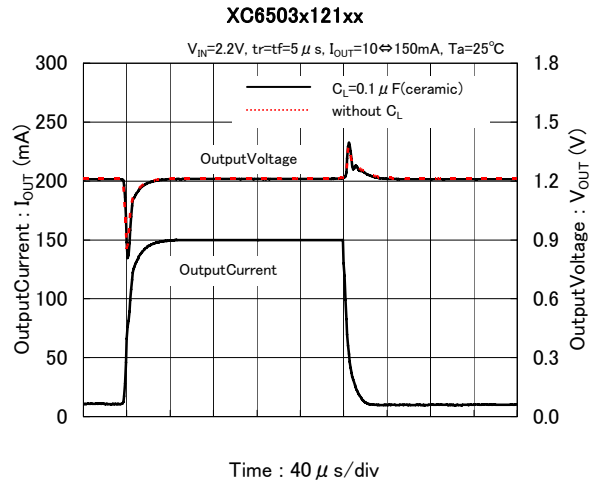
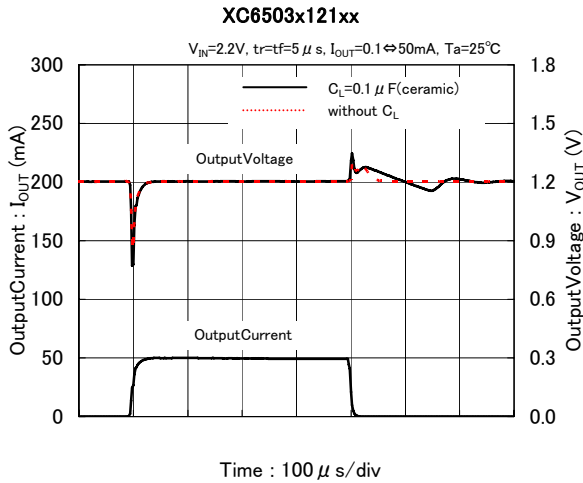

TYPICAL PERFORMANCE CHARACTERISTICS (Continued)

(10) Load transient response

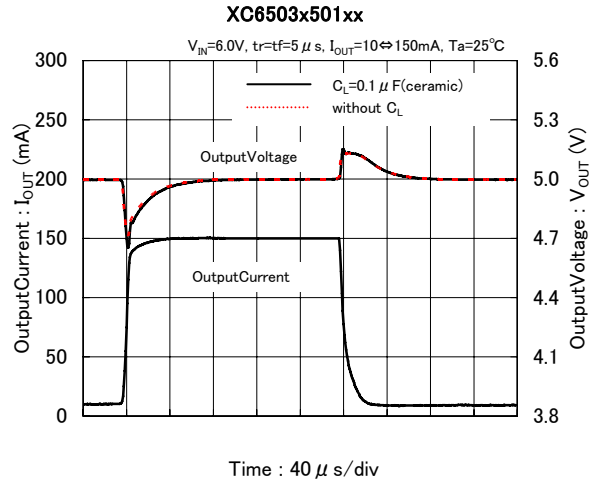
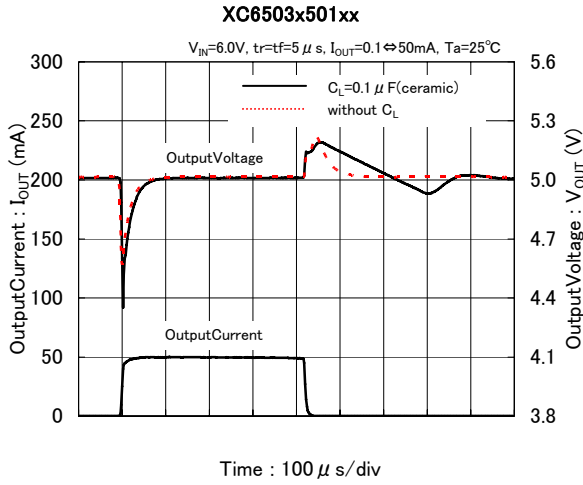

(11) Ripple Rejection Ratio

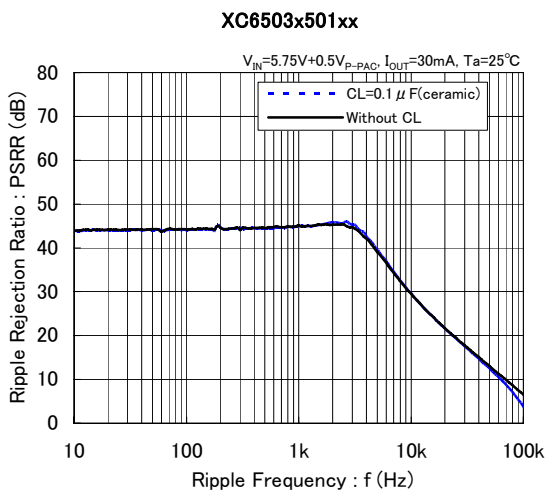
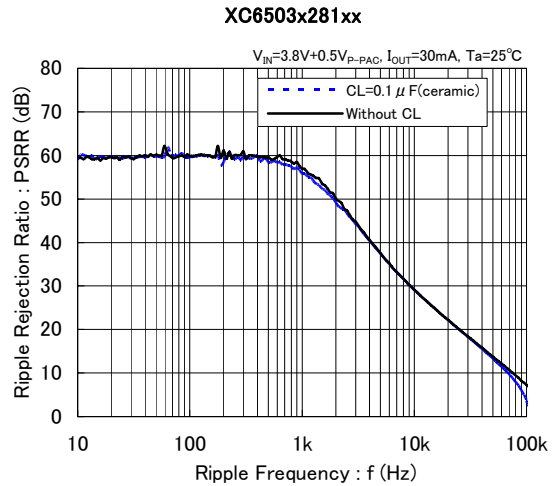
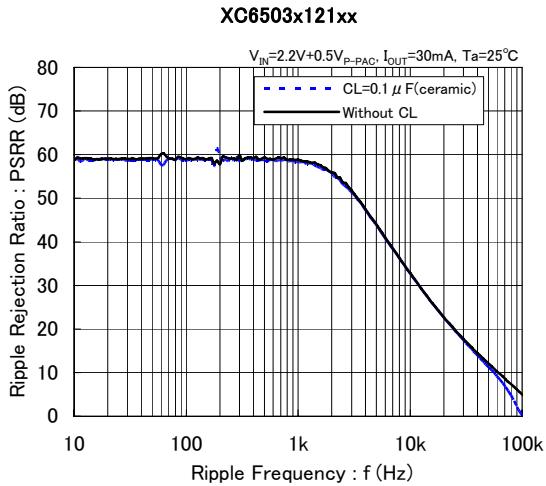

PACKAGING INFORMATION

● USP-4

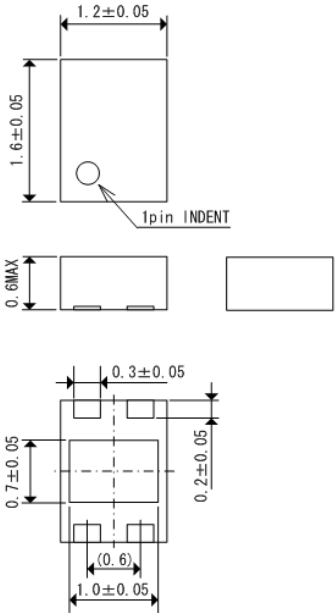

● SOT-25

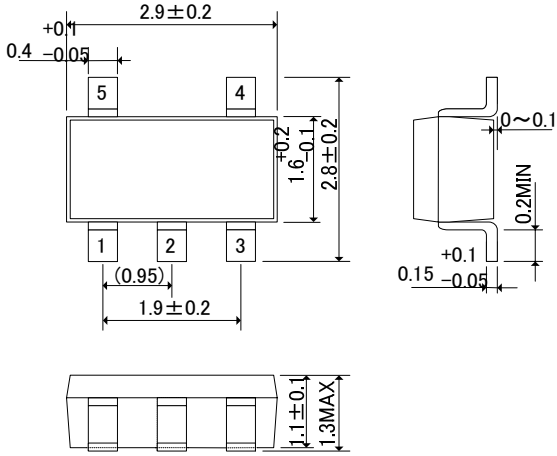

● SOT-89

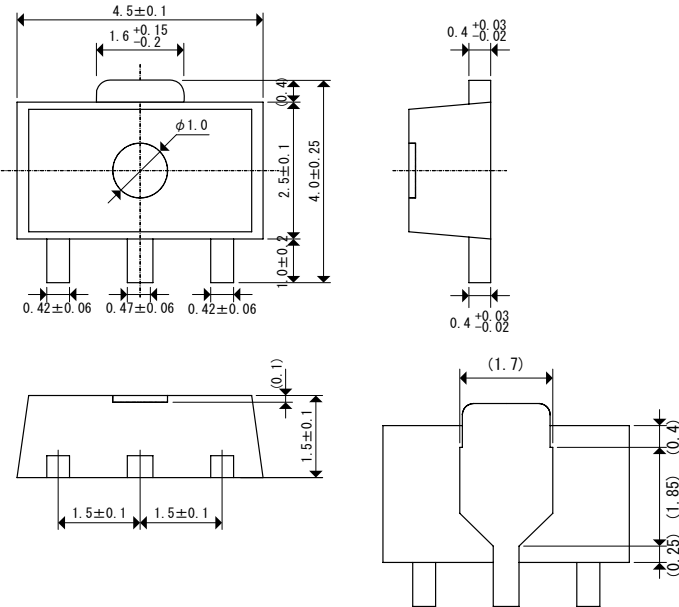

● SOT-89-5

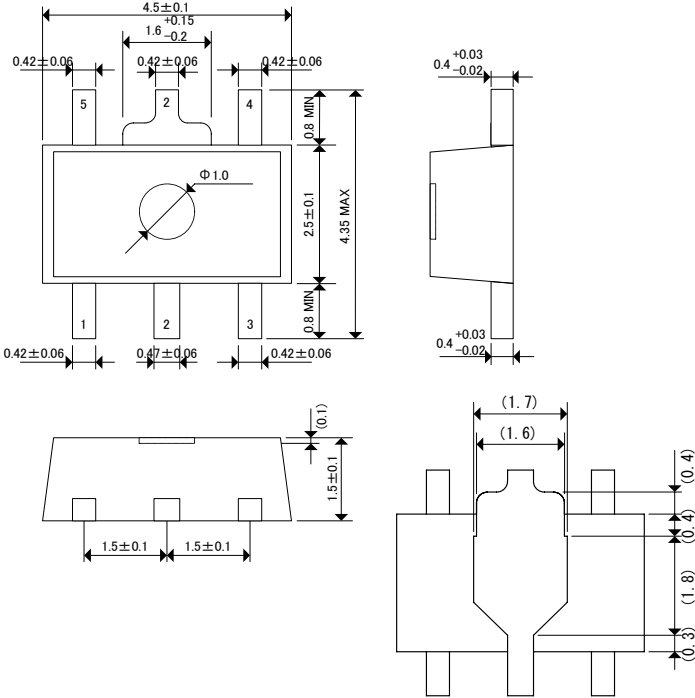

PACKAGING INFORMATION (Continued)

● USP-4 Reference Pattern Layout

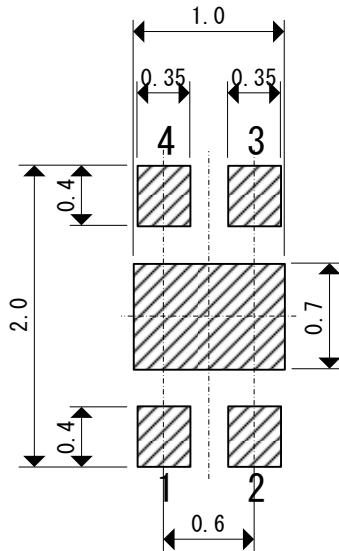

● USP-4 Reference Metal Mask Design

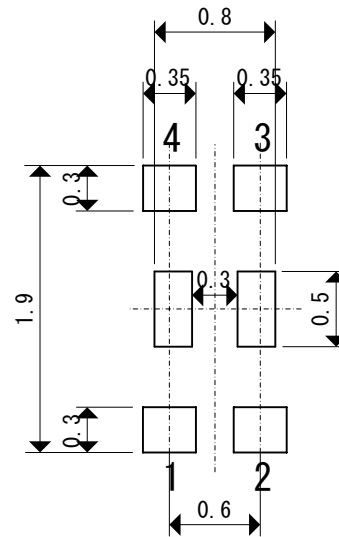

■ PACKAGING INFORMATION (Continued)

● USP-4 Power Dissipation

Power dissipation data for the USP-4 is shown in this page.

The value of power dissipation varies with the mount board conditions.

Please use this data as one of reference data taken in the described condition.

1. Measurement Condition (Reference data)

Condition:	Mount on a board
Ambient:	Natural convection
Soldering:	Lead (Pb) free
Board:	Dimensions 40 x 40 mm (1600 mm ² in one side) Copper (Cu) traces occupy 50% of the board area In top and back faces Package heat-sink is tied to the copper traces
Material:	Glass Epoxy (FR-4)
Thickness:	1.6 mm
Through-hole:	4 x 0.8 Diameter

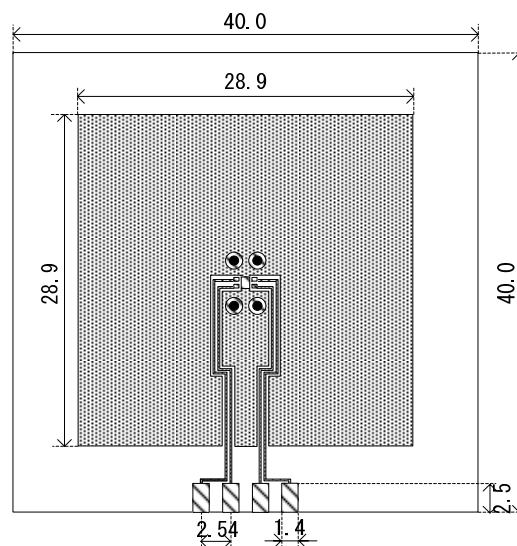

Evaluation Board (Unit: mm)

2. Power Dissipation vs. Ambient temperature

Board Mount ($T_J \text{ max} = 125^\circ\text{C}$)

Ambient Temperature ($^\circ\text{C}$)	Power Dissipation P_d (mW)	Thermal Resistance ($^\circ\text{C}/\text{W}$)
25	1000	100.00
85	400	

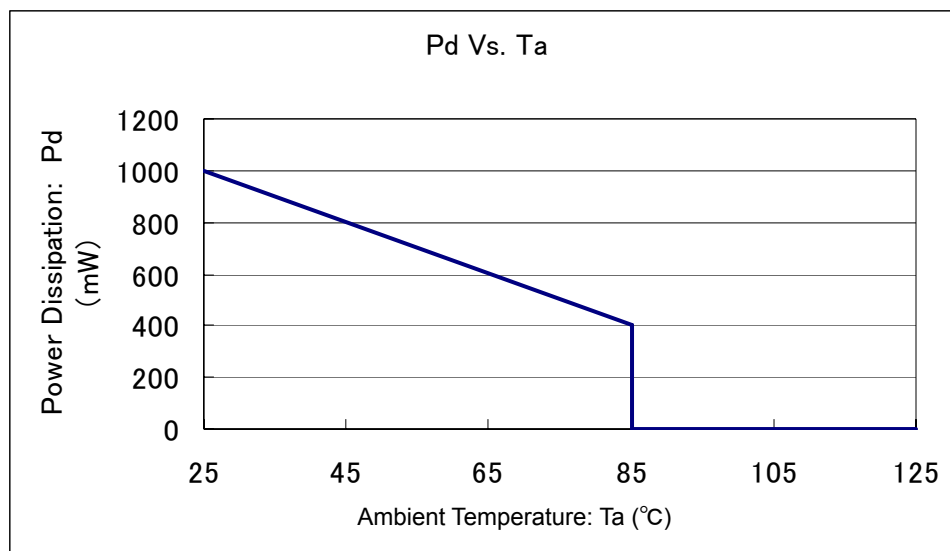

PACKAGING INFORMATION (Continued)

● SOT-25 Power Dissipation

Power dissipation data for the SOT-25 is shown in this page.

The value of power dissipation varies with the mount board conditions.

Please use this data as one of reference data taken in the described condition.

1. Measurement Condition (Reference data)

- Condition: Mount on a board
- Ambient: Natural convection
- Soldering: Lead (Pb) free
- Board: Dimensions 40 x 40 mm (1600 mm² in one side)
Copper (Cu) traces occupy 50% of the board area
In top and back faces
Package heat-sink is tied to the copper traces
(Board of SOT-26 is used.)
- Material: Glass Epoxy (FR-4)
- Thickness: 1.6 mm
- Through-hole: 4 x 0.8 Diameter

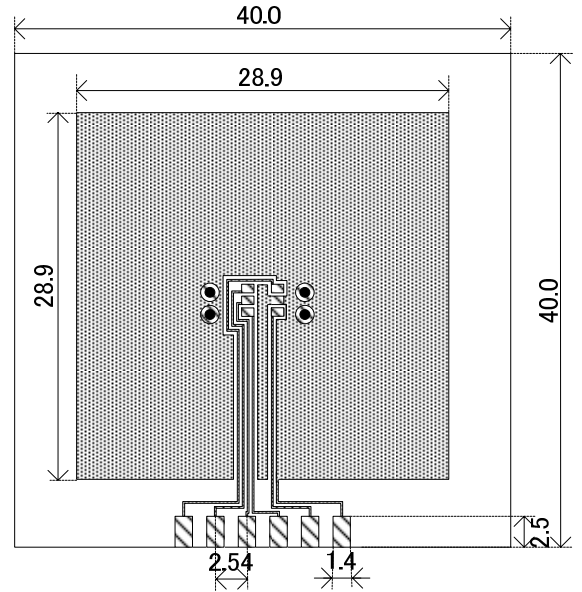

Evaluation Board (Unit: mm)

2. Power Dissipation vs. Ambient temperature

Board Mount ($T_j \text{ max} = 125^\circ\text{C}$)

Ambient Temperature ($^\circ\text{C}$)	Power Dissipation Pd (mW)	Thermal Resistance ($^\circ\text{C}/\text{W}$)
25	600	166.67
85	240	

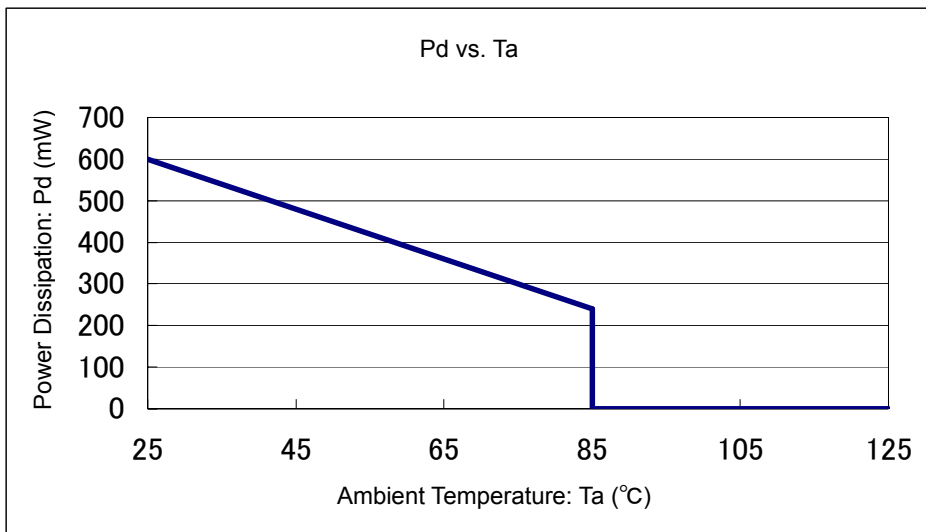

■ PACKAGING INFORMATION (Continued)

● SOT-89-5 Power Dissipation

Power dissipation data for the SOT-89-5 is shown in this page.
The value of power dissipation varies with the mount board conditions.
Please use this data as one of reference data taken in the described condition.

1. Measurement Condition (Reference data)

- Condition: Mount on a board
- Ambient: Natural convection
- Soldering: Lead (Pb) free
- Board: Dimensions 40 x 40 mm (1600 mm² in one side)
Copper (Cu) traces occupy 50% of the board area
In top and back faces
Package heat-sink is tied to the copper traces
- Material: Glass Epoxy (FR-4)
- Thickness: 1.6 mm
- Through-hole: 5 x 0.8 Diameter

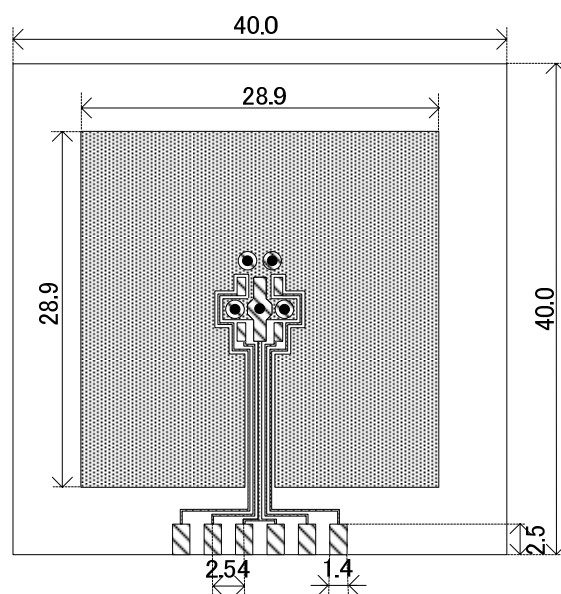

Evaluation Board (Unit: mm)

2. Power Dissipation vs. Ambient temperature

Board Mount ($T_j \text{ max} = 125^\circ\text{C}$)

Ambient Temperature ($^\circ\text{C}$)	Power Dissipation Pd (mW)	Thermal Resistance ($^\circ\text{C}/\text{W}$)
25	1300	76.92
85	520	

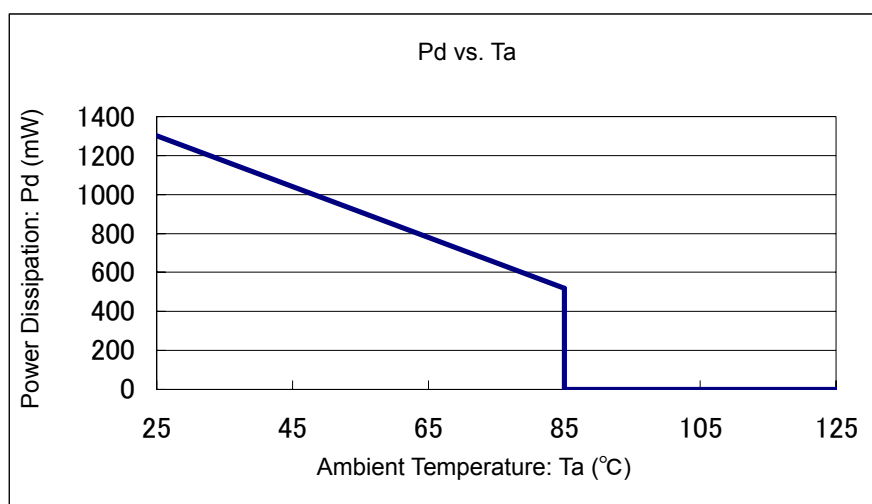

PACKAGING INFORMATION (Continued)

● SOT-89 Power Dissipation

Power dissipation data for the SOT-89 is shown in this page.

The value of power dissipation varies with the mount board conditions.

Please use this data as one of reference data taken in the described condition.

1. Measurement Condition (Reference data)

Condition : Mount on a board

Ambient : Natural convection

Soldering : Lead (Pb) free

Board : Dimensions 40×40mm (1600mm² in one side)

Copper (Cu) traces occupy 50% of the board area

In top and back faces

Package heat-sink is tied to the copper traces

Material : Glass Epoxy (FR-4)

Thickness : 1.6mm

Through-hole : 5 x 0.8 Diameter

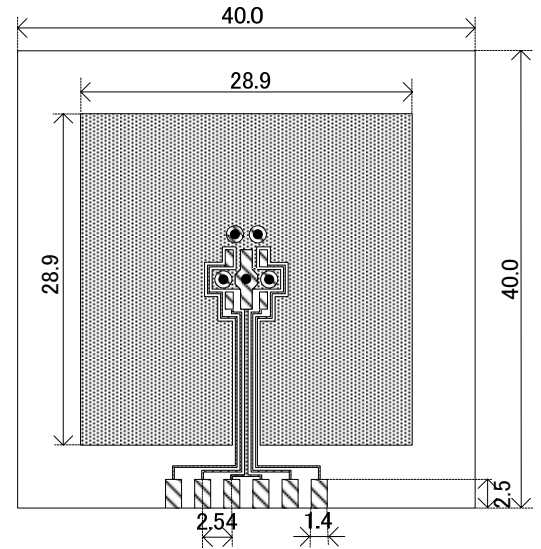

2. Power Dissipation vs. Ambient temperature

Board Mount (T_{jmax}=125°C)

Ambient Temperature (°C)	Power Dissipation Pd (mW)	Thermal Resistance (°C/W)
25	1000	100.00
85	400	

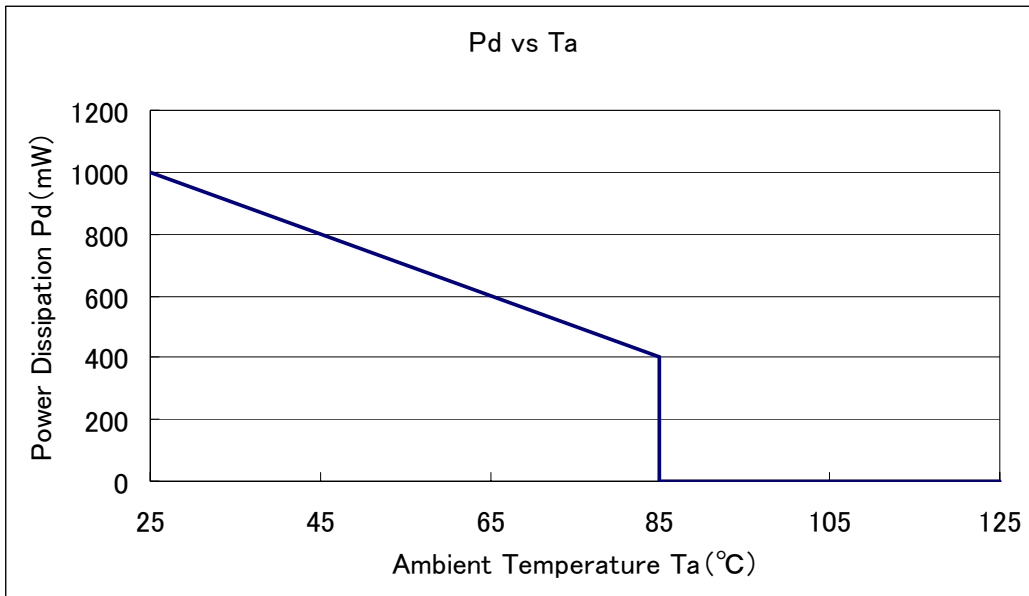

MARKING RULE

●SOT-25(Under dot), SOT-89, SOT-89-5, USP-4

① represents product series.

MARK	PRODUCT SERIES
1	XC6503*****-G

② represents type of regulators.

MARK				PRODUCT SERIES	PACKAGE
OUTPUT VOLTAGE 0.1V INCREMENTS		OUTPUT VOLTAGE 0.05V INCREMENTS			
VOLTAGE= 1.2~4.1V	VOLTAGE= 4.2~5.0V	VOLTAGE= 1.25~4.15V	VOLTAGE= 4.25~4.95V		
0	1	2	3	XC6503P*****-G	SOT-89
C	D	E	F	XC6503D*****-G	SOT-25, SOT-89-5, USP-4

③ represents output voltage.

MARK	OUTPUT VOLTAGE (V)				MARK	OUTPUT VOLTAGE (V)			
0	1.20	4.20	1.25	4.25	F	2.70	-	2.75	-
1	1.30	4.30	1.35	4.35	H	2.80	-	2.85	-
2	1.40	4.40	1.45	4.45	K	2.90	-	2.95	-
3	1.50	4.50	1.55	4.55	L	3.00	-	3.05	-
4	1.60	4.60	1.65	4.65	M	3.10	-	3.15	-
5	1.70	4.70	1.75	4.75	N	3.20	-	3.25	-
6	1.80	4.80	1.85	4.85	P	3.30	-	3.35	-
7	1.90	4.90	1.95	4.95	R	3.40	-	3.45	-
8	2.00	5.00	2.05	-	S	3.50	-	3.55	-
9	2.10	-	2.15	-	T	3.60	-	3.65	-
A	2.20	-	2.25	-	U	3.70	-	3.75	-
B	2.30	-	2.35	-	V	3.80	-	3.85	-
C	2.40	-	2.45	-	X	3.90	-	3.95	-
D	2.50	-	2.55	-	Y	4.00	-	4.05	-
E	2.60	-	2.65	-	Z	4.10	-	4.15	-

④⑤ represents production lot number

01 to 09, 0A to 0Z, 11 to 9Z, A1 to A9, AA to AZ, B1 to ZZ repeated. (G, I, J, O, Q, W excluded)

* No character inversion used.

●SOT-25(Under dot)

●SOT-89-5

●USP-4

●SOT-89

