



Chipsmall Limited consists of a professional team with an average of over 10 year of expertise in the distribution of electronic components. Based in Hongkong, we have already established firm and mutual-benefit business relationships with customers from,Europe,America and south Asia,supplying obsolete and hard-to-find components to meet their specific needs.

With the principle of “Quality Parts,Customers Priority,Honest Operation,and Considerate Service”,our business mainly focus on the distribution of electronic components. Line cards we deal with include Microchip,ALPS,ROHM,Xilinx,Pulse,ON,Everlight and Freescale. Main products comprise IC,Modules,Potentiometer,IC Socket,Relay,Connector.Our parts cover such applications as commercial,industrial, and automotives areas.

We are looking forward to setting up business relationship with you and hope to provide you with the best service and solution. Let us make a better world for our industry!



Contact us

Tel: +86-755-8981 8866 Fax: +86-755-8427 6832

Email & Skype: info@chipsmall.com Web: www.chipsmall.com

Address: A1208, Overseas Decoration Building, #122 Zhenhua RD., Futian, Shenzhen, China



500mA 1 Cell Li-ion and Li-Po Battery Linear Charger IC with Constant-Current/Constant-Voltage

■ GENERAL DESCRIPTION

The XC6801 series is a constant-current/constant-voltage linear charger IC for single cell Lithium-ion and Lithium polymer batteries. The XC6801 includes a reference voltage source, battery voltage monitor, driver transistor, constant-current/constant-voltage charge circuit, overheat protection circuit and phase compensation circuit. The battery charge termination voltage is internally set to $4.2V \pm 0.7\%$ and the trickle charge voltage and accuracy is $2.9V \pm 3\%$. In trickle charge mode, a safe Lithium-ion and Lithium polymer battery charge is possible because approximately only 1/10 of the full charge current is supplied to the battery. As it is possible to select a highly accurate charge current of either 100mA (MAX.) for L level input to the L_{IM} pin or 500mA (MAX.) for H level, the series is ideal for applications where the charge is from USB. The series' charge status output pin, /CHG pin, is capable of checking the IC's charging state via connection to an external LED.

■ APPLICATIONS

- USB charge applications
- Charging docks, charging cradles
- MP3 players, portable audio players
- Cellular phones, PDAs
- Bluetooth headsets

■ FEATURES

- Operating Voltage Range : 4.25V ~ 6.0V
- Charge Current : 100mA (MAX.) @ L_{IM} pin=L
(externally set) 500mA (MAX.) @ L_{IM} pin=H
- Charge Termination Voltage : $4.2V \pm 0.7\%$
- Trickle Charge Voltage : $2.9V \pm 3\%$
- Supply Current (Stand-by) : $12 \mu A$ (TYP.)
- Operating Ambient Temperature : $-40^{\circ}C \sim +85^{\circ}C$
- Packages : SOT-89-5, SOT-25, USP-6C
- Constant-current/constant-voltage operation with thermal shutdown
- Automatic recharge
- Charge status output pin
- Soft-start function (Inrush limit current)
- Environmentally Friendly : EU RoHS Compliant, Pb Free

■ TYPICAL APPLICATION CIRCUIT

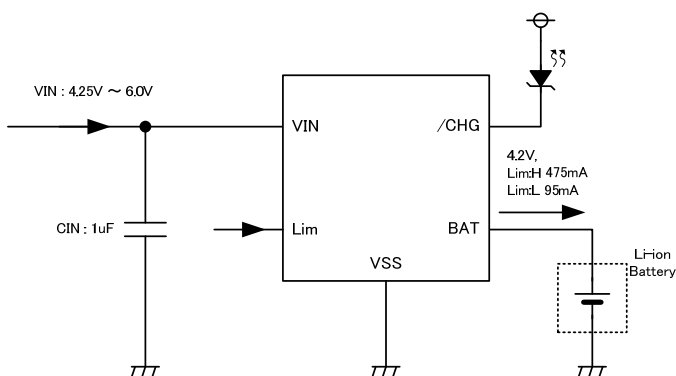

■ TYPICAL PERFORMANCE CHARACTERISTICS

- Battery Charge Cycle

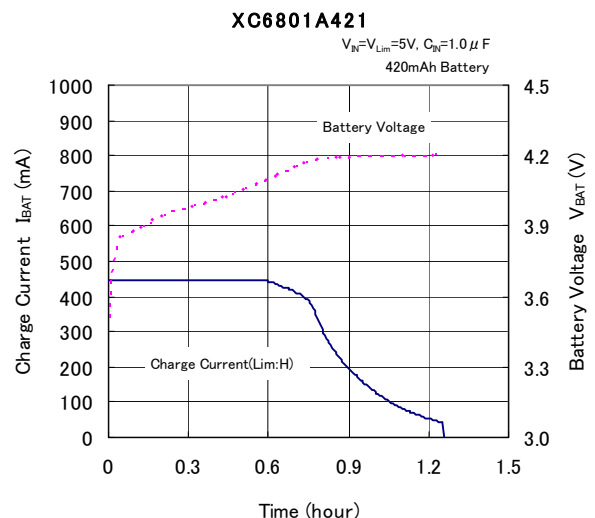

PIN CONFIGURATION

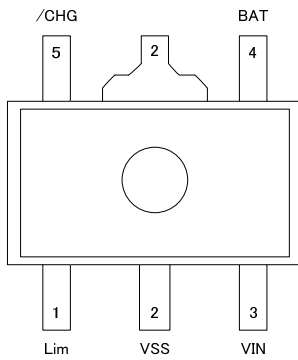

SOT-89-5
(TOP VIEW)

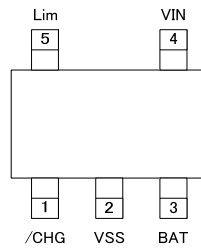

SOT-25
(TOP VIEW)

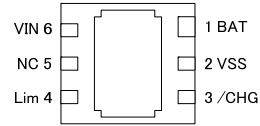

USP-6C
(BOTTOM VIEW)

* The dissipation pad for the USP-6C package should be solder-plated in recommended mount pattern and metal masking so as to enhance mounting strength and heat release. If the pad needs to be connected to other pins, it should be connected to the V_{SS} (No. 2) pin.

PIN ASSIGNMENT

PIN NUMBER			PIN NAME	FUNCTIONS
SOT-25	SOT-89-5	USP-6C		
1	5	3	/CHG	Charge Status Output Pin
2	2	2	V _{SS}	Ground
3	4	1	BAT	Charge Current Pin
4	3	6	V _{IN}	Input Voltage Pin
5	1	4	L _{IM}	Changing Current Switch
-	-	5	NC	No Connection

FUNCTIONS

XC6801A421

PIN NAME	CONDITIONS		IC OPERATION
L _{IM}	L	$0V \leq V_{LIM} \leq 0.4V$	Charging Battery Current 1 (CC Mode)
	H	$1V \leq V_{LIM} \leq 6V$	Charging Battery Current 2 (CC Mode)

*If L_{IM} pin is left open, battery current is unstable. L_{IM} pin level should be fixed "High" or "Low".

PRODUCT CLASSIFICATION

Ordering Information

XC6801A42①②③-④

DESIGNATOR	ITEM	SYMBOL	DESCRIPTION
①	Setting Charge Current	1	L _{IM} "L"=95mA, L _{IM} "H"=475mA
②③-④ ^(*)	Packages (Order Unit)	PR-G	SOT-89-5 (1,000/Reel)
		MR-G	SOT-25 (3,000/Reel)
		ER-G	USP-6C (3,000/Reel)

^(*) The "-G" suffix denotes Halogen and Antimony free as well as being fully EU RoHS compliant.

■ BLOCK DIAGRAM

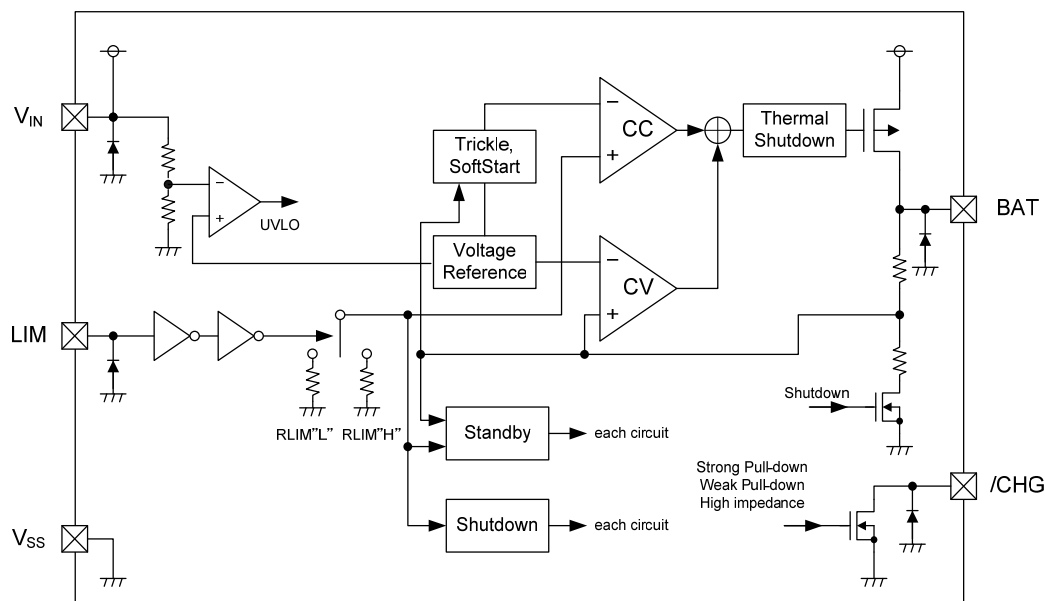

* Diodes inside the circuits are ESD protection diodes and parasitic diodes.

■ ABSOLUTE MAXIMUM RATINGS

Ta=25°C			
PARAMETER	SYMBOL	RATINGS	UNIT
V _{IN} Pin Voltage	V _{IN}	-0.3 ~ +6.5	V
L _{IM} Pin Voltage	V _{LIM}	-0.3 ~ +6.5	V
BAT Pin Voltage	V _{BAT}	-0.3 ~ +6.5	V
/CHG Pin Voltage	V _{/CHG}	-0.3 ~ +6.5	V
BAT Pin Current	I _{BAT}	900 ^(*)	mA
Power Dissipation	SOT-25	250	mW
		600 (PCB mounted) ^(*)	
	SOT-89-5	500	
		1300 (PCB mounted) ^(*)	
	USP-6C	120	
		1000 (PCB mounted) ^(*)	
Operating Ambient Temperature	T _{opr}	- 40 ~ + 85	°C
Storage Temperature	T _{stg}	- 55 ~ + 125	°C

All voltages are described based on the V_{SS} pin.

(*) Please use within the range of $I_{BAT} \leq Pd / (V_{IN} - V_{BAT})$.

(*) The power dissipation figure shown is PCB mounted. Please refer to page 16 to 18 for details.

ELECTRICAL CHARACTERISTICS

XC6801A421

Ta=25°C

PARAMETER	SYMBOL	CONDITIONS	MIN	TYP	MAX	UNIT	CIRCUIT
Input Voltage	V _{IN}		4.25	-	6.00	V	-
Supply Current	I _{SS}	Charge mode (V _{LIM} =H or V _{LIM} =L)	-	12	30	μA	③
Stand-by Current	I _{STBY}	Stand-by mode	-	12	30	μA	③
Shut-down Current	I _{SHUT}	Shut-down mode (V _{IN} <V _{BAT} or V _{IN} <V _{UVLO})	-	8	18	μA	③
Float Voltage 1	V _{FLOAT1}	Ta=25°C, I _{BAT} =40mA	×0.993	4.2	×1.007	V	②
Float Voltage 2 (*1)	V _{FLOAT2}	0°C ≤ Ta ≤ 50°C, I _{BAT} =40mA	×0.99	4.2	×1.01	V	-
Battery Current 1	I _{BAT1}	V _{BAT} =3.8V, V _{LIM} =L, CC mode	88	95	100	mA	③
Battery Current 2	I _{BAT2}	V _{BAT} =3.8V, V _{LIM} =H, CC mode	440	475	500	mA	③
Battery Current 3	I _{BAT3}	Stand-by mode, V _{BAT} =4.2V	-	-	2.5	μA	③
Battery Current 4	I _{BAT4}	Shut-down mode	-	-	2.0	μA	③
Battery Current 5	I _{BAT5}	Stop mode, V _{IN} =0V	-	-	2.0	μA	③
Trickle Charge Current 1	I _{TRIKL1}	V _{BAT} <V _{TRIKL} (V _{LIM} =L)	7.5	9.5	12.0	mA	③
Trickle Charge Current 2	I _{TRIKL2}	V _{BAT} <V _{TRIKL} (V _{LIM} =H)	37.5	47.5	60.0	mA	③
Trickle Voltage	V _{TRIKL}	V _{LIM} =L, V _{BAT} Rising	2.813	2.9	2.987	V	③
Trickle Voltage Hysteresis Width	V _{TRIKL_HYS}	V _{LIM} =L	58	90	116	mV	③
UVLO Voltage	V _{UVLO}	V _{IN} : L → H	3.686	3.8	3.914	V	⑥
UVLO Hysteresis Width	V _{UVLO_HYS}	-	150	190	280	mV	-
V _{IN} -V _{BAT} Shut-down Voltage	V _{ASD}	V _{IN} : L → H	70	100	140	mV	③
V _{IN} -V _{BAT} Shut-down Voltage Hysteresis Width	V _{ASD_HYS}	-	50	70	90	mV	-
C/10 Charge Termination Current Threshold	I _{TERM}	V _{LIM} =L	0.07	0.1	0.13	mA/mA	②
		V _{LIM} =H	0.07	0.1	0.13	mA/mA	②
/CHG Pin Weak Pull-Down Current	I _{/CHG1}	V _{BAT} =4.3V, V _{/CHG} =5V	8	20	35	μA	③
/CHG Pin Strong Pull-Down Current	I _{/CHG2}	V _{BAT} =4.0V, V _{/CHG} =1V	4	10	18	mA	③
/CHG Pin Output Low Voltage	V _{/CHG}	I _{/CHG} =5mA	-	0.35	0.60	V	④
Recharge Battery Threshold Voltage	ΔV _{RECHRG}	V _{FLOAT1} -V _{RECHRG} (*2)	100	150	200	mV	③
ON Resistance	R _{ON}	-	300	450	800	mΩ	①
Soft-Start Time	t _{SS}	I _{BAT} =0 → I _{BAT2} (V _{LIM} =H)	120	150	180	μs	⑤
Recharge Battery Time	t _{RECHRG}	V _{BAT} : H → L	0.4	1.7	3.2	ms	⑥
Battery Termination Detect Time	t _{TERM}	I _{BAT} falling (Less than I _{TERM})	0.3	1.2	2.4	ms	⑥
L _{LIM} Pin "H" Level Voltage	V _{LIM_H}		1			V	③
L _{LIM} Pin "L" Level Voltage	V _{LIM_L}				0.4	V	③
L _{LIM} Pin "H" Level Current	I _{LIM_H}		-0.1		0.1	μA	①
L _{LIM} Pin "L" Level Current	I _{LIM_L}		-0.1		0.1	μA	①
Thermal Shut-Down Detect Temperature	T _{TSD}	Junction temperature		120		°C	-
Thermal Shut-Down Release Temperature	T _{TSR}	Junction temperature		100		°C	-

Unless otherwise stated, V_{IN}=5.0V.

(*1) The figures under the condition of 0°C ≤ T_a ≤ 50°C are guaranteed by design calculation.

(*2) V_{RECHRG} is a voltage to start recharging while reducing V_{BAT} in stand-by mode from the full charge.

OPERATIONAL DESCRIPTION

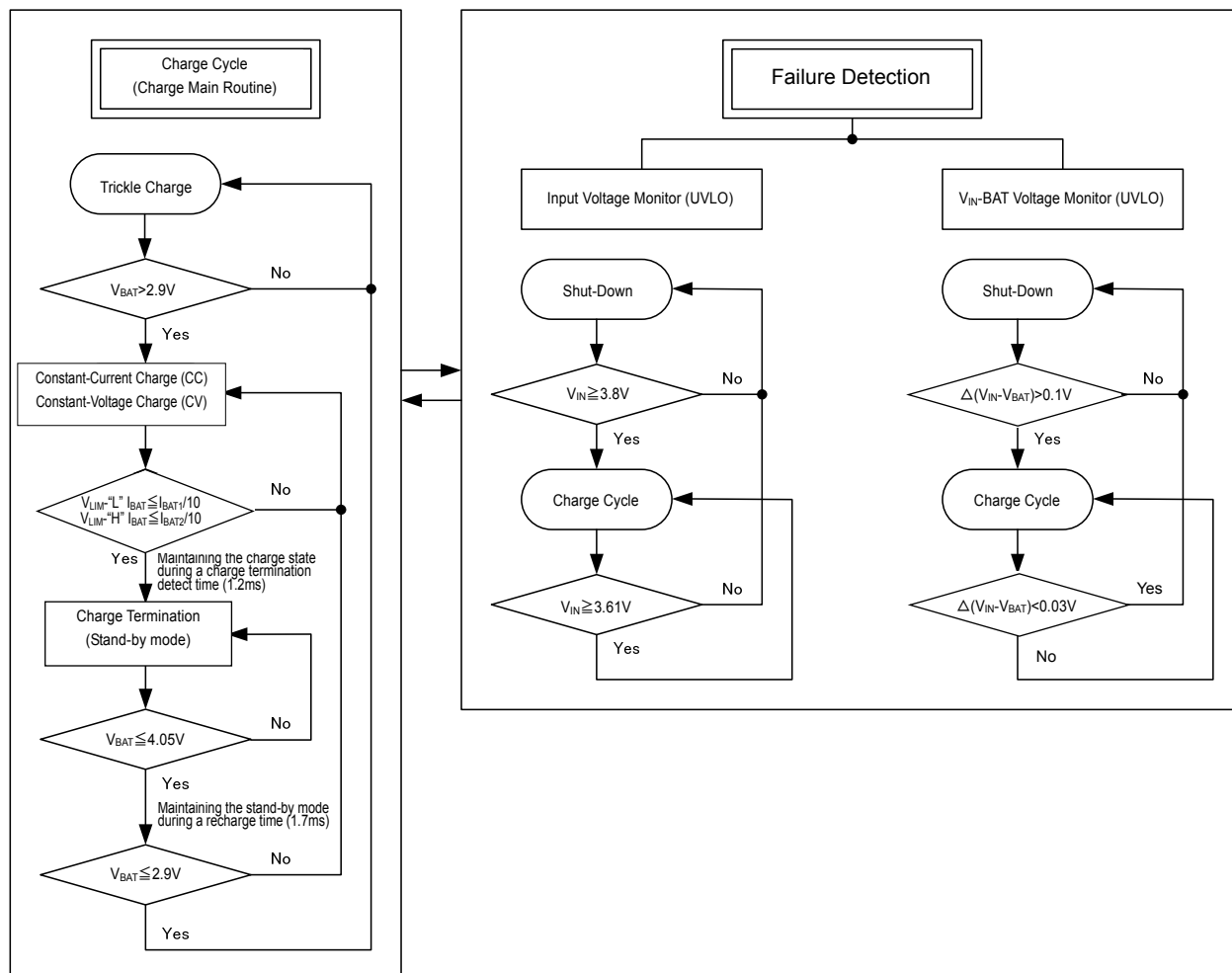

<Charge Cycle>

If the BAT pin trickle voltage is less than 2.9V(TYP.), the charger enters trickle charge mode. In this mode, a safe battery charge is possible because approximately only 1/10 of the charge current is supplied to the battery. When the BAT pin voltage rises above trickle voltage, the charger enters constant-current mode (CC mode) and the battery is charged by the programmed charge current. When the BAT pin voltage reaches 4.2V, the charger enters constant-voltage mode (CV mode) automatically. After this, the charge current starts to drop and when it reaches a level which is 1/10 of the programmed charge current, the charge terminates.

<Setting Charge Current>

The charge current can be set from 475mA(TYP.) or 95mA(TYP.) by the LIM pin.

LIM "H" level input: 475mA(TYP.)

LIM "L" level input: 95mA(TYP.)

<Charge Termination>

The battery charge is terminated when the charge current decreases to 1/10 of the full charging level after the battery pin voltage reaches a float voltage. An internal comparator monitors the ISEN pin voltage to detect the charge termination. When the comparator sees that the ISEN pin voltage is less than 1.2ms (charge termination detect time), the IC enters stand-by mode. A driver transistor turns off during the stand-by mode.

<Automatic Recharge>

In stand-by mode battery voltage falls. When the voltage level at the battery pin drops to recharge battery threshold voltage 4.05V(TYP.) or less, the charge cycle automatically re-start after a delay of 1.7ms. As such, no external activation control is needed.

OPERATIONAL EXPLANATION (Continued)

<Charge Condition Status>

The /CHG pin constantly monitors the charge states classified as below:

- Strong pull-down: $I_{/CHG}=10\text{mA}$ (TYP.) in a charge cycle,
- Weak pull-down: $I_{/CHG}=20\ \mu\text{A}$ (TYP.) in a stand-by mode,
- High impedance: in shutdown mode.

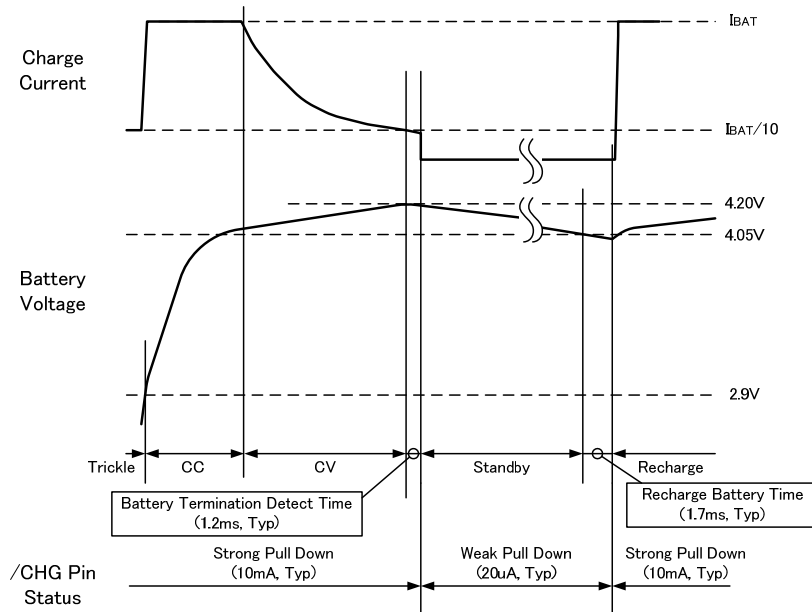

<Connection of Shorted BAT Pin>

Even if the BAT pin is shorted to V_{SS} , a trickle charge mode operates in order to protect the IC from destruction caused by over current.

<Under-voltage Lockout (UVLO)>

The UVLO circuit keeps the charger in shut-down mode until the input voltage, V_{IN} , rises above the UVLO voltage. Moreover, in order to protect the battery charger, the UVLO circuit keeps the charger in shut-down mode when the voltage between the input pin voltage and BAT pin voltage falls to less than 30mV. The charge will not restart until the voltage between the input pin voltage and BAT pin voltage rises more than 100mV. During shut-down mode, the driver transistor turns off but a failure detection circuit operates, and supply current is reduced to $8\ \mu\text{A}$.

<Soft-Start Function>

To protect against inrush current from the input to the battery, soft-start time is optimized and internally set ($150\ \mu\text{s}$, TYP.).

<Backflow Prevention Between the BAT Pin and the V_{IN} Pin>

A backflow prevention circuit protects against current flowing from the BAT pin to the V_{IN} pin even if the BAT pin voltage is higher than the V_{IN} pin voltage.

■NOTES ON USE

1. For temporary, transitional voltage drop or voltage rising phenomenon, the IC is liable to malfunction should the ratings be exceeded.
2. Where wiring impedance is high, operations may become unstable due to noise and/or phase lag depending on output current. Please wire the C_{IN} as close to the IC as possible.
3. Torex places an importance on improving our products and their reliability.
We request that users incorporate fail-safe designs and post-aging protection treatment when using Torex products in their systems.

TEST CIRCUITS

CIRCUIT①

ON Resistance, L_{IM} Pin "H" level current, L_{IM} Pin "L" level current,

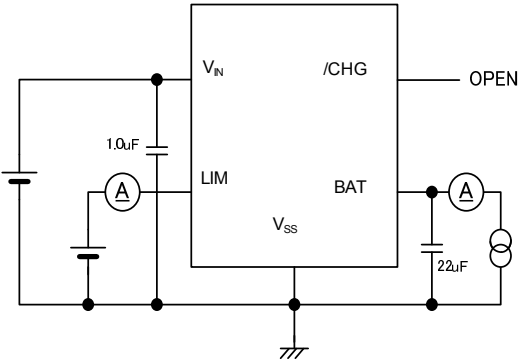

CIRCUIT②

C/10 Charge Termination Current Threshold, Battery Termination Voltage

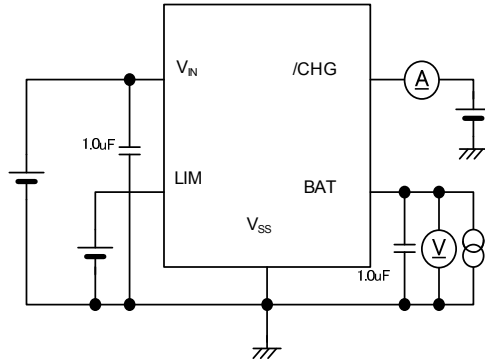

CIRCUIT③

Trickle Charge Current1~2, Battery Current1~5, L_{IM} Pin "H" level Voltage, L_{IM} Pin "L" level Voltage, Trickle Charge Voltage, Recharge Battery Threshold Voltage, $V_{IN}-V_{BAT}$ Shut-down Voltage, /CHG Pin Weak_Pull_down Current, /CHG Pin Strong_Pull_down Current, Supply Current, Stand-by Current, Shut-down Current

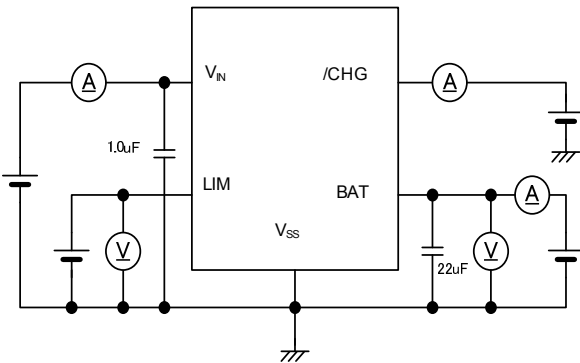

CIRCUIT④

/CHG Pin Output Low Voltage

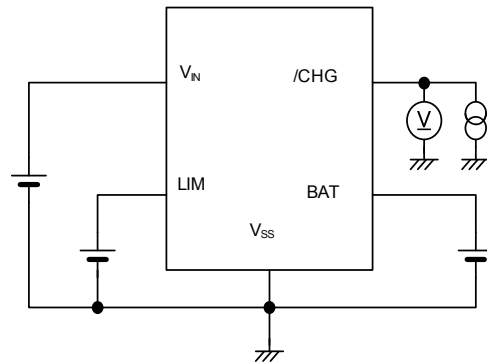

CIRCUIT⑤

Soft-Start Time

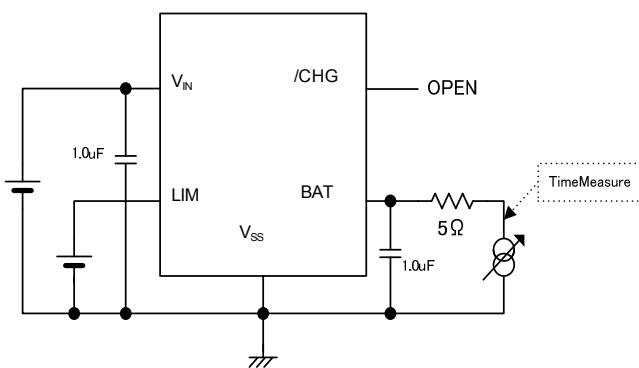

CIRCUIT⑥

Recharge Time at Charge Termination Detect, UVLO Voltage

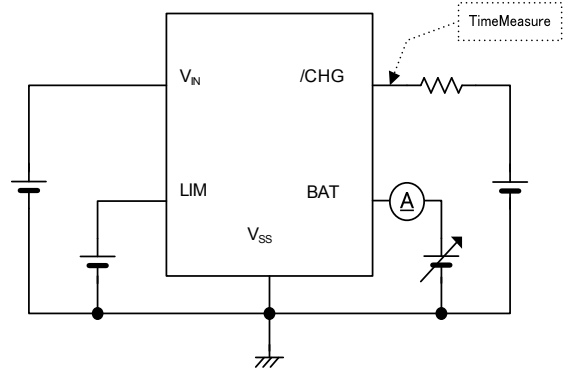

TYPICAL PERFORMANCE CHARACTERISTICS

(1) Charge Cycle

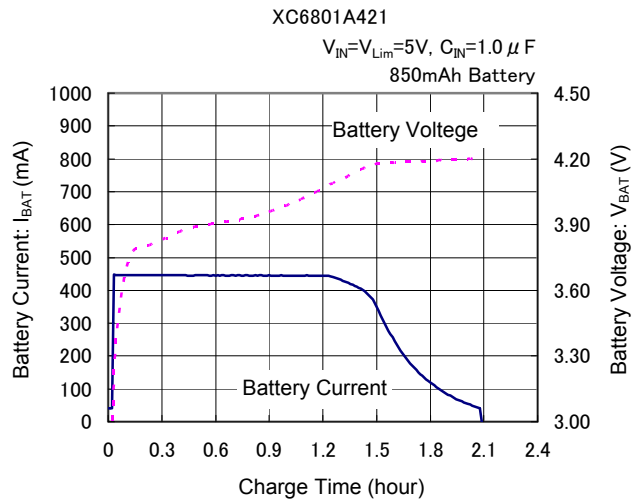
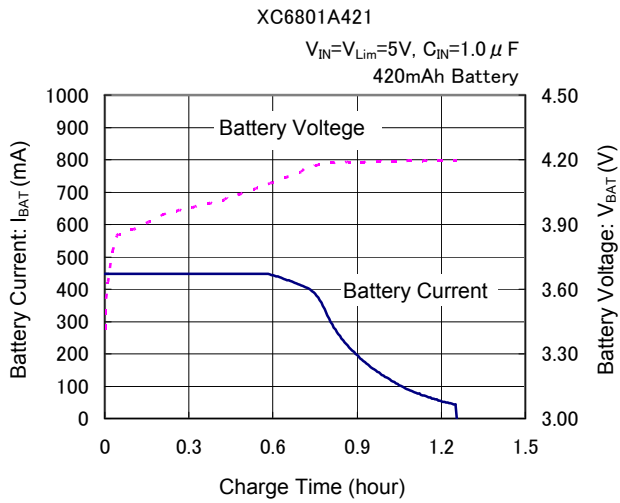

(2) Battery Current vs. Battery Voltage

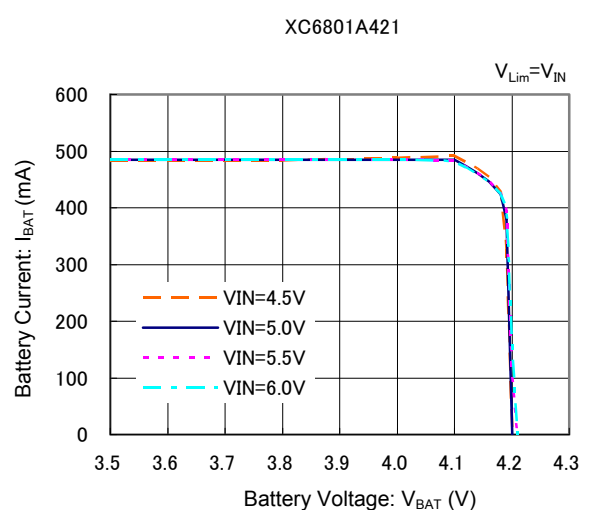
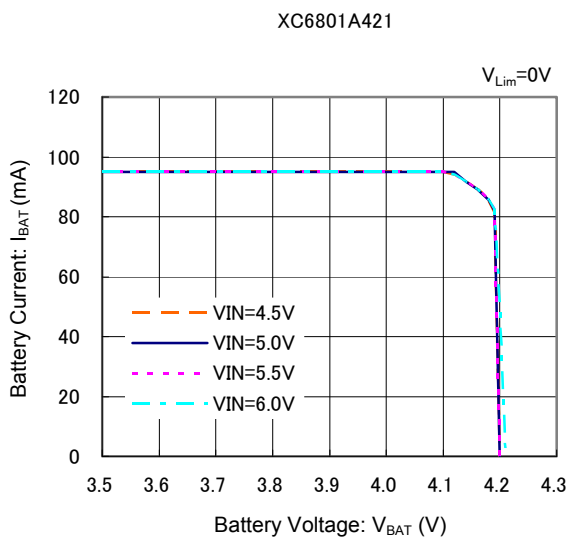
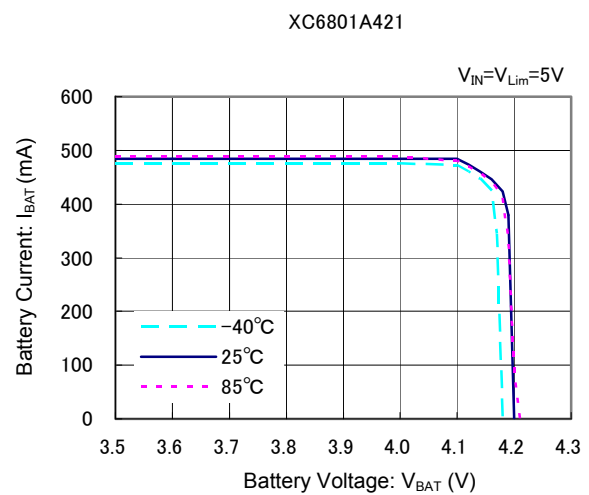
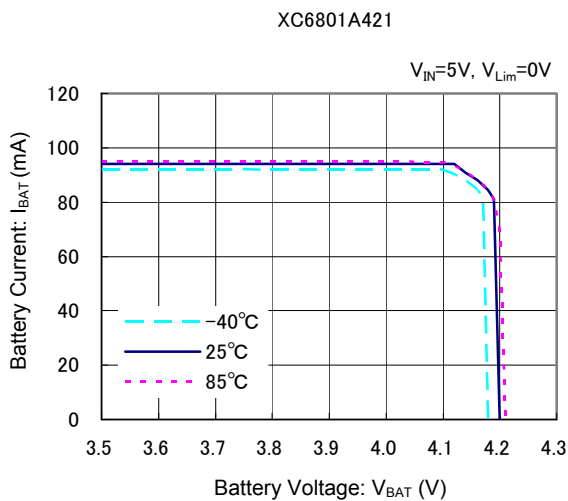

TYPICAL PERFORMANCE CHARACTERISTICS (Continued)

(3) Battery Voltage vs. Battery Current

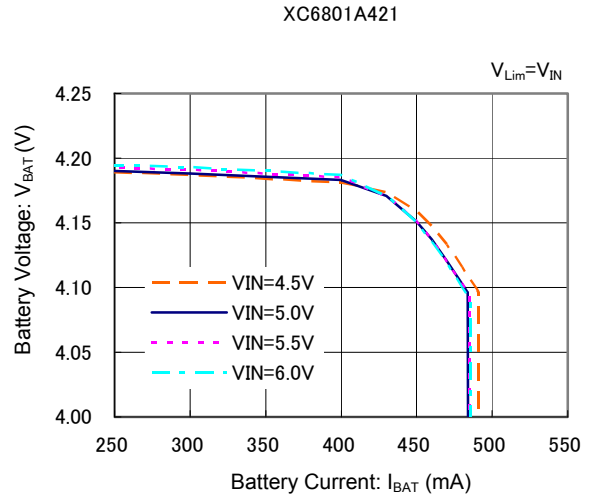
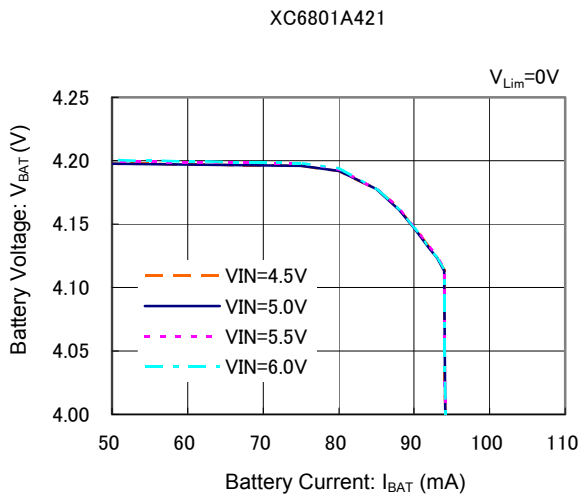
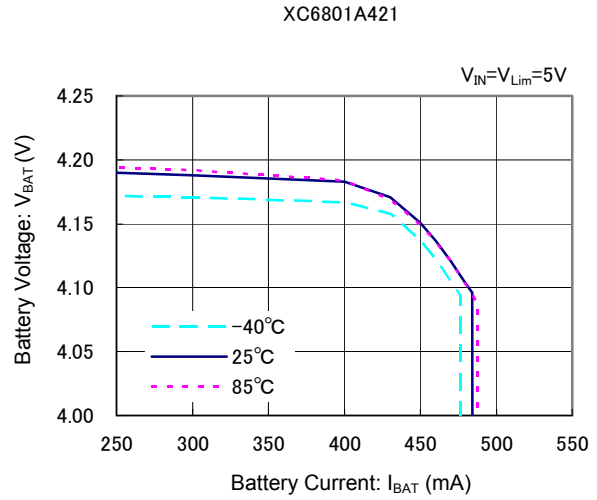
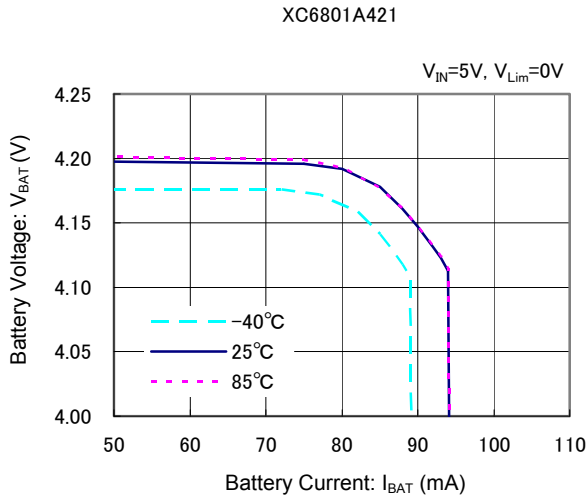

(4) Charge Termination Voltage vs. Ambient Temperature

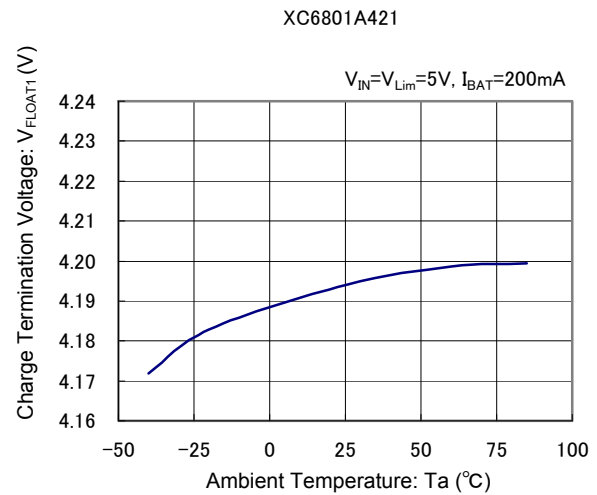
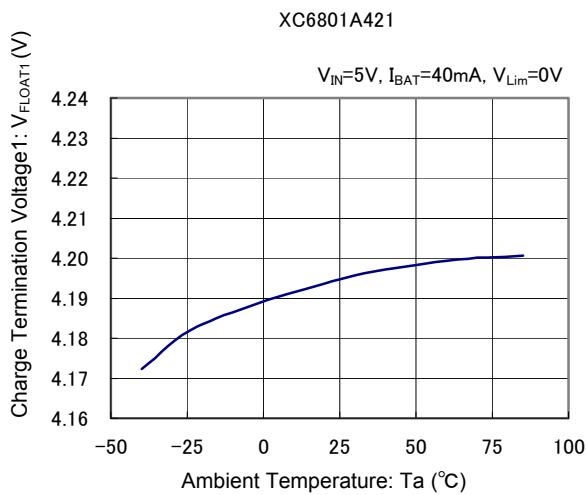

■ TYPICAL PERFORMANCE CHARACTERISTICS (Continued)

(5) Battery Current vs. Ambient Temperature

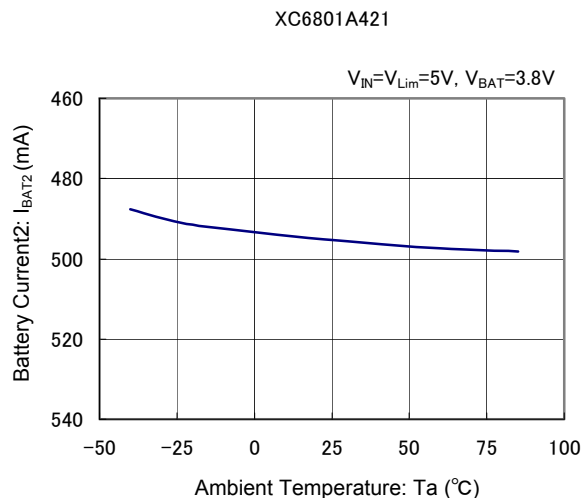
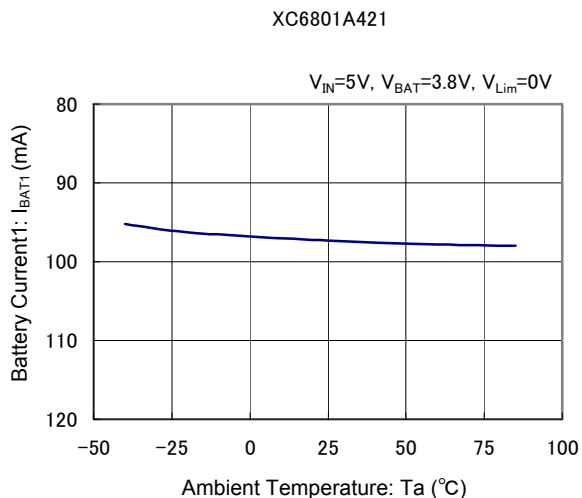

(6) Trickle Charge Current vs. Ambient Temperature

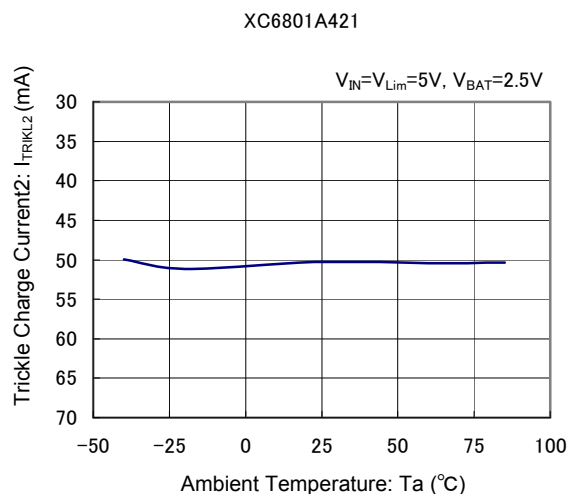
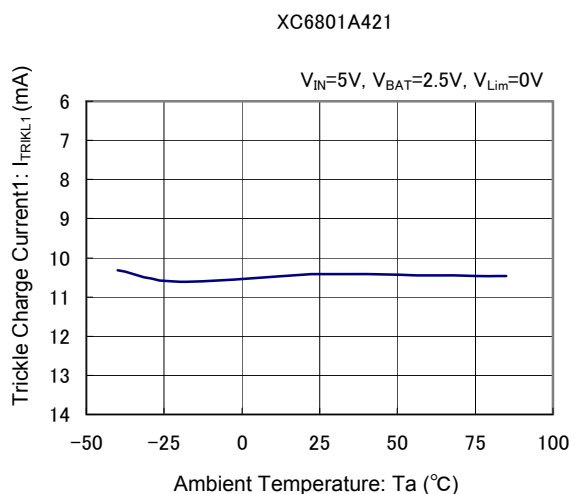

(7) Trickle Voltage vs. Ambient Temperature

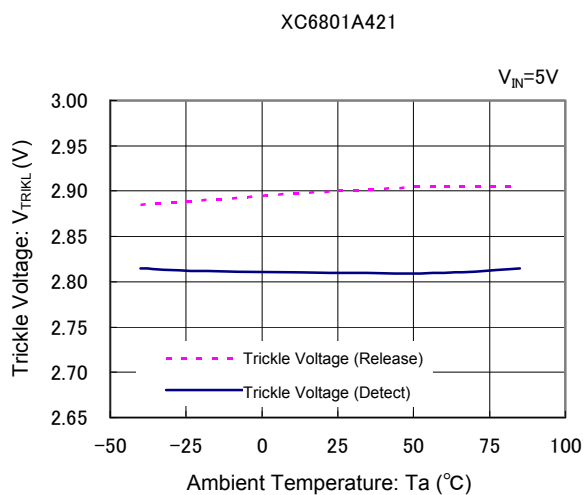

(8) UVLO Voltage vs. Ambient Temperature

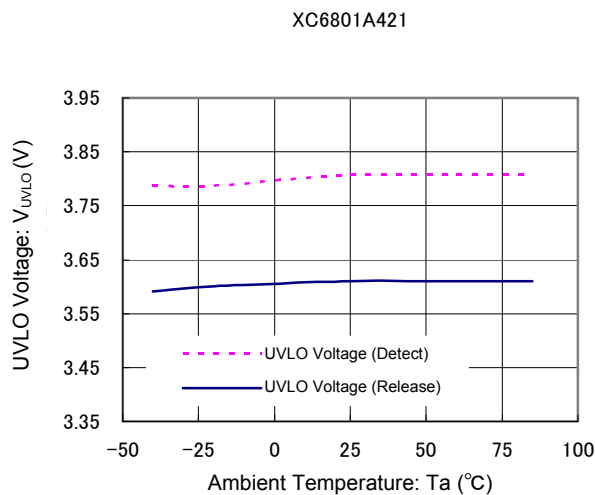

TYPICAL PERFORMANCE CHARACTERISTICS (Continued)

(9) $V_{IN} - V_{BAT}$ Shutdown Voltage vs. Ambient Temperature

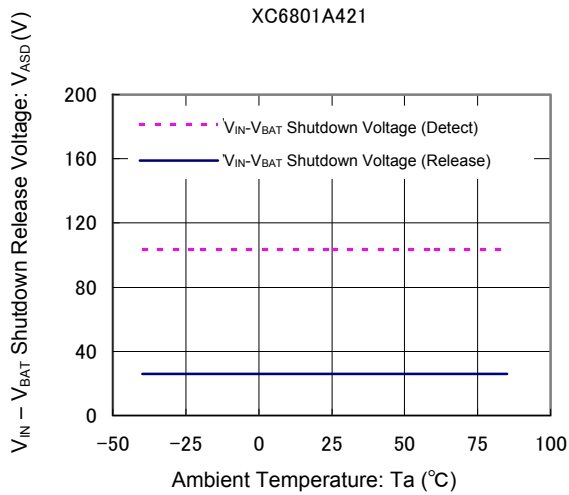

(10) Charge Termination Detect Time vs. Ambient Temperature

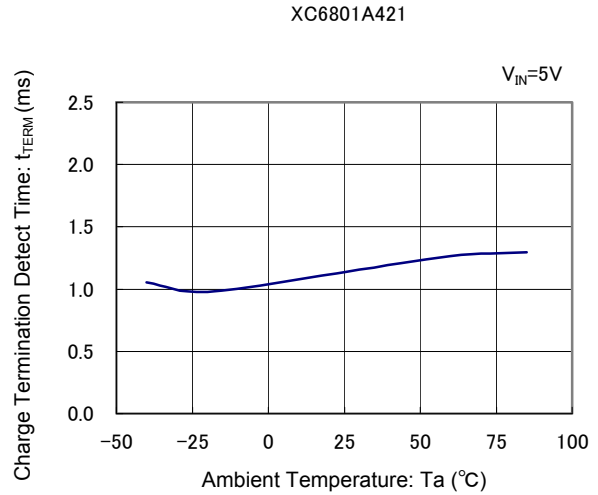

(11) Recharge Time vs. Ambient Temperature

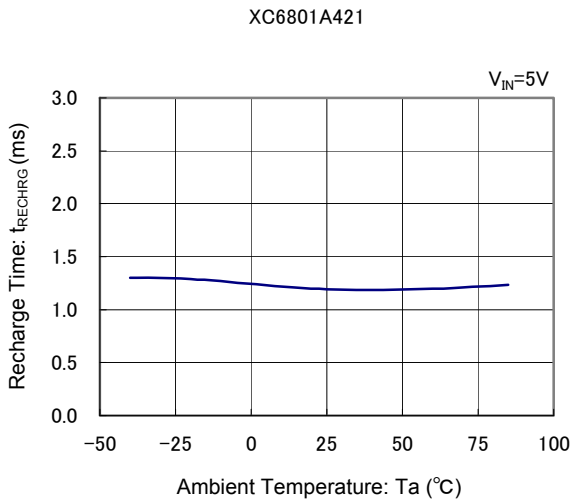

(12) Recharge Threshold Voltage vs. Ambient Temperature

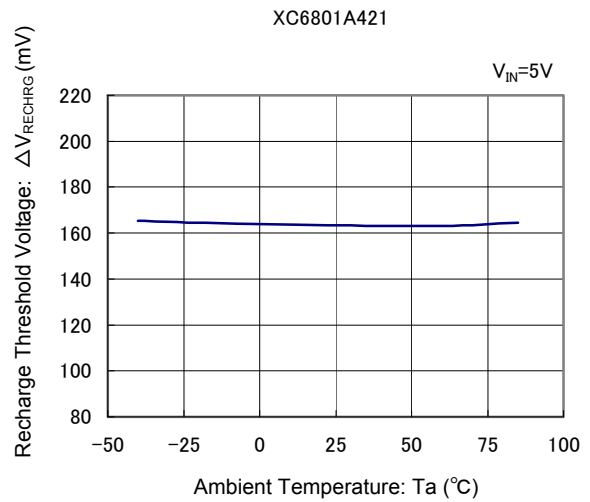

(13) Soft Start Time vs. Ambient Temperature

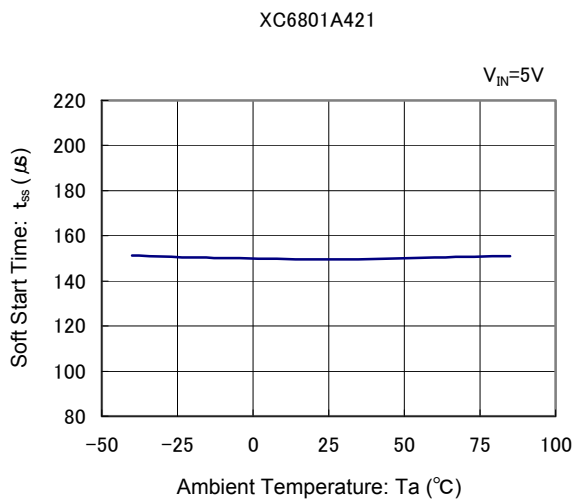

(14) ON Resistance vs. Ambient Temperature

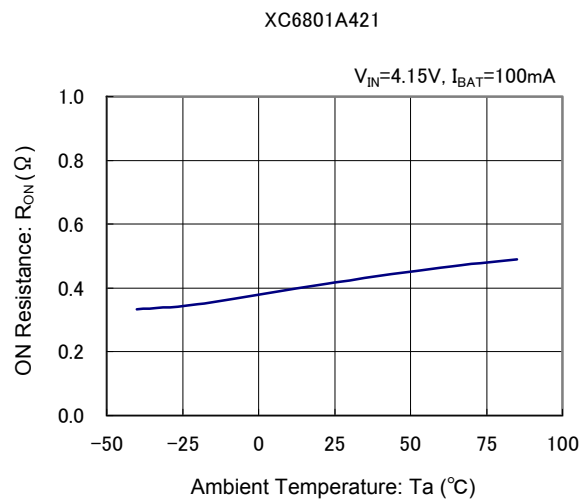

■ TYPICAL PERFORMANCE CHARACTERISTICS (Continued)

(15) Shutdown Current vs. Ambient Temperature

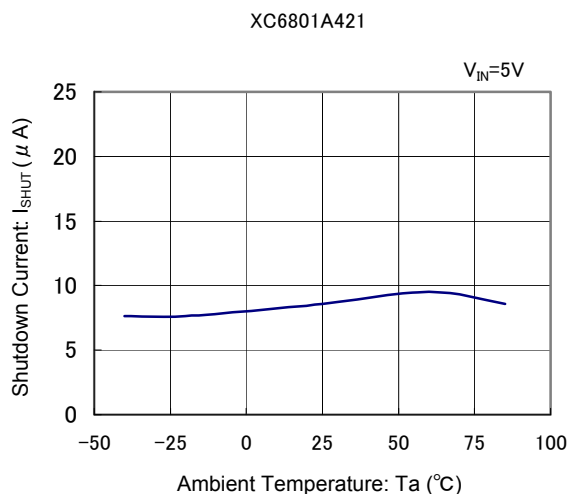

(16) Stand-by Current vs. Ambient Temperature

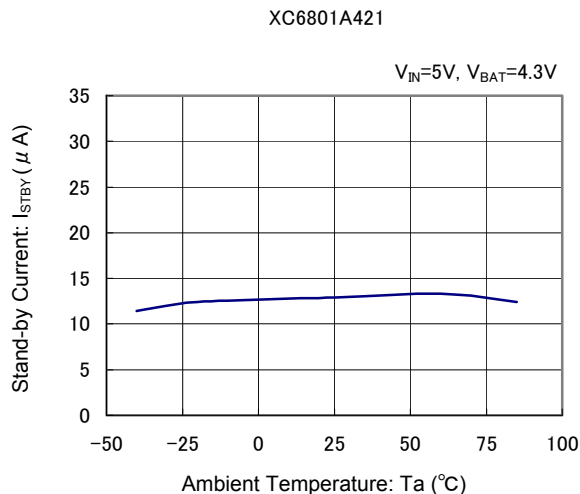

(17) /CHG Weak Pull Down Current vs. /CHG Pin Voltage

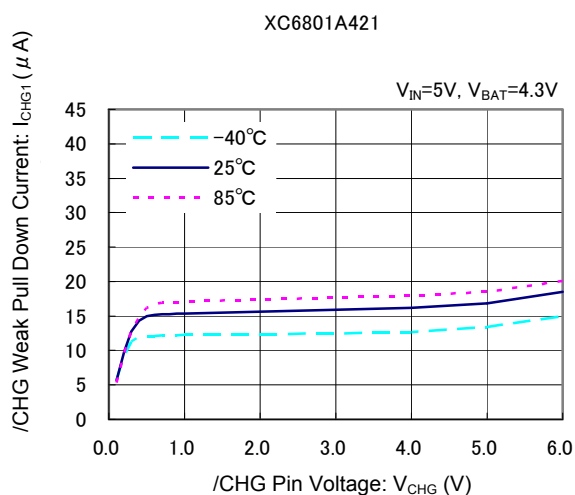

(18) /CHG Strong Pull Down Current vs. /CHG Pin Voltage

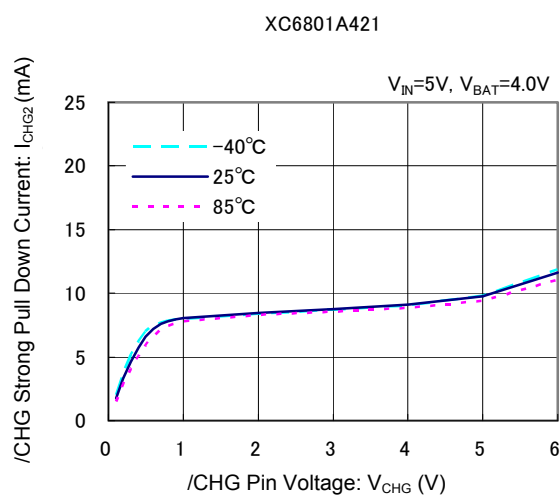

(19) /CHG Pin Output Low Voltage vs. Ambient Temperature

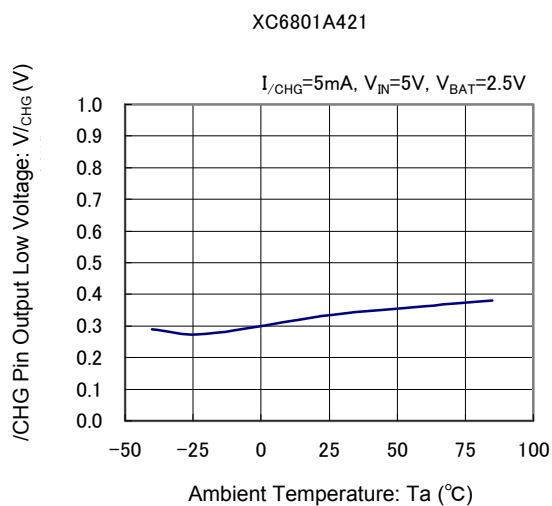

PACKAGING INFORMATION

● SOT-25

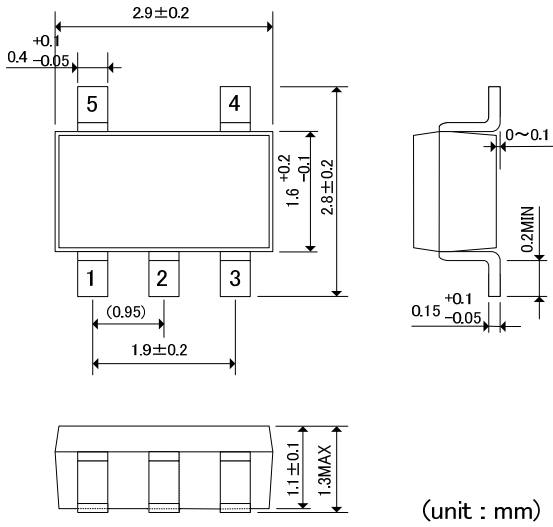

● SOT-89-5

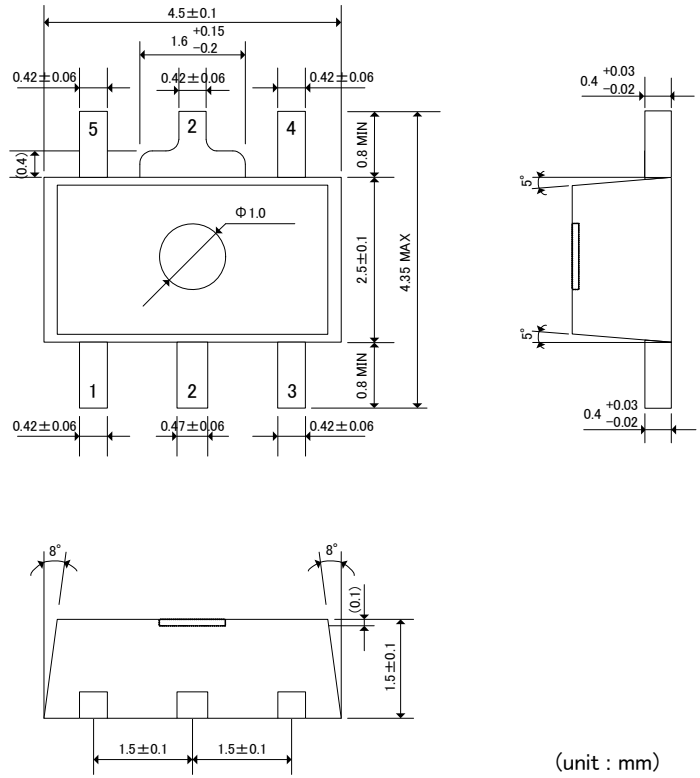

● USP-6C

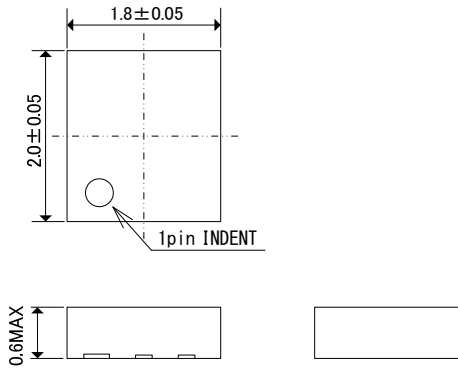

● USP-6C Reference Pattern Layout

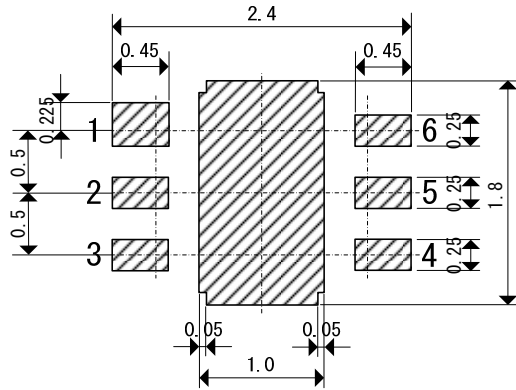

● USP-6C Reference Metal Mask Design

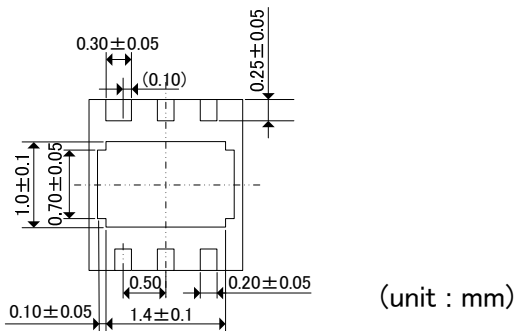

MARKING RULE

SOT-25

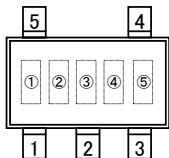

① represents product series

MARK	PRODUCT SERIES
4	XC6801*****-G

② represents the 7th digits

MARK	PRODUCT SERIES
A	XC6801A****-G

SOT-89-5

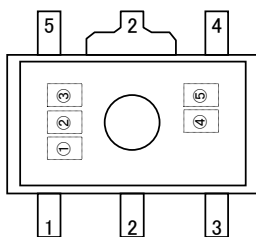

③ represents the 8th digits

MARK	PRODUCT SERIES
4	XC6801*4****-G

④⑤ represents production lot number

01~09, 0A~0Z, 11~09Z, A1~A9, AA ~Z9, ZA~ZZ in order.

(G, I, J, O, Q, W excepted)

*No character inversion used.

USP-6C

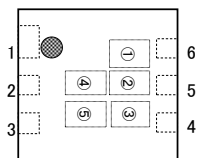

PACKAGING INFORMATION (Continued)

SOT-89-5 Power Dissipation

Power dissipation data for the SOT-89-5 is shown in this page.
 The value of power dissipation varies with the mount board conditions.
 Please use this data as one of reference data taken in the described condition.

1. Measurement Condition (Reference data)

- Condition: Mount on a board
- Ambient: Natural convection
- Soldering: Lead (Pb) free
- Board: Dimensions 40 x 40 mm (1600 mm² in one side)
 Copper (Cu) traces occupy 50% of the board area
 In top and back faces
 Package heat-sink is tied to the copper traces
- Material: Glass Epoxy (FR-4)
- Thickness: 1.6 mm
- Through-hole: 5 x 0.8 Diameter

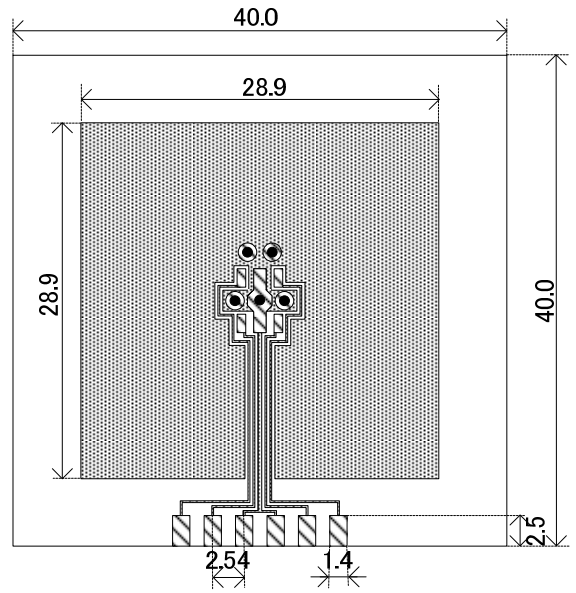

Evaluation Board (Unit: mm)

2. Power Dissipation vs. Ambient Temperature

Board Mount ($T_j \text{ max} = 125^\circ\text{C}$)

Ambient Temperature ($^\circ\text{C}$)	Power Dissipation Pd (mW)	Thermal Resistance ($^\circ\text{C}/\text{W}$)
25	1300	76.92
85	520	

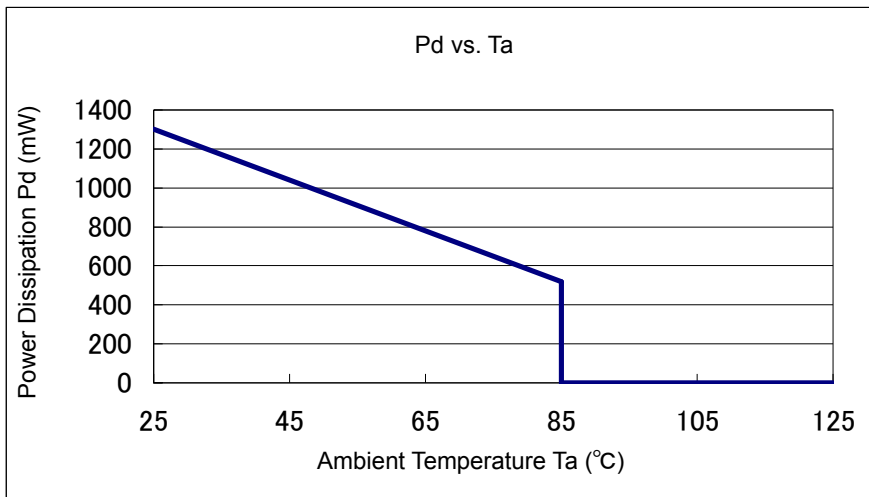

■ PACKAGING INFORMATION (Continued)

● SOT-25 Power Dissipation

Power dissipation data for the SOT-25 is shown in this page.
The value of power dissipation varies with the mount board conditions.
Please use this data as one of reference data taken in the described condition.

1. Measurement Condition (Reference data)

- Condition: Mount on a board
- Ambient: Natural convection
- Soldering: Lead (Pb) free
- Board: Dimensions 40 x 40 mm (1600 mm² in one side)
Copper (Cu) traces occupy 50% of the board area
In top and back faces
Package heat-sink is tied to the copper traces
(Board of SOT-26 is used.)
- Material: Glass Epoxy (FR-4)
- Thickness: 1.6 mm
- Through-hole: 4 x 0.8 Diameter

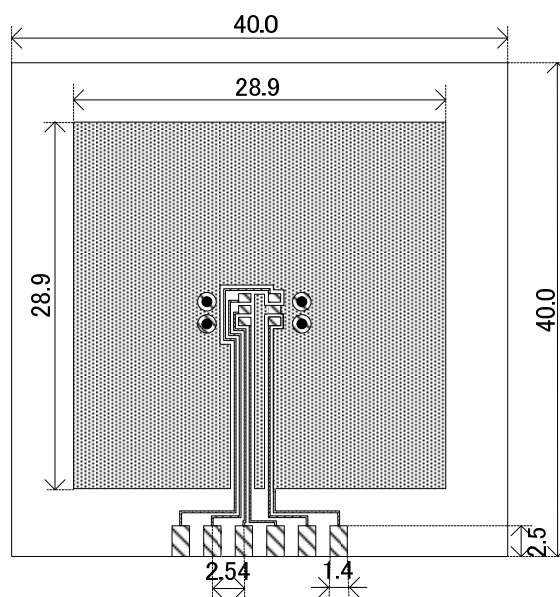

Evaluation Board (Unit: mm)

2. Power Dissipation vs. Ambient Temperature

Board Mount ($T_j \text{ max} = 125^\circ\text{C}$)

Ambient Temperature ($^\circ\text{C}$)	Power Dissipation Pd (mW)	Thermal Resistance ($^\circ\text{C}/\text{W}$)
25	600	166.67
85	240	

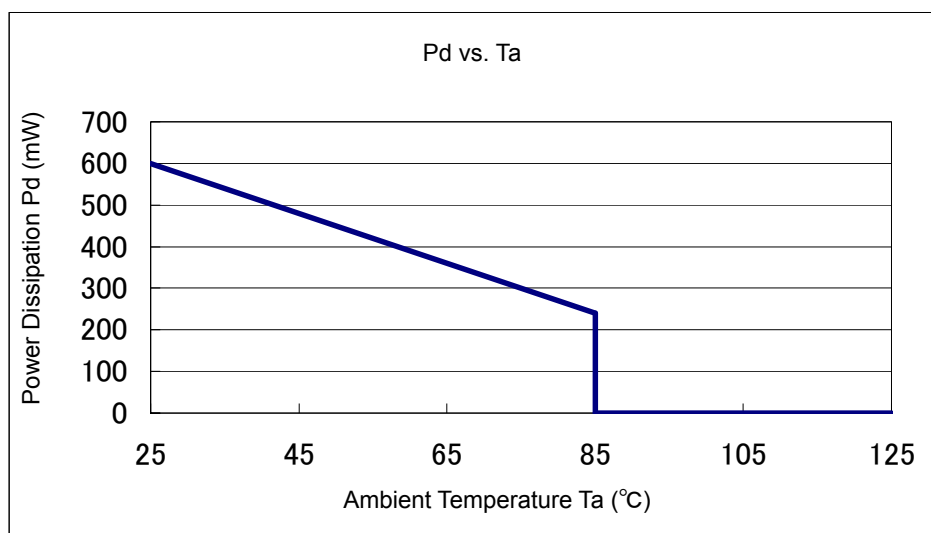

PACKAGING INFORMATION (Continued)

● USP-6C Power Dissipation

Power dissipation data for the USP-6C is shown on this page.
 The value of power dissipation varies with the mount board conditions.
 Please use this data as one of reference data taken in the described condition.

1. Measurement Condition (Reference data)

- Condition: Mount on a board
- Ambient: Natural convection
- Soldering: Lead (Pb) free
- Board: Dimensions 40 x 40 mm (1600 mm² in one side)
 Copper (Cu) traces occupy 50% of the board area
 In top and back faces
 Package heat-sink is tied to the copper traces
- Material: Glass Epoxy (FR-4)
- Thickness: 1.6 mm
- Through-hole: 4 x 0.8 Diameter

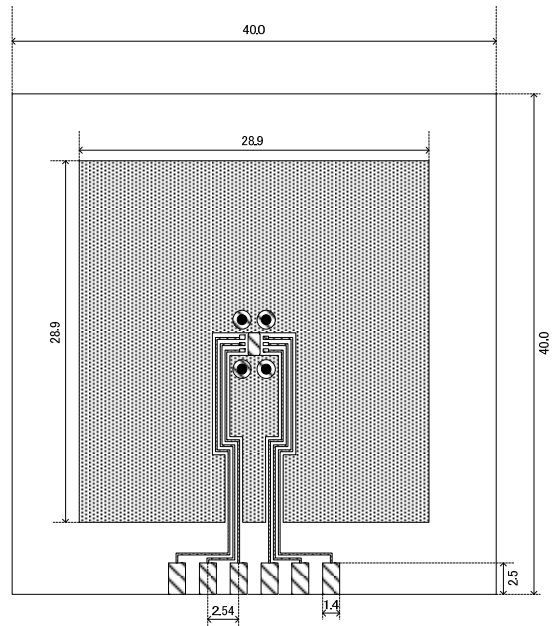

Evaluation Board (Unit: mm)

2. Power Dissipation vs. Ambient Temperature

Board Mount ($T_j \text{ max} = 125^\circ\text{C}$)

Ambient Temperature ($^\circ\text{C}$)	Power Dissipation Pd (mW)	Thermal Resistance ($^\circ\text{C}/\text{W}$)
25	1000	100
85	400	

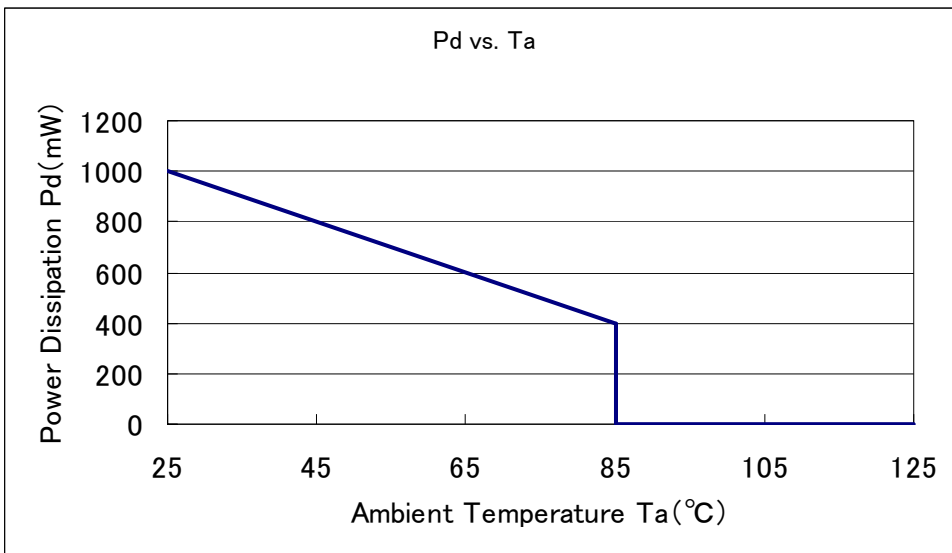

1. The products and product specifications contained herein are subject to change without notice to improve performance characteristics. Consult us, or our representatives before use, to confirm that the information in this datasheet is up to date.
2. We assume no responsibility for any infringement of patents, patent rights, or other rights arising from the use of any information and circuitry in this datasheet.
3. Please ensure suitable shipping controls (including fail-safe designs and aging protection) are in force for equipment employing products listed in this datasheet.
4. The products in this datasheet are not developed, designed, or approved for use with such equipment whose failure or malfunction can be reasonably expected to directly endanger the life of, or cause significant injury to, the user.
(e.g. Atomic energy; aerospace; transport; combustion and associated safety equipment thereof.)
5. Please use the products listed in this datasheet within the specified ranges.
Should you wish to use the products under conditions exceeding the specifications, please consult us or our representatives.
6. We assume no responsibility for damage or loss due to abnormal use.
7. All rights reserved. No part of this datasheet may be copied or reproduced without the prior permission of TOREX SEMICONDUCTOR LTD.

TOREX SEMICONDUCTOR LTD.