



Chipsmall Limited consists of a professional team with an average of over 10 year of expertise in the distribution of electronic components. Based in Hongkong, we have already established firm and mutual-benefit business relationships with customers from,Europe,America and south Asia,supplying obsolete and hard-to-find components to meet their specific needs.

With the principle of "Quality Parts,Customers Priority,Honest Operation,and Considerate Service",our business mainly focus on the distribution of electronic components. Line cards we deal with include Microchip,ALPS,ROHM,Xilinx,Pulse,ON,Everlight and Freescale. Main products comprise IC,Modules,Potentiometer,IC Socket,Relay,Connector.Our parts cover such applications as commercial,industrial, and automotives areas.

We are looking forward to setting up business relationship with you and hope to provide you with the best service and solution. Let us make a better world for our industry!



## Contact us

Tel: +86-755-8981 8866 Fax: +86-755-8427 6832

Email & Skype: [info@chipsmall.com](mailto:info@chipsmall.com) Web: [www.chipsmall.com](http://www.chipsmall.com)

Address: A1208, Overseas Decoration Building, #122 Zhenhua RD., Futian, Shenzhen, China



# XC74WL240ASR



## CMOS Logic

- ◆ CMOS Logic Dual Bus Buffer  
(Inverted 3-state outputs)
- ◆ Operating Voltage Range : 2V ~ 5.5V
- ◆ High Speed Operations : tpd = 3.8ns (TYP.)
- ◆ Low Power Consumption : 2μ A(MAX.)
- ◆ MSOP-8B Package

### ■ GENERAL DESCRIPTION

XC74WL240ASR is dual bus buffer manufactured using silicon gate CMOS processes. The small supply current, which is one of the features of the CMOS logic, gives way to high speed operations which enables LS-TTL.

With wave forming buffers connected internally, stabilized output can be achieved as the series offers high noise immunity.

As the series is integrated into a mini molded, MSOP-8B package, high density mounting is possible.

### ■ APPLICATIONS

- Palmtops
- Digital equipment

### ■ FEATURES

**High Speed Operations** : tpd = 3.8ns (TYP.) (Vcc=5V)

**Operating Voltage Range** : 2V ~ 5.5V

**Low Power Consumption**: 2μ A (MAX.)

**Small Package** : MSOP-8B

### ■ PIN CONFIGURATION

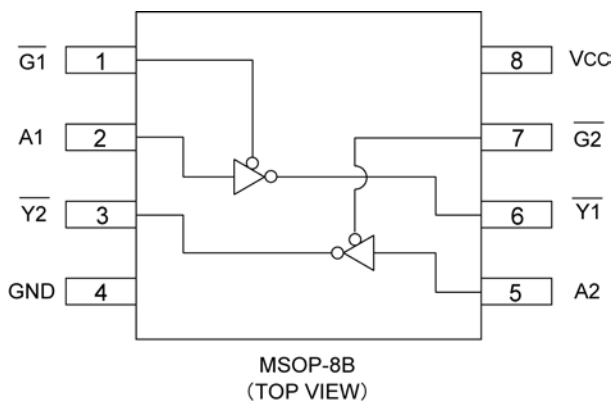

### ■ FUNCTIONS

INPUT		OUTPUT
$\overline{G}$	A	$\overline{Y}$
H	X	Z
L	H	L
L	L	H

H=High level

L=Low level

X=Don't care

Z=High impedance

### ■ ABSOLUTE MAXIMUM RATINGS

Ta=-40°C~85°C

PARAMETER	SYMBOL	RATINGS	UNITS
Supply Voltage	VCC	-0.5~+6.0	V
Input Voltage	VIN	-0.5~+6.0	V
Output Voltage	VOUT	-0.5~VCC+0.5	V
Input Diode Current	I <sub>IK</sub>	-20	mA
Output Diode Current	I <sub>OK</sub>	± 20	mA
Switch Output Current	I <sub>OUT</sub>	± 25	mA
VCC,GND Current	I <sub>CC</sub> ,I <sub>GND</sub>	± 50	mA
Power Dissipation (Ta = 25°C)	P <sub>d</sub>	300	mW
Storage Temperature Range	T <sub>stg</sub>	-65~+150	°C

Note : Voltage is all ground standardized.

# XC74WL240ASR

## RECOMMENDED OPERATING CONDITIONS

PARAMETER	SYMBOL	CONDITIONS	UNITS
Supply Voltage	V <sub>CC</sub>	2~5.5	V
Input Voltage	V <sub>IN</sub>	0~5.5	V
Output Voltage	V <sub>OUT</sub>	0~V <sub>CC</sub>	V
Operating Temperature Range	T <sub>opr</sub>	-40~+85	°C
Input Rise and Fall Time	tr,tf	0~200 ( V <sub>CC</sub> =3.3V )	ns
		0~100 ( V <sub>CC</sub> =5V )	

## DC ELECTRICAL CHARACTERISTICS

PARAMETER	SYMBOL	V <sub>CC</sub> (V)	CONDITIONS	Ta=25°C			Ta=-40°C~85°C		UNITS		
				MIN.	TYP.	MAX.	MIN.	MAX.			
Input Voltage	V <sub>IH</sub>	2.0		1.50	-	-	1.50	-	V		
		3.0		2.10	-	-	2.10	-			
		5.5		3.85	-	-	3.85	-			
	V <sub>IL</sub>	2.0		-	-	0.50	-	0.50	V		
		3.0		-	-	0.90	-	0.90			
		5.5		-	-	1.65	-	1.65			
Output Voltage	V <sub>OH</sub>	2.0	V <sub>IN</sub> =V <sub>IL</sub>	I <sub>OH</sub> =-50μ A	1.90	2.00	-	1.90	-	V	
		3.0			2.90	3.00	-	2.90	-		
		4.5			4.40	4.50	-	4.40	-		
		3.0		I <sub>OH</sub> =-4mA	2.58	-	-	2.48	-		
		4.5			I <sub>OH</sub> =-8mA	3.94	-	-	3.80		-
	V <sub>OL</sub>	V <sub>IN</sub> =V <sub>IH</sub>	2.0	I <sub>OL</sub> =50μ A	-	-	0.10	-	0.10	V	
					3.0	-	-	0.10	-		0.10
					4.5	-	-	0.10	-		0.10
			3.0		I <sub>OL</sub> =4mA	-	-	0.36	-		0.44
			4.5			I <sub>OL</sub> =8mA	-	-	0.36		-
3 State Off-Leak Current	I <sub>oz</sub>	5.0	V <sub>IN</sub> =V <sub>IL</sub> or V <sub>IH</sub> , V <sub>OUT</sub> =V <sub>CC</sub> or GND	-0.25	-	0.25	-2.50	2.50	μ A		
Input Current	I <sub>IN</sub>	0~5.5	V <sub>IN</sub> =V <sub>CC</sub> or GND	-0.10	-	0.1	-1.00	1.00	μ A		
Static Supply Current	I <sub>CC</sub>	5.5	V <sub>IN</sub> =V <sub>CC</sub> or GND	-	-	2.0	-	20.0	μ A		

## ■ SWITCHING ELECTRICAL CHARACTERISTICS

(tr=tf=3ns)

PARAMETER	SYMBOL	CONDITIONS		Ta=25°C			Ta=-40°C~85°C		UNITS		
		CL	Vcc(V)	MIN.	TYP.	MAX.	MIN.	MAX.			
Delay Time	tPLH	15pF	3.3		-	5.6	8.0	1.0	9.5	ns	
			5.0		-	3.8	5.5	1.0	6.5		
		50pF	3.3		-	8.1	11.5	1.0	13.0	ns	
			5.0		-	5.3	7.5	1.0	8.5		
	tPHL	15pF	3.3		-	5.6	8.0	1.0	9.5	ns	
			5.0		-	3.8	5.5	1.0	6.5		
		50pF	3.3		-	8.1	11.5	1.0	13.0	ns	
			5.0		-	5.3	7.5	1.0	8.5		
Output Enable Time	tZL	15pF	3.3	RL=1kΩ	-	5.4	8.0	1.0	9.5	ns	
			5.0		-	3.6	5.1	1.0	6.0		
		50pF	3.3			-	7.9	11.5	1.0	13.0	ns
			5.0			-	5.1	7.1	1.0	8.0	
	tZH	15pF	3.3	RL=1kΩ	-	5.4	8.0	1.0	9.5	ns	
			5.0		-	3.6	5.1	1.0	6.0		
		50pF	3.3			-	7.9	11.5	1.0	13.0	ns
			5.0			-	5.1	7.1	1.0	8.0	
Output Disable Time	tLZ	50pF	3.3	RL=1kΩ	-	9.5	13.2	1.0	15.0	ns	
			5.0		-	6.1	8.8	1.0	10.0		
	tHZ	50pF	3.3	RL=1kΩ	-	9.5	13.2	1.0	15.0	ns	
			5.0		-	6.1	8.8	1.0	10.0		
Output Pin Skew (Note)	tosLH	50pF	3.3		-	-	1.5	-	1.5	ns	
			5.0		-	-	1.0	-	1.0		
	tosHL	50pF	3.3		-	-	1.5	-	1.5	ns	
			5.0		-	-	1.0	-	1.0		
Input Capacitance	CIN	-	-		-	4	10	-	10	pF	
Output Capacitance	COUT	-	-		-	6	-	-	-	pF	
Power Dissipation Capacitance	Cpd	-	-		-	17	-	-	-	pF	

Note: tosLH and tosHL are the guaranteed parameters.

$$\text{tosLH} = |t_{\text{PLHm}} - t_{\text{PHLn}}|, \text{tosHL} = |t_{\text{PHLm}} - t_{\text{PLLn}}|$$

## ■ NOISE CHARACTERISTICS

(tr=tf=3ns)

PARAMETER	SYMBOL	CONDITIONS		Ta=25°C			UNITS	
		CL	Vcc(V)	MIN.	TYP.	MAX.		
Non Functional Output Maximum Dynamic VOL	VOLP	50pF	5.0		-	0.3	0.8	V
Non Functional Output Minimum Dynamic VOL	VOLV	50pF	5.0		-0.8	-0.3	-	V
Minimum Dnamic VIH	VIHD	50pF	5.0		-	-	3.5	V
Maximum Dnamic VIL	VILD	50pF	5.0		-	-	1.5	V

# XC74WL240ASR

## ■ DELAY TIME

- Test Circuit

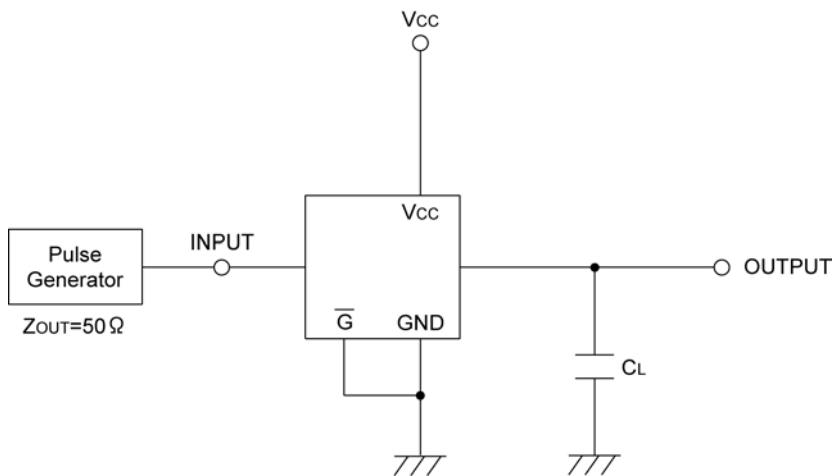

- Waveform

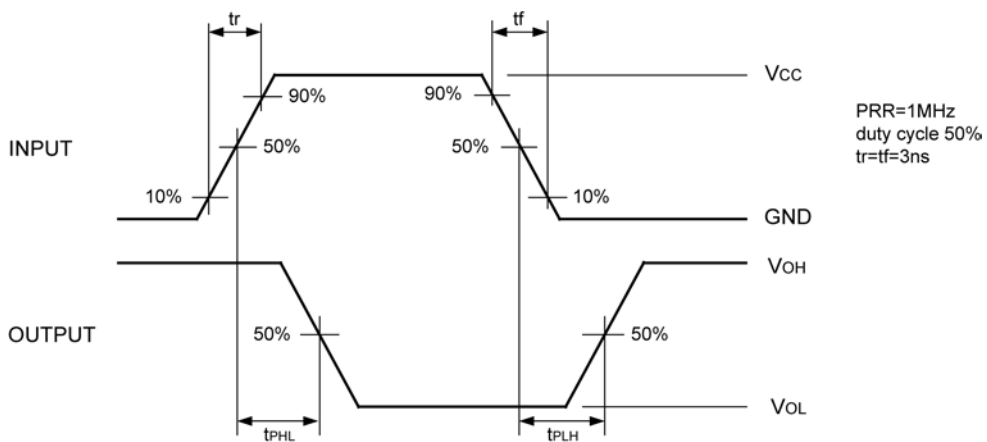

## ■ OUTPUT ENABLE TIME, OUTPUT DISABLE TIME

### • Test Circuit

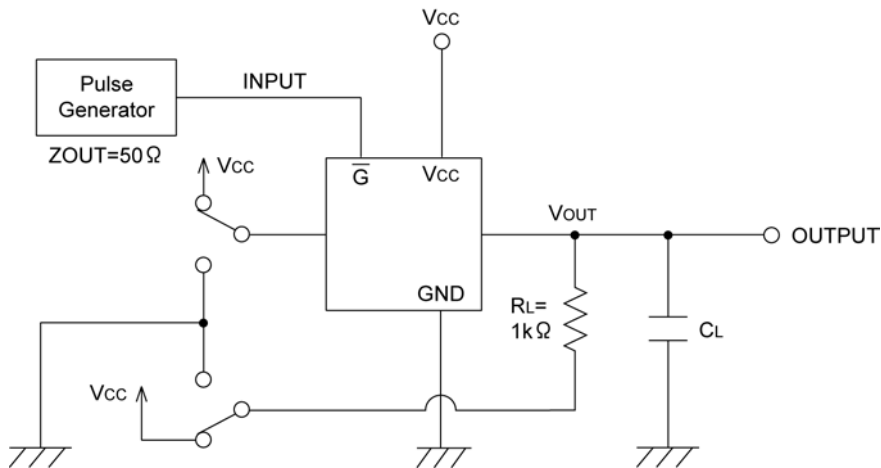

### • Waveform

