



Chipsmall Limited consists of a professional team with an average of over 10 year of expertise in the distribution of electronic components. Based in Hongkong, we have already established firm and mutual-benefit business relationships with customers from,Europe,America and south Asia,supplying obsolete and hard-to-find components to meet their specific needs.

With the principle of “Quality Parts,Customers Priority,Honest Operation,and Considerate Service”,our business mainly focus on the distribution of electronic components. Line cards we deal with include Microchip,ALPS,ROHM,Xilinx,Pulse,ON,Everlight and Freescale. Main products comprise IC,Modules,Potentiometer,IC Socket,Relay,Connector.Our parts cover such applications as commercial,industrial, and automotives areas.

We are looking forward to setting up business relationship with you and hope to provide you with the best service and solution. Let us make a better world for our industry!



Contact us

Tel: +86-755-8981 8866 Fax: +86-755-8427 6832

Email & Skype: info@chipsmall.com Web: www.chipsmall.com

Address: A1208, Overseas Decoration Building, #122 Zhenhua RD., Futian, Shenzhen, China



CMOS Logic

■ GENERAL DESCRIPTION

XC74WL74AASR is d-type flip flop manufactured using silicon gate CMOS processes. The small supply current, which is one of the features of the CMOS logic, gives way to high speed operations which enables LS-TTL.

With wave forming buffers connected internally, stabilized output can be achieved as the series offers high noise immunity.

As the series is integrated into a mini molded, MSOP-8B package, high density mounting is possible.

■ APPLICATIONS

- Palmtops
- Digital equipment

■ FEATURES

High Speed Operations : $f_{max} = 170\text{MHz}$ (TYP.) ($V_{CC}=5\text{V}$)

Operating Voltage Range : $2\text{V} \sim 5.5\text{V}$

Low Power Consumption: $1\ \mu\text{A}$ (MAX.)@ $T_a=25^\circ\text{C}$

CMOS Logic D-Type Flip Flop

Small Package : MSOP-8B

■ PIN CONFIGURATION

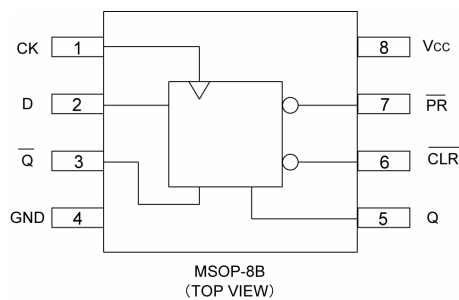

■ FUNCTIONS

INPUT				OUTPUT	
$\overline{\text{PR}}$	$\overline{\text{CLR}}$	CK	D	Q	$\overline{\text{Q}}$
L	H	X	X	H	L
H	L	X	X	L	H
L	L	X	X	H	H
H	H	\uparrow	H	H	L
H	H	\downarrow	L	L	H
H	H	\downarrow	X	Q_0	$\overline{Q_0}$

H=High level

L=Low level

X=Don't care

■ ABSOLUTE MAXIMUM RATINGS

Ta=-40°C~85°C

PARAMETER	SYMBOL	CONDITIONS	UNITS
Supply Voltage	V _{CC}	-0.5~+6.0	V
Input Voltage	V _{IN}	-0.5~+6.0	V
Output Voltage	V _{OUT}	-0.5~V _{CC} +0.5	V
Input Diode Current	I _{IK}	-20	mA
Output Diode Current	I _{OK}	±20	mA
Switch Output Current	I _{OUT}	±25	mA
V _{CC} ,GND Current	I _{CC} ,I _{GND}	±50	mA
Power Dissipation (Ta = 25°C)	P _d	300	mW
Storage Temperature Range	T _{stg}	-65~+150	°C

Note; Voltage is all ground standardized.

■ RECOMMENDED OPERATING CONDITIONS

PARAMETER	SYMBOL	CONDITIONS	UNITS
Supply Voltage	V _{CC}	2~5.5	V
Input Voltage	V _{IN}	0~5.5	V
Output Voltage	V _{OUT}	0~ V _{CC}	V
Operating Temperature Range	T _{opr}	-40~+85	°C
Input Rise and Fall Time	tr, tf	0~200 (V _{CC} =3.3V)	ns
		0~100 (V _{CC} =5V)	

■ DC ELECTRICAL CHARACTERISTICS

PARAMETER	SYMBOL	V _{CC} (V)	CONDITIONS	Ta=25°C			Ta=-40°C~85°C		UNITS	
				MIN.	TYP.	MAX.	MIN.	MAX.		
Input Voltage	V _{IH}	2.0		1.5	—	—	1.5	—	V	
		3.0		2.1	—	—	2.1	—		
		5.5		3.85	—	—	3.85	—		
	V _{IL}	2.0		—	—	0.5	—	0.5	V	
		3.0		—	—	0.9	—	0.9		
		5.5		—	—	1.65	—	1.65		
Output Voltage	V _{OH}	2.0	V _{IN} =V _{IL}	I _{OH} =-50 μA	1.9	2.0	—	1.9	—	V
		3.0			2.9	3.0	—	2.9	—	
		4.5			4.4	4.5	—	4.4	—	
		3.0		I _{OH} =-4mA	2.58	—	—	2.48	—	
		4.5		I _{OH} =-8mA	3.94	—	—	3.80	—	
	V _{OL}	V _{IN} =V _{IL} or V _{IH}	I _{OL} =50 μA	2.0	—	—	0.1	—	0.1	V
				3.0	—	—	0.1	—	0.1	
				4.5	—	—	0.1	—	0.1	
			3.0	I _{OL} =4mA	—	—	0.36	—	0.44	
			4.5	I _{OL} =8mA	—	—	0.36	—	0.44	
Input Current	I _{IN}	0~5.5	V _{IN} =V _{CC} or GND	-0.1	—	0.1	-1.0	1.0	μA	
Static Supply Current	I _{CC}	5.5	V _{IN} =V _{CC} or GND, I _{OUT} =0 μA	—	—	1.0	—	10.0	μA	

SWITCHING ELECTRICAL CHARACTERISTICS

(tr=tf=3ns)

PARAMETER	SYMBOL	CONDITIONS		Ta=25°C			Ta=-40°C~85°C		UNITS	
		CL	Vcc(V)	MIN.	TYP.	MAX.	MIN.	MAX.		
Delay Time (CK-Q, \bar{Q})	t _{PLH}	15pF	3.3		—	6.7	11.9	1.0	14.0	ns
			5.0		—	4.6	7.3	1.0	8.5	
		50pF	3.3		—	9.2	15.4	1.0	17.5	ns
			5.0		—	6.1	9.3	1.0	10.5	
	t _{PHL}	15pF	3.3		—	6.7	11.9	1.0	14.0	ns
			5.0		—	4.6	7.3	1.0	8.5	
		50pF	3.3		—	9.2	15.4	1.0	17.5	ns
			5.0		—	6.1	9.3	1.0	10.5	
Delay Time (PR, CLR-Q, \bar{Q})	t _{PLH}	15pF	3.3		—	7.6	12.3	1.0	14.5	ns
			5.0		—	4.8	7.7	1.0	9.0	
		50pF	3.3		—	10.1	15.8	1.0	18.0	ns
			5.0		—	6.3	9.7	1.0	11.0	
	t _{PHL}	15pF	3.3		—	7.6	12.3	1.0	14.5	ns
			5.0		—	4.8	7.7	1.0	9.0	
		50pF	3.3		—	10.1	15.8	1.0	18.0	ns
			5.0		—	6.3	9.7	1.0	11.0	
Minimum Set Up Time	ts(L)	—	3.3		6.0	—	—	7.0	—	ns
	ts(H)	—	5.0		5.0	—	—	5.0	—	
Minimum Hold Time	th(L)	—	3.3		2.0	—	—	2.0	—	ns
	th(H)	—	5.0		2.0	—	—	2.0	—	
Minimum Pulse Width (CK)	tw(L)	—	3.3		7.0	—	—	7.0	—	ns
	tw(H)	—	5.0		5.0	—	—	5.0	—	
Minimum Pulse Width (\bar{PR} , \bar{CLR})	Tw	—	3.3		7.0	—	—	7.0	—	ns
		—	5.0		5.0	—	—	5.0	—	
Minimum Removal Time (\bar{PR} , \bar{CLR})	trem	—	3.3		5.0	—	—	5.0	—	ns
		—	5.0		3.0	—	—	3.0	—	
Maximum Clock Frequency	fmax	15pF	3.3		80	125	—	70	—	MHz
			5.0		130	170	—	110	—	
	50pF	3.3		50	75	—	45	—	MHz	
		5.0		90	115	—	75	—		
Input Capacitance	C _{IN}	—	5.0	V _{IN} =V _{CC} or GND	—	4	10	—	10	pF
Power Dissipation Capacitance	C _{pd}	No Load, f=1MHz			—	9.3	—	—	—	pF

NOISE CHARACTERISTICS

(tr=tf=3ns)

PARAMETER	SYMBOL	CONDITIONS		Ta=25°C			UNITS	
		CL	Vcc(V)	MIN.	TYP.	MAX.		
Non Functional Output Maximum Dynamic V _{OL}	V _{OLP}	50pF	5.0		—	0.3	0.8	V
Non Functional Output Minimum Dynamic V _{OL}	V _{OLV}	50pF	5.0		-0.8	-0.3	—	V
Minimum Dynamic V _{IH}	V _{IHD}	50pF	5.0		—	—	3.5	V
Maximum Dynamic V _{IL}	V _{ILD}	50pF	5.0		—	—	1.5	V

XC74WL74AASR

TEST CIRCUIT

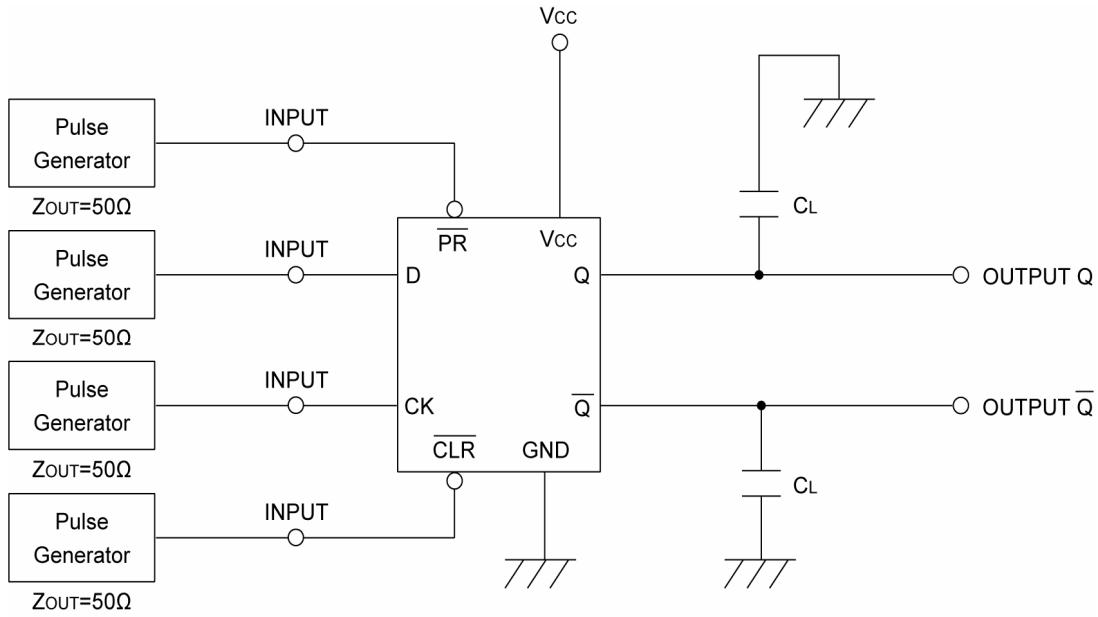

Notes: V_{OUT} =open when measuring supply current

WAVEFORM

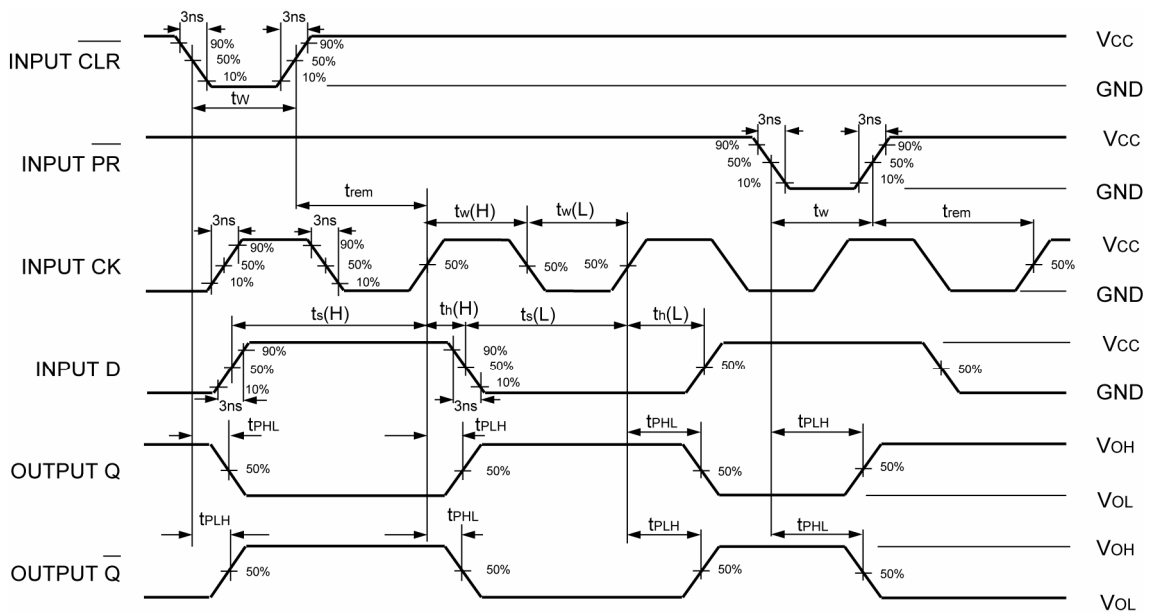

Notes: 1. Input Clock Frequency: 10MHz
2. D Input Frequency: 5MHz

1. The products and product specifications contained herein are subject to change without notice to improve performance characteristics. Consult us, or our representatives before use, to confirm that the information in this catalog is up to date.
2. We assume no responsibility for any infringement of patents, patent rights, or other rights arising from the use of any information and circuitry in this catalog.
3. Please ensure suitable shipping controls (including fail-safe designs and aging protection) are in force for equipment employing products listed in this catalog.
4. The products in this catalog are not developed, designed, or approved for use with such equipment whose failure of malfunction can be reasonably expected to directly endanger the life of, or cause significant injury to, the user.
(e.g. Atomic energy; aerospace; transport; combustion and associated safety equipment thereof.)
5. Please use the products listed in this catalog within the specified ranges.
Should you wish to use the products under conditions exceeding the specifications, please consult us or our representatives.
6. We assume no responsibility for damage or loss due to abnormal use.
7. All rights reserved. No part of this catalog may be copied or reproduced without the prior permission of Torex Semiconductor Ltd.

TOREX SEMICONDUCTOR LTD.