



Chipsmall Limited consists of a professional team with an average of over 10 year of expertise in the distribution of electronic components. Based in Hongkong, we have already established firm and mutual-benefit business relationships with customers from,Europe,America and south Asia,supplying obsolete and hard-to-find components to meet their specific needs.

With the principle of “Quality Parts,Customers Priority,Honest Operation,and Considerate Service”,our business mainly focus on the distribution of electronic components. Line cards we deal with include Microchip,ALPS,ROHM,Xilinx,Pulse,ON,Everlight and Freescale. Main products comprise IC,Modules,Potentiometer,IC Socket,Relay,Connector.Our parts cover such applications as commercial,industrial, and automotives areas.

We are looking forward to setting up business relationship with you and hope to provide you with the best service and solution. Let us make a better world for our industry!



Contact us

Tel: +86-755-8981 8866 Fax: +86-755-8427 6832

Email & Skype: info@chipsmall.com Web: www.chipsmall.com

Address: A1208, Overseas Decoration Building, #122 Zhenhua RD., Futian, Shenzhen, China



1A Driver Transistor Built-In, Step-Up DC/DC Converters

☆GreenOperation Compatible

■ GENERAL DESCRIPTION

The XC9128/XC9129 series are synchronous step-up DC/DC converters with a 0.2Ω (TYP.) N-channel driver transistor and a synchronous 0.2Ω (TYP.) P-channel switching transistor built-in. A highly efficient and stable current can be supplied up to 1.0A by reducing ON resistance of the built-in transistors. With a high switching frequency of 1.2MHz, a small inductor is selectable making the series ideally suited for applications requiring low profile or space saving solutions. With the MODE pin, the series provides mode selection of PWM control or PFM/PWM automatic switching control. In the PWM/PFM automatic switching mode, the series switches from PWM to PFM to reduce switching loss when load current is small. When load current is large, the series switches automatically to the PWM mode so that high efficiency is achievable over a wide range of load conditions. The series also provides small output ripple from light to large loads by using the built-in circuit which enables the smooth transition between PWM and PFM. With an adaptor enable function of the XC9128 series, when a voltage higher than the input voltage is applied to the output, the input and the output become isolated making it possible for the IC to work in parallel with the likes of an AC adaptor.

■ APPLICATIONS

- Digital audio equipment
- Digital still cameras / Camcorders
- Computer Mouses
- Multi-function power supplies

■ FEATURES

High Efficiency, Large Current Step-Up Converter

| | |
|--|---|
| Output Current | : 150mA@ $V_{OUT}=3.3V$, $V_{IN}=0.9V$ 500mA@ $V_{OUT}=3.3V$, $V_{IN}=1.8V$ |
| Input Voltage Range | : 0.8V~6.0V |
| Output Voltage Setting Range | : 1.8V~5.3V (Externally set) Set up freely with a reference voltage supply of 0.45V ($\pm 0.010V$) & external components |
| Oscillation Frequency | : 1.2MHz (Fixed oscillation frequency accuracy $\pm 15\%$) |
| Input Current | : 1.0A |
| Maximum Current Limit Control | : 1.2A (MIN.), 2.0A (MAX.) : PWM, PWM/PFM control externally selectable |
| High Speed Transient Response | : 100mV @ $V_{OUT}=3.3V$, $V_{IN}=1.8V$, $I_{OUT}=10mA \rightarrow 100mA$ |
| Protection Circuits | : Thermal shutdown Integral latch method (Over current limit) |
| Soft-Start Time | : 5ms (TYP.) internally set |
| Ceramic Capacitor Compatible | |
| Adaptor Enable Function (XC9128 series) | |
| Flag Output (XC9128 series) | : Open-drain output |
| Operating Ambient Temperature | : -40°C ~ +85°C |
| Packages | : MSOP-10, USP-10B |
| Environmentally Friendly | : EU RoHS Compliant, Pb Free |

■ TYPICAL APPLICATION CIRCUIT

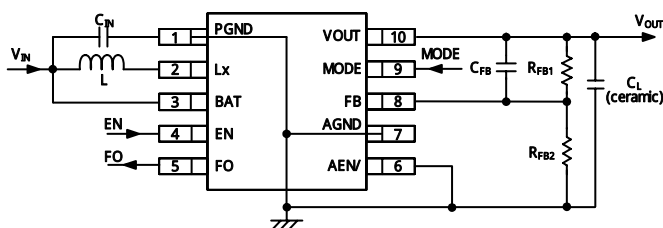

■ TYPICAL PERFORMANCE CHARACTERISTICS

- Efficiency vs. Output Current

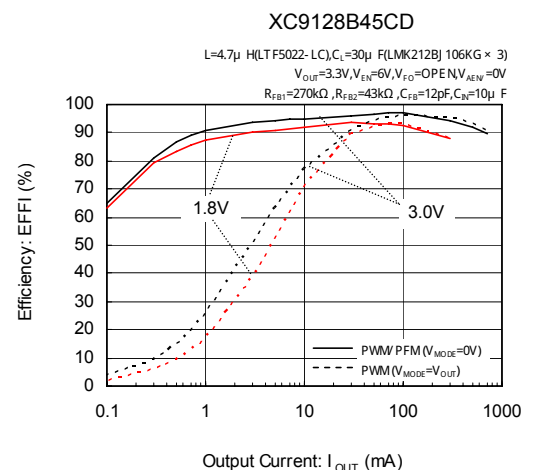

■ PIN CONFIGURATION

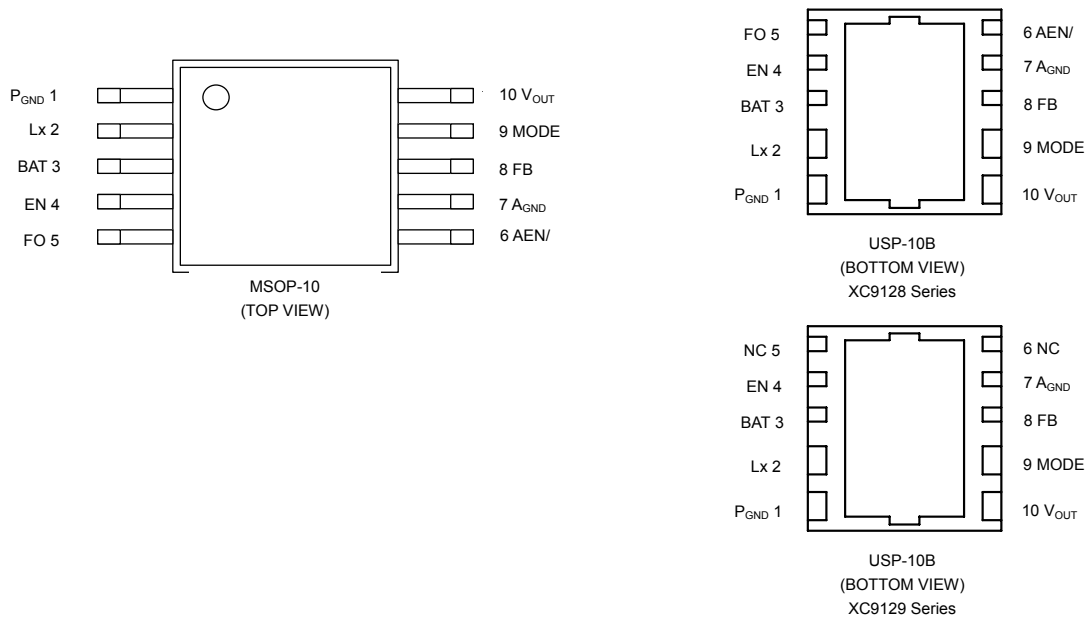

■ PIN ASSIGNMENT

| PIN NUMBER | | | PIN NAME | FUNCTION |
|------------|----------------------|----------------------|----------|---------------------------------|
| MSOP-10* | USP-10B* (XC9128) | USP-10B* (XC9129) | | |
| 1 | 1 | 1 | PGND | Power Ground |
| 2 | 2 | 2 | Lx | Output of Internal Power Switch |
| 3 | 3 | 3 | BAT | Battery Input |
| 4 | 4 | 4 | EN | Chip Enable |
| 5 | 5 | - | FO | Flag Output |
| 6 | 6 | - | AEN/ | Adaptor Enable |
| 7 | 7 | 7 | AGND | Analog Ground |
| 8 | 8 | 8 | FB | Output Voltage Monitor |
| 9 | 9 | 9 | MODE | Mode Switch |
| 10 | 10 | 10 | VOUT | Output Voltage |
| - | - | 5, 6 | NC | No Connection |

*For MSOP-10 and USP-10B packages, please short the GND pins (pins 1 and 7).

*The dissipation pad for the USP-10B package should be solder-plated following the recommended mount pattern and metal masking so as to enhance mounting strength and heat release. If the pad needs to be connected to other pins, it should be connected to the Ground pins (pins 1 and 7).

■ FUNCTION CHART

1. EN, AEN/ Pin Function

- XC9128 Series

| EN PIN | AEN/ PIN | FB PIN VOLTAGE | IC OPERATIONAL STATE | SOFT-START FUNCTION |
|--------|----------|-------------------------|--------------------------------|---------------------|
| L→H | L | - | Operation | Available |
| H | H→L | Lower than 0.45× 0.8V | Operation | Available |
| H | H→L | Higher than 0.45× 0.95V | Operation | Not Available |
| H | H | - | Step-Up Operation Shut-Down | - |
| L | L | - | Disable | - |
| L | H | - | Disable | - |

* Do not leave the EN and AEN/ Pins open.

- XC9129 Series

| EN PIN | IC OPERATIONAL STATE |
|--------|----------------------|
| H | Operation |
| L | Disable |

* Do not leave the EN Pin open.

2. MODE Pin Function

- XC9128/XC9129 Series

| MODE PIN | FUNCTION |
|----------|-------------------------------------|
| H | PWM Control |
| L | PWM/PFM Automatic Switching Control |

■ PRODUCT CLASSIFICATION

- Ordering Information

XC9128①②③④⑤⑥-⑦ ^(*) ... Adaptor Chip Enable Pin and Flag Output Pin are added

| DESIGNATOR | ITEM | SYMBOL | DESCRIPTION |
|---------------------|--------------------------|--------|--|
| ① | Integral Protection | B | With integral protection |
| | | D | Without integral protection |
| ②③ | Reference Voltage | 45 | Fixed reference voltage 0.45 V ②=4, ③=5 |
| ④ | Oscillation Frequency | C | 1.2MHz |
| ⑤⑥-⑦ ^(*) | Packages (Order Unit) | AR | MSOP-10 (1,000/Reel) |
| | | AR-G | MSOP-10 (1,000/Reel) |
| | | DR | USP-10B (3,000/Reel) |
| | | DR-G | USP-10B (3,000/Reel) |

XC9129①②③④⑤⑥-⑦ ^(*) ... Adaptor Chip Enable Pin and Flag Output Pin are not added

| DESIGNATOR | ITEM | SYMBOL | DESCRIPTION |
|---------------------|-------------------------|--------|---|
| ① | Integral Protection | B | With integral protection (under development) |
| | | D | Without integral protection |
| ②③ | Reference Voltage | 45 | Fixed reference voltage 0.45 V ②=4, ③=5 |
| ④ | Oscillation Frequency | C | 1.2MHz |
| ⑤⑥-⑦ ^(*) | Package (Order Unit) | DR | USP-10B (3,000/Reel) |
| | | DR-G | USP-10B (3,000/Reel) |

^(*) The "-G" suffix denotes Halogen and Antimony free as well as being fully EU RoHS compliant.

■ BLOCK DIAGRAM

• XC9128 Series

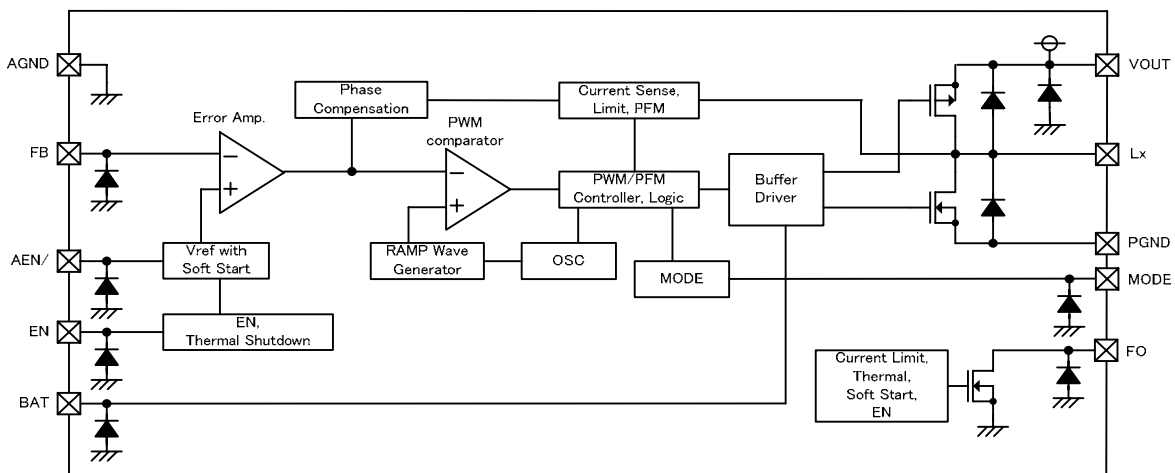

* XC9129 Series

The XC9129 series does not have AEN/ pin and FO pin.

■ ABSOLUTE MAXIMUM RATINGS

Ta=25°C

| PARAMETER | SYMBOL | RATINGS | UNITS | |
|---------------------------------|-------------------|-------------------------------|--------------------|----|
| V _{OUT} Pin Voltage | V _{OUT} | - 0.3 ~ 6.5 | V | |
| AEN/ Pin Voltage ⁽²⁾ | V _{AEN/} | - 0.3 ~ 6.5 | V | |
| FO Pin Voltage ⁽²⁾ | V _{FO} | - 0.3 ~ 6.5 | V | |
| FO Pin Current ⁽²⁾ | I _{FO} | 10 | mA | |
| FB Pin Voltage | V _{FB} | - 0.3 ~ 6.5 | V | |
| BAT Pin Voltage | V _{BAT} | - 0.3 ~ 6.5 | V | |
| MODE Pin Voltage | V _{MODE} | - 0.3 ~ 6.5 | V | |
| EN Pin Voltage | V _{EN} | - 0.3 ~ 6.5 | V | |
| L _x Pin Voltage | V _{Lx} | - 0.3 ~ V _{OUT} +0.3 | V | |
| L _x Pin Current | I _{Lx} | 2000 | mA | |
| Power Dissipation | MSOP-10 | Pd | 350 ⁽¹⁾ | mW |
| | USP-10B | | 150 | |
| Operating Ambient Temperature | T _{opr} | - 40 ~ +85 | °C | |
| Storage Temperature | T _{stg} | - 55 ~ +125 | °C | |

AGND, PGND is the standard voltage for all of voltages.

*1: When implemented on a PCB.

*2: The XC9129 series does not have AEN/ pin and FO pin. These pins are available only in the XC9128 series.

XC9128/XC9129 Series

ELECTRICAL CHARACTERISTICS

XC9128/XC9129 Series

Topr=25°C

| PARAMETER | SYMBOL | CONDITIONS | MIN. | TYP. | MAX. | UNITS | CIRCUIT |
|---|----------------------|--|------|---------------------|---------------------|-------|---------|
| Input Voltage | V _{IN} | - | - | - | 6.0 | V | - |
| FB Voltage | V _{FB} | V _{OUT} =V _{IN} =3.3V, V _{FO} =0V ^(*) Voltage to start oscillation during V _{FB} =0.46V → 0.44V | 0.44 | 0.45 | 0.46 | V | ④ |
| Output Voltage Setting Range | V _{OUTSET} | - | 1.8 | - | 5.3 | V | ① |
| Operation Start Voltage | V _{ST1} | Connect to external components, R _L =1kΩ | - | - | 0.8 | V | ① |
| | | Connect to external components, R _L =33Ω | - | - | 0.9 ^(*) | V | ① |
| Oscillation Start Voltage | V _{ST2} | Voltage to start oscillation during V _{IN} =0V → 1V, R _L =1kΩ | - | 0.8 | - | V | ① |
| Operation Hold Voltage | V _{HLD} | Connect to external components, R _L =1kΩ | - | 0.7 | - | V | ① |
| Supply Current 1 | I _{DD1} | V _{IN} = V _{OUT} = 3.3V, V _{FB} =0.45V×0.9 | - | 3 | 6 | mA | ② |
| Supply Current 2 (XC9128) | I _{DD2} | V _{IN} = V _{OUT} = 3.3V | - | 30 | 80 | μA | ② |
| Supply Current 2 (XC9129) | | V _{FB} =0.45V×1.1 (Oscillation stop), V _{MODE} =0V | - | 28 | 78 | | |
| Input Pin Current | I _{BAT} | V _{IN} = 3.3V, V _{OUT} = 1.8V, V _{EN} =0V | - | 2 | 10 | μA | ③ |
| Stand-by Current | I _{STB} | V _{IN} = V _{OUT} = 3.3V, V _{EN} =0V | - | 2 | 10 | μA | ② |
| Oscillation Frequency | f _{OSC} | V _{IN} = V _{OUT} = 3.3V, V _{FO} =0V ^(*) , V _{FB} =0.45V×0.9 | 1.02 | 1.20 | 1.38 | MHz | ④ |
| Maximum Duty Cycle | MAXDTY | V _{IN} = V _{OUT} = 3.3V, V _{FO} =0V ^(*) , V _{FB} =0.45V×0.9 | 85 | 92 | 96 | % | ④ |
| Minimum Duty Cycle | MINDTY | V _{IN} = V _{OUT} = 3.3V, V _{FO} =0V ^(*) , V _{FB} =0.45V×1.1 | - | - | 0 | % | ④ |
| PFM Switching Current | I _{PFM} | Connect to external components, V _{MODE} =0V, R _L =330Ω | - | 250 | 400 | mA | ① |
| Efficiency ^(*) | EFFI | Connect to external components, R _L =33Ω | - | 93 | - | % | ① |
| Lx SW "Pch" ON Resistance | R _{LxP} | V _{IN} =V _{Lx} =V _{OUT} +50mV, V _{FB} =0.45V×1.1 ^(*) | - | 0.20 | 0.35 ^(*) | Ω | ⑤ |
| Lx SW "Nch" ON Resistance | R _{LxN} | V _{IN} =V _{OUT} =3.3V, Lx =50mV ^(*) | - | 0.20 ^(*) | 0.35 ^(*) | Ω | ⑦ |
| Lx Leak Current | I _{LXL} | V _{IN} =V _{OUT} = V _{Lx} , V _{FB} =0V | - | 1 | - | μA | ⑤ |
| Current Limit ^(*) | I _{LIM} | V _{OUT} >2.5V | 1.2 | 1.5 | 2.0 | A | ① |
| Integral Latch Time (XC9128) ^(*) | t _{LAT} | Time to stop oscillation during R _L =33Ω → 3.3Ω, V _{FO} =L → H | - | 3.5 | - | ms | ① |
| Integral Latch Time (XC9129) ^(*) | | Time to stop oscillation during R _L =33Ω → 3.3Ω | | | | | |
| Soft-Start Time 1 | t _{SS1} | Time to start oscillation during V _{EN} =0V → V _{IN} at V _{IN} = V _{OUT} = 3.3V, V _{FO} =0V, V _{FB} =0.45V×0.95 | 1.7 | 5.3 | 10.5 | ms | ④ |
| Soft-Start Time 2 ^(*) | t _{SS2} | V _{IN} = V _{OUT} = 3.3V, V _{FO} =0V, V _{FB} =0.45V×0.95 Time to start oscillation during V _{AEN} =V _{IN} →0V. | - | 0.02 | 0.04 | ms | ④ |
| Soft-Start Time 3 ^(*) | t _{SS3} | V _{IN} = V _{OUT} = 3.3V, V _{FO} =0V, V _{FB} =0.45V×0.8 Time to start oscillation during V _{AEN} =V _{IN} →0V | 1.7 | 5.3 | 10.5 | ms | ④ |
| Thermal Shutdown Temperature | T _{TSD} | - | - | 150 | - | °C | - |
| Hysteresis Width | T _{HYS} | - | - | 20 | - | °C | - |
| Output Voltage Drop Protection ^(*) | V _{LVP} | V _{IN} = 3.3V Voltage to stop oscillation during V _{OUT} =1.56V→1.3V | 1.3 | 1.48 | 1.56 | V | ⑥ |
| FO Output Current ^(*) | I _{FO_OUT} | V _{IN} = V _{OUT} = 3.3V, V _{FO} =0.25V | 1.3 | 1.7 | 2.2 | mA | ④ |
| FO Leakage Current ^(*) | I _{FO_Leak} | V _{IN} = V _{OUT} = 3.3V, V _{EN} =0V, V _{FO} =1V | - | 0 | 1 | μA | ④ |

■ ELECTRICAL CHARACTERISTICS (Continued)

● XC9128/XC9129 Series (Continued)

Topr=25 °C

| PARAMETER | SYMBOL | CONDITIONS | MIN. | TYP. | MAX. | UNITS | CIRCUIT |
|---------------------------------|--------|---|------|------|------|---------|---------|
| EN "H" Voltage | VENH | $V_{IN}=V_{OUT}=3.3V, V_{FO}=0V$ ⁽⁸⁾ Voltage to start oscillation during $V_{FB}=0.45V \times 0.9, V_{EN}=0.2V \rightarrow 0.65V$ | 0.65 | - | 6.0 | V | ④ |
| EN "L" Voltage | VENL | $V_{IN}=V_{OUT}=3.3V, V_{FO}=0V$ ⁽⁸⁾ Voltage to stop oscillation during $V_{FB}=0.45V \times 0.9,$ $V_{EN}=0.65V \rightarrow 0.20V$ | - | - | 0.2 | V | ④ |
| MODE "H" Voltage | VMODEH | $R_L=330\Omega$, Voltage operates at PWM control | 0.65 | - | 6.0 | V | ① |
| MODE "L" Voltage | VMODEL | $R_L=330\Omega$, Voltage operates at PFM control | AGND | - | 0.2 | V | ① |
| AEN/ Voltage ⁽⁷⁾ | VAEN/ | $V_{IN}=V_{OUT}=3.3V, V_{FO}=0V$ Voltage to start oscillation during $V_{AEN/}=0.9V \rightarrow 0.7V$ | 0.7 | 0.8 | 0.9 | V | ④ |
| EN "H" Current | IENH | $V_{IN}=V_{OUT}=V_{FB}=V_{EN}=6.0V$ | - | - | 0.1 | μA | ② |
| EN "L" Current | IENL | $V_{IN}=V_{OUT}=V_{FB}=6.0V, V_{EN}=0V$ | -0.1 | - | - | μA | ② |
| MODE "H" Current | IMODEH | $V_{IN}=V_{OUT}=V_{FB}=V_{MODE}=6.0V$ | - | - | 0.1 | μA | ② |
| MODE "L" Current | IMODEL | $V_{IN}=V_{OUT}=V_{FB}=6.0V, V_{MODE}=0V$ | -0.1 | - | - | μA | ② |
| AEN/ "H" Current ⁽⁷⁾ | IAEN/H | $V_{IN}=V_{OUT}=V_{FB}=V_{AEN/}=6.0V$ | - | - | 0.1 | μA | ② |
| AEN/ "L" Current ⁽⁷⁾ | IAEN/L | $V_{IN}=V_{OUT}=6.0V, V_{EN}=0V, V_{AEN/}=0V$ | -0.1 | - | - | μA | ② |
| FB "H" Current | IFBH | $V_{IN}=V_{OUT}=V_{FB}=6.0V$ | - | - | 0.1 | μA | ② |
| FB "L" Current | IFBL | $V_{IN}=V_{OUT}=6.0V, V_{FB}=0V$ | -0.1 | - | - | μA | ② |

Test Conditions: For the Circuit No.1, unless otherwise stated, $V_{IN}=1.8V, V_{EN}=V_{MODE}=V_{FO}=3.3V, V_{AEN/}=0V$ ⁽⁸⁾
 For the Circuit No.2, unless otherwise stated, $V_{IN}=1.8V, V_{FB}=0V, V_{EN}=V_{MODE}=3.3V, V_{AEN/}=0V$ ⁽⁸⁾
 For the Circuit No.3, unless otherwise stated, $V_{IN}=1.8V, V_{OUT}=V_{EN}=V_{MODE}=3.3V, V_{FB}=0V$
 For the Circuit No.4, unless otherwise stated, $V_{IN}=1.8V, V_{FB}=0V, V_{EN}=V_{MODE}=V_{pull}=V_{FO}=3.3V, V_{AEN/}=0V$ ⁽⁸⁾
 For the Circuit No.5, unless otherwise stated, $V_{IN}=3.3V, V_{AEN/}=0V$ ⁽⁸⁾
 For the Circuit No.6, unless otherwise stated, $V_{EN}=V_{MODE}=V_{pull}=V_{FO}=3.3V, V_{FB}=0V$ ⁽⁸⁾
 For the Circuit No.7, unless otherwise stated, $V_{EN}=V_{MODE}=3.3V$

External Components: For the Circuit No.1, $R_{FB1}=270k\Omega, R_{FB2}=43k\Omega, C_{FB}=12pF, L=4.7\mu H$ (LTF5022 TDK), $C_{L1}=22\mu F$ (ceramic), $C_{L2}=10\mu F$ (ceramic), $C_{IN}=10\mu F$ (ceramic)
 For the Circuit No.2,3, $C_{IN}=1\mu F$ (ceramic)
 For the Circuit No.4,6, $C_{IN}=1\mu F$ (ceramic), $R_{pull}=300\Omega$
 For the Circuit No.5, $C_{IN}=1\mu F$ (ceramic), $C_{OUT}=1\mu F$ (ceramic)
 For the Circuit No.7, $C_{IN}=1\mu F$ (ceramic), $C_{OUT}=1\mu F$ (ceramic), SBD=XBS304S17 (TOREX), $R_{pull}=0.5\Omega$

¹: Designed value

²: Efficiency = {(output voltage) X (output current)} ÷ {(input voltage) X (input current)} X 100

³: L_x SW "P-ch" ON resistance = $(V_{Lx}-V_{OUT}$ pin test voltage) ÷ 100mA

⁴: Testing method of L_x SW "N-ch" ON resistance is stated at test circuits.

⁵: Current flowing through the Nch driver transistor is limited.

⁶: The XC9128D/XC9129D series does not have integral latch protection and V_{LVP} function.
This is only available with the XC9128B/XC9129B series.

⁷: The XC9129 series does not have FO and AEN/ pins. These pins are only available in the XC9128 series.

⁸: The XC9129 series does not have FO and AEN/ pins. The AEN/FO functions are only effective for the test of the XC9128 series.

TYPICAL APPLICATION CIRCUIT

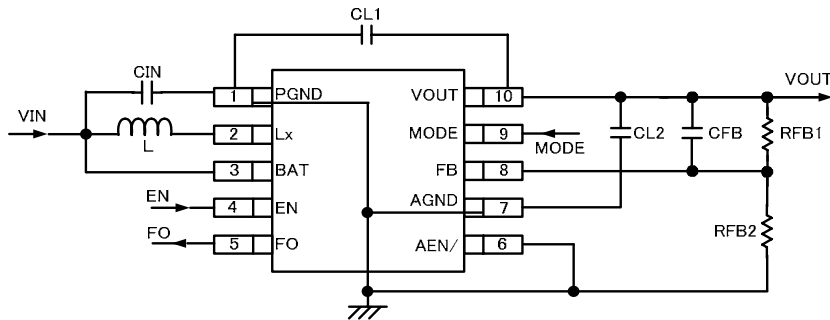

<Output Voltage Setting>

Output voltage can be set by adding external split resistors. Output voltage is determined by the following equation, based on the values of RFB1 and RFB2. The sum of RFB1 and RFB2 should normally be 500kΩ or less.

$$V_{OUT} = 0.45 \times (R_{FB1} + R_{FB2}) / R_{FB2}$$

The value of CFB, speed-up capacitor for phase compensation, should be $f_{ZFB} = 1 / (2 \times \pi \times C_{FB1} \times R_{FB1})$ which is in the range of 10 kHz to 60 kHz. Adjustments are depending on application, inductance (L), load capacitance (CL) and dropout voltage.

[Example of calculation]

When RFB1=270kΩ, RFB2=43kΩ,

$$V_{OUT1} = 0.45 \times (270k + 43k) / 43k = 3.276V$$

[Typical example]

| VOUT (V) | RFB1 (kΩ) | RFB2 (kΩ) | CFB (pF) |
|----------|-----------|-----------|----------|
| 1.8 | 300 | 100 | 10 |
| 2.5 | 270 | 59 | 12 |
| 3.3 | 270 | 43 | 12 |
| 5.0 | 180 | 17.8 | 15 |

[External Components]

1.2MHz:

- L : 4.7μ H (LTF5022-4R7-LC TDK)
- : 4.7μ H (CDRH4D28C-4R7N SUMIDA)
- CL1 : 22μ F (ceramic)
- CL2 : 10μ F (ceramic)
- CIN : 10μ F (ceramic)

* CL1 should be selected in 10μ F or higher.

Capacitance CL1 + CL2 is recommended 30μ F or higher. (Ceramic capacitor compatible)

If CL1 is lower than 10μ F, operation may be unstable.

In case of the usage CL1 + CL2 < 30μ F, output ripple may increase so that we recommend that you fully check actual performance on the board.

* If using Tantalum or Electrolytic capacitors please be aware that ripple voltage will be higher due to the larger ESR (Equivalent Series Resistance) values of those types of capacitors. Please also note that the IC's operation may become unstable with such capacitors so we recommend that you fully check actual performance.

■ OPERATIONAL EXPLANATION

The XC9128/XC9129 series consists of a reference voltage source, ramp wave circuit, error amplifier, PWM comparator, phase compensation circuit, N-channel driver transistor, P-channel synchronous rectification switching transistor and current limiter circuit. The error amplifier compares the internal reference voltage with the FB pin feed back voltage via resistors RFB1 and RFB2. Phase compensation is performed on the resulting error amplifier output, to input a signal to the PWM comparator to determine the turn-on time of the N-channel driver transistor during PWM operation. The PWM comparator compares, in terms of voltage level, the signal from the error amplifier with the ramp wave from the ramp wave circuit, and delivers the resulting output to the buffer driver circuit to cause the Lx pin to output a switching duty cycle. This process is continuously performed to ensure stable output voltage. The current feedback circuit monitors the N-channel driver transistor's turn-on current for each switching operation, and modulates the error amplifier output signal to provide multiple feedback signals. This enables a stable feedback loop even when a low ESR capacitor, such as a ceramic capacitor, is used, ensuring stable output voltage.

<Reference Voltage Source>

The source provides the reference voltage to ensure stable output of the DC/DC converter.

<Ramp Wave Circuit>

The ramp wave circuit determines switching frequency. The frequency is fixed internally at 1.2MHz. The Clock generated is used to produce ramp waveforms needed for PWM operation, and to synchronize all the internal circuits.

<Error Amplifier>

The error amplifier is designed to monitor output voltage. The amplifier compares the reference voltage with the feedback voltage divided by the internal resistors (RFB1 and RFB2). When the FB pin is lower than the reference voltage, output voltage of the error amplifier increases. The gain and frequency characteristics of the error amplifier are optimized internally.

< Maximum Current Limit>

The current limiter circuit monitors the maximum current flowing through the N-channel driver transistor connected to the Lx pin, and features a combination of the current limit and latch function.

- ①When the driver current is greater than a specific level (equivalent to peak coil current), the maximum current limit function starts to operate and the pulses from the Lx pin turn off the N-channel driver transistor at any given time.
- ②When the driver transistor is turned off, the limiter circuit is then released from the maximum current limit detection state.
- ③At the next pulse, the driver transistor is turned on. However, the transistor is immediately turned off in the case of an over current state.
- ④ When the over current state is eliminated, the IC resumes its normal operation.

The XC9128B/XC9129B series waits for the over current state to end by repeating the steps ① through ③. If an over current state continues for several ms and the above three steps are repeatedly performed, the IC performs the function of latching the OFF state of the N-channel driver transistor, and goes into operation suspension mode. After being put into suspension mode, the IC can resume operation by turning itself off once and then re-starting via the EN pin, or by restoring power to the V_{IN} pin.

The XC9128D/XC9129D series does not have this latch function, so operation steps ① through ③ repeat until the over current state ends.

Integral latch time may be released from a over current detection state because of the noise. Depending on the state of a substrate, it may result in the case where the latch time may become longer or the operation may not be latched. Please locate an input capacitor as close as possible.

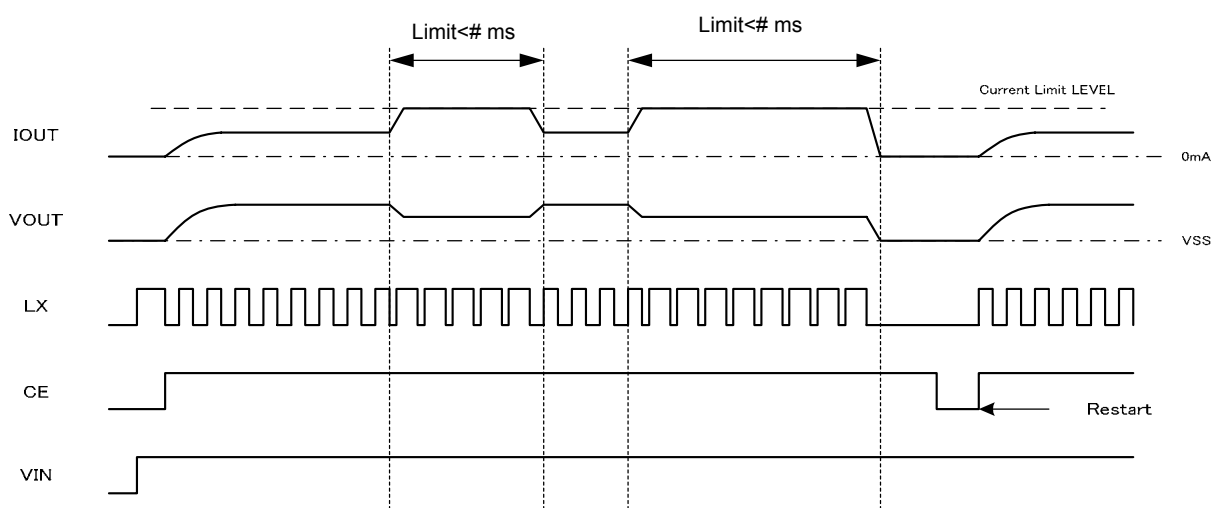

■ OPERATIONAL EXPLANATION (Continued)

<Thermal Shutdown>

For protection against heat damage, the thermal shutdown function monitors chip temperature. When the chip's temperature reaches 150°C (TYP.), the thermal shutdown circuit starts operating and the driver transistor will be turned off. At the same time, the output voltage decreases. When the temperature drops to 130°C (TYP.) after shutting off the current flow, the IC performs the soft start function to initiate output startup operation.

<MODE>

The MODE pin operates in PWM mode by applying a high level voltage and in PFM/PWM automatic switching mode by applying a low level voltage.

<Shut-Down>

The IC enters chip disable state by applying low level voltage to the EN pin. At this time, the P-ch synchronous switching transistor turns on when $V_{IN} > V_{OUT}$ and vice versa the transistor turns off when $V_{IN} < V_{OUT}$.

<Adaptor Enable>

While the XC9128 series using step-up DC/DC converters in parallel with an added power source such as AC adaptors, the circuit needs the step-up DC/DC converter to be transient-efficient for sustaining output voltage in case the added power source runs down. The AEN/ pin voltage determines whether the added power source is supplied or not so that high-speed following operation is possible. The IC starts operating although the driver transistor is off when a high level voltage is applied to the AEN/ pin after a high level voltage is also applied to the EN pin. If the AEN/ pin voltage changes from high level to low level while the EN pin sustains a high level voltage, the step-up operation starts with high-speed following mode (without soft-start). The XC9129 series does not have adaptor enable function.

<Error Flag >

For the XC9128 series, the FO pin becomes high impedance during over current state, over temperature state, soft-start period, and shut-down period.

The XC9129 series does not have flag out function.

■ NOTE ON USE

1. Please do not exceed the stated absolute maximum ratings values.
2. The DC/DC converter / controller IC's performance is greatly influenced by not only the IC's characteristics, but also by those of the external components. Care must be taken when selecting the external components.
3. Make sure that the PCB GND traces are as thick as possible, as variations in ground potential caused by high ground currents at the time of switching may result in instability of the IC.
4. Please mount each external component as close to the IC as possible and use thick, short traces to reduce the circuit impedance.
5. When the device is used in high step-up ratio, the current limit function may not work during excessive load current. In this case, the maximum duty cycle limits maximum current.
6. When the adaptor enable function is used in the below circuit, please use a diode with low reverse bias current. The sum of R_{AEN1} 's and R_{AEN2} 's resistance should be set to manage the reverse bias current.

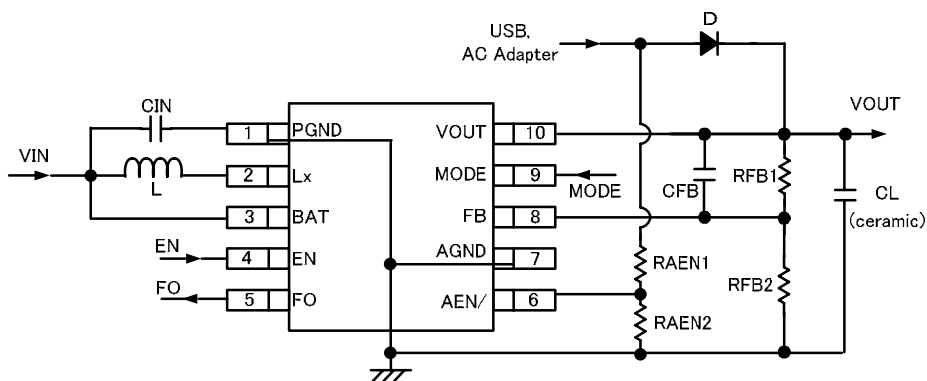

■ NOTE ON USE (Continued)

7. P-ch synchronous switching transistor operation

The parasitic diode of the P-ch synchronous transistor is placed between Lx (anode) and V_{OUT} (cathode), so that the power line can not be turned off from Lx to V_{OUT}. On the other hand, the power line switch from V_{OUT} to Lx is shown in the table below.

• XC9128 Series

| EN Pin | AEN/Pin | P-channel Synchronous Switch Transistor Operation |
|--------|---------|---|
| H | H | OFF |
| H | L | Switching |
| L | H | OFF |
| L | L | Undefined |

• XC9129 Series

| EN Pin | P-channel Synchronous Switch Transistor Operation |
|--------|---|
| H | Switching |
| L | Undefined |

With the XC9128B/XC9129B series, when step-up operation stops as a result of the latch condition working when the maximum current limit level is reached, the synchronous P-channel transistor will remain ON.

8. The maximum current limiter controls the limit of the N-channel driver transistor by monitoring current flow. This function does not limit the current flow of the P-channel synchronous transistor.
9. The integral latch time of the XC9128B/XC9129B series could be released from the maximum current detection state as a result of board mounting conditions. This may extend integral latch time or the level required for latch operation to function may not be reached. Please connect the output capacitor as close to the IC as possible.
10. With the XC9128B/XC9129B series, when the EN pin is left open or applied in the range of 0.2V ~ 0.65V, the integral latch or the V_{LVP} may not be able to release. Please make sure that the EN pin voltage is less than 0.2V or more than 0.65V, or use the XC9128D/XC9129D series which does not have the integral latch and the LVP functions.
11. With the XC9128B/XC9129B series, please make the V_{OUT} pin voltage become more than 1.5V within the soft-start time, otherwise the V_{LVP} is detected. Also, the operation may become unstable, please test and verify the operation in the actual circuits thoroughly before use.
12. When used in small step-up ratios, the device may skip pulses during PWM control mode.

TEST CIRCUITS *1

< Circuit No.1 >

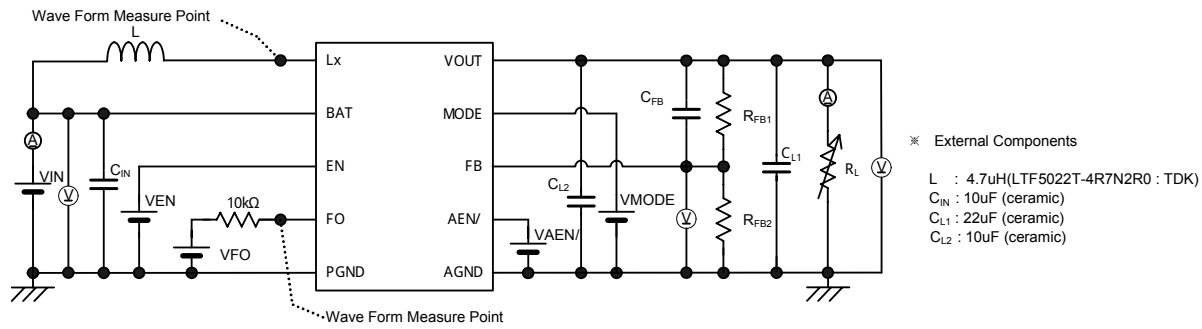

< Circuit No.2 >

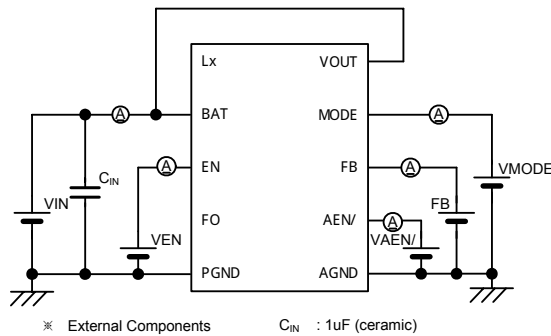

< Circuit No.3 >

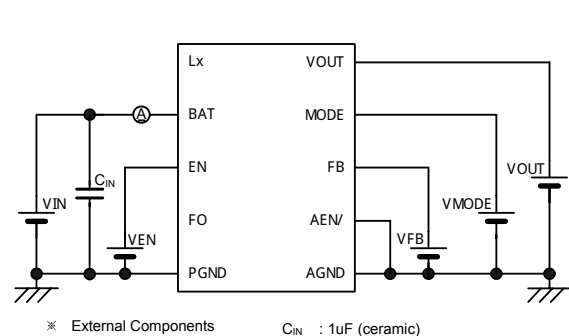

< Circuit No.4 >

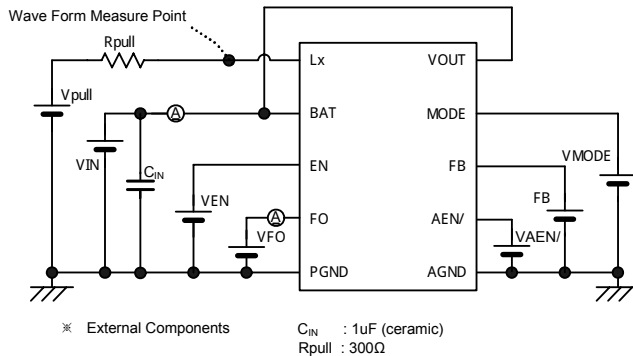

< Circuit No.5 >

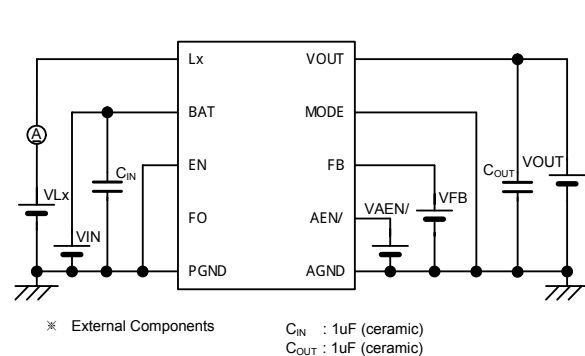

< Circuit No.6 >

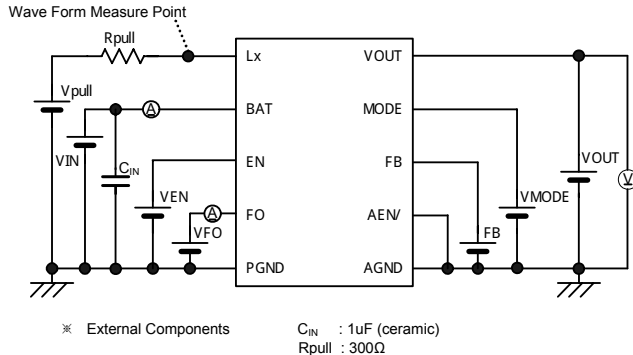

< Circuit No.7 >

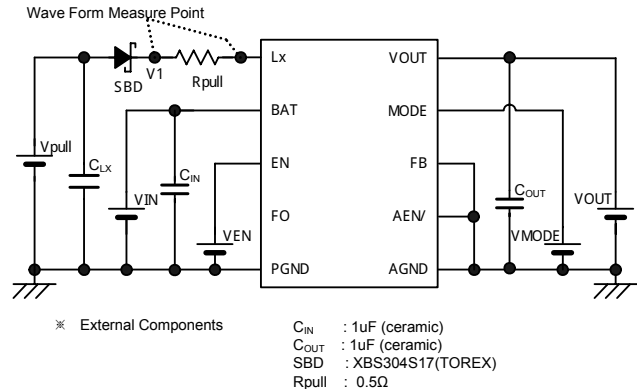

Measurement method for ON resistance of the Lx switch

Using the layout of circuit No.7 above, set the L_x pin voltage to 50mV by adjusting the V_{pull} voltage whilst the N-ch driver transistor is turned on. Then, measure the voltage difference between both ends of R_{pull}. ON Resistance is calculated by using the following formula:

$$R_{LxN} = 0.05 \div ((V1 - 0.05) \div 0.5)$$

where V1 is a voltage between SBD and R_{pull}. L_x pin voltage and V1 are measured by an oscilloscope.

*1: The XC9129 series does not have the AEN/ pin and the FO pin. When the XC9129 series is measured, the FO and AEN pins are not effective in the above mentioned test circuits, they are NC.

■ **TYPICAL PERFORMANCE CHARACTERISTICS**

(1) Efficiency vs. Output Current

XC9128 (V_{OUT}=3.3V)

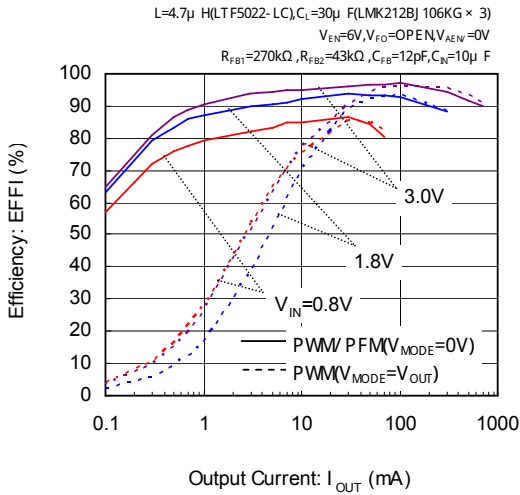

XC9128 (V_{OUT}=5.0V)

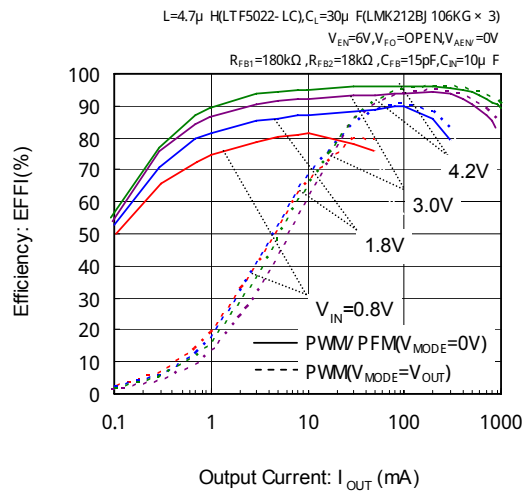

XC9128 (V_{OUT}=1.8V)

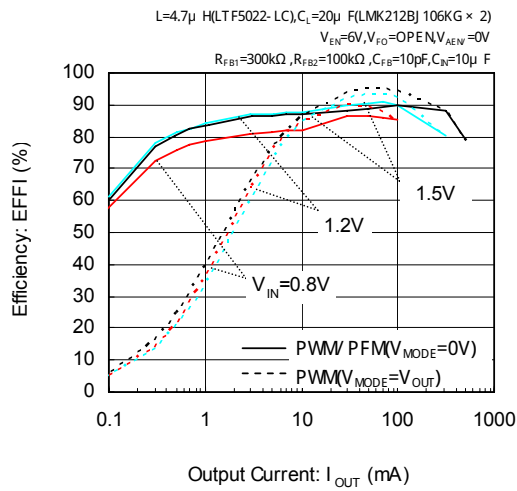

TYPICAL PERFORMANCE CHARACTERISTICS (Continued)

(2) Output Voltage vs. Output Current

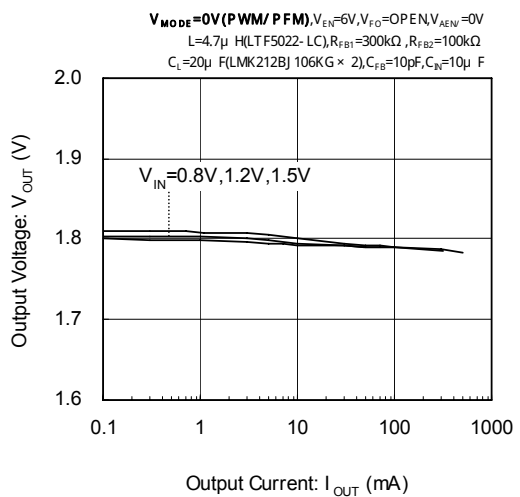
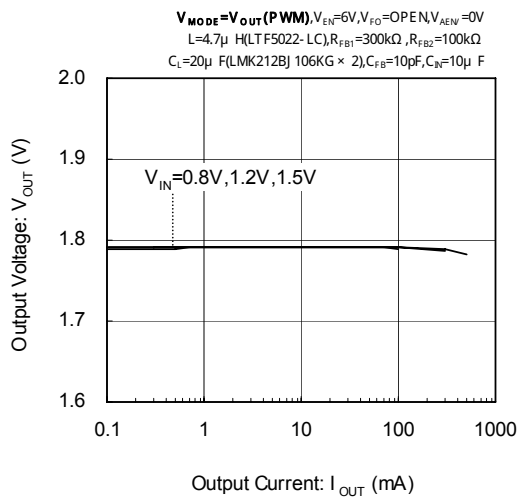
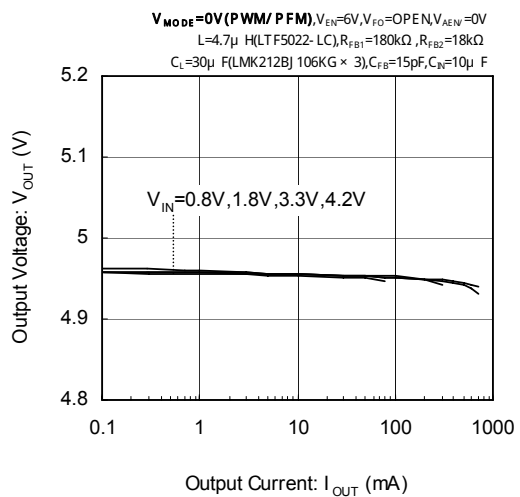
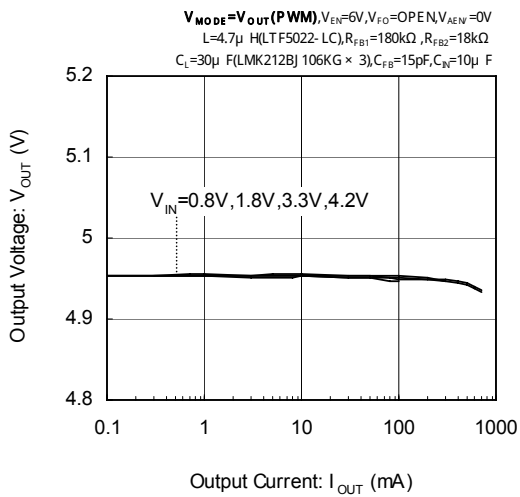
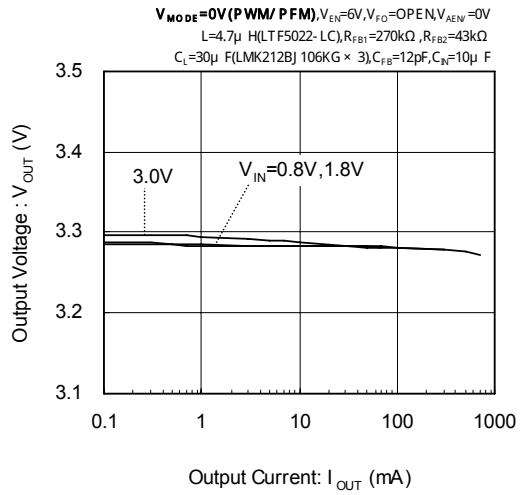
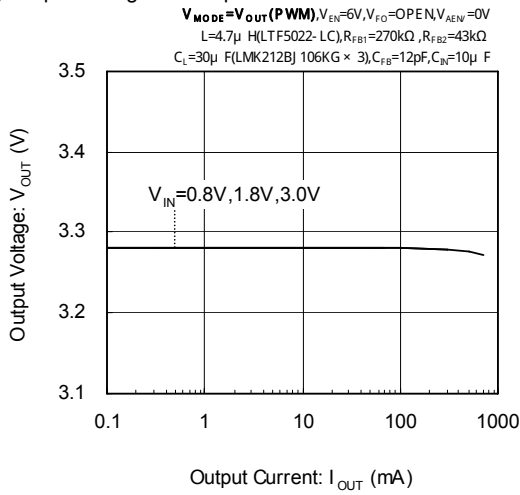

■ **TYPICAL PERFORMANCE CHARACTERISTICS (Continued)**

(3) Ripple Voltage vs. Output Current

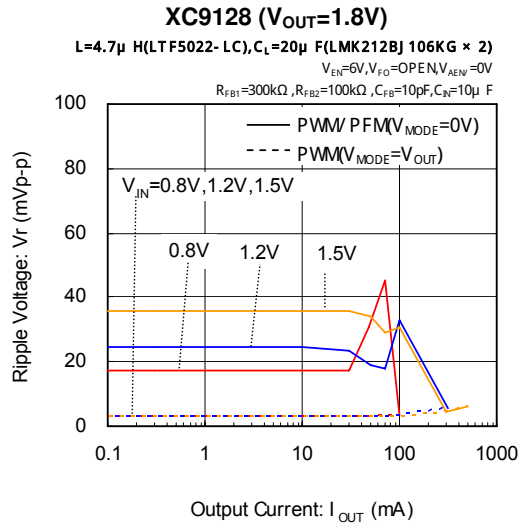
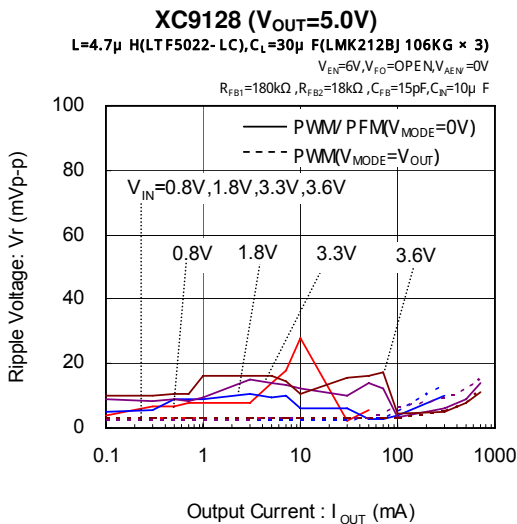
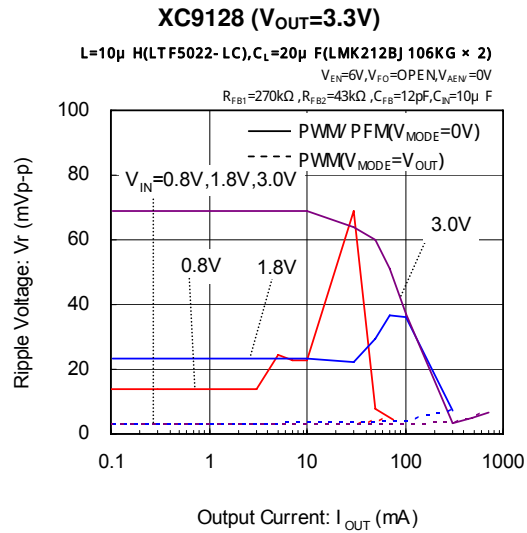
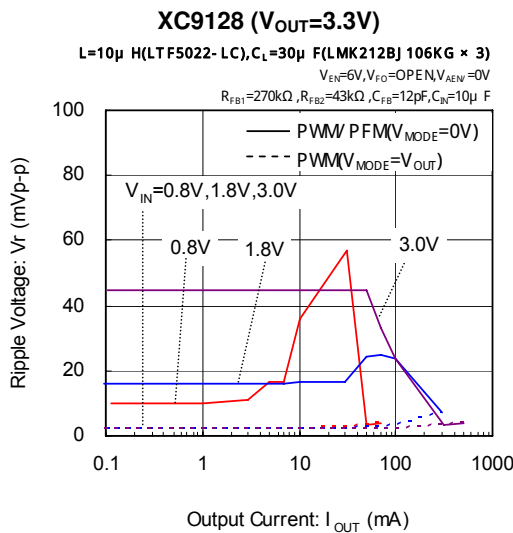
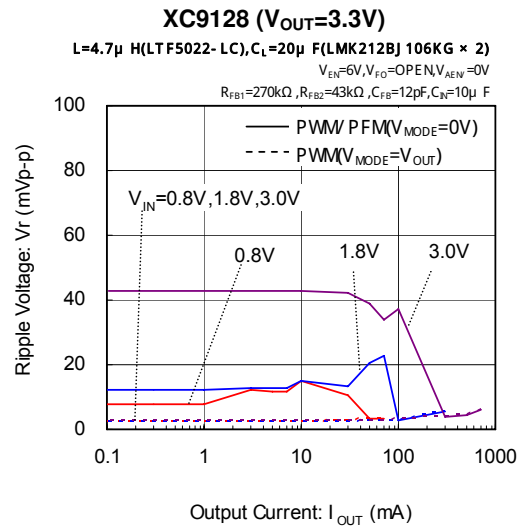
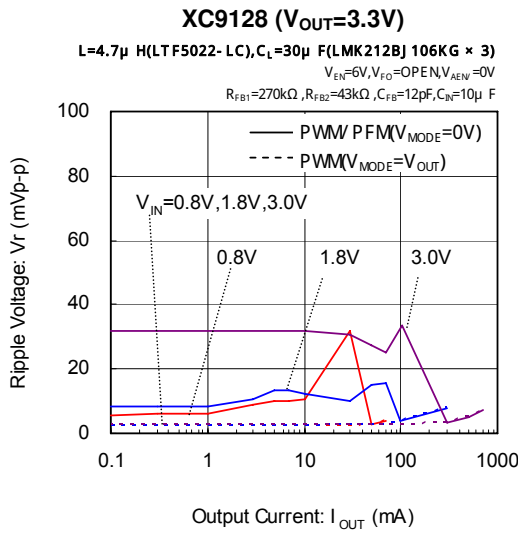

■ TYPICAL PERFORMANCE CHARACTERISTICS (Continued)

(4) Supply Current 1 vs. Ambient Temperature

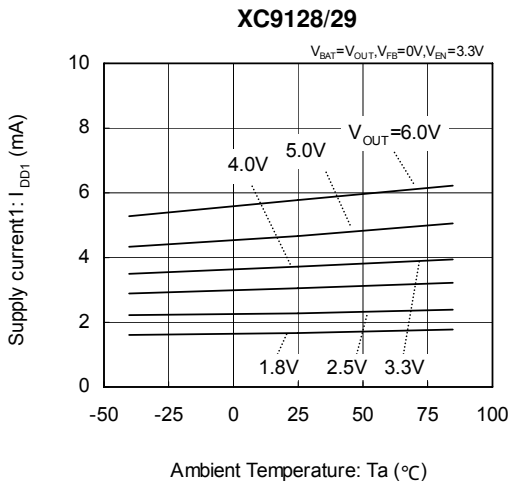

(5) Supply Current 1 vs. Output Voltage

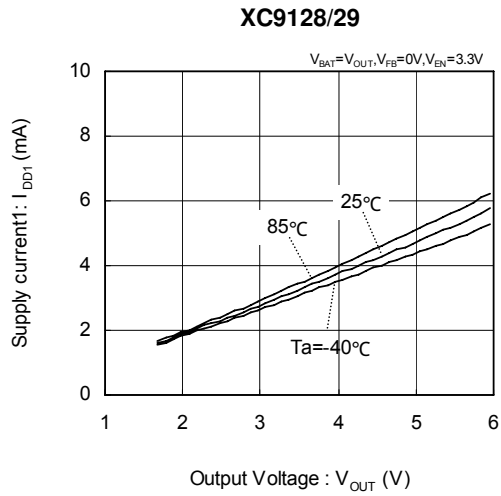

(6) Supply Current 2 vs. Ambient Temperature

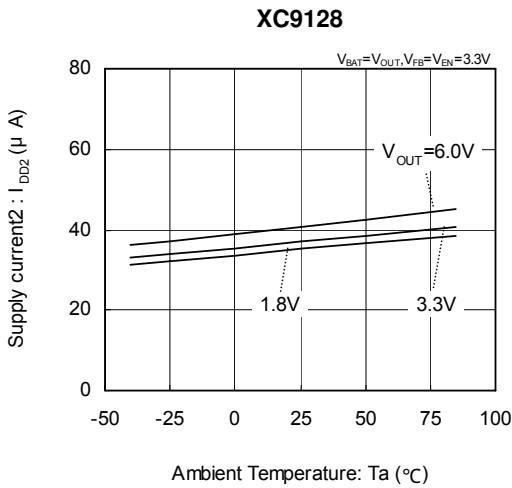

(7) Supply Current 2 vs. Output Voltage

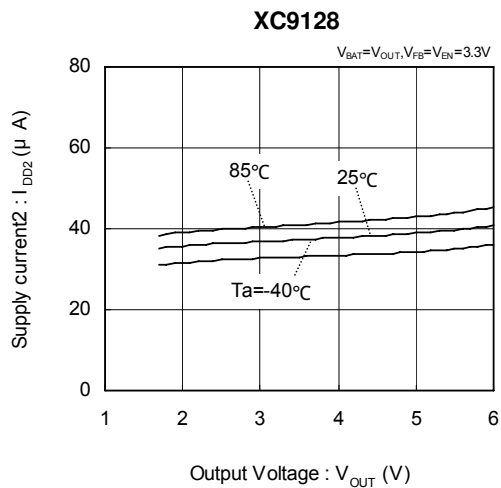

(8) Standby Current vs. Ambient Temperature

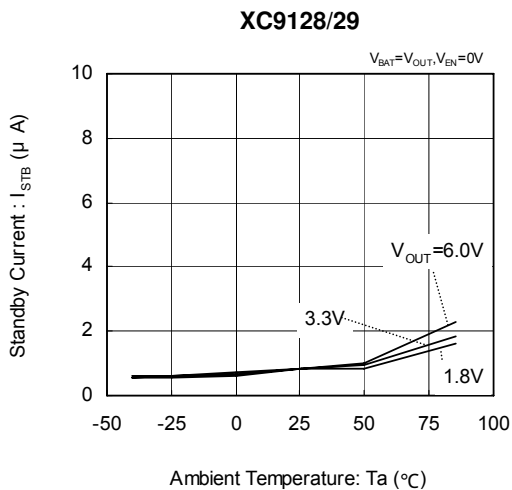

(9) Standby Current vs. Output Voltage

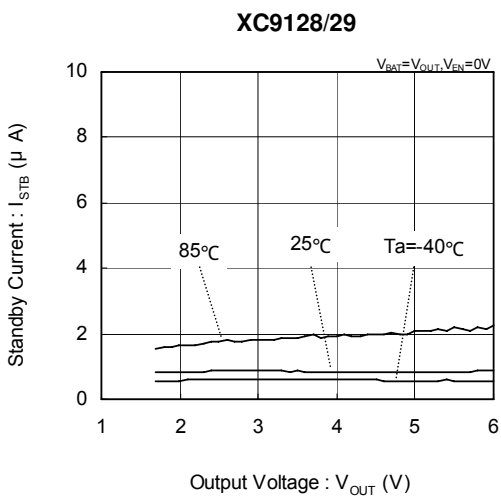

■ **TYPICAL PERFORMANCE CHARACTERISTICS (Continued)**

(10) FB Voltage vs. Ambient Temperature

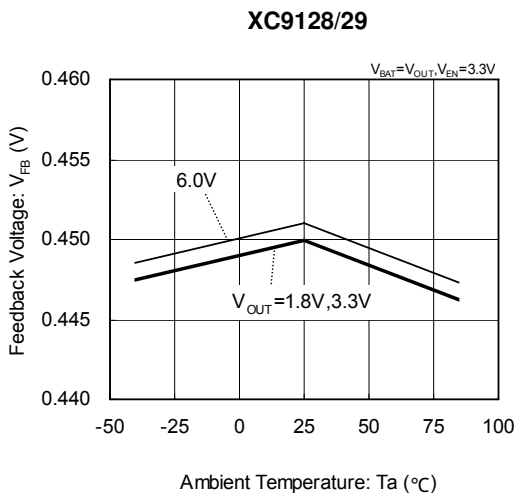

(11) FB Voltage vs. Output Voltage

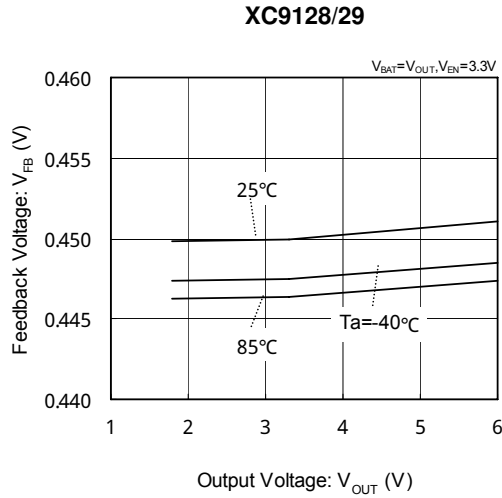

(12) Oscillation Frequency vs. Ambient Temperature

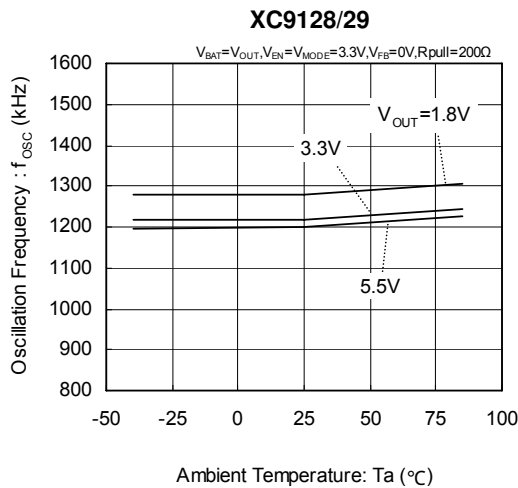

(13) Oscillation Frequency vs. Output Voltage

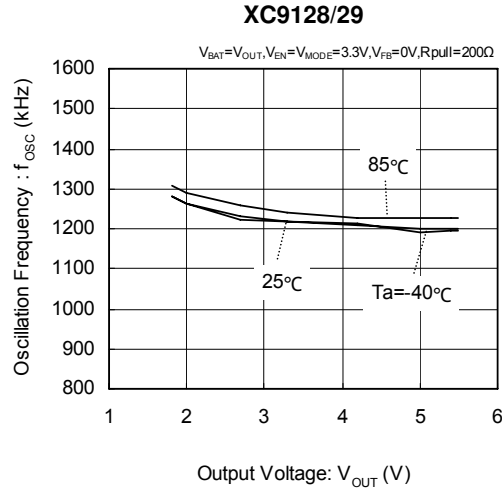

(14) Maximum Duty Cycle vs. Ambient Temperature

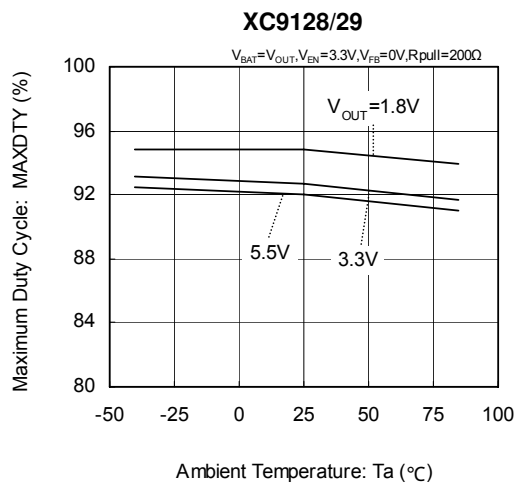

(15) Maximum Duty Cycle vs. Output Voltage

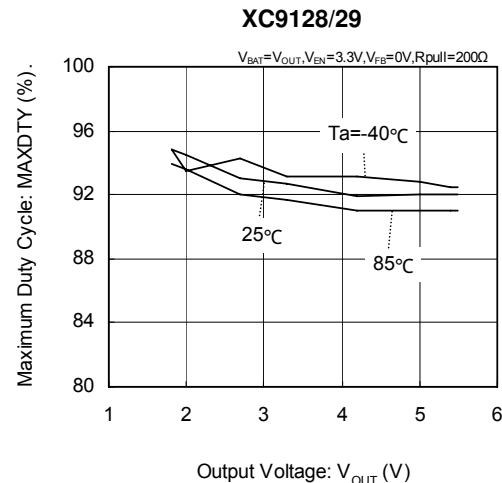

TYPICAL PERFORMANCE CHARACTERISTICS (Continued)

(16) PFM Switch Current vs. Ambient Temperature

XC9128 (V_{OUT}=5.0V)

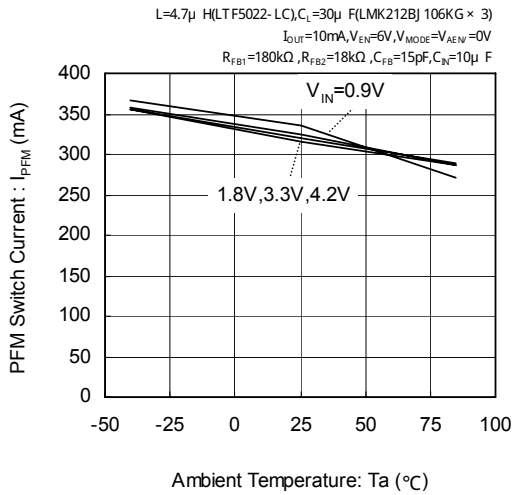

XC9128 (V_{OUT}=3.3V)

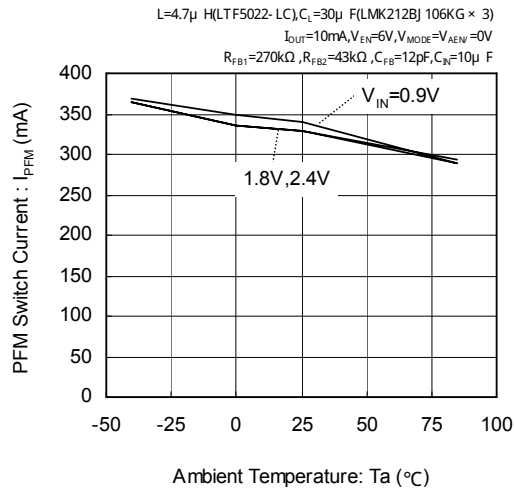

XC9128 (V_{OUT}=1.8V)

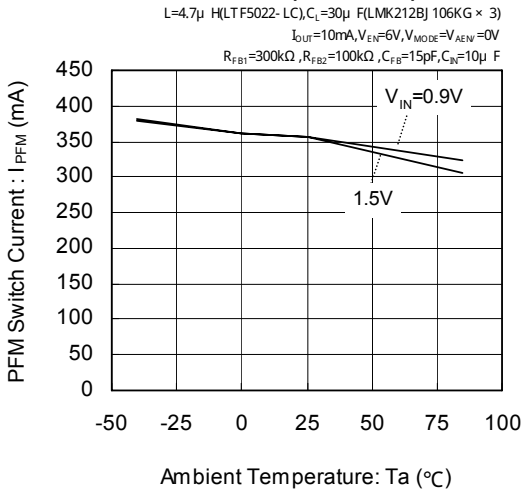

(17) PFM Switch Current vs. Output Voltage

XC9128 (V_{IN}=0.9V)

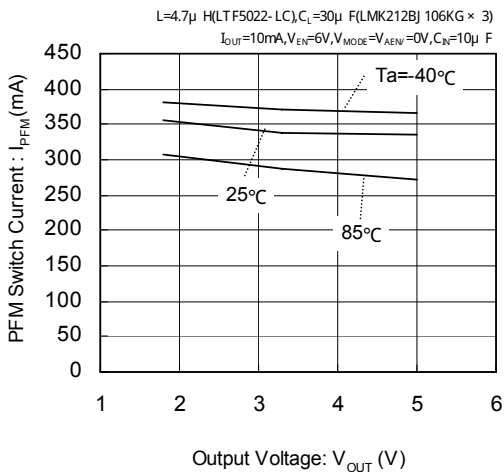

XC9128 (V_{IN}=1.5V)

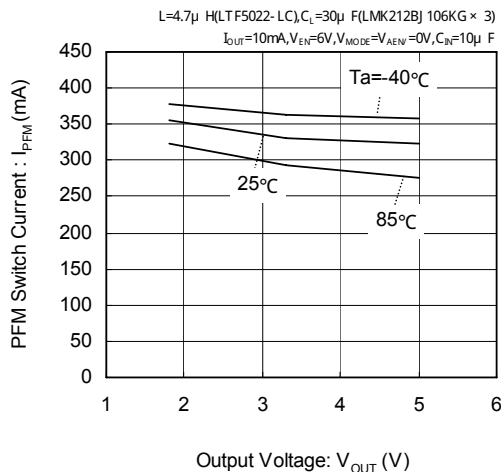

■ **TYPICAL PERFORMANCE CHARACTERISTICS (Continued)**

(18) Limit Current vs. Ambient Temperature

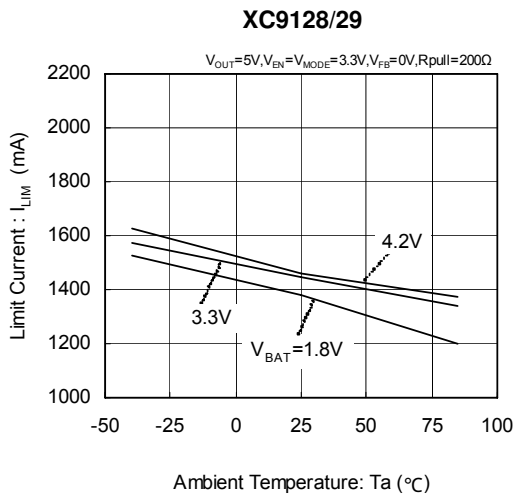

(19) Limit Current vs. Output Voltage

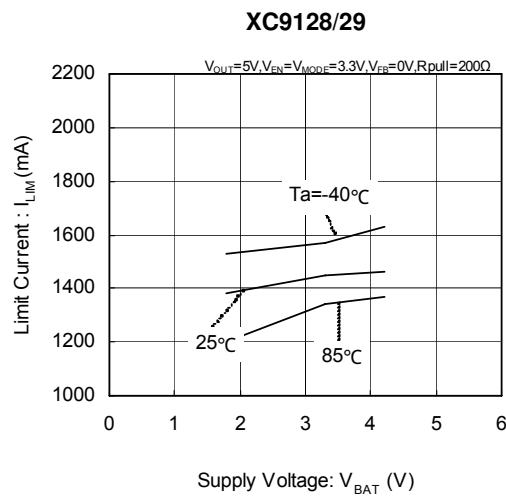

(20) Lx SW"Pch"ON Resistance vs. Ambient Temperature

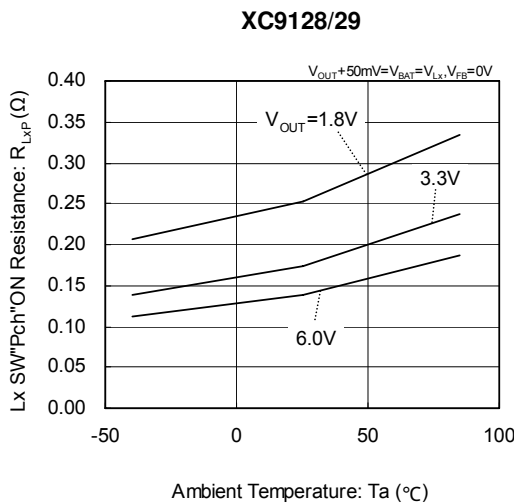

(21) Lx SW"Pch"ON Resistance vs. Output Voltage

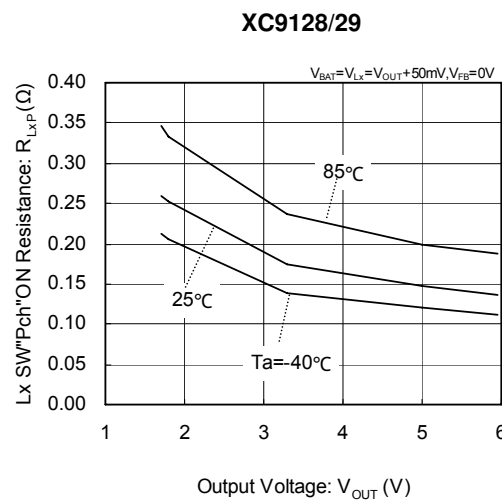

(22) Lx SW"Nch"ON Resistance vs. Ambient Temperature

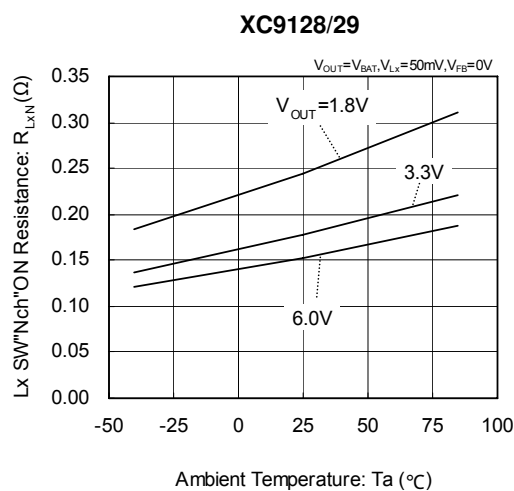

(23) Lx SW"Nch"ON Resistance vs. Output Voltage

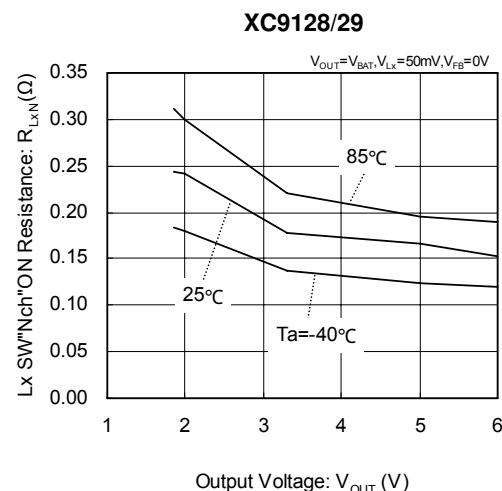

TYPICAL PERFORMANCE CHARACTERISTICS (Continued)

(24) Soft Start Time 1 vs. Ambient Temperature

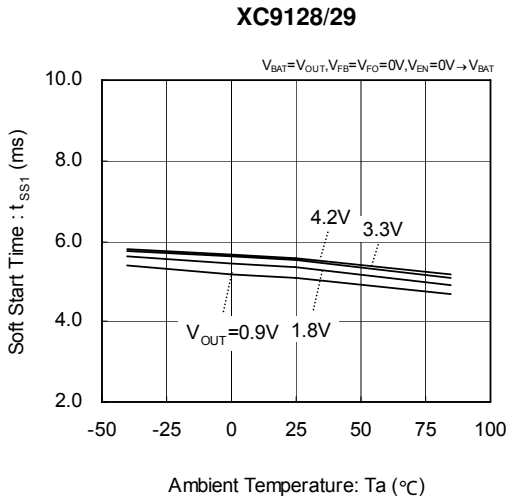

(25) Soft Start Time 1 vs. Output Voltage

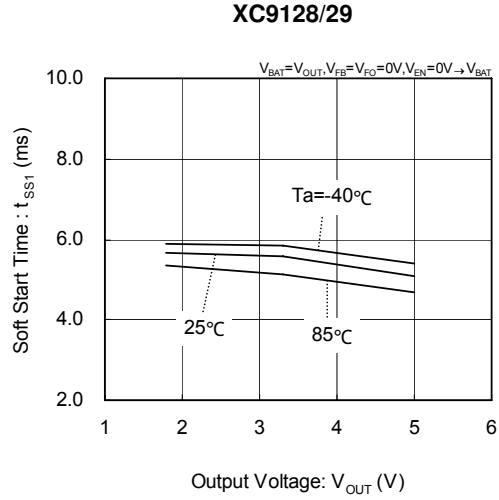

(26) Flag Output Current vs. Ambient Temperature

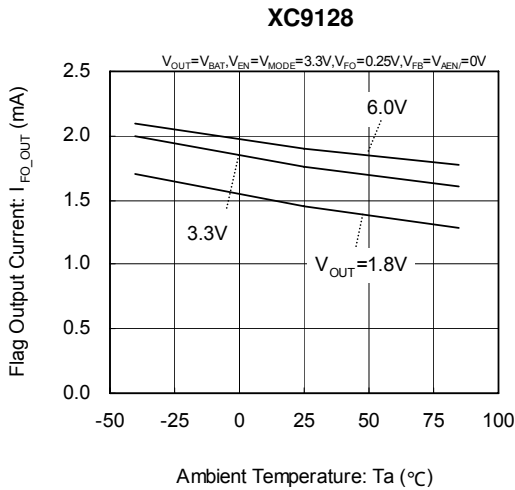

(27) Flag Output Current vs. Output Voltage

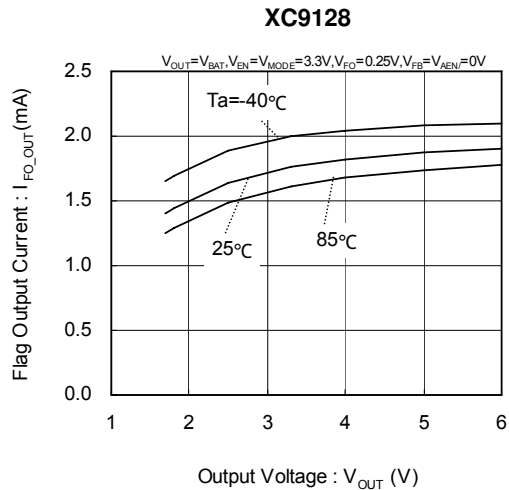

(28) Flag Leakage Current vs. Ambient Temperature

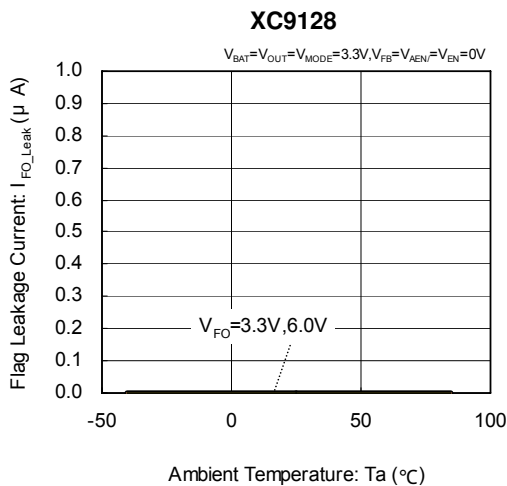

(29) Flag Leakage Current vs. Output Current

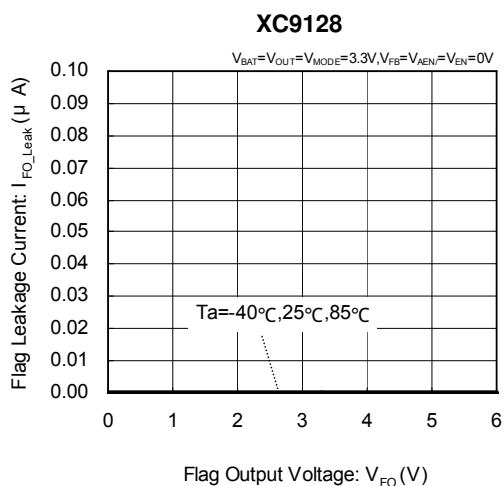

■ **TYPICAL PERFORMANCE CHARACTERISTICS (Continued)**

(30) Low Voltage Protection Voltage vs. Ambient Temperature

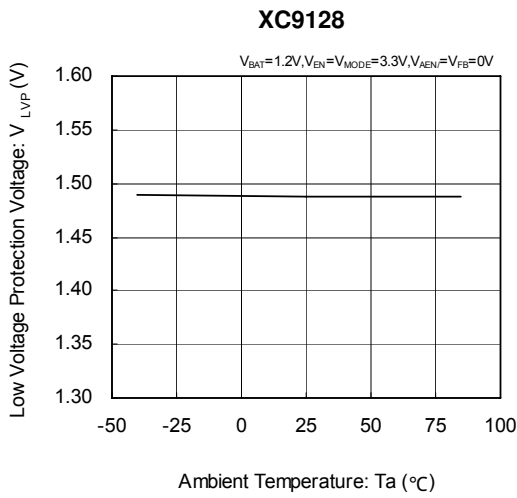

(31) EN "H" Voltage vs. Ambient Temperature

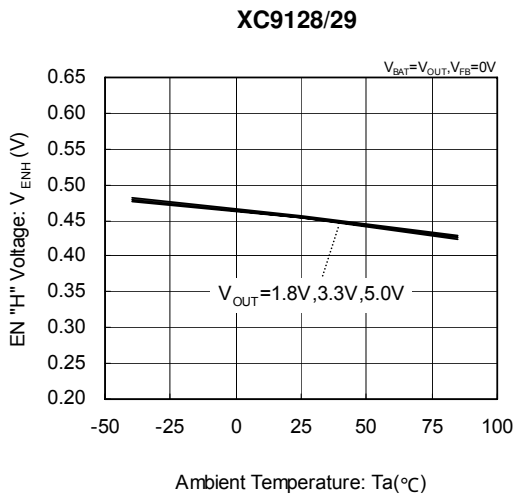

(32) EN "H" Voltage vs. Output Voltage

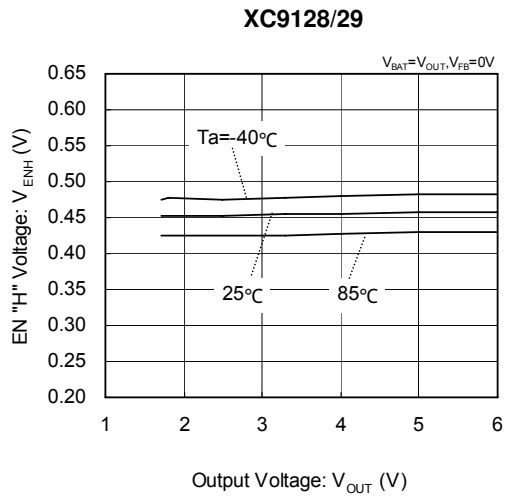

(33) EN "L" Voltage vs. Ambient Temperature

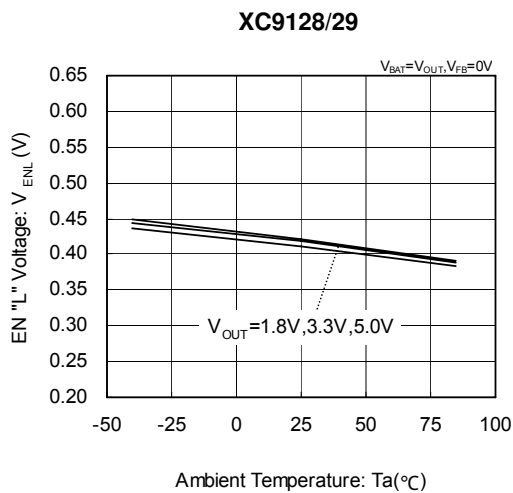

(34) EN "L" Voltage vs. Output Voltage

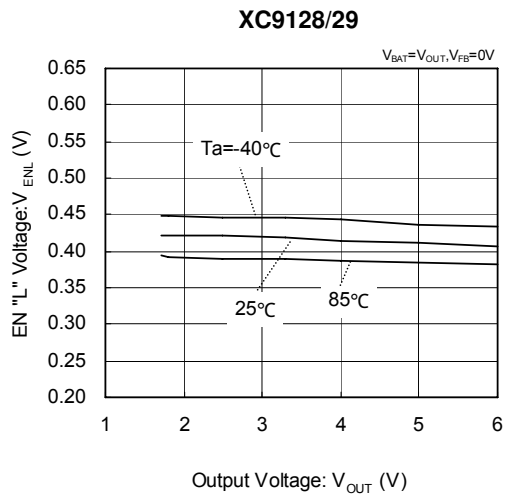

TYPICAL PERFORMANCE CHARACTERISTICS (Continued)

(35) MODE "H" Voltage vs. Ambient Temperature

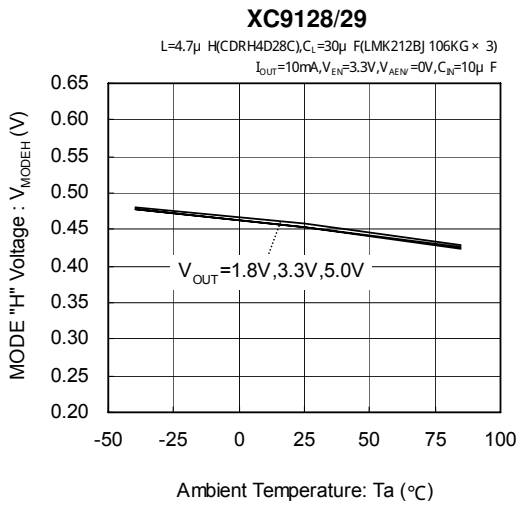

(36) MODE "H" Voltage vs. Output Voltage

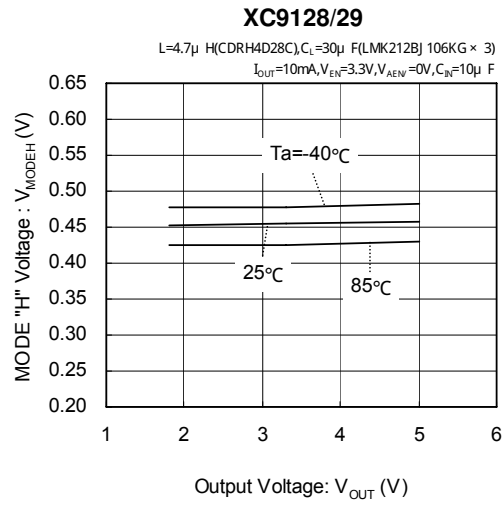

(37) MODE "L" Voltage vs. Ambient Temperature

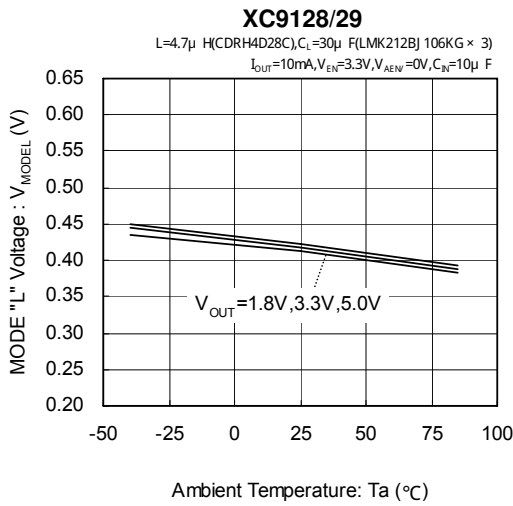

(38) MODE "L" Voltage vs. Output Voltage

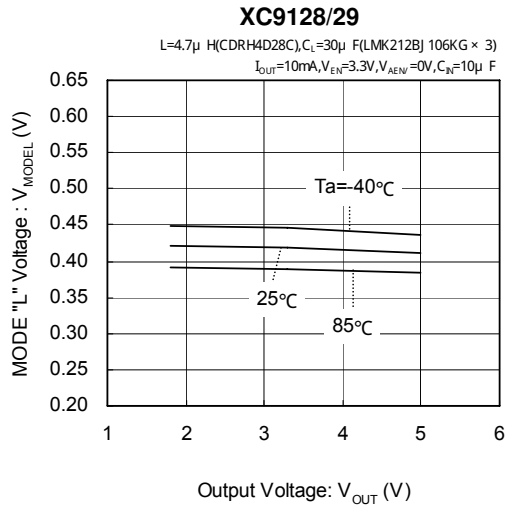

(39) AEN/Voltage vs. Ambient Temperature

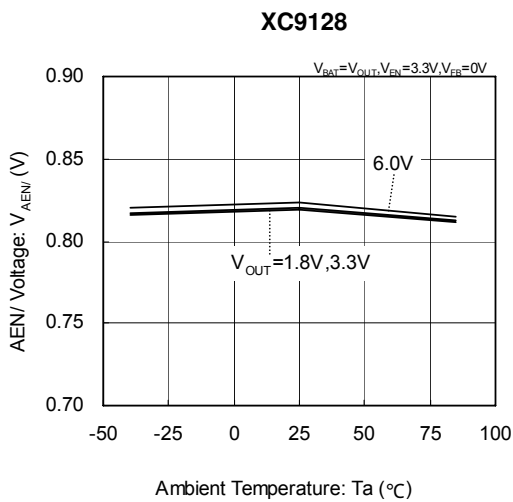

(40) AEN/Voltage vs. Output Voltage

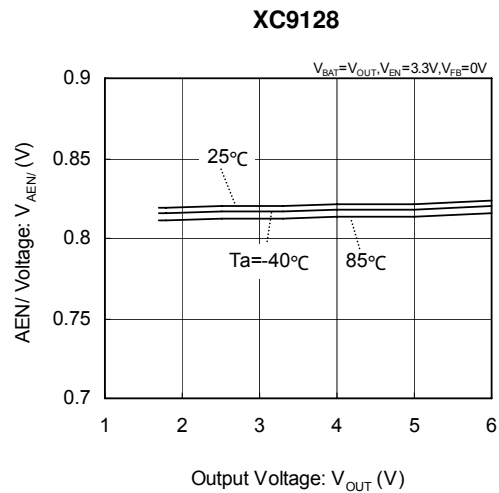

■ TYPICAL PERFORMANCE CHARACTERISTICS (Continued)

(41) Load Transient Response

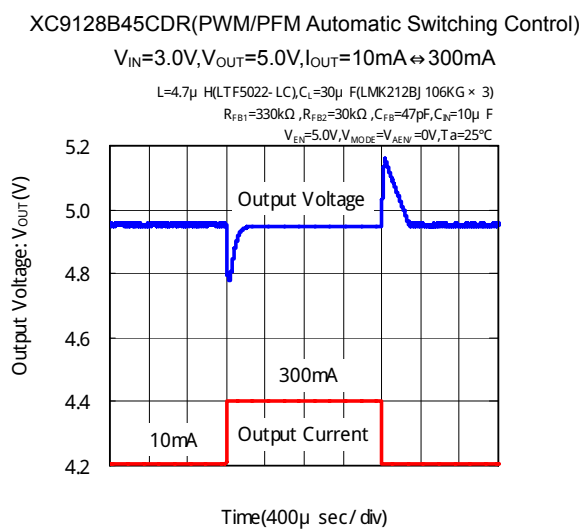
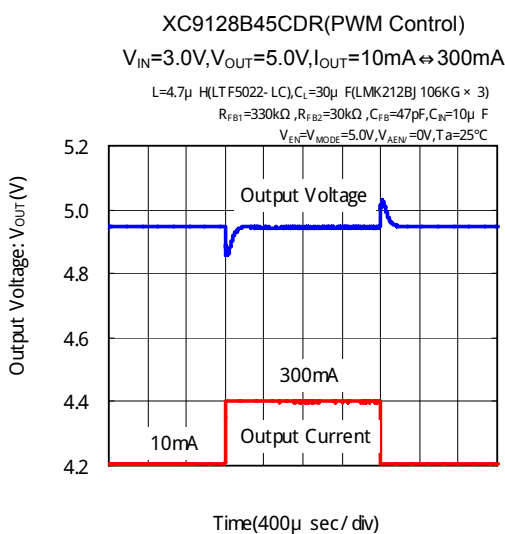
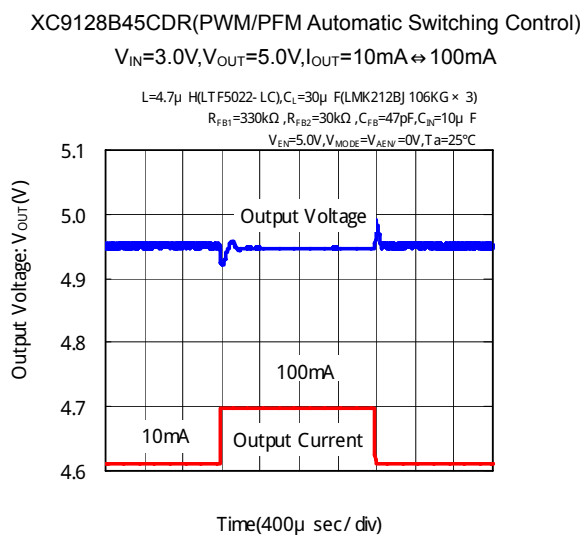
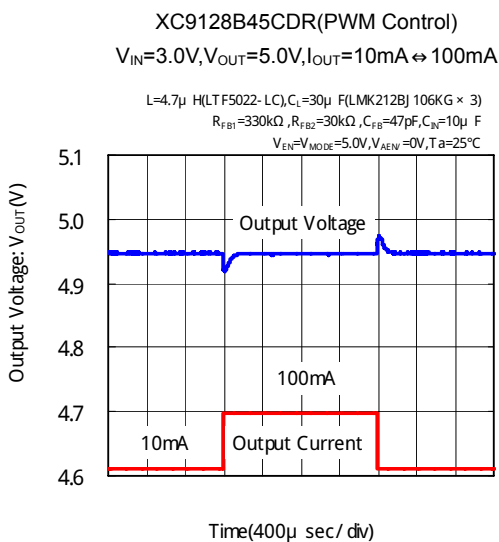
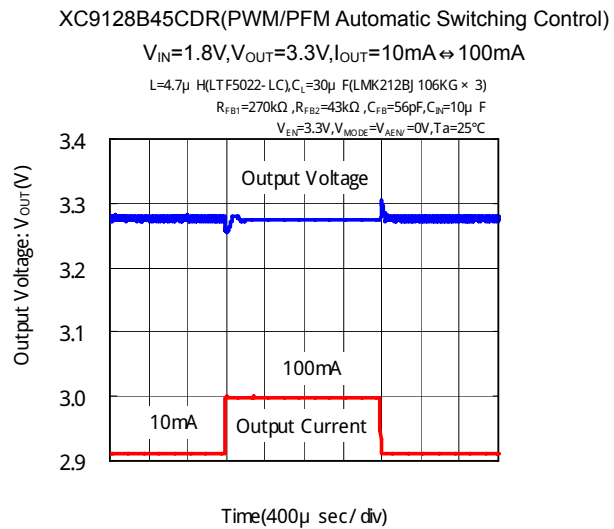
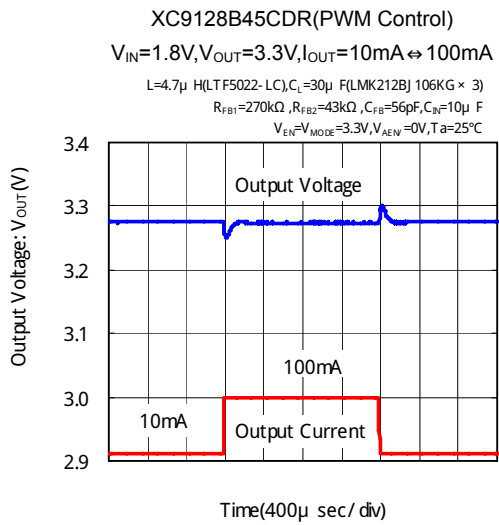

■ PACKAGING INFORMATION

● MSOP-10

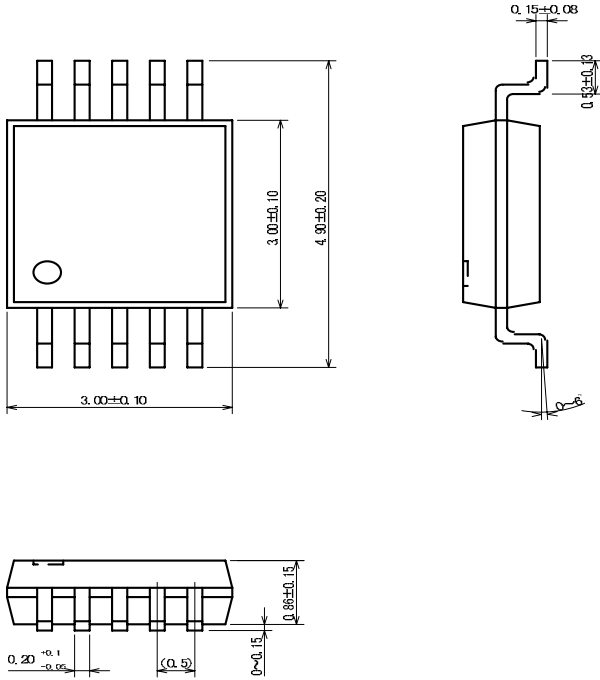

● USP-10B

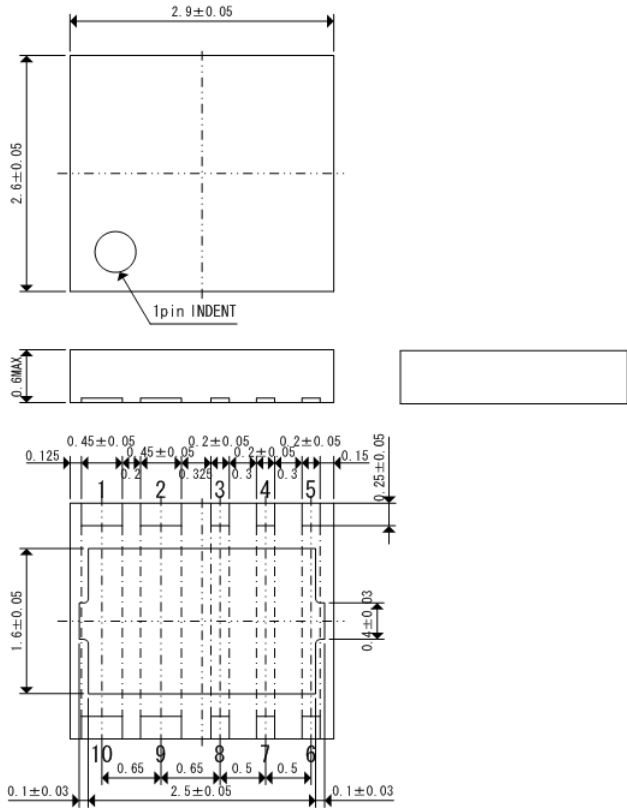

MARKING RULE

• USP-10B

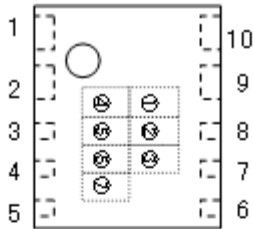

• MSOP-10

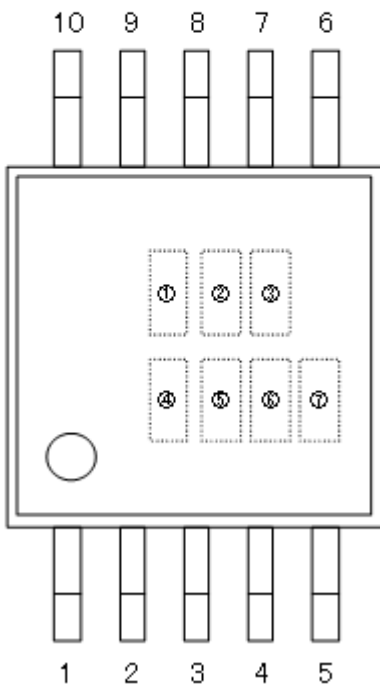

① represents product series.

| MARK | PRODUCT SERIES |
|------|----------------|
| 8 | XC9128 series |
| 9 | XC9129 series |

② represents transistor built-in, output voltage freely set (FB voltage), integral protection type.

| MARK | PRODUCT SERIES |
|------|-----------------------------|
| B | With integral protection |
| D | Without integral protection |

③④ represents reference voltage.

| MARK | | VOLTAGE(V) |
|------|---|------------|
| ③ | ④ | |
| 4 | 5 | 0.45 |

⑤ represents oscillation frequency.

| MARK | OSCILLATION FREQUENCY |
|------|-----------------------|
| C | 1200 |

⑥⑦ represents production lot number

01 to 09, 10 to 99, 0A~ 0Z, 1A ~9Z,A0~Z9,AA~ZZ in order.

(G, I, J, O, Q, W excluded)

*No character inversion used