



Chipsmall Limited consists of a professional team with an average of over 10 year of expertise in the distribution of electronic components. Based in Hongkong, we have already established firm and mutual-benefit business relationships with customers from,Europe,America and south Asia,supplying obsolete and hard-to-find components to meet their specific needs.

With the principle of “Quality Parts,Customers Priority,Honest Operation,and Considerate Service”,our business mainly focus on the distribution of electronic components. Line cards we deal with include Microchip,ALPS,ROHM,Xilinx,Pulse,ON,Everlight and Freescale. Main products comprise IC,Modules,Potentiometer,IC Socket,Relay,Connector.Our parts cover such applications as commercial,industrial, and automotives areas.

We are looking forward to setting up business relationship with you and hope to provide you with the best service and solution. Let us make a better world for our industry!



## Contact us

Tel: +86-755-8981 8866 Fax: +86-755-8427 6832

Email & Skype: info@chipsmall.com Web: www.chipsmall.com

Address: A1208, Overseas Decoration Building, #122 Zhenhua RD., Futian, Shenzhen, China



## Features

- 7.5 ns pin-to-pin logic delays on all pins
- $f_{CNT}$  to 111 MHz
- 144 macrocells with 3,200 usable gates
- Up to 133 user I/O pins
- 5V in-system programmable
  - Endurance of 10,000 program/erase cycles
  - Program/erase over full commercial voltage and temperature range
- Enhanced pin-locking architecture
- Flexible 36V18 Function Block (FB)
  - 90 product terms drive any or all of 18 macrocells within Function Block
  - Global and product term clocks, output enables, set and reset signals
- Extensive IEEE Std 1149.1 boundary-scan (JTAG) support
- Programmable power reduction mode in each macrocell
- Slew rate control on individual outputs
- User programmable ground pin capability
- Extended pattern security features for design protection
- High-drive 24 mA outputs
- 3.3V or 5V I/O capability
- Advanced CMOS 5V FastFLASH technology
- Supports parallel programming of more than one XC9500 concurrently
- Available in 100-pin PQFP, 100-pin TQFP, and 160-pin PQFP packages

## Description

The XC95144 is a high-performance CPLD providing advanced in-system programming and test capabilities for general purpose logic integration. It is comprised of eight 36V18 Function Blocks, providing 3,200 usable gates with propagation delays of 7.5 ns. See [Figure 2](#) for the architecture overview.

## Power Management

Power dissipation can be reduced in the XC95144 by configuring macrocells to standard or low-power modes of operation. Unused macrocells are turned off to minimize power dissipation.

Operating current for each design can be approximated for specific operating conditions using the following equation:

$$I_{CC} \text{ (mA)} = MC_{HP} (1.7) + MC_{LP} (0.9) + MC (0.006 \text{ mA/MHz}) f$$

Where:

$MC_{HP}$  = Macrocells in high-performance mode

$MC_{LP}$  = Macrocells in low-power mode

$MC$  = Total number of macrocells used

$f$  = Clock frequency (MHz)

[Figure 1](#) shows a typical calculation for the XC95144 device.

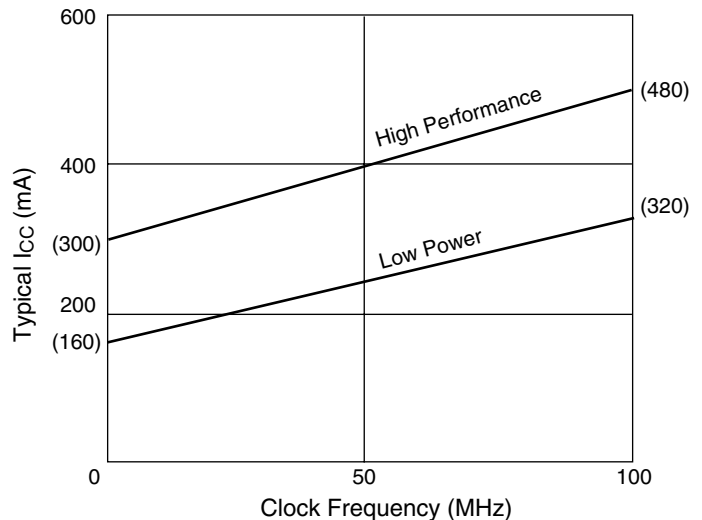

DS067\_01\_110101

Figure 1: Typical  $I_{CC}$  vs. Frequency for XC95144

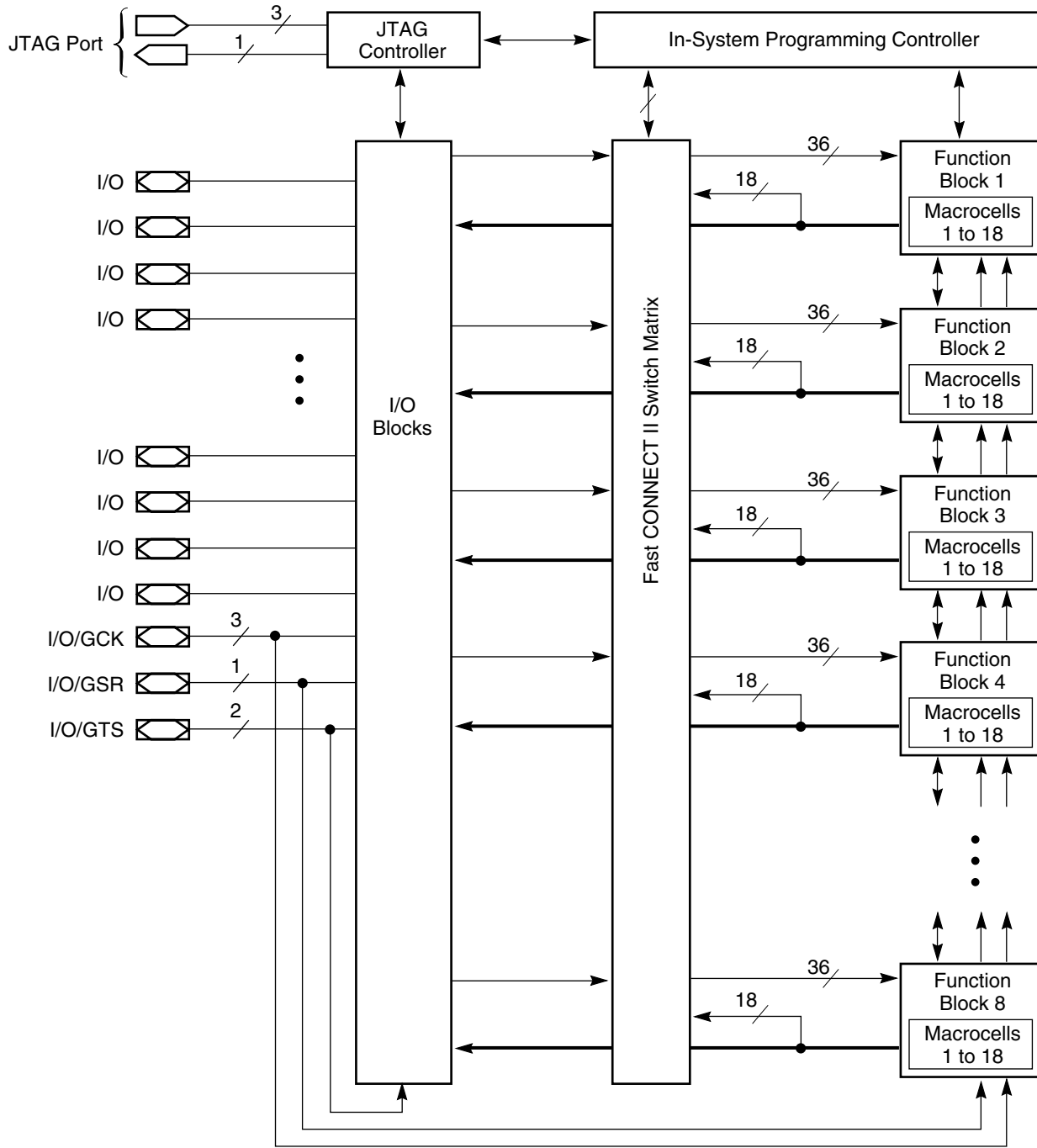

DS067\_02\_110101

Figure 2: XC95144 Architecture

Function block outputs (indicated by the bold line) drive the I/O blocks directly.

## Absolute Maximum Ratings

Symbol	Description	Value	Units
$V_{CC}$	Supply voltage relative to GND	-0.5 to 7.0	V
$V_{IN}$	Input voltage relative to GND	-0.5 to $V_{CC} + 0.5$	V
$V_{TS}$	Voltage applied to 3-state output	-0.5 to $V_{CC} + 0.5$	V
$T_{STG}$	Storage temperature (ambient)	-65 to +150	°C
$T_J$	Junction temperature	+150	°C

### Notes:

- Stresses beyond those listed under Absolute Maximum Ratings may cause permanent damage to the device. These are stress ratings only, and functional operation of the device at these or any other conditions beyond those listed under Operating Conditions is not implied. Exposure to Absolute Maximum Ratings conditions for extended periods of time may affect device reliability.

## Recommended Operation Conditions

Symbol	Parameter		Min	Max	Units
$V_{CCINT}$	Supply voltage for internal logic and input buffers	Commercial $T_A = 0^\circ\text{C}$ to $70^\circ\text{C}$	4.75	5.25	V
		Industrial $T_A = -40^\circ\text{C}$ to $+85^\circ\text{C}$	4.5	5.5	
$V_{CCIO}$	Supply voltage for output drivers for 5V operation	Commercial $T_A = 0^\circ\text{C}$ to $70^\circ\text{C}$	4.75	5.25	V
		Industrial $T_A = -40^\circ\text{C}$ to $+85^\circ\text{C}$	4.5	5.5	
	Supply voltage for output drivers for 3.3V operation	3.0	3.6		
$V_{IL}$	Low-level input voltage		0	0.80	V
$V_{IH}$	High-level input voltage		2.0	$V_{CCINT} + 0.5$	V
$V_O$	Output voltage		0	$V_{CCIO}$	V

## Quality and Reliability Characteristics

Symbol	Parameter	Min	Max	Units
$T_{DR}$	Data Retention	20	-	Years
$N_{PE}$	Program/Erase Cycles (Endurance)	10,000	-	Cycles

## DC Characteristic Over Recommended Operating Conditions

Symbol	Parameter	Test Conditions	Min	Max	Units
$V_{OH}$	Output high voltage for 5V outputs	$I_{OH} = -4.0\text{ mA}$ , $V_{CC} = \text{Min}$	2.4	-	V
	Output high voltage for 3.3V outputs	$I_{OH} = -3.2\text{ mA}$ , $V_{CC} = \text{Min}$	2.4	-	V
$V_{OL}$	Output low voltage for 5V outputs	$I_{OL} = 24\text{ mA}$ , $V_{CC} = \text{Min}$	-	0.5	V
	Output low voltage for 3.3V outputs	$I_{OL} = 10\text{ mA}$ , $V_{CC} = \text{Min}$	-	0.4	V
$I_{IL}$	Input leakage current	$V_{CC} = \text{Max}$ $V_{IN} = \text{GND or } V_{CC}$	-	$\pm 10$	$\mu\text{A}$
$I_{IH}$	I/O high-Z leakage current	$V_{CC} = \text{Max}$ $V_{IN} = \text{GND or } V_{CC}$	-	$\pm 10$	$\mu\text{A}$
$C_{IN}$	I/O capacitance	$V_{IN} = \text{GND}$ $f = 1.0\text{ MHz}$	-	10	pF
$I_{CC}$	Operating supply current (low power mode, active)	$V_I = \text{GND}$ , No load $f = 1.0\text{ MHz}$	160 (Typical)		mA

## AC Characteristics

Symbol	Parameter	XC95144-7		XC95144-10		XC95144-15		Units
		Min	Max	Min	Max	Min	Max	
$T_{PD}$	I/O to output valid	-	7.5	-	10.0	-	15.0	ns
$T_{SU}$	I/O setup time before GCK	4.5	-	6.0	-	8.0	-	ns
$T_H$	I/O hold time after GCK	0	-	0	-	0	-	ns
$T_{CO}$	GCK to output valid	-	4.5	-	6.0	-	8.0	ns
$f_{CNT}^{(1)}$	16-bit counter frequency	125.0	-	111.1	-	95.2	-	MHz
$f_{SYSTEM}^{(2)}$	Multiple FB internal operating frequency	83.3	-	66.7	-	55.6	-	MHz
$T_{PSU}$	I/O setup time before p-term clock input	0.5	-	2.0	-	4.0	-	ns
$T_{PH}$	I/O hold time after p-term clock input	4.0	-	4.0	-	4.0	-	ns
$T_{PCO}$	P-term clock output valid	-	8.5	-	10.0	-	12.0	ns
$T_{OE}$	GTS to output valid	-	5.5	-	6.0	-	11.0	ns
$T_{OD}$	GTS to output disable	-	5.5	-	6.0	-	11.0	ns
$T_{POE}$	Product term OE to output enabled	-	9.5	-	10.0	-	14.0	ns
$T_{POD}$	Product term OE to output disabled	-	9.5	-	10.0	-	14.0	ns
$T_{WLH}$	GCK pulse width (High or Low)	4.0	-	4.5	-	5.5	-	ns
$T_{APRPW}$	Asynchronous preset/reset pulse width (High or Low)	7.0	-	7.5	-	8.0	-	ns

**Notes:**

- $f_{CNT}$  is the fastest 16-bit counter frequency available, using the local feedback when applicable.  $f_{CNT}$  is also the Export Control Maximum flip-flop toggle rate,  $f_{TOG}$ .
- $f_{SYSTEM}$  is the internal operating frequency for general purpose system designs spanning multiple FBs.

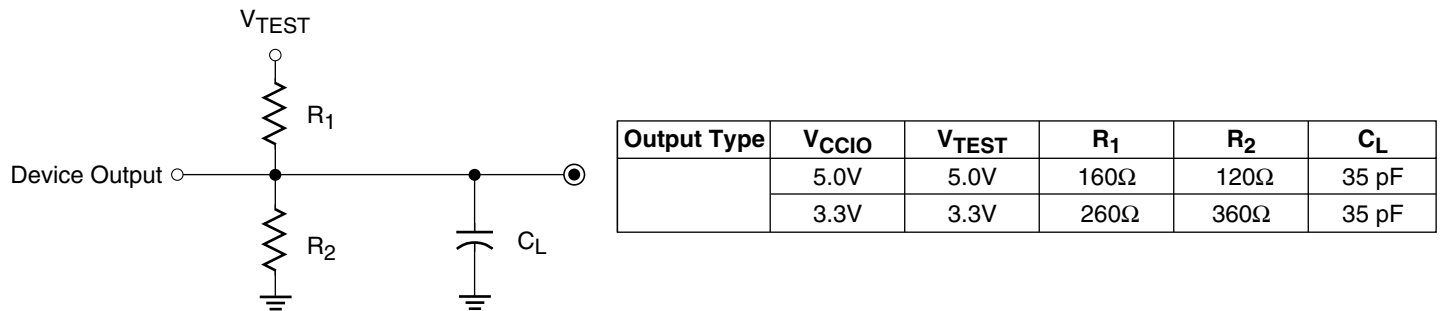

DS067\_03\_110101

Figure 3: AC Load Circuit

## Internal Timing Parameters

Symbol	Parameter	XC95144-7		XC95144-10		XC95144-15		Units
		Min	Max	Min	Max	Min	Max	
<b>Buffer Delays</b>								
$T_{IN}$	Input buffer delay	-	2.5	-	3.5	-	4.5	ns
$T_{GCK}$	GCK buffer delay	-	1.5	-	2.5	-	3.0	ns
$T_{GSR}$	GSR buffer delay	-	4.5	-	6.0	-	7.5	ns
$T_{GTS}$	GTS buffer delay	-	5.5	-	6.0	-	11.0	ns
$T_{OUT}$	Output buffer delay	-	2.5	-	3.0	-	4.5	ns
$T_{EN}$	Output buffer enable/disable delay	-	0	-	0	-	0	ns
<b>Product Term Control Delays</b>								
$T_{PTCK}$	Product term clock delay	-	3.0	-	3.0	-	2.5	ns
$T_{PTSR}$	Product term set/reset delay	-	2.0	-	2.5	-	3.0	ns
$T_{PTTS}$	Product term 3-state delay	-	4.5	-	3.5	-	5.0	ns
<b>Internal Register and Combinatorial Delays</b>								
$T_{PDI}$	Combinatorial logic propagation delay	-	0.5	-	1.0	-	3.0	ns
$T_{SUI}$	Register setup time	1.5	-	2.5	-	3.5	-	ns
$T_{HI}$	Register hold time	3.0	-	3.5	-	4.5	-	ns
$T_{COI}$	Register clock to output valid time	-	0.5	-	0.5	-	0.5	ns
$T_{AOI}$	Register async. S/R to output delay	-	6.5	-	7.0	-	8.0	ns
$T_{RAI}$	Register async. S/R recover before clock	7.5	-	10.0	-	10.0	-	ns
$T_{LOGI}$	Internal logic delay	-	2.0	-	2.5	-	3.0	ns
$T_{LOGILP}$	Internal low power logic delay	-	10.0	-	11.0	-	11.5	ns
<b>Feedback Delays</b>								
$T_F$	FastCONNECT feedback delay	-	8.0	-	9.5	-	11.0	ns
$T_{LF}$	Function block local feedback delay	-	4.0	-	3.5	-	3.5	ns
<b>Time Adders</b>								
$T_{PTA}^{(1)}$	Incremental product term allocator delay	-	1.0	-	1.0	-	1.0	ns
$T_{SLEW}$	Slew-rate limited delay	-	4.0	-	4.5	-	5.0	ns

**Notes:**

- $T_{PTA}$  is multiplied by the span of the function as defined in the XC9500 family data sheet.

## XC95144 I/O Pins

Function Block	Macro-cell	TQ100	PQ100	PQ160	BScan Order
1	1	–	–	25	429
1	2	11	13	18	426
1	3	12	14	19	423
1	4	–	–	27	420
1	5	13	15	21	417
1	6	14	16	22	414
1	7	–	–	32	411
1	8	15	17	23	408
1	9	16	18	24	405
1	10	–	–	34	402
1	11	17	19	26	399
1	12	18	20	28	396
1	13	–	–	38	393
1	14	19	21	29	390
1	15	20	22	30	387
1	16	–	–	39	384
1	17	22 <sup>[1]</sup>	24 <sup>[1]</sup>	33 <sup>[1]</sup>	381 <sup>[1]</sup>
1	18	–	–	–	378
2	1	–	–	158	375
2	2	99 <sup>[1]</sup>	1 <sup>[1]</sup>	159 <sup>[1]</sup>	372 <sup>[1]</sup>
2	3	–	–	3	369
2	4	–	–	5	366
2	5	1 <sup>[1]</sup>	3 <sup>[1]</sup>	2 <sup>[1]</sup>	363 <sup>[1]</sup>
2	6	2 <sup>[1]</sup>	4 <sup>[1]</sup>	4 <sup>[1]</sup>	360 <sup>[1]</sup>
2	7	–	–	7	357
2	8	3 <sup>[1]</sup>	5 <sup>[1]</sup>	6 <sup>[1]</sup>	354 <sup>[1]</sup>
2	9	4 <sup>[1]</sup>	6 <sup>[1]</sup>	8 <sup>[1]</sup>	351 <sup>[1]</sup>
2	10	–	–	9	348
2	11	6	8	11	345
2	12	7	9	12	342
2	13	–	–	14	339
2	14	8	10	13	336
2	15	9	11	15	333
2	16	–	–	16	330
2	17	10	12	17	327
2	18	–	–	–	324

Function Block	Macro-cell	TQ100	PQ100	PQ160	BScan Order
3	1	–	–	43	321
3	2	23 <sup>[1]</sup>	25 <sup>[1]</sup>	35 <sup>[1]</sup>	318 <sup>[1]</sup>
3	3	–	–	45	315
3	4	–	–	48	312
3	5	24	26	36	309
3	6	25	27	37	306
3	7	–	–	50	303
3	8	27 <sup>[1]</sup>	29 <sup>[1]</sup>	42 <sup>[1]</sup>	300 <sup>[1]</sup>
3	9	28	30	44	297
3	10	–	–	52	294
3	11	29	31	47	291
3	12	30	32	49	288
3	13	–	–	53	285
3	14	32	34	54	282
3	15	33	35	56	279
3	16	–	–	55	276
3	17	34	36	57	273
3	18	–	–	–	270
4	1	–	–	132	267
4	2	87	89	140	264
4	3	–	–	147	261
4	4	–	–	149	258
4	5	89	91	142	255
4	6	90	92	143	252
4	7	–	–	150	249
4	8	91	93	144	246
4	9	92	94	145	243
4	10	–	–	151	240
4	11	93	95	146	237
4	12	94	96	148	234
4	13	–	–	153	231
4	14	95	97	152	228
4	15	96	98	154	225
4	16	–	–	155	222
4	17	97	99	156	219
4	18	–	–	–	216

### Notes:

- Global control pin.  
Macrocell outputs to package pins subject to change, contact factory for latest information. Power, GND, JTAG, and Global Signals are fixed.

**XC95144 I/O Pins (Continued)**

Function Block	Macro-cell	TQ100	PQ100	PQ160	BScan Order
5	1	–	–	65	213
5	2	35	37	58	210
5	3	–	–	66	207
5	4	–	–	67	204
5	5	36	38	59	201
5	6	37	39	60	198
5	7	–	–	74	195
5	8	39	41	62	192
5	9	40	42	63	189
5	10	–	–	76	186
5	11	41	43	64	183
5	12	42	44	68	180
5	13	–	–	78	177
5	14	43	45	69	174
5	15	46	48	72	171
5	16	–	–	83	168
5	17	49	51	77	165
5	18	–	–	–	162
6	1	–	–	–	159
6	2	74	76	117	156
6	3	–	–	119	153
6	4	–	–	123	150
6	5	76	78	122	147
6	6	77	79	124	144
6	7	–	–	125	141
6	8	78	80	126	138
6	9	79	81	129	135
6	10	–	–	128	132
6	11	80	82	133	129
6	12	81	83	134	126
6	13	–	–	130	123
6	14	82	84	135	120
6	15	85	87	138	117
6	16	–	–	131	114
6	17	86	88	139	111
6	18	–	–	–	108

Function Block	Macro-cell	TQ100	PQ100	PQ160	BScan Order
7	1	–	–	–	105
7	2	50	52	79	102
7	3	–	–	84	99
7	4	–	–	85	96
7	5	52	54	82	93
7	6	53	55	86	90
7	7	–	–	87	87
7	8	54	56	88	84
7	9	55	57	90	81
7	10	–	–	89	78
7	11	56	58	92	75
7	12	58	60	95	72
7	13	–	–	91	69
7	14	59	61	96	66
7	15	60	62	97	63
7	16	–	–	93	60
7	17	61	63	98	57
7	18	–	–	–	54
8	1	–	–	–	51
8	2	63	65	101	48
8	3	–	–	105	45
8	4	–	–	107	42
8	5	64	66	102	39
8	6	65	67	103	36
8	7	–	–	109	33
8	8	66	68	104	30
8	9	67	69	106	27
8	10	–	–	112	24
8	11	68	70	108	21
8	12	70	72	111	18
8	13	–	–	114	15
8	14	71	73	113	12
8	15	72	74	115	9
8	16	–	–	118	6
8	17	73	75	116	3
8	18	–	–	–	0

**Notes:**

- Global control pin.  
Macrocell outputs to package pins subject to change, contact factory for latest information. Power, GND, JTAG, and Global Signals are fixed.



## XC95144 Global, JTAG, and Power Pins

Pin Type	TQ100	PQ100	PQ160
I/O/GCK1	22	24	33
I/O/GCK2	23	25	35
I/O/GCK3	27	29	42
I/O/GTS1	3	5	6
I/O/GTS2	4	6	8
I/O/GTS3	1	3	2
I/O/GTS4	2	4	4
I/O/GSR	99	1	159
TCK	48	50	75
TDI	45	47	71
TDO	83	85	136
TMS	47	49	73
V <sub>CCINT</sub> 5V	5, 57, 98	7, 59, 100	10, 46, 94, 157
V <sub>CCIO</sub> 3.3V/5V	26, 38, 51, 88	28, 40, 53, 90	1, 41, 61, 81, 121, 141
GND	100, 21, 31, 44, 62, 69, 75, 84	2, 23, 33, 46, 64, 71, 77, 86	20, 31, 40, 51, 70, 80, 99, 100, 110, 120, 127, 137, 160
No Connects	–	–	–

## Device Part Marking and Ordering Combination Information

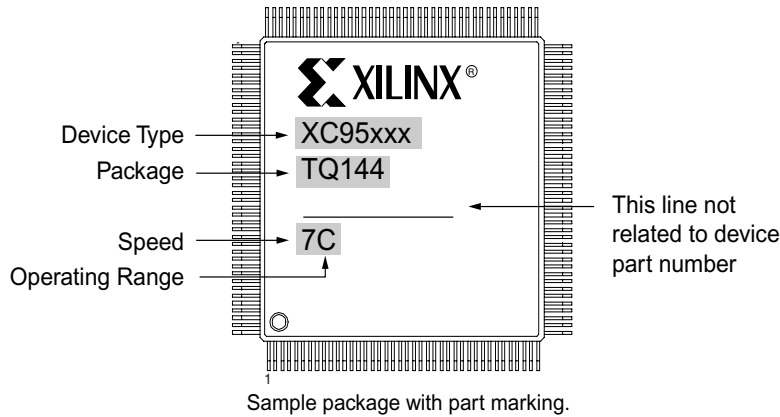

Device Ordering and Part Marking Number	Speed (pin-to-pin delay)	Pkg. Symbol	No. of Pins	Package Type	Operating Range <sup>(1)</sup>
XC95144-7PQ100C	7.5 ns	PQ100	100-pin	Plastic Quad Flat Pack (PQFP)	C
XC95144-7PQG100C	7.5 ns	PQG100	100-pin	Plastic Quad Flat Pack (PQFP); Pb-Free	C
XC95144-7TQ100C	7.5 ns	TQ100	100-pin	Thin Quad Flat Pack (TQFP)	C
XC95144-7TQG100C	7.5 ns	TQG100	100-pin	Thin Quad Flat Pack (TQFP); Pb-Free	C
XC95144-7PQ160C	7.5 ns	PQ160	160-pin	Plastic Quad Flat Pack (PQFP)	C
XC95144-7PQG160C	7.5 ns	PQG160	160-pin	Plastic Quad Flat Pack (PQFP); Pb-Free	C
XC95144-10PQ100C	10 ns	PQ100	100-pin	Plastic Quad Flat Pack (PQFP)	C
XC95144-10PQG100C	10 ns	PQG100	100-pin	Plastic Quad Flat Pack (PQFP); Pb-Free	C
XC95144-10TQ100C	10 ns	TQ100	100-pin	Thin Quad Flat Pack (TQFP)	C
XC95144-10TQG100C	10 ns	TQG100	100-pin	Thin Quad Flat Pack (TQFP); Pb-Free	C
XC95144-10PQ160C	10 ns	PQ160	160-pin	Plastic Quad Flat Pack (PQFP)	C
XC95144-10PQG160C	10 ns	PQG160	160-pin	Plastic Quad Flat Pack (PQFP); Pb-Free	C
XC95144-10PQ100I	10 ns	PQ100	100-pin	Plastic Quad Flat Pack (PQFP)	I
XC95144-10PQG100I	10 ns	PQG100	100-pin	Plastic Quad Flat Pack (PQFP); Pb-Free	I
XC95144-10TQ100I	10 ns	TQ100	100-pin	Thin Quad Flat Pack (TQFP)	I
XC95144-10TQG100I	10 ns	TQG100	100-pin	Thin Quad Flat Pack (TQFP); Pb-Free	I
XC95144-10PQ160I	10 ns	PQ160	160-pin	Plastic Quad Flat Pack (PQFP)	I
XC95144-10PQG160I	10 ns	PQG160	160-pin	Plastic Quad Flat Pack (PQFP); Pb-Free	I
XC95144-15PQ100C	15 ns	PQ100	100-pin	Plastic Quad Flat Pack (PQFP)	C
XC95144-15PQG100C	15 ns	PQG100	100-pin	Plastic Quad Flat Pack (PQFP); Pb-Free	C
XC95144-15TQ100C	15 ns	TQ100	100-pin	Thin Quad Flat Pack (TQFP)	C
XC95144-15TQG100C	15 ns	TQG100	100-pin	Thin Quad Flat Pack (TQFP); Pb-Free	C
XC95144-15PQ160C	15 ns	PQ160	160-pin	Plastic Quad Flat Pack (PQFP)	C
XC95144-15PQG160C	15 ns	PQG160	160-pin	Plastic Quad Flat Pack (PQFP); Pb-Free	C
XC95144-15PQ100I	15 ns	PQ100	100-pin	Plastic Quad Flat Pack (PQFP)	I
XC95144-15PQG100I	15 ns	PQG100	100-pin	Plastic Quad Flat Pack (PQFP); Pb-Free	I
XC95144-15TQ100I	15 ns	TQ100	100-pin	Thin Quad Flat Pack (TQFP)	I
XC95144-15TQG100I	15 ns	TQG100	100-pin	Thin Quad Flat Pack (TQFP); Pb-Free	I

Device Ordering and Part Marking Number	Speed (pin-to-pin delay)	Pkg. Symbol	No. of Pins	Package Type	Operating Range <sup>(1)</sup>
XC95144-15PQ160I	15 ns	PQ160	160-pin	Plastic Quad Flat Pack (PQFP)	I
XC95144-15PQG160I	15 ns	PQG160	160-pin	Plastic Quad Flat Pack (PQFP); Pb-Free	I

**Notes:**

1. C = Commercial:  $T_A = 0^\circ$  to  $+70^\circ\text{C}$ ; I = Industrial:  $T_A = -40^\circ$  to  $+85^\circ\text{C}$

## Additional Information

[XC9500 data sheets and application notes.](#)

[Packages](#)

## Revision History

The following table shows the revision history for this document.

Date	Version	Revision
12/04/98	4.0	Update AC characteristics and internal parameters.
06/18/03	5.0	Updated format.
08/21/03	5.1	Updated Package Device Marking Pin 1 orientation.
11/06/03	5.2	Update pin count on PQ160 packages.
02/16/04	5.3	Correct GTS pin information by removing rows on GTS3 GTS4 from table on page 8. Add links to additional information.
04/15/05	5.4	Added asynchronous preset/reset pulse width specification ( $T_{APRPW}$ ).
01/03/06	5.5	Added GTS3 and GTS4 pins to table on page 8.
04/03/06	5.6	Added Warranty Disclaimer. Added Pb-Free package ordering information.
05/28/09	5.7	Removed table note reference from Function Block 2, Macrocell 3 in <b>XC95144 I/O Pins</b> .

## Notice of Disclaimer

THE XILINX HARDWARE FPGA AND CPLD DEVICES REFERRED TO HEREIN (“PRODUCTS”) ARE SUBJECT TO THE TERMS AND CONDITIONS OF THE XILINX LIMITED WARRANTY WHICH CAN BE VIEWED AT <http://www.xilinx.com/warranty.htm>. THIS LIMITED WARRANTY DOES NOT EXTEND TO ANY USE OF PRODUCTS IN AN APPLICATION OR ENVIRONMENT THAT IS NOT WITHIN THE SPECIFICATIONS STATED IN THE XILINX DATA SHEET. ALL SPECIFICATIONS ARE SUBJECT TO CHANGE WITHOUT NOTICE. PRODUCTS ARE NOT DESIGNED OR INTENDED TO BE FAIL-SAFE OR FOR USE IN ANY APPLICATION REQUIRING FAIL-SAFE PERFORMANCE, SUCH AS LIFE-SUPPORT OR SAFETY DEVICES OR SYSTEMS, OR ANY OTHER APPLICATION THAT INVOKES THE POTENTIAL RISKS OF DEATH, PERSONAL INJURY, OR PROPERTY OR ENVIRONMENTAL DAMAGE (“CRITICAL APPLICATIONS”). USE OF PRODUCTS IN CRITICAL APPLICATIONS IS AT THE SOLE RISK OF CUSTOMER, SUBJECT TO APPLICABLE LAWS AND REGULATIONS.