



Chipsmall Limited consists of a professional team with an average of over 10 year of expertise in the distribution of electronic components. Based in Hongkong, we have already established firm and mutual-benefit business relationships with customers from,Europe,America and south Asia,supplying obsolete and hard-to-find components to meet their specific needs.

With the principle of “Quality Parts,Customers Priority,Honest Operation,and Considerate Service”,our business mainly focus on the distribution of electronic components. Line cards we deal with include Microchip,ALPS,ROHM,Xilinx,Pulse,ON,Everlight and Freescale. Main products comprise IC,Modules,Potentiometer,IC Socket,Relay,Connector.Our parts cover such applications as commercial,industrial, and automotives areas.

We are looking forward to setting up business relationship with you and hope to provide you with the best service and solution. Let us make a better world for our industry!



Contact us

Tel: +86-755-8981 8866 Fax: +86-755-8427 6832

Email & Skype: info@chipsmall.com Web: www.chipsmall.com

Address: A1208, Overseas Decoration Building, #122 Zhenhua RD., Futian, Shenzhen, China



GET CONNECTED WITH SOFTWARE DESIGNED SILICON

The XC-2 Ethernet Kit provides a rapid and cost effective route for developing ethernet connected designs in XMOS silicon. Based around the four-core XS1-G4 programmable device from XMOS, the XC-2 Kit provides the hardware needed to connect to a 10/100 Ethernet system using an RJ45 socket.

The credit card sized XC-2 board is easily interfaced to your development system using 0.1" pitch expansion, or you can add your own components using the on-board 0.1" pitch through-hole prototyping area.

RAPID DEVELOPMENT OF YOUR SYSTEM

The XC-2 Ethernet Kit comes with reference designs and examples including a software MII/MAC function and embedded web-server that are available as source code.

You can download and debug your applications on the XC-2 Card using the XTAG connector. Alternatively you can program your application into the on-board SPI flash from the XS1-G4 device or the external header, providing standalone operation.

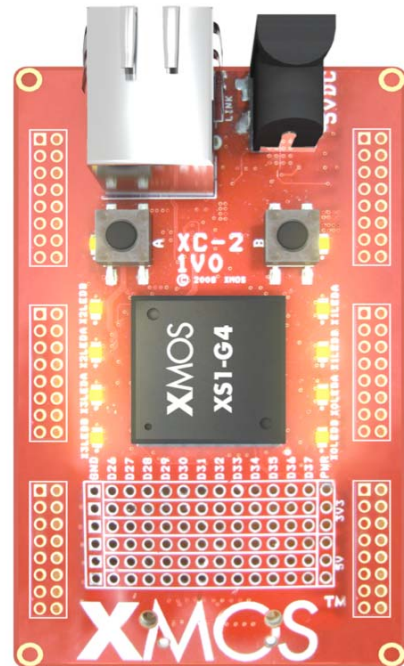

XC-2 ETHERNET KIT AT A GLANCE

- XC-2 Card features:
 - XS1-G4 four-XCore™ 400MHz device: 1600 MIPS, 256KB RAM, 32KB OTP
 - RJ45 ethernet socket
 - Two pushbuttons
 - 10 user LEDs
 - 84 pins user I/O expansion total from four XCores™
 - External link and XSYS debug interface
 - Credit card size (85 x 54 mm)
- XTAG Connector
- USB Cable
- 5V external PSU
- Comprehensive software development tool suite
 - XC, C and C++ compilers, linker and mapper
 - Simulator and visual debugger
 - Supports Windows XP SP2, Red Hat Linux 4.6 and OS X 10.4
- Example software available as source code
 - 10/100 Ethernet MAC/MII driver code
 - TCP/IP and UDP stack
 - Embedded web server
 - Interactive driver demo over ethernet

XC-2 ETHERNET CARD BLOCK DIAGRAM

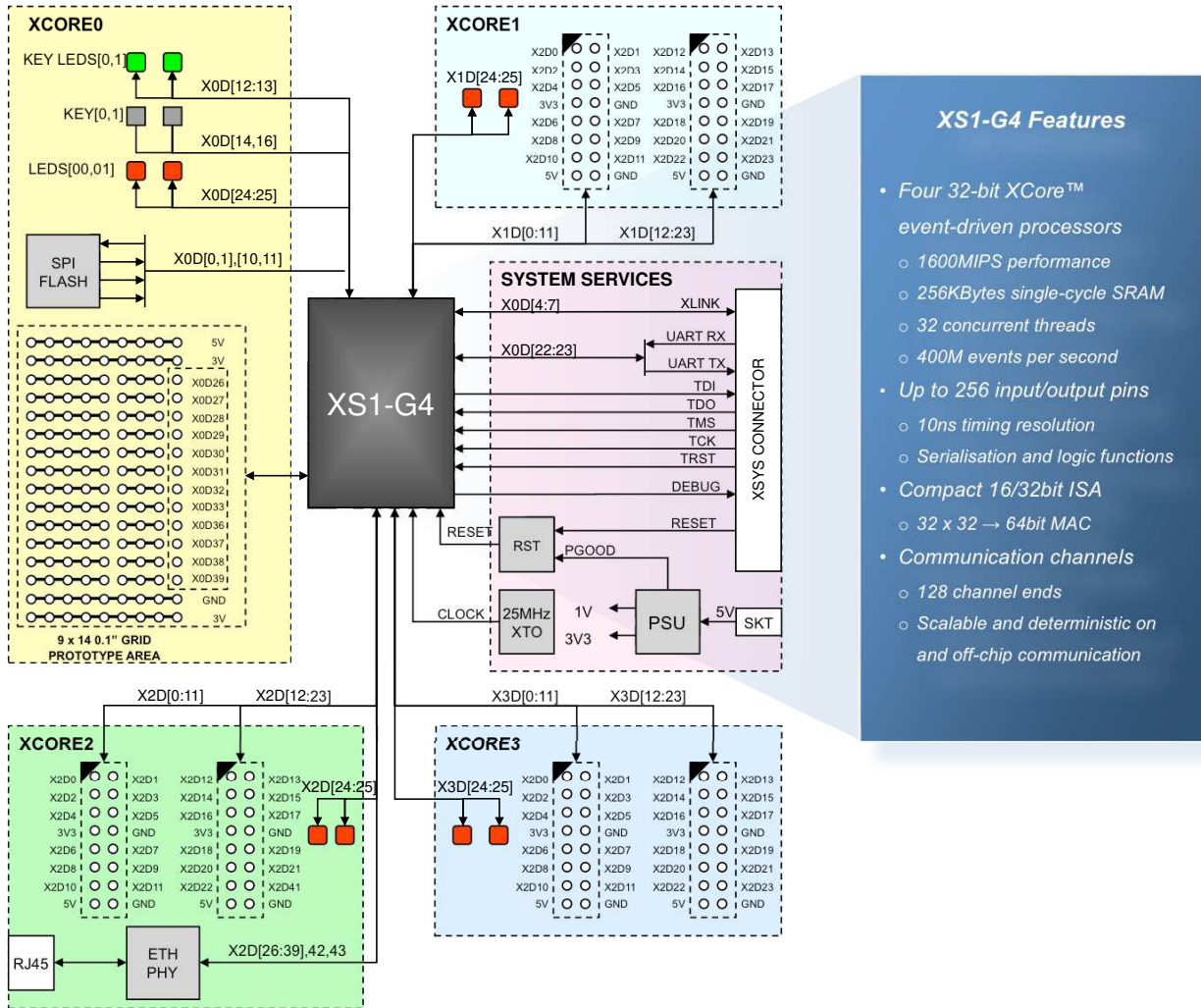

SOFTWARE DEVELOPMENT

XMOS provides development tools to take your design from concept to volume production.

The tools are based on a standard embedded software flow that supports XC, C and C++. XC includes extensions to C for concurrency, communications, and timed input-output operations. As well as providing compilers and a debugger, the tools include utilities for deploying compiled binaries onto your development board.

The tools are intuitive and easy to use, and can be driven from the XMOS Development Environment (XDE) or the command line.

The tools can be downloaded free of charge for Windows, Mac and Linux platforms from www.xmos.com.

