



Chipsmall Limited consists of a professional team with an average of over 10 year of expertise in the distribution of electronic components. Based in Hongkong, we have already established firm and mutual-benefit business relationships with customers from,Europe,America and south Asia,supplying obsolete and hard-to-find components to meet their specific needs.

With the principle of “Quality Parts,Customers Priority,Honest Operation,and Considerate Service”,our business mainly focus on the distribution of electronic components. Line cards we deal with include Microchip,ALPS,ROHM,Xilinx,Pulse,ON,Everlight and Freescale. Main products comprise IC,Modules,Potentiometer,IC Socket,Relay,Connector.Our parts cover such applications as commercial,industrial, and automotives areas.

We are looking forward to setting up business relationship with you and hope to provide you with the best service and solution. Let us make a better world for our industry!



Contact us

Tel: +86-755-8981 8866 Fax: +86-755-8427 6832

Email & Skype: info@chipsmall.com Web: www.chipsmall.com

Address: A1208, Overseas Decoration Building, #122 Zhenhua RD., Futian, Shenzhen, China





Product Technical Specification

AirPrime XM1110



SIERRA
WIRELESS®

41111059
Rev 1

Important Notice

Due to the nature of wireless communications, transmission and reception of data can never be guaranteed. Data may be delayed, corrupted (i.e., have errors) or be totally lost. Although significant delays or losses of data are rare when wireless devices such as the Sierra Wireless modem are used in a normal manner with a well-constructed network, the Sierra Wireless modem should not be used in situations where failure to transmit or receive data could result in damage of any kind to the user or any other party, including but not limited to personal injury, death, or loss of property. Sierra Wireless accepts no responsibility for damages of any kind resulting from delays or errors in data transmitted or received using the Sierra Wireless modem, or for failure of the Sierra Wireless modem to transmit or receive such data.

Safety and Hazards

Do not operate the Sierra Wireless modem in areas where blasting is in progress, where explosive atmospheres may be present, near medical equipment, near life support equipment, or any equipment which may be susceptible to any form of radio interference. In such areas, the Sierra Wireless modem **MUST BE POWERED OFF**. The Sierra Wireless modem can transmit signals that could interfere with this equipment.

Do not operate the Sierra Wireless modem in any aircraft, whether the aircraft is on the ground or in flight. In aircraft, the Sierra Wireless modem **MUST BE POWERED OFF**. When operating, the Sierra Wireless modem can transmit signals that could interfere with various onboard systems.

Note: Some airlines may permit the use of cellular phones while the aircraft is on the ground and the door is open. Sierra Wireless modems may be used at this time.

The driver or operator of any vehicle should not operate the Sierra Wireless modem while in control of a vehicle. Doing so will detract from the driver or operator's control and operation of that vehicle. In some states and provinces, operating such communications devices while in control of a vehicle is an offence.

Limitation of Liability

The information in this manual is subject to change without notice and does not represent a commitment on the part of Sierra Wireless. SIERRA WIRELESS AND ITS AFFILIATES SPECIFICALLY DISCLAIM LIABILITY FOR ANY AND ALL DIRECT, INDIRECT, SPECIAL, GENERAL, INCIDENTAL, CONSEQUENTIAL, PUNITIVE OR EXEMPLARY DAMAGES INCLUDING, BUT NOT LIMITED TO, LOSS OF PROFITS OR REVENUE OR ANTICIPATED PROFITS OR REVENUE ARISING OUT OF THE USE OR INABILITY TO USE ANY SIERRA WIRELESS PRODUCT, EVEN IF SIERRA WIRELESS AND/OR ITS AFFILIATES HAS BEEN ADVISED OF THE POSSIBILITY OF SUCH DAMAGES OR THEY ARE FORESEEABLE OR FOR CLAIMS BY ANY THIRD PARTY.

Notwithstanding the foregoing, in no event shall Sierra Wireless and/or its affiliates aggregate liability arising under or in connection with the Sierra Wireless product, regardless of the number of events, occurrences, or claims giving rise to liability, be in excess of the price paid by the purchaser for the Sierra Wireless product.

Patents

This product may contain technology developed by or for Sierra Wireless Inc. This product includes technology licensed from QUALCOMM®. This product is manufactured or sold by Sierra Wireless Inc. or its affiliates under one or more patents licensed from InterDigital Group and MMP Portfolio Licensing.

Copyright

© 2017 Sierra Wireless. All rights reserved.

Trademarks

Sierra Wireless®, AirPrime®, AirLink®, AirVantage® and the Sierra Wireless logo are registered trademarks of Sierra Wireless.

Windows® and Windows Vista® are registered trademarks of Microsoft Corporation.

Macintosh® and Mac OS X® are registered trademarks of Apple Inc., registered in the U.S. and other countries.

QUALCOMM® is a registered trademark of QUALCOMM Incorporated. Used under license.

Other trademarks are the property of their respective owners.

Contact Information

Sales information and technical support, including warranty and returns	Web: sierrawireless.com/company/contact-us/ Global toll-free number: 1-877-687-7795 6:00 am to 6:00 pm PST
Corporate and product information	Web: sierrawireless.com

Revision History

Revision number	Release date	Changes
1	June 23, 2017	Initial revision in SWI template.

>> Contents

Function Description	6
Overview	6
Potential Applications	6
Product Highlights and Features	7
System Block Diagram	8
Multi-tone Active Interference Canceller	8
1PPS	8
AGPS for faster TTFF (EPO in flash™)	8
EASY™	9
AlwaysLocate™	9
LOCUS	10
PPS sync NMEA	10
Specifications	11
Mechanical Dimensions	11
Recommended PCB Pad Layout	11
Pin Configuration	12
Pin Assignment	12
Description of I/O Pins	13
Specifications	15
Absolute Maximum Ranges	16
Operating Conditions	16
Protocols	17
NMEA Output Sentences	17
GGA—Time, Position and Related Data of Navigation Fix	17
GSA—GNSS DOP and Active Satellites, Including GPS(GPGSA) and GLONASS(GLGSA)	19
GSV— Satellites in View, Including GPS(GPGSV) and GLONASS(GLGSV)	20
RMC—Recommended Minimum Navigation Information	22
VTG—Course and Speed Information Relating to the Ground	23

MTK NMEA Command Protocols	24
Reference Design	25
Reference Schematic Design for Using the RTCM/I2C/SPI	25
Schematic Reference Design for the RTCM	25
Schematic Reference Design for Using I2C	26
Schematic Reference Design for the SPI Bus	27
Patch (Passive) Antenna	28
Active Antenna	29
Packing and Handling	30
Packaging and Handling (Tape Reel)	30
Storage and Floor Life Guidelines	31
Moisture Color Coded Card & Caution Label	31
Conditions for Pre-baking	32
Drying	33
ESD Handling	34
Reflow Soldering Temperature Profile	35
SMT Reflow Soldering Temperature Profile (For Reference Only)	35
Manual Soldering	38

>> 1: Function Description

Overview

The XM1110 is a GNSS (GPS + GLONASS) receiver; it is one of the smallest MediaTek-based modules in the world, for it has an ultra-compact size of 9.0 x 9.5 x 2.1 mm in a QFN Package. This ultra-compact module provides multiple interfaces such as I2C, SPI & UART, and its unique design of SMPS is capable of reducing power consumption to a great extent.

The XM1110 is built based on MediaTek's new generation GNSS Chipset MT3333. It supports up to 210 PRN channels with 99 search channels and 33 simultaneous tracking channels. With support of QZSS, SBAS (WAAS, EGNOS, MSAS), QZSS and AGPS, XM1110 can provide even more accurate positioning. Its *Tone Active Interference Canceller* is capable of removing 12 active noise sources, enabling more flexibility in system design.

The XM1110 is integrated along with power managements and many advanced features, including AlwaysLocate™, EASY™, EPO™, PPS sync NMEA and logger. It is ideally suitable for power sensitive devices especially in portable applications.

Potential Applications

- Handheld Devices
- M2M applications
- Asset management
- Surveillance systems
- Wearable products



Figure 1-1: XM1110

Product Highlights and Features

- 33 tracking/ 99 acquisition-channel GPS +GLONASS receiver
- Supports QZSS & SBAS(WAAS, EGNOS, MSAS, GAGAN)¹
- Sensitivity: -165dBm
- Update Rate: up to 10Hz²
- 12 multi-tone active interference canceller²
- High accuracy 1-PPS timing (± 20 ns RMS) and the pulse width is 100ms
- AGPS Support for Fast TTFF (EPO in flashTM; choose from 7, 14, or 30 days)
- EASYTM: Self-Generated Orbit Prediction for instant positioning fix³
- AlwaysLocateTM Intelligent Algorithm (Advance Power Periodic Mode) for power saving³
- PPS sync NMEA³
- LOCUS (Embedded Logger Function)
- Consumption current(@3.3V):
 - For GPS+GLONASS
 - Acquisition: 23mA/ 26mA /30mA (min / typical / max)
 - Full Power Tracking: 21mA / 23mA /28mA (min / typical / max)
 - GLP (GNSS low-power) Tracking: 7mA / 16mA / 32mA (min / typical / max)
- RoHS

-
1. GAGAN will be supported upon its starting date of service.
 2. SBAS can only be enabled when update rate is equal or less than to 5Hz.
 3. The features need customized firmware or command programming handled by customer. Please refer to our "PMTK Command List".

System Block Diagram

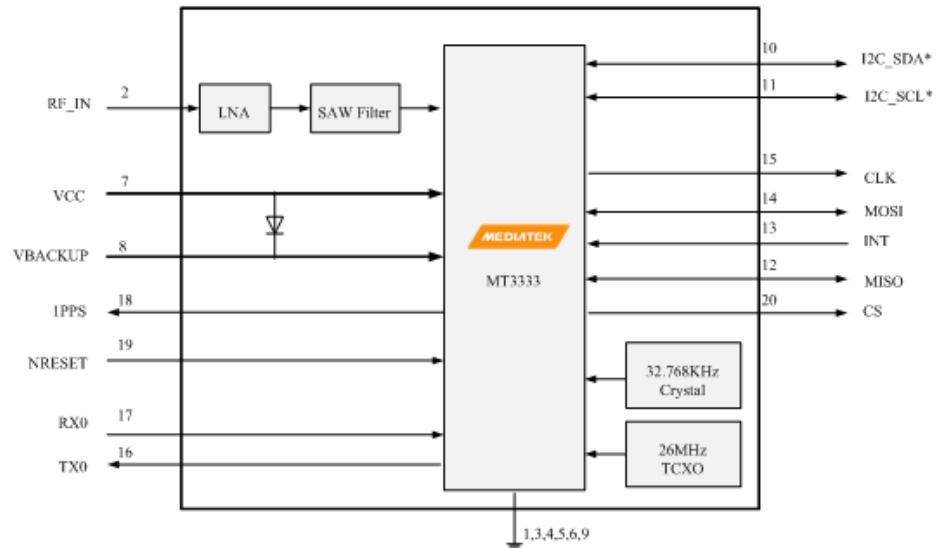

Figure 1-2: System Block Diagram. *I2C disabled in XM1110 by default, keep pin floating.

Multi-tone Active Interference Canceller

Navigation systems often integrate with variant applications that are not limited to Wi-Fi, GSM/GPRS, 3G/4G, Bluetooth. Such systems often generate RF harmonics which would influence the GPS reception and performance.

The embedded Multi-tone Active Interference Canceller (MTAIC) can reject unwanted RF harmonics of the nearby on-board active components. MTAIC improves the capacity of GPS reception, eliminating the need for hardware integration engineering to make hardware changes. The XM1110 cancels up to 12 independent channels continuous interference wave.

1PPS

The XM1110 generates a-pulse-per-second signal (1 PPS). It is an electrical signal which precisely indicates the start of a second with the accuracy of $\pm 20\text{ns}$ RMS (Root Mean Square). The PPS signal is provided through a designated output pin for many external applications. The pulse is not only limited to being active every second but is also allowed to set up the required duration, frequency, and active high/low through a programmable user-defined setting.

AGPS for faster TTFF (EPO in flash™)

The AGPS (EPO in flash™) provides predicated EPO (Extended Prediction Orbit) data to speed up TTFF (Time To First Fix). This feature is useful when a satellite signal is weak. AGPS can be downloaded from an FTP server via the Internet or

through a wireless network. The GPS engine in the module will apply EPO data to assist with position calculation when navigation information from satellites is insufficient. For more details on EPO, please contact us.

EASY™

EASY™ (Embedded Assist System) is for quick positioning/TTFB when information received from the satellites is insufficient (weak signal). When EASY™ is enabled, the GPS engine will automatically calculate and then predict single ephemeris up to three days. The predicted information will be saved into the memory and the GPS engine will then use the saved information for later positioning. Backup power (VBACKUP) is required for EASY™.

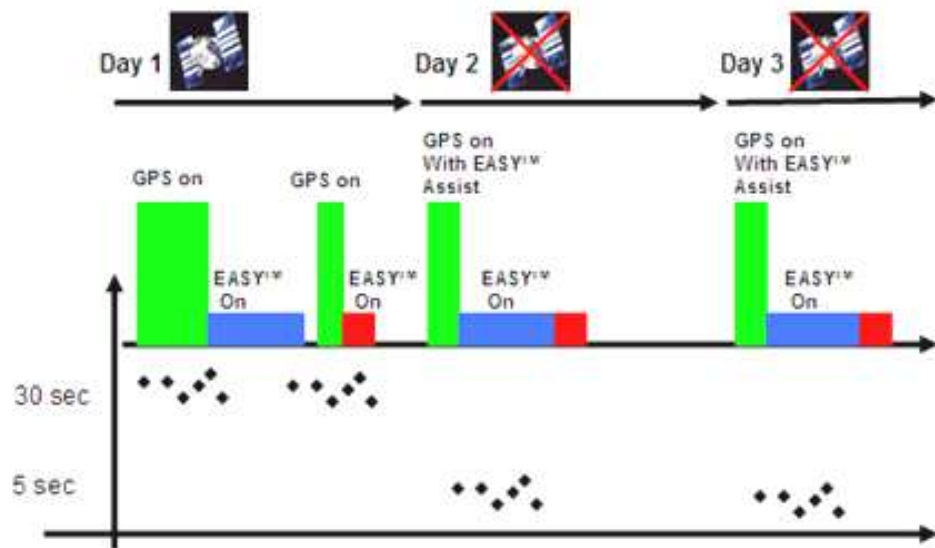

Figure 1-3: Operation of EASY™

When the module obtains information from GPS satellites, the GPS engine will start to pre-calculate and predict orbits automatically for three days.

AlwaysLocate™

In *AlwaysLocate™* mode, the on/off time can be adjusted adaptively to achieve balance between positioning accuracy and power consumption depending on environmental or motion conditions.

Figure 1-4 gives some insight on power saving in different cases when *AlwaysLocate™* mode is enabled. For command detail, please contact Sierra Wireless sales staff.

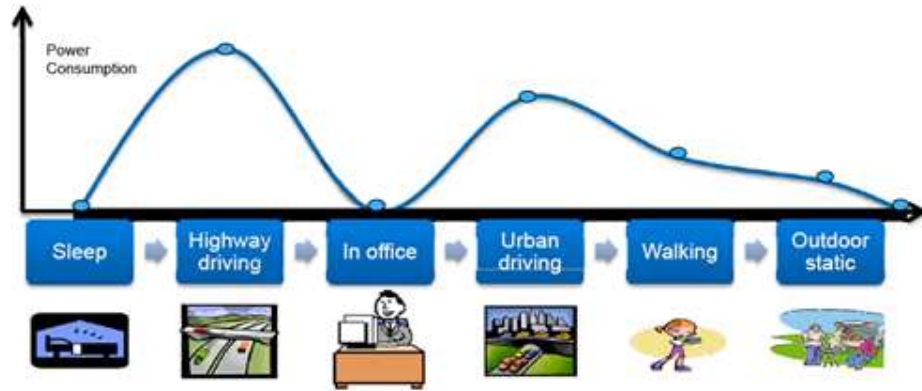

Figure 1-4: AlwaysLocatie

LOCUS

When LOCUS (Embedded Logger Function) is enabled, the receiver module will become a logger-capable device. It does not need any host or external flash data format such as UTC, latitude, longitude, valid or checksum for GPS data logging. The maximum log duration is up to two days under AlwaysLocate™.

PPS sync NMEA

Pulse-Per-Second (PPS) VS. NMEA can be used in the time service. The latency range of the beginning of UART Tx is between 465ms~485 ms at the MT3333 platform and behind the rising edge of PPS.

The PPS sync NMEA only supports 1Hz NMEA output and baud rate at 115200~14400 bps. For baud rates at 9600 bps and 4800 bps, only the RMC NMEA sentence is supported. If NMEA sentence outputs are supported even at the low baud rate, per-second transmission may exceed the threshold of one second.

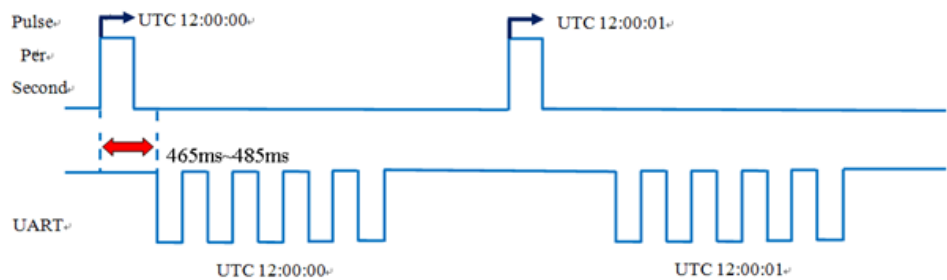

Figure 1-5: PPS sync NMEA

2: Specifications

Mechanical Dimensions

Dimension: (Unit: mm, Tolerance: +/- 0.2mm)

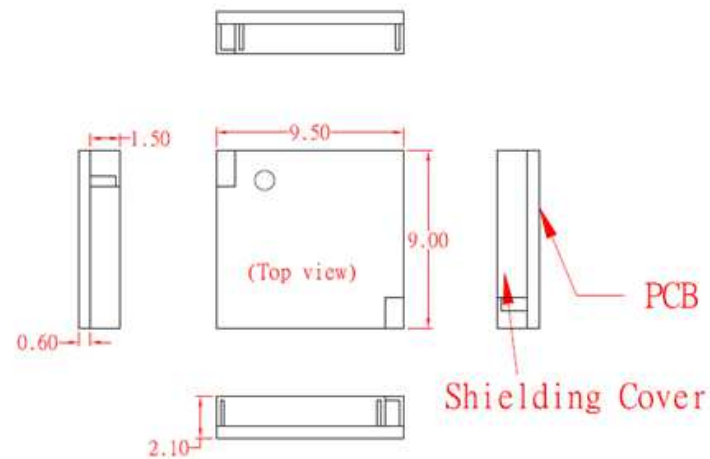

Figure 2-1: Mechanical Dimensions

Recommended PCB Pad Layout

(Unit: mm, Tolerance: 0.1mm)

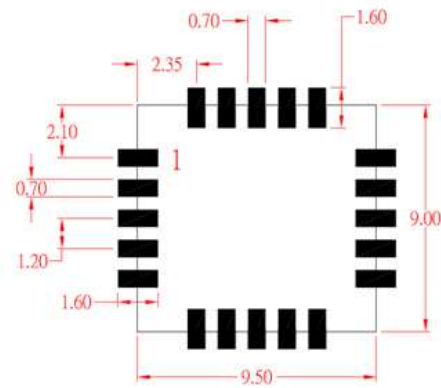

Figure 2-2: PCB Layout.

Pin Configuration

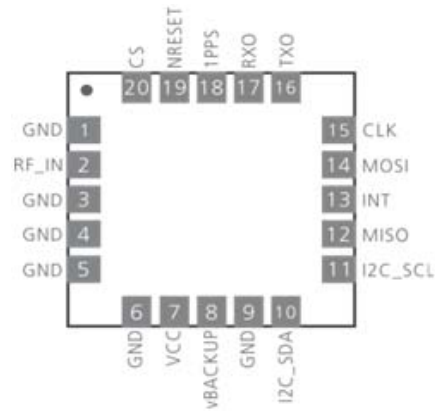

Figure 2-3: Pin Configuration. I2C_SCL and I2C_SDA pins are disabled by FW. Please keep them floating.

Pin Assignment

Table 2-1: Pin Assignment

Pin	Name	I/O	Description and Note
1	GND	P	Ground
2	RF_IN	I	GPS RF signal input
3	GND	P	Ground
4	GND	P	Ground
5	GND	P	Ground
6	GND	P	Ground
7	VCC	PI	Main DC power input
8	VBACKUP	PI	Backup power input for RTC & navigation data keep
9	GND	P	Ground
10	I2C_SDA ^a	I/O	I2C Serial data (in slave mode)
11	I2C_SCL ^a	I	I2C Serial clock (in slave mode)
12	MISO	O	SPI serial data output (in slave mode)
13	INT	O	Interrupt pin for SPI or I2C
14	MOSI	I	SPI serial data input (in slave mode)
15	CLK	I	SPI serial clock
16	TX0	O	Serial Data Output for NMEA output (TTL)
17	RX0	I	Serial Data Input for Firmware update (TTL)

Table 2-1: Pin Assignment

Pin	Name	I/O	Description and Note
18	1PPS	O	1PPS Time Mark Output 2.8V CMOS Level (Optional: pulse width can be customized) (Optional: customization definition)
19	NRESET	I	Reset Input, Low Active
20	CS	I	SPI serial chip select

a. Disabled by FW, please keep these pins floating.

Description of I/O Pins

- **Pin1:** GND (Ground)
- **Pin2:** RF_IN
 - The GPS RF signal input which can be connected to a passive antenna or an active antenna.
- **Pin3:** GND (Ground)
- **Pin4:** GND (Ground)
- **Pin5:** GND (Ground)
- **Pin6:** GND (Ground)
- **Pin7:** VCC
 - Main DC power supply (3.0V to 4.3V; typical: 3.3V). The ripple must be controlled under 50mVpp.
- **Pin8:** VBACKUP
 - This connects to the backup power of the GNSS module. A power source (such as a battery) connected to this pin will help the GNSS chipset in keeping its internal RTC running when the main power source is turned off. The voltage ranges from 2.0V~4.3V (typical: 3.0V).
 - If VBACKUP power is not reserved, the GNSS module will perform a lengthy cold start each time whenever it is powered on, as previous satellite information is not retained and needs to be re-transmitted.
 - If not used, keeps this pin floating.
- **Pin9:** GND (Ground)
- **Pin10:** I²C_SDA¹ (I²C; outputs GPS information/RTCM_TX)
- **Pin11:** I²C_SCL¹ (RTCM_RX)
 - This pin can be modified through firmware customization.
 - The *default* of this pin is defined to I²C_SCL. It will receive the clock for I²C application.
 - If the pin is customized to RTCM, it will receive DGPS data of RTCM protocol (TTL level).
 - If not used, keeps this pin floating.
- **Pin12:** MISO (SPI; outputs GPS information)
- **Pin13:** INT
 - This is the interrupt sync pin of the module. It is used to determine whether NMEA is stored in SPI/ I²C¹ buffer.
 - If NMEA data is ready and stored in SPI/ I²C¹ buffer, the pin will pull low.

1. Disabled by FW, please keep these pins floating.

- After entire NMEA packet of one second is read, the pin will pull high.
- **Pin14:** MOSI (SPI; to receive commands from system)
- **Pin15:** CLK (SPI; to receive clock time from system)
- **Pin16:** TX0 (UART 0 transmitter; outputs GPS information for application)
- **Pin17:** RX0 (UART 0 receiver; to receive commands from system)
- **Pin18:** 1PPS
 - This pin provides one pulse-per-second signal output. If not used, keeps this pin floating.
- **Pin19:** NRESET
 - **Active** on Low for the module to reset. If not used, keep this pin floating.

Table 2-2: NRESET

NRESET Level	Min(V)	Typ(V)	Max(V)
Low	0	0	1.5
High	2	2.8	3.3

- **Pin20:** CS (SPI; to select chip for system)
 - Active on Low to enable SPI

Specifications

Table 2-3: Specification Data

Description	
GNSS Solution	MTK MT3333 ^a
Frequency	GPS L1, 1575.42MHz GLONASS L1, 1598.0625~1605.375MHz
Sensitivity (GPS portion)	Acquisition: -148dBm, cold start Reacquisition: -163dBm, Hot start Tracking: -165dBm
SV Number GPS GLONASS	#1~32 #65~96 (see Chapter 3 for details)
TTFF (GPS, No. of SVs>4, C/ N>40dB, PDop<1.5)	Hot start: 1 second typical Warm start: 33 seconds typical Cold start: 35 seconds typical, 60 seconds Max
Position Accuracy	Without aid:3m (50% CEP) DGPS(SBAS(WAAS,EGNOS,MSAS, GAGAN ^b)):2.5m (50% CEP)
Velocity Accuracy	Without aid : 0.1m/s DGPS(SBAS(WAAS,EGNOS,MSAS, GAGAN ^b)):0.05m/s
Timing Accuracy (1PPS Output)	Default: ±20ns RMS within 100ms in one pulse (pulse width/duration can be customized)
Altitude	10,000m maximum (Normal mode: car/pedestrian/ aviation) 80,000m maximum (Balloon mode)
Velocity	Maximum 515m/s (1000 knots) ^c
Acceleration	Maximum 4G
Update Rate	1Hz (default), maximum 10Hz
Baud Rate	9600 bps (default)
DGPS	SBAS(default) [WAAS, EGNOS, MSAS, GAGAN ^b]
Power Supply	VCC: 3V to 4.3V; VBACKUP: 2.0V to 4.3V
Current Consumption @ 3.3V,1Hz Update Rate	GPS+GLONASS: Acquisition: 23mA/ 26mA /30mA (min / typical / max) Full Power Tracking: 21mA / 23mA /28mA (min / typical / max) GLP (GNSS low-power) Tracking : 7mA / 16mA / 32mA (min / typical / max)
Backup Power Consumption@ 3V	15uA (TYP)
Power Saving (Periodic)	Backup mode: 9uA(TYP) ^d Standby mode: 350uA(TYP) ^d
NRESET Current @ 3.3V	8mA(TYP)
Working Temperature	-40 °C to +85 °C

Table 2-3: Specification Data

Description	
Dimension	9.0x9.5 x 2.1 mm, SMD
Weight	0.4g

- RTCM is not enabled on this product
- GAGAN will be supported
- The number was simulated from lab test
- Please refer to PMTK 161 / 225

Absolute Maximum Ranges

Table 2-4: Maximum Ranges

	Symbol	Min.	Typ.	Max.	Unit
Power Supply Voltage	VCC	3.0	3.3	4.3	V
Backup Battery Voltage	VBACKUP	2.0	3.0	4.3	V

Operating Conditions

Table 2-5: Operating Conditions

	Condition	Min.	Typ.	Max.	Unit
Operation Supply Ripple Voltage	-	-	-	50	mVpp
RX0 TTL H Level	-	2.0	-	3.3	V
RX0 TTL L Level	-	0	-	0.8	V
TX0 TTL H Level	-	2.4	-	2.8	V
TX0 TTL L Level	-	0	-	0.4	V

>> 3: Protocols

NMEA Output Sentences

Table 3-1 lists all NMEA output sentences specifically developed and defined by MTK for MTK's products.

Table 3-1: Position Fix Indicator

Option	Description
GGA	Time, position and fix type data.
GSA	GNSS receiver operating mode, active satellites used in the position solution and DOP values.
GSV	The number of GPS satellites in view, satellite ID numbers, elevation, azimuth, and SNR values.
RMC	Time, date, position, course and speed data. The recommended minimum navigation information.
VTG	Course and speed information relative to the ground.

Table 3-2 lists NMEA output sentences used in GPS system and GLONASS system

Table 3-2: NMEA Output Sentence for GPS and GNSS

System	GGA	GSA	GSV	RMC	VTG
GPS	GPGGA	GPGSA	GPGSV	GPRMC	GPVTG
GNSS (GPS+GLONASS)	GNGGA	GPGSA GLGSA	GPGSV GLGSV ^a	GNRMC	GNVTG

a. In Talker ID, GP is a short term of "GPS"; GL is "GLONASS" and GN is "GPS +GLONASS"

GGA—Time, Position and Related Data of Navigation Fix

Table 3-3 explains the NMEA sentence below:

```
$GNGGA, 064951.000, 2307.1256, N, 12016.4438, E, 1, 8, 0.95,
39.9, M, 17.8, M, *65
```

Table 3-3: GGA Data Format

Name	Example	Units	Description
Message ID	\$GNGGA		GGA protocol header
UTC Time	064951.00 0		hhmmss.sss
Latitude	2307.1256		ddmm.mmmm

Table 3-3: GGA Data Format

Name	Example	Units	Description
N/S Indicator	N		N North or S South
Longitude	12016.443 8		dddmm.mmmm
E/W Indicator	E		E East or W West
Position Fix Indicator	1		See Table 3-4
Satellites Used	8		
HDOP	0.95		Horizontal Dilution of Precision
MSL Altitude	39.9	meters	Antenna Altitude above/below mean-sea-level
Units	M	meters	Units of antenna altitude
Geoidal Separation	17.8	meters	
Units	M	meters	Units of geoids separation
Age of Diff. Corr.		second	Null fields when DGPS is not used
Checksum	*65		
<CR> <LF>			End of message termination

Table 3-4: Position Fix Indicator

Value	Description
0	Fix not available
1	GPS Fix
2	Differential GPS Fix

*Note: when inputting the command \$PMTK353,0,1,0,0,0*2A, \$GNGGA will change to \$GLGGA (For GLONASS). When inputting the command \$PMTK353,1,0,0,0,0*2A, \$GNGGA will change to \$GPGGA (For GPS).*

GSA—GNSS DOP and Active Satellites, Including GPS(GPGSA) and GLONASS(GLGSA)

Table 3-5 explains the example NMEA sentence below:

GPS satellite system:

```
$GPGSA,A,3,29,21,26,15,18,09,06,10,,,,,2.32,0.95,2.11*00
```

GPS+GLONASS satellite system:

```
$GPGSA,A,3,08,28,20,04,32,17,11,,,,,1.00,0.63,0.77*1B (GPS  
satellite)
```

```
$GLGSA,A,3,77,76,86,78,65,88,87,71,72,,,,,1.00,0.63,0.77*17  
(GLONASS satellite)
```

Table 3-5: GGA Data Format

Name	Example	Units	Description
Message ID	\$GPGSA, or \$GLGSA		GSA protocol header
Mode 1	A		See Table 3-6
Mode 2	3		See Table 3-7
Satellite Used ^a	8		SV on Channel 1
Satellite Used	28		SV on Channel 2
....
Satellite Used			SV on Channel 12
PDOP	1		Position Dilution of Precision
HDOP	0.63		Horizontal Dilution of Precision
VDOP	0.77		Vertical Dilution of Precision
Checksum	*1B		
<CR> <LF>			End of message termination

a. GPS SV No. #01~#32
GLONASS SV No. #65~#96

Table 3-6: Mode 1

Value	Description
M	Manual—forced to operate in 2D or 3D mode
A	2D Automatic—allowing to switch to 2D/3D mode automatically

Table 3-7: Mode 2

Value	Description
1	Fix not available
2	2D (<4 SVs used)
3	3D (>=4 SVs used)

GSV— Satellites in View, Including GPS(GPGSV) and GLONASS(GLGSV)

Table 3-8 explains the example NMEA sentences below:

```
$GPGSV,4,1,14,28,75,321,44,42,54,137,39,20,53,080,44,17,40,30,44*77
$GPGSV,4,2,14,04,33,253,43,32,28,055,41,08,26,212,40,11,14,055,33*7F
$GPGSV,4,3,14,10,12,198,,07,06,179,38,23,04,125,44,27,02,314,*7E
$GPGSV,4,4,14,193,,,42,01,,,36*45
```

Table 3-8: GPGSV Data Format

Name	Example	Units	Description
Message ID	\$GPGSV		GSV protocol header
Number of Messages	4		(Depending on the number of satellites tracked, multiple messages of GSV data may be required) ^a
Message Number	1		
Satellites in View	14		
Satellite ID	28		Channel 1 (Range 1 to 32)
Elevation	75	degrees	Channel 1 (Maximum 90)
Azimuth	321	degrees	Channel 1 (True, Range 0 to 359)
SNR (C/No)	44	dB-Hz	Range 0 to 99, (null when not tracking)
....
Satellite ID	17		Channel 4 (Range 1 to 32)
Elevation	40	degrees	Channel 4 (Maximum 90)
Azimuth	330	degrees	Channel 4 (True, Range 0 to 359)
SNR (C/No)	44	dB-Hz	Range 0 to 99, (null when not tracking)

Table 3-8: GPGSV Data Format

Name	Example	Units	Description
Checksum	*77		
<CR> <LF>			End of message termination

a. One GSV sentence can only receive up to 4 SVs

Table 3-9 explains the example NMEA sentences below:

\$GLGSV, 4, 1, 15, 72, 45, 084, 40, 77, 39, 246, 44, 87, 36, 014, 44, 65, 33, 157, 36*62

\$GLGSV, 4, 2, 15, 78, 26, 306, 41, 88, 23, 315, 42, 76, 15, 192, 38, 86, 13, 067, 38*64

\$GLGSV, 4, 3, 15, 71, 12, 035, 38*54

Table 3-9: GLGSV Data Format

Name	Example	Units	Description
Message ID	\$GLGSV		GSV protocol header
Number of Messages	4		(Depending on the number of satellites tracked, multiple messages of GSV data may be required) ^a
Message Number	1		
Satellites in View	15		
Satellite ID	72		Channel 1 (Range 1 to 32)
Elevation	45	degrees	Channel 1 (Maximum 90)
Azimuth	84	degrees	Channel 1 (True, Range 0 to 359)
SNR (C/No)	40	dB-Hz	Range 0 to 99, (null when not tracking)
....
Satellite ID	44		Channel 4 (Range 1 to 32)
Elevation	65	degrees	Channel 4 (Maximum 90)
Azimuth	157	degrees	Channel 4 (True, Range 0 to 359)
SNR (C/No)	36	dB-Hz	Range 0 to 99, (null when not tracking)
Checksum	*62		
<CR> <LF>			End of message termination

a. One GSV sentence can only receive up to 4 SVs

RMC—Recommended Minimum Navigation Information

Table 3-10 explains the example NMEA sentence below:

```
$GNRMC,064951.000,A,2307.1256,N,12016.4438,E,0.03,165.48,260406,3.05,W,A*2C
```

Table 3-10: RMC Data Format

Name	Example	Units	Description
Message ID	\$GNRMC		RMC protocol header
UTC Time	064951.000		hhmmss.sss
Status	A		A: data valid V: data not valid
Latitude	2307.1256		ddmm.mmmm
N/S Indicator	N		N: North S: South
Longitude	12016.4438		dddmm.mmmm
E/W Indicator	E		E: East W: West
Speed over Ground	0.03	Knots/hr	
Course over Ground	165.48	degrees	TRUE
Date	260406		ddmmyy
Magnetic Variation	3.05, W	degrees	E: East W: West (By Customization)
Mode	A		A: Autonomous mode D: Differential mode E: Estimated mode
Checksum	*2C		
<CR> <LF>			End of message termination
Message ID	\$GNRMC		RMC protocol header

Note: when inputting the commend \$PMTK353,0,1,0,0,0*2A , \$GNRMC will change to \$GLRMC (for GLONASS). When inputting the commend \$PMTK353,1,0,0,0,0*2A : \$GNRMC will change to \$GPRMC (for GPS).

VTG—Course and Speed Information Relating to the Ground

Table 3-11 explains the example NMEA sentence below:

```
$GNVTG,165.48,T,,M,0.03,N,0.06,K,A*37
```

Table 3-11: VTG Data Format

Name	Example	Units	Description
Message ID	\$GNVTG		VTG protocol header
Course	165.48	degrees	Measured heading
Reference	T		TRUE
Course		degrees	Measured heading
Reference	M		Magnetic Variation (By Customization)
Speed	0.03	Knots/hr	Measured horizontal speed
Units	N		Knots
Speed	0.06	km/hr	Measured horizontal speed
Units	K		Kilometers per hour
Mode	A		A: Autonomous mode D: Differential mode E: Estimated mode
Checksum	*37		
<CR> <LF>			End of message termination

Note: when inputting the commend \$PMTK353,0,1,0,0,0*2A , \$GNVTG will change to \$GLVTG(For GLONASS). When inputting the commend \$PMTK353,1,0,0,0,0*2A : \$GNVTG will change to \$GPVTG (For GPS).

MTK NMEA Command Protocols

Packet Type: 103 PMTK_CMD_COLD_START

Packet Meaning: Cold Start --- Discarding the data of Time, Position, Almanacs and Ephemeris at re-start.

Example: \$PMTK103*30<CR><LF>

4: Reference Design

This section introduces the reference schematic design for best performance. Additional tips and cautions on design are well documented in the related Application Note that is available upon request.

Reference Schematic Design for Using the RTCM/I²C/SPI

The XM1110 provides several interfaces to process GNSS NMEA data (by specified firmware):

1. UART0¹ + RTCM (for DGPS data)
2. UART0¹ + I²C (for NMEA data)
3. UART0¹ + SPI (for NMEA data)

Schematic Reference Design for the RTCM

Figure 4-1 provides a schematic reference design for the RTCM:

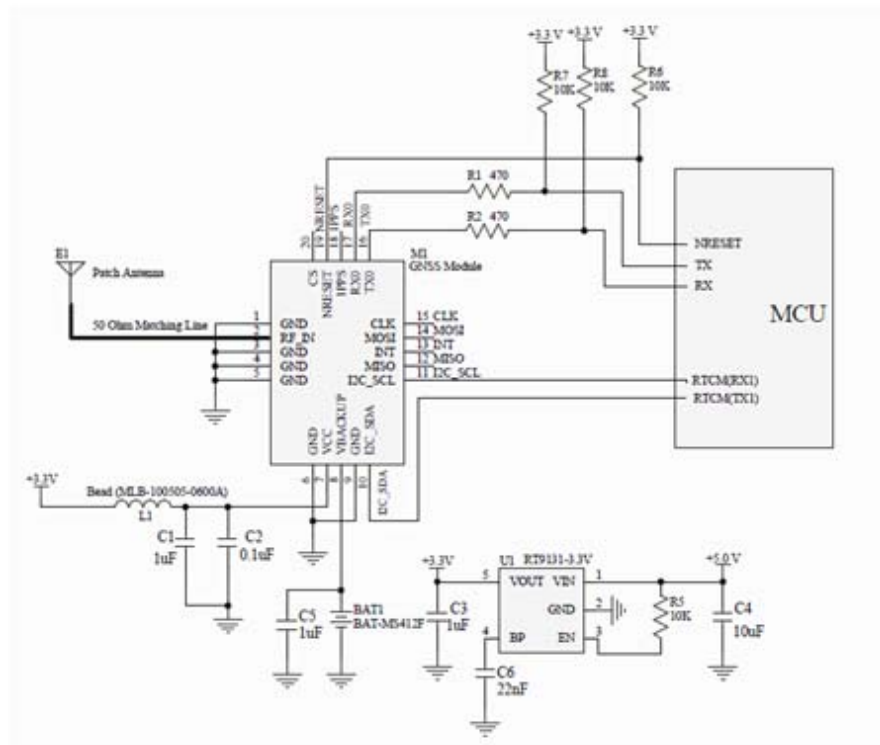

Figure 4-1: UART + RTCM

1. RTCM and I²C not supported on XM1110