



Chipsmall Limited consists of a professional team with an average of over 10 year of expertise in the distribution of electronic components. Based in Hongkong, we have already established firm and mutual-benefit business relationships with customers from,Europe,America and south Asia,supplying obsolete and hard-to-find components to meet their specific needs.

With the principle of “Quality Parts,Customers Priority,Honest Operation,and Considerate Service”,our business mainly focus on the distribution of electronic components. Line cards we deal with include Microchip,ALPS,ROHM,Xilinx,Pulse,ON,Everlight and Freescale. Main products comprise IC,Modules,Potentiometer,IC Socket,Relay,Connector.Our parts cover such applications as commercial,industrial, and automotives areas.

We are looking forward to setting up business relationship with you and hope to provide you with the best service and solution. Let us make a better world for our industry!



## Contact us

Tel: +86-755-8981 8866 Fax: +86-755-8427 6832

Email & Skype: info@chipsmall.com Web: www.chipsmall.com

Address: A1208, Overseas Decoration Building, #122 Zhenhua RD., Futian, Shenzhen, China





A New Direction in Mixed-Signal

# XR1008, XR2008

## 0.5mA, 75MHz Rail-to-Rail Amplifiers

### General Description

The XR1008 (single) and XR2008 (dual) are rail-to-rail output amplifiers that offer superior dynamic performance with 75MHz small signal bandwidth and 50V/ $\mu$ s slew rate. The XR1008 and XR2008 amplifiers consume only 505 $\mu$ A of supply current per channel and are designed to operate from a supply range of 2.5V to 5.5V ( $\pm 1.25$  to  $\pm 2.75$ ).

The combination of low power, high output current drive, and rail-to-rail performance make the XR1008 and XR2008 well suited for battery-powered metering and test equipment.

The combination of low cost and high performance make these amplifiers suitable for high volume industrial applications such as ultrasonic heat meters, water meters and other applications requiring high speed and low power.

### FEATURES

- 505 $\mu$ A supply current
- 75MHz bandwidth
- Input voltage range with 5V supply: -0.3V to 3.8V
- Output voltage range with 5V supply: 0.07V to 4.86V
- 50V/ $\mu$ s slew rate
- 12nV/ $\sqrt$ Hz input voltage noise
- 15mA linear output current
- Fully specified at 2.7V and 5V supplies

### APPLICATIONS

- Portable/battery-powered applications
- Mobile communications, cell phones, pagers
- ADC buffer
- Active filters
- Portable test instruments
- Signal conditioning
- Medical equipment
- Portable medical instrumentation
- Flow meters

Ordering Information - [back page](#)

### Typical Application

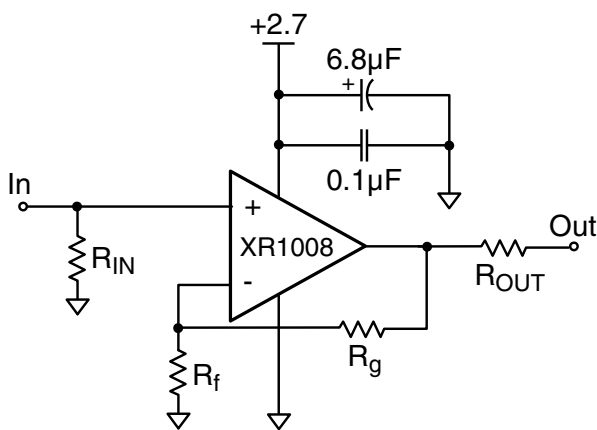

### Frequency Response vs. Temperature

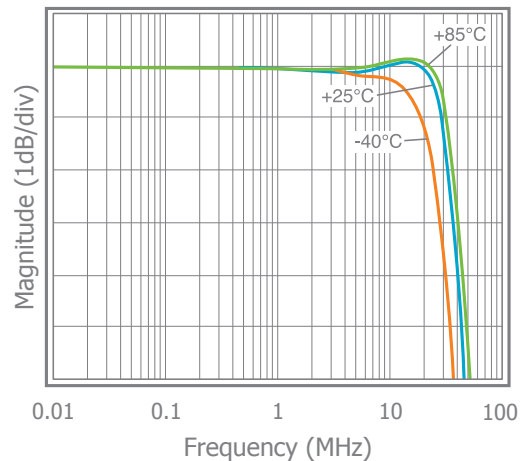

**Absolute Maximum Ratings**

Stresses beyond the limits listed below may cause permanent damage to the device. Exposure to any Absolute Maximum Rating condition for extended periods may affect device reliability and lifetime.

$V_S$  ..... 0V to 6V  
 $V_{IN}$  .....  $-V_S - 0.5V$  to  $+V_S + 0.5V$   
 Continuous Output Current ..... -30mA to +30mA

**Operating Conditions**

Supply Voltage Range .....2.5 to 5.5V  
 Operating Temperature Range .....-40°C to 125°C  
 Junction Temperature ..... 150°C  
 Storage Temperature Range.....-65°C to 150°C  
 Lead Temperature (Soldering, 10s) .....260°C

**Package Thermal Resistance**

$\theta_{JA}$  (TSOT-5) .....215°C/W  
 $\theta_{JA}$  (SOIC-8) ..... 150°C/W  
 $\theta_{JA}$  (MSOP-8) ..... 200°C/W  
 Package thermal resistance ( $\theta_{JA}$ ), JEDEC standard, multi-layer test boards, still air.

**ESD Protection**

XR1008 (HBM) .....2kV  
 XR2008 (HBM) .....2.5kV  
 ESD Rating for HBM (Human Body Model).

## Electrical Characteristics at +2.7V

$T_A = 25^\circ\text{C}$ ,  $V_S = +2.7\text{V}$ ,  $R_f = R_g = 1\text{k}\Omega$ ,  $R_L = 1\text{k}\Omega$  to  $V_S/2$ ;  $G = 2$ ; unless otherwise noted.

Symbol	Parameter	Conditions	Min	Typ	Max	Units
Frequency Domain Response						
UGBW <sub>SS</sub>	Unity Gain -3dB Bandwidth	$G = +1$ , $V_{OUT} = 0.05V_{pp}$ , $R_f = 0$		65		MHz
BW <sub>SS</sub>	-3dB Bandwidth	$G = +2$ , $V_{OUT} < 0.2V_{pp}$		30		MHz
BW <sub>LS</sub>	Large Signal Bandwidth	$G = +2$ , $V_{OUT} = 2V_{pp}$		12		MHz
GBWP	Gain Bandwidth Product	$G = +11$ , $V_{OUT} = 0.2V_{pp}$		28		MHz
Time Domain Response						
$t_R$ , $t_F$	Rise and Fall Time	$V_{OUT} = 0.2\text{V}$ step; (10% to 90%)		7.5		ns
$t_S$	Settling Time to 0.1%	$V_{OUT} = 1\text{V}$ step		60		ns
OS	Overshoot	$V_{OUT} = 1\text{V}$ step		10		%
SR	Slew Rate	$G = -1$ , $2\text{V}$ step		40		V/ $\mu\text{s}$
Distortion/Noise Response						
HD2	2nd Harmonic Distortion	1MHz, $V_{OUT} = 1V_{pp}$		-67		dBc
HD3	3rd Harmonic Distortion	1MHz, $V_{OUT} = 1V_{pp}$		-72		dBc
THD	Total Harmonic Distortion	1MHz, $V_{OUT} = 1V_{pp}$		65		dB
$e_n$	Input Voltage Noise	>10kHz		12		nV/ $\sqrt{\text{Hz}}$
DC Performance						
$V_{IO}$	Input Offset Voltage			0		mV
$d_{VIO}$	Average Drift			10		$\mu\text{V}/^\circ\text{C}$
$I_B$	Input Bias Current			1.2		$\mu\text{A}$
$dI_B$	Average Drift			3.5		nA/ $^\circ\text{C}$
$I_{OS}$	Input Offset Current			30		nA
PSRR	Power Supply Rejection Ratio	DC	60	66		dB
$A_{OL}$	Open Loop Gain	$V_{OUT} = V_S / 2$		98		dB
$I_S$	Supply Current	per channel		470		$\mu\text{A}$
Input Characteristics						
$R_{IN}$	Input Resistance	Non-inverting		9		M $\Omega$
$C_{IN}$	Input Capacitance			1.5		pF
CMIR	Common Mode Input Range			-0.3 to 1.5		V
CMRR	Common Mode Rejection Ratio	DC, $V_{CM} = 0\text{V}$ to $V_S - 1.5\text{V}$		74		dB
Output Characteristics						
$V_{OUT}$	Output Voltage Swing	$R_L = 1\text{k}\Omega$ to $V_S / 2$		0.09 to 2.53		V
		$R_L = 10\text{k}\Omega$ to $V_S / 2$		0.05 to 2.6		V
$I_{OUT}$	Output Current			$\pm 15$		mA
$I_{SC}$	Short Circuit Current			$\pm 30$		mA

## Electrical Characteristics at +5V

$T_A = 25^\circ\text{C}$ ,  $V_S = +5\text{V}$ ,  $R_f = R_g = 1\text{k}\Omega$ ,  $R_L = 1\text{k}\Omega$  to  $V_S/2$ ;  $G = 2$ ; unless otherwise noted.

Symbol	Parameter	Conditions	Min	Typ	Max	Units
Frequency Domain Response						
UGBW <sub>SS</sub>	Unity Gain -3dB Bandwidth	$G = +1$ , $V_{OUT} = 0.05V_{pp}$ , $R_f = 0$		75		MHz
BW <sub>SS</sub>	-3dB Bandwidth	$G = +2$ , $V_{OUT} < 0.2V_{pp}$		35		MHz
BW <sub>LS</sub>	Large Signal Bandwidth	$G = +2$ , $V_{OUT} = 2V_{pp}$		15		MHz
GBWP	Gain Bandwidth Product	$G = +11$ , $V_{OUT} = 0.2V_{pp}$		33		MHz
Time Domain Response						
$t_R$ , $t_F$	Rise and Fall Time	$V_{OUT} = 0.2\text{V}$ step; (10% to 90%)		6		ns
$t_S$	Settling Time to 0.1%	$V_{OUT} = 1\text{V}$ step		60		ns
OS	Overshoot	$V_{OUT} = 1\text{V}$ step		12		%
SR	Slew Rate	$G = -1$ , $2\text{V}$ step		50		V/ $\mu\text{s}$
Distortion/Noise Response						
HD2	2nd Harmonic Distortion	1MHz, $V_{OUT} = 2V_{pp}$		-64		dBc
HD3	3rd Harmonic Distortion	1MHz, $V_{OUT} = 2V_{pp}$		-62		dBc
THD	Total Harmonic Distortion	1MHz, $V_{OUT} = 2V_{pp}$		60		dB
$e_n$	Input Voltage Noise	>10kHz		12		nV/ $\sqrt{\text{Hz}}$
DC Performance						
$V_{IO}$	Input Offset Voltage		-5	-1	5	mV
$d_{VIO}$	Average Drift			10		$\mu\text{V}/^\circ\text{C}$
$I_B$	Input Bias Current		-3.5	1.2	3.5	$\mu\text{A}$
$dI_B$	Average Drift			3.5		nA/ $^\circ\text{C}$
$I_{OS}$	Input Offset Current			30	350	nA
PSRR	Power Supply Rejection Ratio	DC	60	66		dB
$A_{OL}$	Open Loop Gain	$V_{OUT} = V_S / 2$	65	80		dB
$I_S$	Supply Current	per channel		505	620	$\mu\text{A}$
Input Characteristics						
$R_{IN}$	Input Resistance	Non-inverting		9		M $\Omega$
$C_{IN}$	Input Capacitance			1.5		pF
CMIR	Common Mode Input Range			-0.3 to 3.8		V
CMRR	Common Mode Rejection Ratio	DC, $V_{CM} = 0\text{V}$ to $V_S - 1.5\text{V}$	65	74		dB
Output Characteristics						
$V_{OUT}$	Output Voltage Swing	$R_L = 1\text{k}\Omega$ to $V_S / 2$	0.2 to 4.65	0.13 to 4.73		V
		$R_L = 10\text{k}\Omega$ to $V_S / 2$		0.08 to 4.84		V
$I_{OUT}$	Output Current			$\pm 15$		mA
$I_{SC}$	Short Circuit Current			$\pm 30$		mA

### XR1008 Pin Configurations

#### TSOT-5

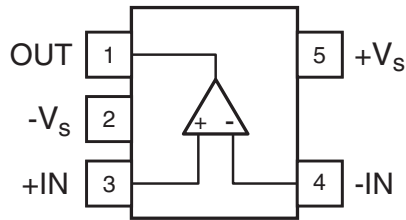

### XR1008 Pin Assignments

#### TSOT-5

Pin No.	Pin Name	Description
1	OUT	Output
2	-Vs	Negative supply
3	+IN	Positive input
4	-IN	Negative input
5	+Vs	Positive supply

#### SOIC-8

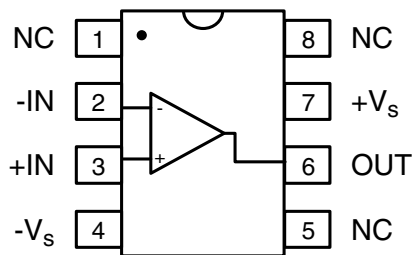

#### SOIC-8

Pin No.	Pin Name	Description
1	NC	No Connect
2	-IN	Negative input
3	+IN	Positive input
4	-Vs	Negative supply
5	NC	No Connect
6	OUT	Output
7	+Vs	Positive supply
8	NC	No Connect

### XR2008 Pin Configuration

#### SOIC-8 / MSOP-8

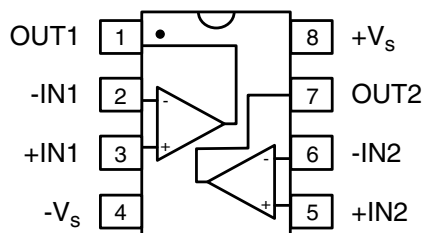

### XR2008 Pin Assignments

#### SOIC-8 / MSOP-8

Pin No.	Pin Name	Description
1	OUT1	Output, channel 1
2	-IN1	Negative input, channel 1
3	+IN1	Positive input, channel 1
4	-Vs	Negative supply
5	+IN2	Positive input, channel 2
6	-IN2	Negative input, channel 2
7	OUT2	Output, channel 2
8	+Vs	Positive supply

**Typical Performance Characteristics**

$T_A = 25^\circ\text{C}$ ,  $V_S = +5\text{V}$ ,  $R_f = R_g = 1\text{k}\Omega$ ,  $R_L = 1\text{k}\Omega$  to  $V_S/2$ ;  $G = 2$ ; unless otherwise noted.

Non-Inverting Frequency Response at  $V_S = 5\text{V}$

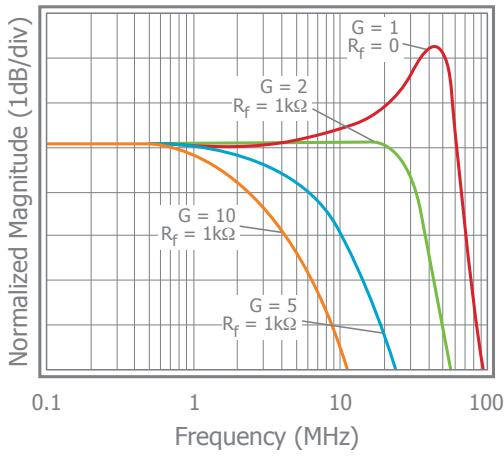

Inverting Frequency Response at  $V_S = 5\text{V}$

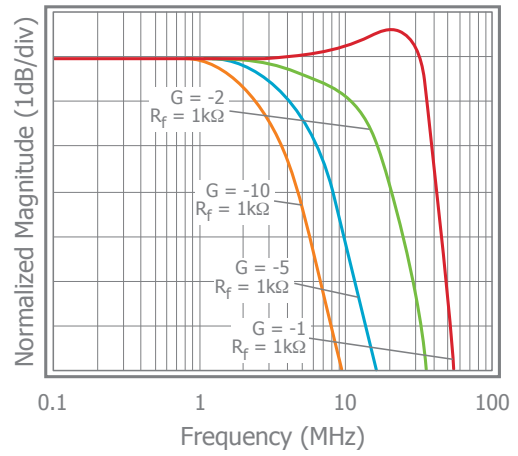

Non-Inverting Frequency Response at  $V_S = 2.7\text{V}$

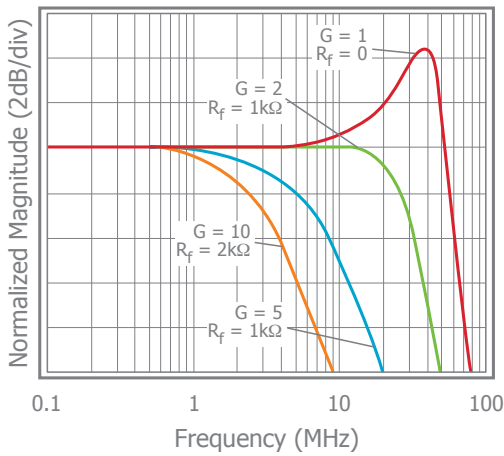

Inverting Frequency Response at  $V_S = 2.7\text{V}$

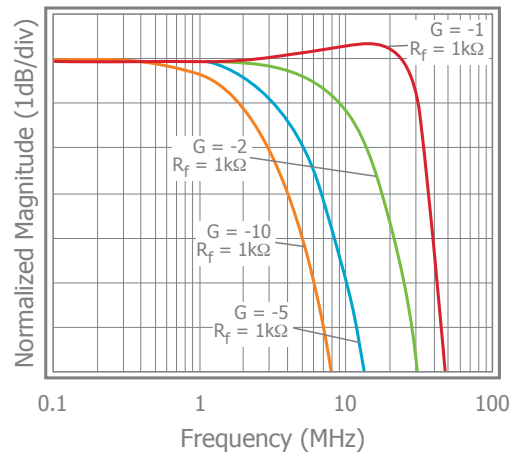

Frequency Response vs  $C_L$

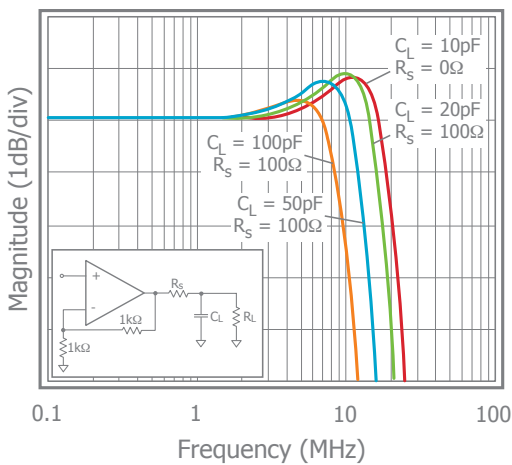

Frequency Response vs  $R_L$

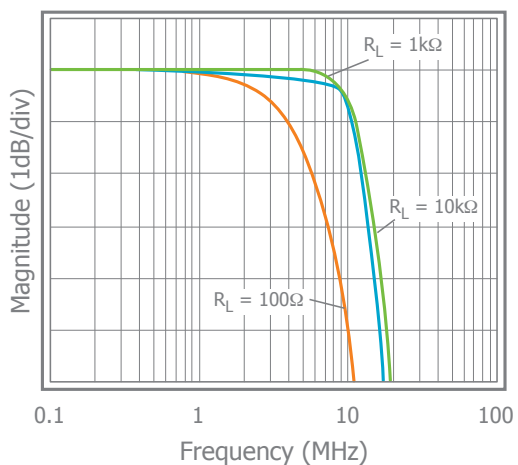

### Typical Performance Characteristics

$T_A = 25^\circ\text{C}$ ,  $V_S = +5\text{V}$ ,  $R_f = R_g = 1\text{k}\Omega$ ,  $R_L = 1\text{k}\Omega$  to  $V_S/2$ ;  $G = 2$ ; unless otherwise noted.

Frequency Response vs.  $V_{OUT}$

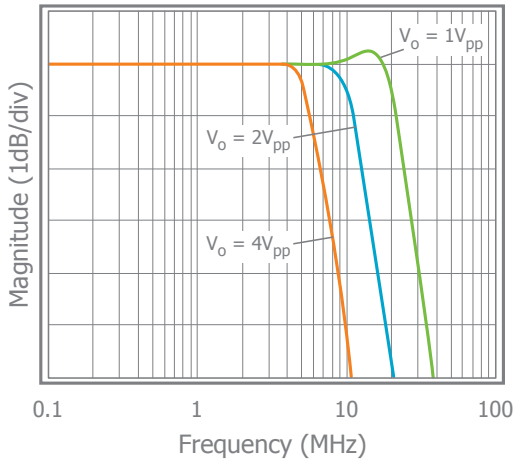

Open Loop Gain & Phase vs. Frequency

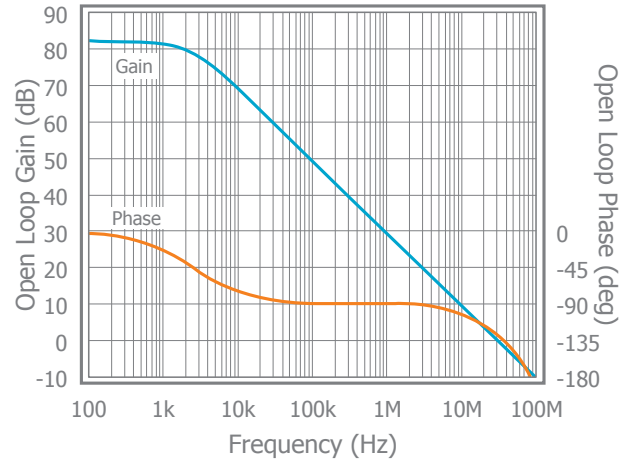

2nd Harmonic Distortion vs  $V_{OUT}$

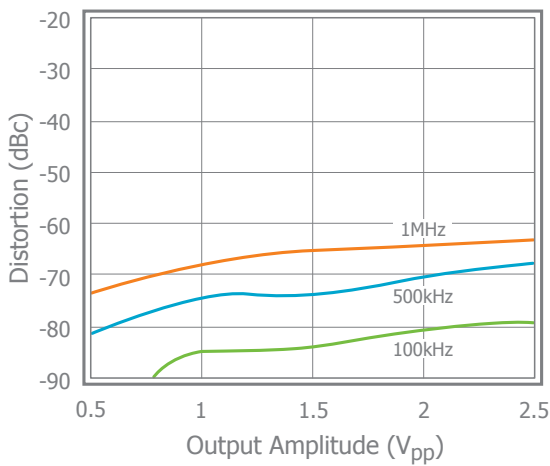

3rd Harmonic Distortion vs  $V_{OUT}$

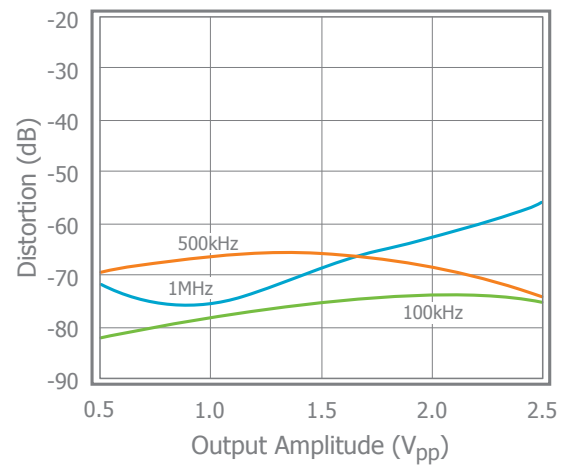

2nd & 3rd Harmonic Distortion at  $V_S = 2.7\text{V}$

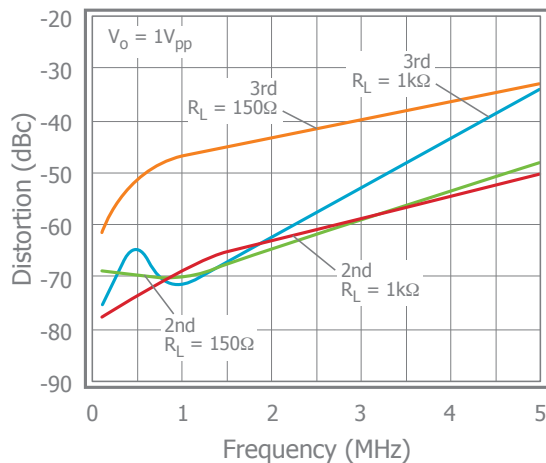

Frequency Response vs. Temperature

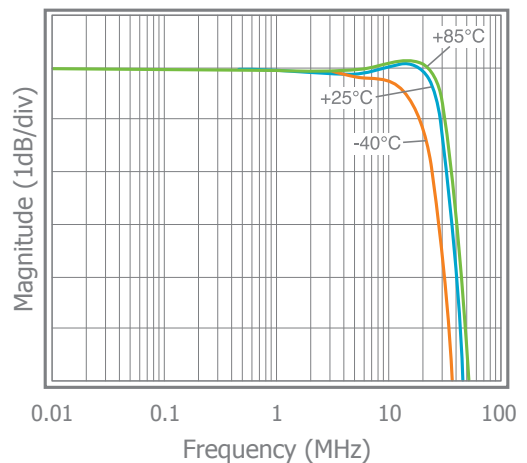



### Typical Performance Characteristics

$T_A = 25^\circ\text{C}$ ,  $V_S = +5\text{V}$ ,  $R_f = R_g = 1\text{k}\Omega$ ,  $R_L = 1\text{k}\Omega$  to  $V_S/2$ ;  $G = 2$ ; unless otherwise noted.

CMRR

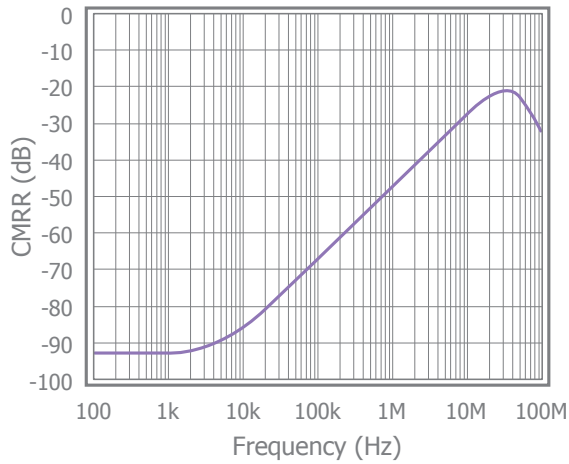

PSRR

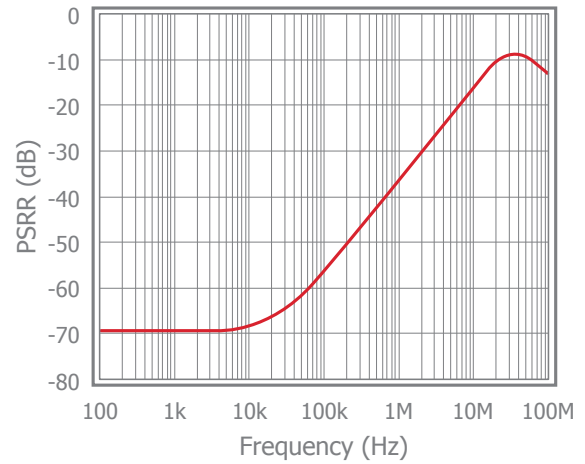

Output Swing

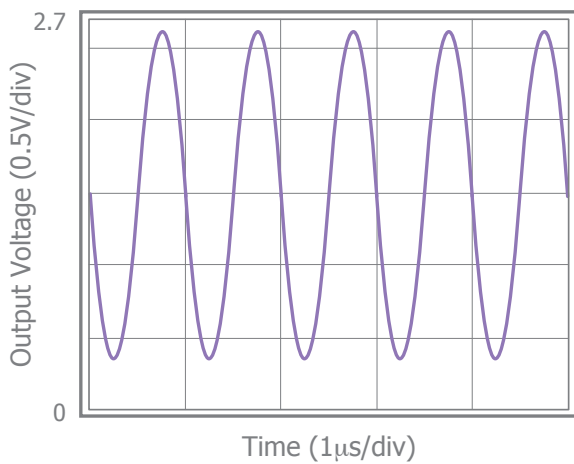

Output Voltage vs. Output Current

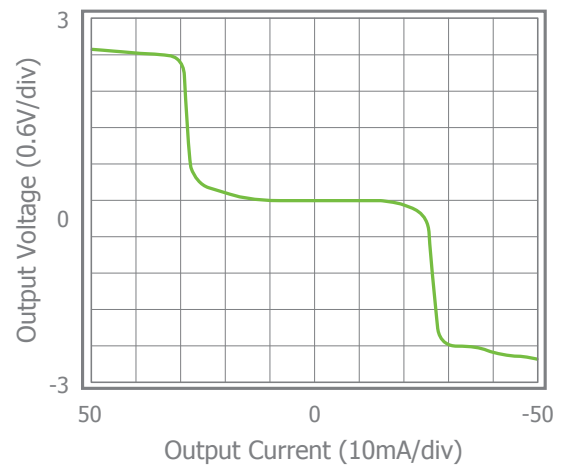

Small Signal Pulse Response at  $V_S = 2.7\text{V}$

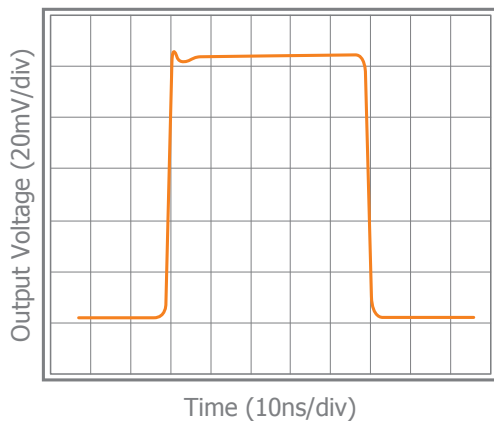

Small Signal Pulse Response at  $V_S = 5\text{V}$

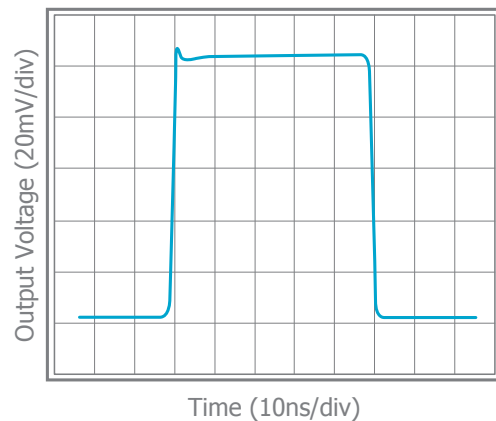

### Typical Performance Characteristics

$T_A = 25^\circ\text{C}$ ,  $V_S = +5\text{V}$ ,  $R_f = R_g = 1\text{k}\Omega$ ,  $R_L = 1\text{k}\Omega$  to  $V_S/2$ ;  $G = 2$ ; unless otherwise noted.

Large Signal Pulse Response at  $V_S = 5\text{V}$

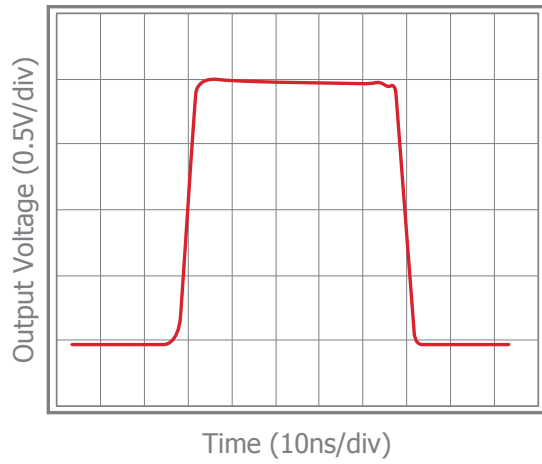

Input Voltage Noise

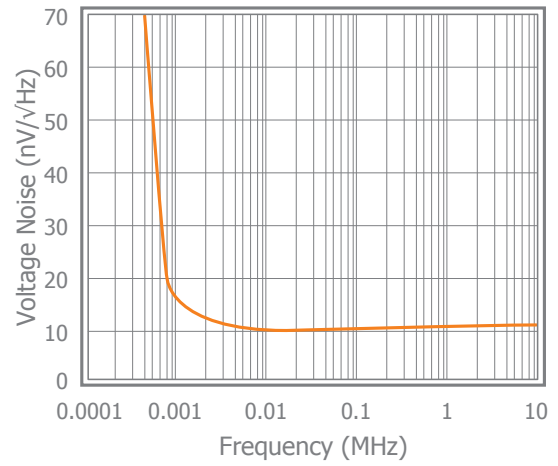

## Application Information

### General Description

The XR1008 family are a single supply, general purpose, voltage-feedback amplifiers fabricated on a complementary bipolar process. The XR1008 offers 75MHz unity gain bandwidth, 50V/μs slew rate, and only 505μA supply current. It features a rail-to-rail output stage and is unity gain stable.

Figures 1, 2, and 3 illustrate typical circuit configurations for non-inverting, inverting, and unity gain topologies for dual supply applications. They show the recommended bypass capacitor values and overall closed loop gain equations. Figure 4 shows the typical non-inverting gain circuit for single supply applications.

The common mode input range extends to 300mV below ground in single supply operation. Exceeding these values will not cause phase reversal. However, if the input voltage exceeds the rails by more than 0.5V, the input ESD devices will begin to conduct.

The design uses a Darlington output stage. The output stage is short circuit protected and offers “soft” saturation protection that improves recovery time.

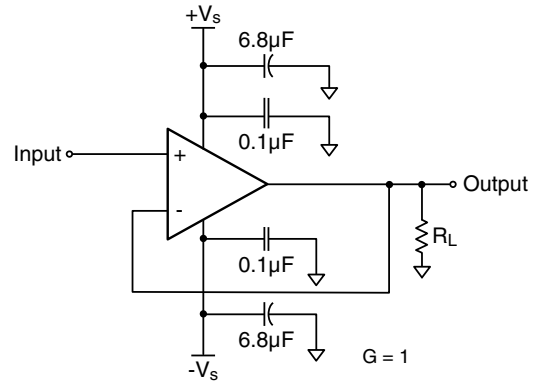

Figure 3: Unity Gain Circuit

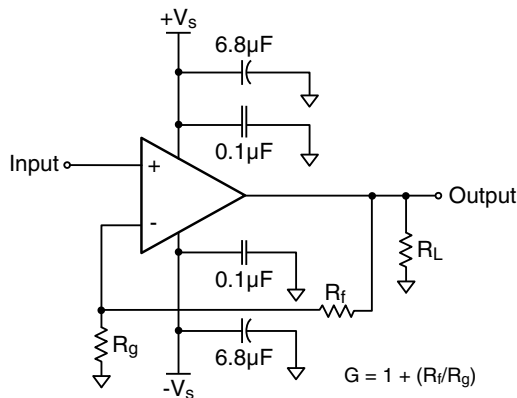

Figure 1: Typical Non-Inverting Gain Circuit

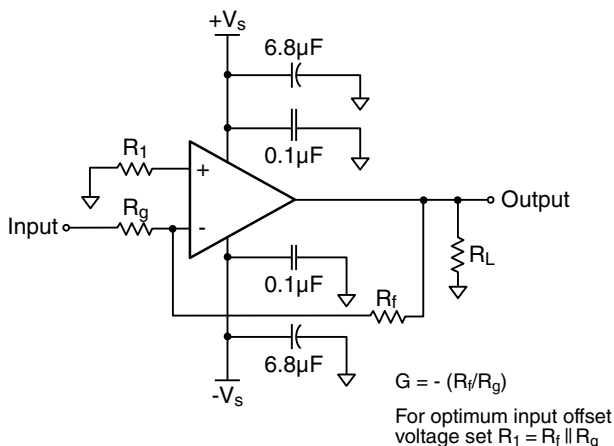

Figure 2: Typical Inverting Gain Circuit

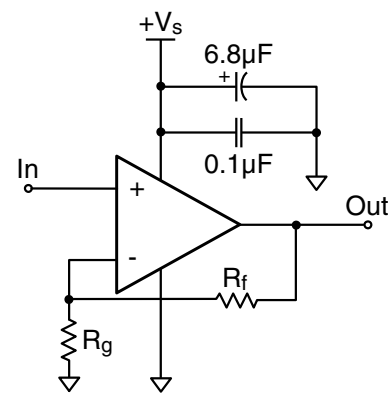

Figure 4: Single Supply Non-Inverting Gain Circuit

For optimum response at a gain of +2, a feedback resistor of 1kΩ is recommended. Figure 5 illustrates the XR1008 frequency response with both 1kΩ and 2kΩ feedback resistors.

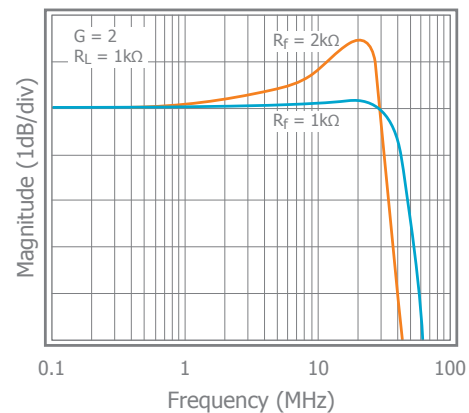

Figure 5: Frequency Response vs. R<sub>f</sub>

**Power Dissipation**

Power dissipation should not be a factor when operating under the stated 1kΩ load condition. However, applications with low impedance, DC coupled loads should be analyzed to ensure that maximum allowed junction temperature is not exceeded. Guidelines listed below can be used to verify that the particular application will not cause the device to operate beyond its intended operating range.

Maximum power levels are set by the absolute maximum junction rating of 150°C. To calculate the junction temperature, the package thermal resistance value  $\theta_{JA}$  ( $\theta_{JA}$ ) is used along with the total die power dissipation.

$$T_{\text{Junction}} = T_{\text{Ambient}} + (\theta_{JA} \times P_D)$$

Where  $T_{\text{Ambient}}$  is the temperature of the working environment.

In order to determine  $P_D$ , the power dissipated in the load needs to be subtracted from the total power delivered by the supplies.

$$P_D = P_{\text{supply}} - P_{\text{load}}$$

Supply power is calculated by the standard power equation.

$$P_{\text{supply}} = V_{\text{supply}} \times I_{\text{RMSsupply}}$$

$$V_{\text{supply}} = V_{S+} - V_{S-}$$

Power delivered to a purely resistive load is:

$$P_{\text{load}} = ((V_{\text{load}})_{\text{RMS}})^2 / R_{\text{load}_{\text{eff}}}$$

The effective load resistor ( $R_{\text{load}_{\text{eff}}}$ ) will need to include the effect of the feedback network. For instance,

$R_{\text{load}_{\text{eff}}}$  in Figure 3 would be calculated as:

$$R_L \parallel (R_f + R_g)$$

These measurements are basic and are relatively easy to perform with standard lab equipment. For design purposes however, prior knowledge of actual signal levels and load impedance is needed to determine the dissipated power. Here,  $P_D$  can be found from

$$P_D = P_{\text{Quiescent}} + P_{\text{Dynamic}} - P_{\text{load}}$$

Quiescent power can be derived from the specified  $I_S$  values along with known supply voltage,  $V_{\text{supply}}$ . Load power can be calculated as above with the desired signal amplitudes using:

$$(V_{\text{load}})_{\text{RMS}} = V_{\text{peak}} / \sqrt{2}$$

$$(I_{\text{load}})_{\text{RMS}} = (V_{\text{load}})_{\text{RMS}} / R_{\text{load}_{\text{eff}}}$$

The dynamic power is focused primarily within the output stage driving the load. This value can be calculated as:

$$P_{\text{Dynamic}} = (V_{S+} - V_{\text{load}})_{\text{RMS}} \times (I_{\text{load}})_{\text{RMS}}$$

Assuming the load is referenced in the middle of the power rails or  $V_{\text{supply}}/2$ .

The XR1008 is short circuit protected. However, this may not guarantee that the maximum junction temperature (+150°C) is not exceeded under all conditions. Figure 6 shows the maximum safe power dissipation in the package vs. the ambient temperature for the packages available.

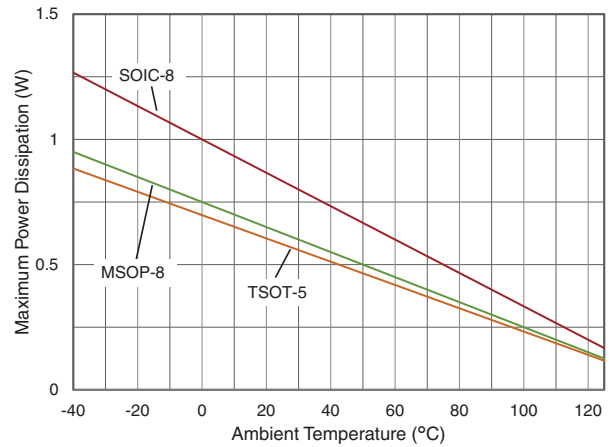

Figure 6. Maximum Power Derating

**Driving Capacitive Loads**

Increased phase delay at the output due to capacitive loading can cause ringing, peaking in the frequency response, and possible unstable behavior. Use a series resistance,  $R_S$ , between the amplifier and the load to help improve stability and settling performance. Refer to Figure 7.

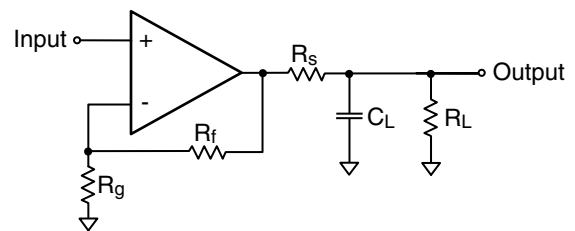

Figure 7. Addition of  $R_S$  for Driving Capacitive Loads

Table 1 provides the recommended  $R_S$  for various capacitive loads. The recommended  $R_S$  values result in approximately <1dB peaking in the frequency response.

$C_L$ (pF)	$R_S$ ( $\Omega$ )	-3dB BW (MHz)
10pF	0	22
20pF	100	19
50pF	100	12
100pF	100	10.2

Table 1: Recommended  $R_S$  vs.  $C_L$

For a given load capacitance, adjust  $R_S$  to optimize the tradeoff between settling time and bandwidth. In general, reducing  $R_S$  will increase bandwidth at the expense of additional overshoot and ringing.

### Overdrive Recovery

For an amplifier, an overdrive condition occurs when the output and/or input ranges are exceeded. The recovery time varies based on whether the input or output is overdriven and by how much the ranges are exceeded. The XR1008, and XR2008 will typically recover in less than 20ns from an overdrive condition. Figure 5 shows the XR1008 in an overdriven condition.

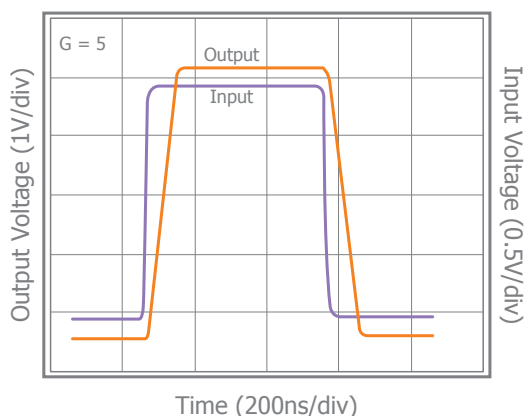

Figure 8: Overdrive Recovery

### Layout Considerations

General layout and supply bypassing play major roles in high frequency performance. Exar has evaluation boards to use as a guide for high frequency layout and as an aid in device testing and characterization. Follow the steps below as a basis for high frequency layout:

- Include 6.8 $\mu$ F and 0.1 $\mu$ F ceramic capacitors for power supply decoupling
- Place the 6.8 $\mu$ F capacitor within 0.75 inches of the power pin
- Place the 0.1 $\mu$ F capacitor within 0.1 inches of the power pin
- Remove the ground plane under and around the part, especially near the input and output pins to reduce parasitic capacitance
- Minimize all trace lengths to reduce series inductances

Refer to the evaluation board layouts below for more information.

### Evaluation Board Information

The following evaluation boards are available to aid in the testing and layout of these devices:

Evaluation Board #	Products
CEB002	XR1008 in TSOT
CEB003	XR1008 in SOIC
CEB006	XR2008 in SOIC
CEB010	XR2008 in MSOP

### Evaluation Board Schematics

Evaluation board schematics and layouts are shown in Figures 9-18. These evaluation boards are built for dual-supply operation. Follow these steps to use the board in a single-supply application:

1. Short  $-V_S$  to ground.
2. Use C3 and C4, if the  $-V_S$  pin of the amplifier is not directly connected to the ground plane.

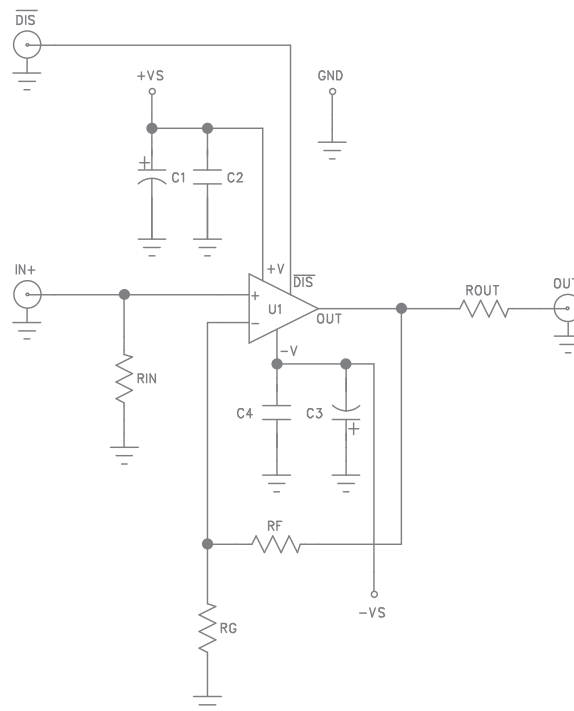

Figure 9. CEB002 & CEB003 Schematic

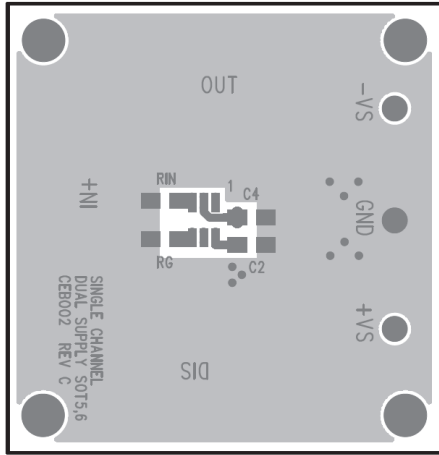

Figure 10. CEB002 Top View

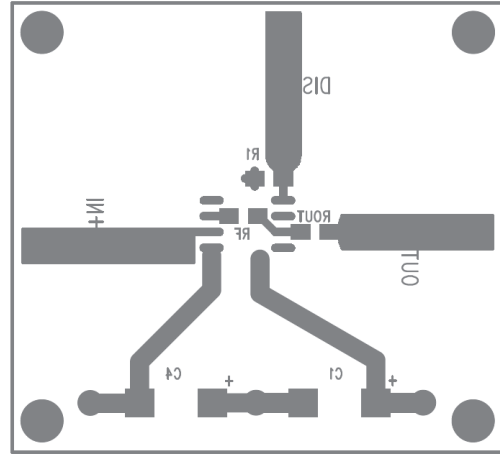

Figure 13. CEB003 Bottom View

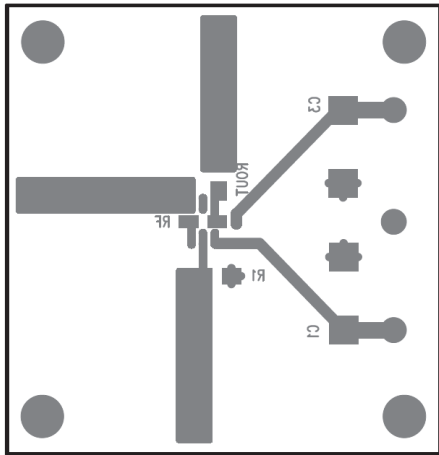

Figure 11. CEB002 Bottom View

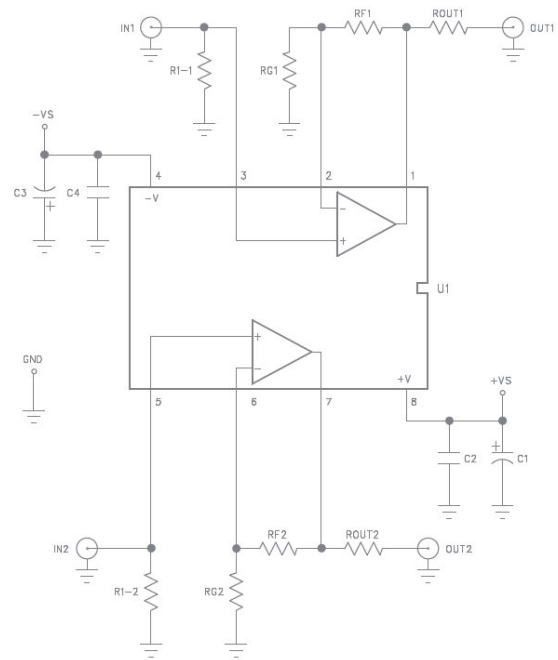

Figure 14. CEB006 & CEB010 Schematic

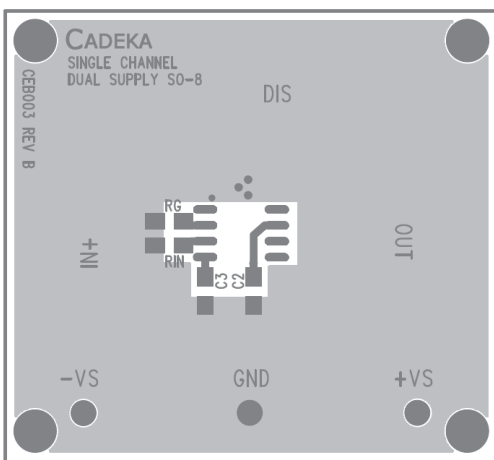

Figure 12. CEB003 Top View

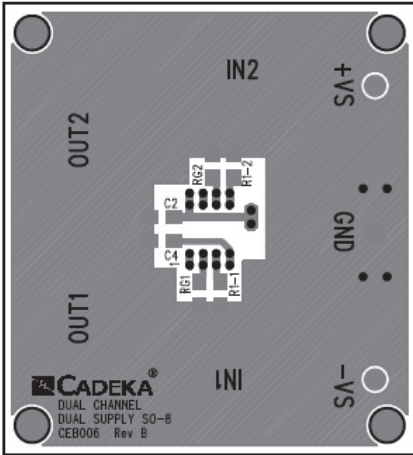

Figure 15. CEB006 Top View

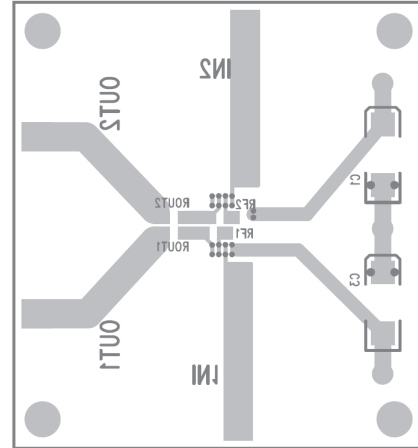

Figure 18. CEB010 Bottom View

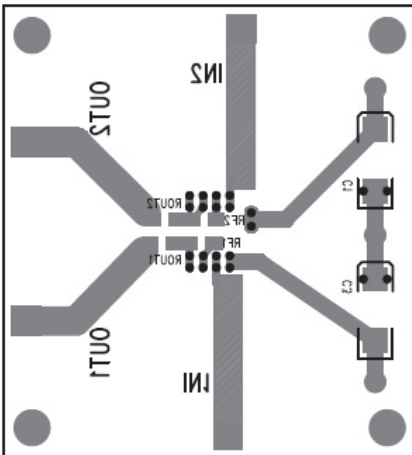

Figure 16. CEB006 Bottom View

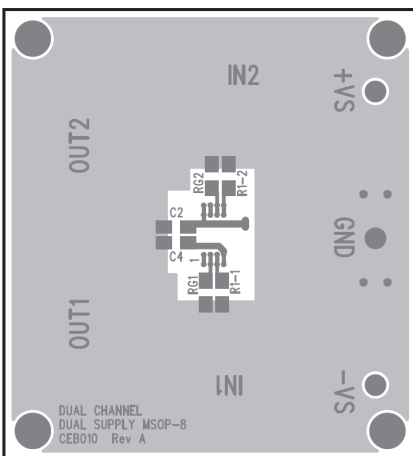
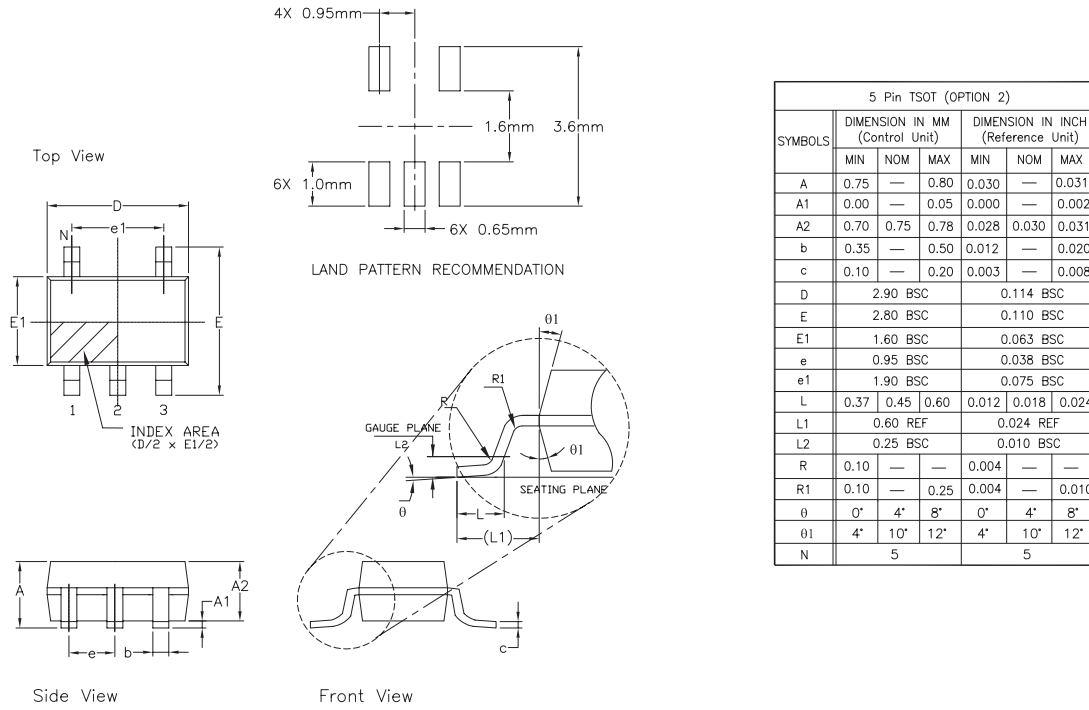

Figure 17. CEB010 Top View

## Mechanical Dimensions

### TSOT-5 Package



### MSOP-8 Package

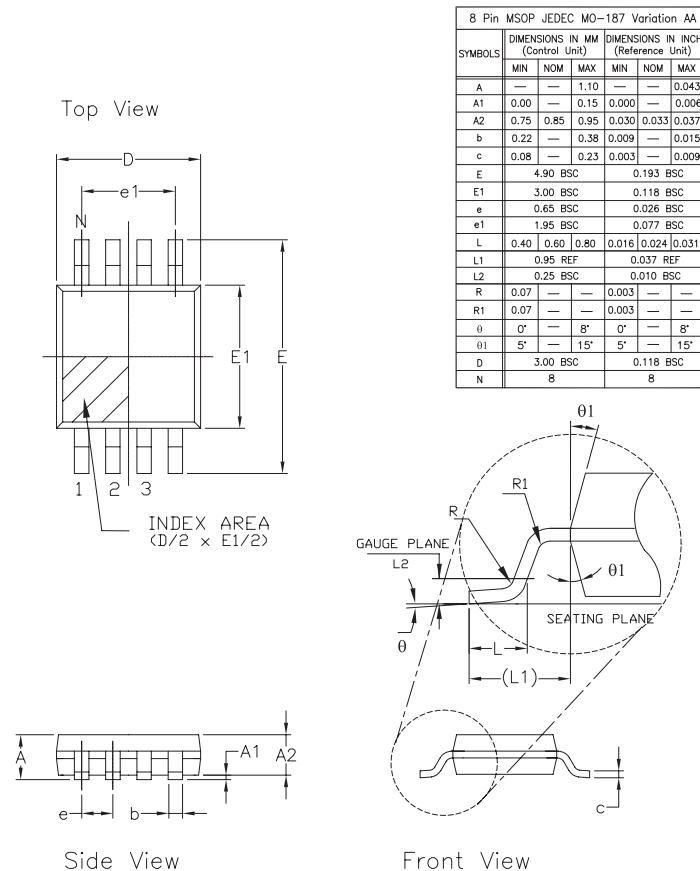



SOIC-8 Package

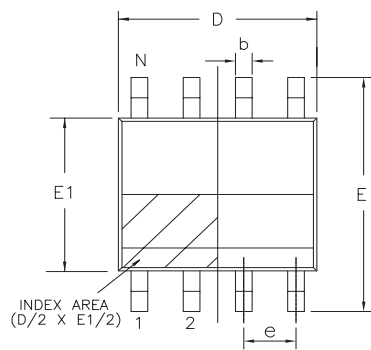

Top View

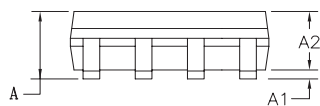

Side View

RECOMMENDED PCB LAND PATTERN

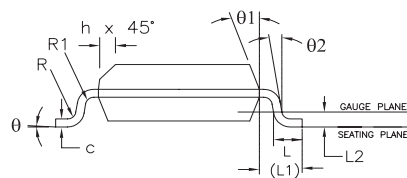
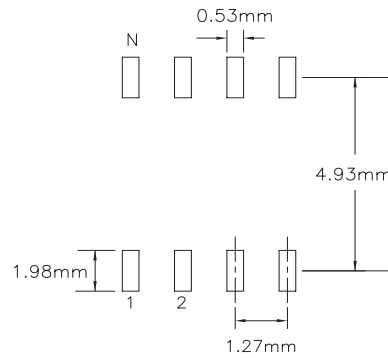

Front View

8 Pin SOICN JEDEC MS-012 Variation AA						
SYMBOLS	DIMENSIONS IN MM (Control Unit)			DIMENSIONS IN INCH (Reference Unit)		
	MIN	NOM	MAX	MIN	NOM	MAX
A	1.35	—	1.75	0.053	—	0.069
A1	0.10	—	0.25	0.004	—	0.010
A2	1.25	—	1.65	0.049	—	0.065
b	0.31	—	0.51	0.012	—	0.020
c	0.17	—	0.25	0.007	—	0.010
E	6.00 BSC		—	0.236 BSC		—
E1	3.90 BSC		—	0.154 BSC		—
e	1.27 BSC		—	0.050 BSC		—
h	0.25	—	0.50	0.010	—	0.020
L	0.40	—	1.27	0.016	—	0.050
L1	1.04 REF		—	0.041 REF		—
L2	0.25 BSC		—	0.010 BSC		—
R	0.07	—	—	0.003	—	—
R1	0.07	—	—	0.003	—	—
θ	0°	—	8°	0°	—	8°
θ1	5°	—	15°	5°	—	15°
θ2	0°	—	—	0°	—	—
D	4.90 BSC		—	0.193 BSC		—
N	8		—	8		—

## Ordering Information

Part Number	Package	Green	Operating Temperature Range	Packaging Quantity	Marking
XR1008 Ordering Information					
XR1008IST5X	TSOT-5	Yes	-40°C to +125°C	2.5k Tape & Reel	TC
XR1008IST5MTR	TSOT-5	Yes	-40°C to +125°C	250 Tape & Reel	TC
XR1008IST5EVB	Evaluation Board	N/A	N/A	N/A	N/A
XR1008ISO8X	SOIC-8	Yes	-40°C to +125°C	2.5k Tape & Reel	XR1008
XR1008ISO8MTR	SOIC-8	Yes	-40°C to +125°C	250 Tape & Reel	XR1008
XR1008ISO8EVB	Evaluation Board	N/A	N/A	N/A	N/A
XR2008 Ordering Information					
XR2008ISO8X	SOIC-8	Yes	-40°C to +125°C	2.5k Tape & Reel	XR2008
XR2008ISO8MTR	SOIC-8	Yes	-40°C to +125°C	250 Tape & Reel	XR2008
XR2008ISO8EVB	Evaluation Board	N/A	N/A	N/A	N/A
XR2008IMP8X	MSOP-8	Yes	-40°C to +125°C	2.5k Tape & Reel	2008
XR2008IMP8MTR	MSOP-8	Yes	-40°C to +125°C	250 Tape & Reel	2008
XR2008IMP8EVB	Evaluation Board	N/A	N/A	N/A	N/A

Moisture sensitivity level for all parts is MSL-1.

## Revision History

Revision	Date	Description
1A	June 2014	Initial Release [ECN1426-09   6/24/14]
1B	Sept 2014	Added XR1008 ESD, increased operating temperature range, updated package outline drawings, and removed Preliminary note on XR1008. [ECN1436-02   9/4/14]

### For Further Assistance:

Email: [CustomerSupport@exar.com](mailto:CustomerSupport@exar.com) or [HPATechSupport@exar.com](mailto:HPATechSupport@exar.com)

Exar Technical Documentation: <http://www.exar.com/techdoc/>

#### Exar Corporation Headquarters and Sales Offices

48760 Kato Road  
Fremont, CA 94538 - USA

Tel.: +1 (510) 668-7000  
Fax: +1 (510) 668-7001



A New Direction in Mixed-Signal

### NOTICE

EXAR Corporation reserves the right to make changes to the products contained in this publication in order to improve design, performance or reliability. EXAR Corporation assumes no responsibility for the use of any circuits described herein, conveys no license under any patent or other right, and makes no representation that the circuits are free of patent infringement. Charts and schedules contained here in are only for illustration purposes and may vary depending upon a user's specific application. While the information in this publication has been carefully checked; no responsibility, however, is assumed for inaccuracies.

EXAR Corporation does not recommend the use of any of its products in life support applications where the failure or malfunction of the product can reasonably be expected to cause failure of the life support system or to significantly affect its safety or effectiveness. Products are not authorized for use in such applications unless EXAR Corporation receives, in writing, assurances to its satisfaction that: (a) the risk of injury or damage has been minimized; (b) the user assumes all such risks; (c) potential liability of EXAR Corporation is adequately protected under the circumstances.

Reproduction, in part or whole, without the prior written consent of EXAR Corporation is prohibited.