



Chipsmall Limited consists of a professional team with an average of over 10 year of expertise in the distribution of electronic components. Based in Hongkong, we have already established firm and mutual-benefit business relationships with customers from,Europe,America and south Asia,supplying obsolete and hard-to-find components to meet their specific needs.

With the principle of “Quality Parts,Customers Priority,Honest Operation,and Considerate Service”,our business mainly focus on the distribution of electronic components. Line cards we deal with include Microchip,ALPS,ROHM,Xilinx,Pulse,ON,Everlight and Freescale. Main products comprise IC,Modules,Potentiometer,IC Socket,Relay,Connector.Our parts cover such applications as commercial,industrial, and automotives areas.

We are looking forward to setting up business relationship with you and hope to provide you with the best service and solution. Let us make a better world for our industry!



## Contact us

Tel: +86-755-8981 8866 Fax: +86-755-8427 6832

Email & Skype: info@chipsmall.com Web: www.chipsmall.com

Address: A1208, Overseas Decoration Building, #122 Zhenhua RD., Futian, Shenzhen, China



**FEATURES**

- Excellent Temperature Stability (20ppm/°C)
- Linear Frequency Sweep
- Wide Sweep Range (1000:1 Minimum)
- Wide Supply Voltage Range ( $\pm 4V$  to  $\pm 13V$ )
- Low Supply Sensitivity (0.1% /V)
- Wide Frequency Range (0.01Hz to 1MHz)
- Simultaneous Triangle and Squarewave Outputs

**APPLICATIONS**

- Voltage and Current-to-Frequency Conversion
- Stable Phase-Locked Loop
- Waveform Generation  
Triangle, Sawtooth, Pulse, Squarewave
- FM and Sweep Generation

**GENERAL DESCRIPTION**

The XR-2209 is a monolithic voltage-controlled oscillator (VCO) integrated circuit featuring excellent frequency stability and a wide tuning range. The circuit provides simultaneous triangle and squarewave outputs over a frequency range of 0.01Hz to 1MHz. It is ideally suited for FM, FSK, and sweep or tone generation, as well as for

phase-locked loop applications.

The oscillator of the XR-2209 has a typical drift specification of 20ppm/°C. The oscillator frequency can be linearly swept over a 1000:1 range with an external control voltage.

**ORDERING INFORMATION**

Part No.	Package	Operating Temperature Range
XR-2209CN	8 Lead 300 Mil CDIP	0° to +70°C
XR-2209M	8 Lead 300 Mil CDIP	-55°C to +125°C
XR-2209CP	8 Lead 300 Mil PDIP	0°C to +70°C

**BLOCK DIAGRAM**

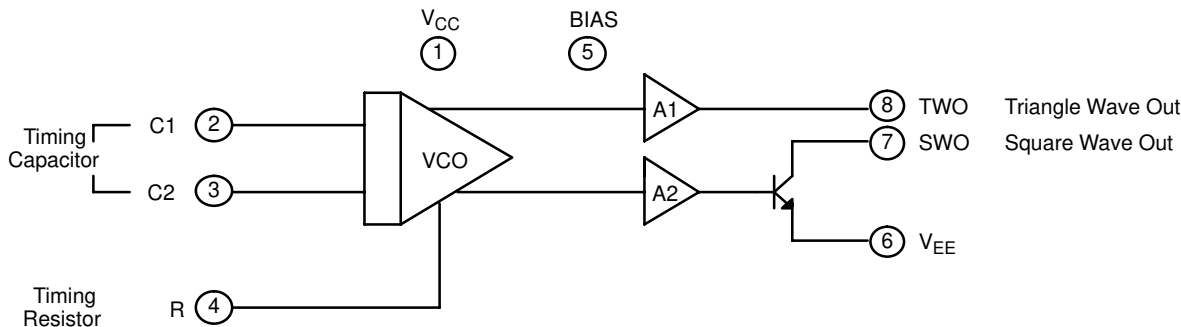
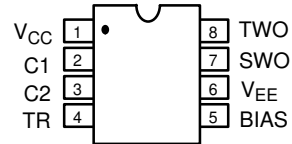


Figure 1. XR-2209 Block Diagram

## PIN CONFIGURATION



8 Lead PDIP, CDIP (0.300")

## PIN DESCRIPTION

Pin #	Symbol	Type	Description
1	V <sub>CC</sub>		Positive Power Supply.
2	C1	I	Timing Capacitor Input.
3	C2	I	Timing Capacitor Input.
4	TR	I	Timing Resistor.
5	BIAS	I	Bias Input for Single Supply Operation.
6	V <sub>EE</sub>		Negative Power Supply.
7	SWO	O	Square Wave Output Signal.
8	TWO	O	Triangle Wave Output Signal.

## DC ELECTRICAL CHARACTERISTICS

**Test Conditions:** Test Circuit of *Figure 3* and *Figure 4*,  $V_{CC} = 12V$ ,  $T_A = +25^\circ C$ ,  $C = 5000pF$ ,  $R = 20k\Omega$ ,  $R_L = 4.7k\Omega$ ,  $S_1$  and  $S_2$  Closed Unless Otherwise Specified

Parameters	XR-2209M			XR-2209C			Units	Conditions
	Min.	Typ.	Max.	Min.	Typ.	Max.		
<b>General Characteristics</b>								
Supply Voltage	8		26	8		26	V	See <i>Figure 3</i>
Single Supply	$\pm 4$		$\pm 13$	$\pm 4$		$\pm 13$	V	<i>Figure 4</i>
Supply Current								<i>Figure 3</i>
Single Supply		5	7		5	8	mA	Measured at Pin 1, $S_1$ , $S_2$ Open
Split Supplies								<i>Figure 4</i>
Positive		5	7		5	8	mA	Measured at Pin 1, $S_1$ , $S_2$ Open
Negative		4	6		4	7	mA	Measured at Pin 4, $S_1$ , $S_2$ Open
<b>Oscillator Section - Frequency Characteristics</b>								
Upper Frequency Limit	<b>0.5</b>	1.0		<b>0.5</b>	1.0		MHz	$C = 500pF$ , $R = 2K\Omega$
Lowest Practical Frequency		0.01			0.01		Hz	$C = 50\mu F$ , $R = 2M\Omega$
Frequency Accuracy		$\pm 1$	$\pm 3$		$\pm 1$	$\pm 5$	% of $f_0$	
Frequency Stability								
Temperature		20	50		30		ppm/ $^\circ C$	$0^\circ C < T_A < 70^\circ C$
Power Supply		0.15			0.15		%/V	
Sweep Range	<b>1000:1</b>	3000:1		<b>1000:1</b>			$f_H/f_L$	$R = 1.5 K\Omega$ for $f_H$ $R = 2M\Omega$ for $f_L$
Sweep Linearity								
10:1 Sweep		1	2		1.5		%	$f_H = 10kHz$ , $f_L = 1kHz$
1000:1 Sweep		5			5		%	$f_H = 100kHz$ , $f_L = 100Hz$
FM Distortion		0.1			0.1		%	$\pm 10\%$ FM Deviation
Recommended Range of Timing Resistor	<b>1.5</b>		<b>2000</b>	<b>1.5</b>		<b>2000</b>	$k\Omega$	See Characteristic Curves
Impedance at Timing Pins		75			75		$\Omega$	Measured at Pin 4
<b>Output Characteristics</b>								
Triangle Output								Measured at Pin 8
Amplitude	<b>4</b>	6		<b>4</b>	6		$V_{pp}$	
Impedance		10			10		$\Omega$	
DC Level		+100			+100		mV	Referenced to Pin 6
Linearity		0.1			0.1		%	From 10% to 90% of Swing
Squarewave Output								Measured at Pin 7, $S_2$ Closed
Amplitude	<b>11</b>	12		<b>11</b>	12		$V_{pp}$	
Saturation Voltage		0.2	0.4		0.2	<b>0.4</b>	V	Referenced to Pin 6
Rise Time		200			200		nsec	$C_L \leq 10pF$ , $R_L = 4.7K$
Fall Time		20			20		nsec	$C_L \leq 10pF$

### Notes

**Bold face parameters** are covered by production test and guaranteed over operating temperature range.

Specifications are subject to change without notice

## ABSOLUTE MAXIMUM RATINGS

Power Supply ..... 26V  
 Power Dissipation (package limitation)  
 Ceramic package ..... 750mW  
 Derate above +25°C ..... 10mW/°C

Plastic package ..... 600mW  
 Derate above +25°C ..... 8mW/°C  
 SOIC package ..... 300mW  
 Derate above +25°C ..... 4mW/°C  
 Storage Temperature Range ..... -65°C to +150°C

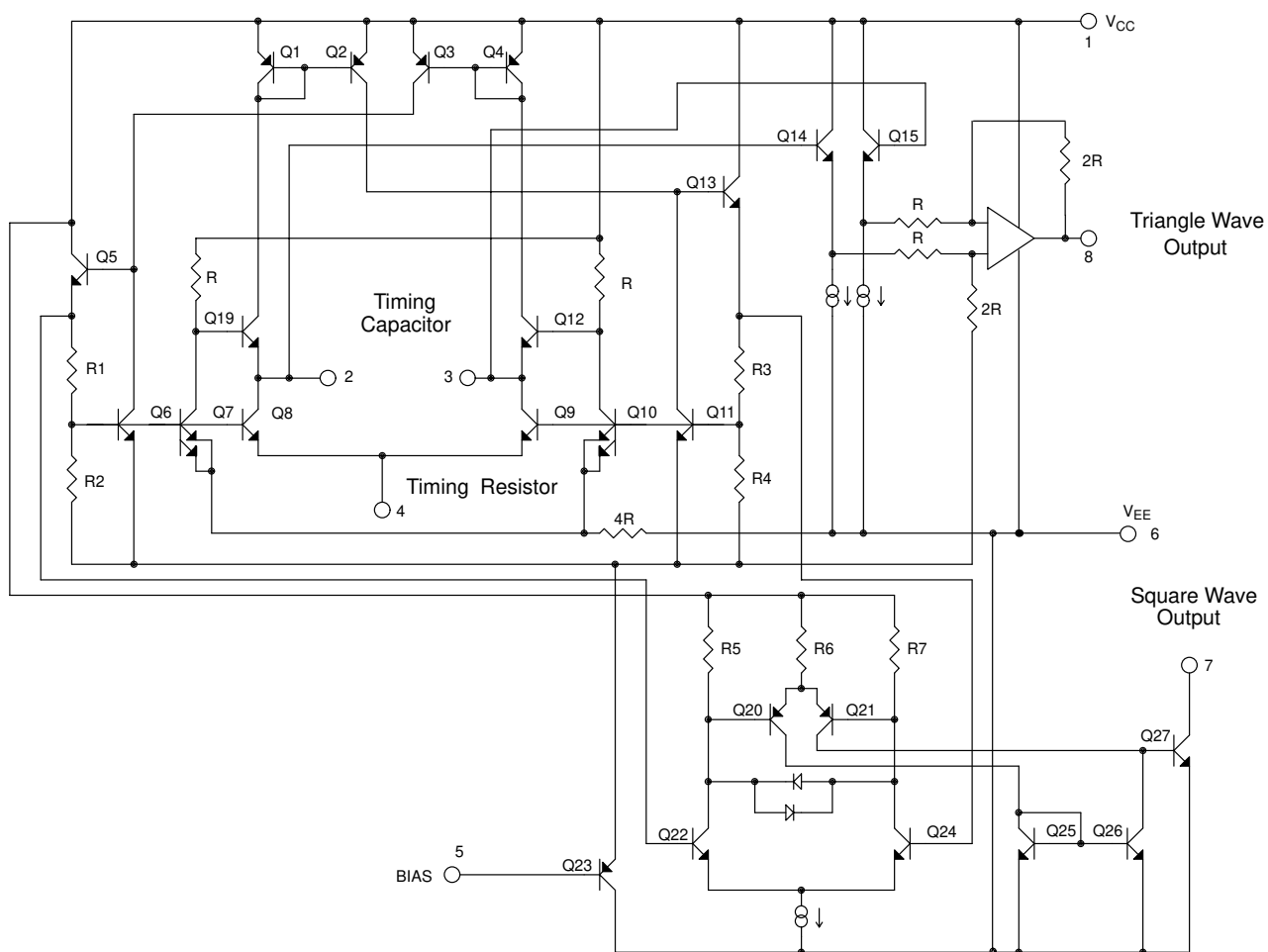


Figure 2. Equivalent Schematic Diagram

**PRECAUTIONS**

The following precautions should be observed when operating the XR-2209 family of integrated circuits:

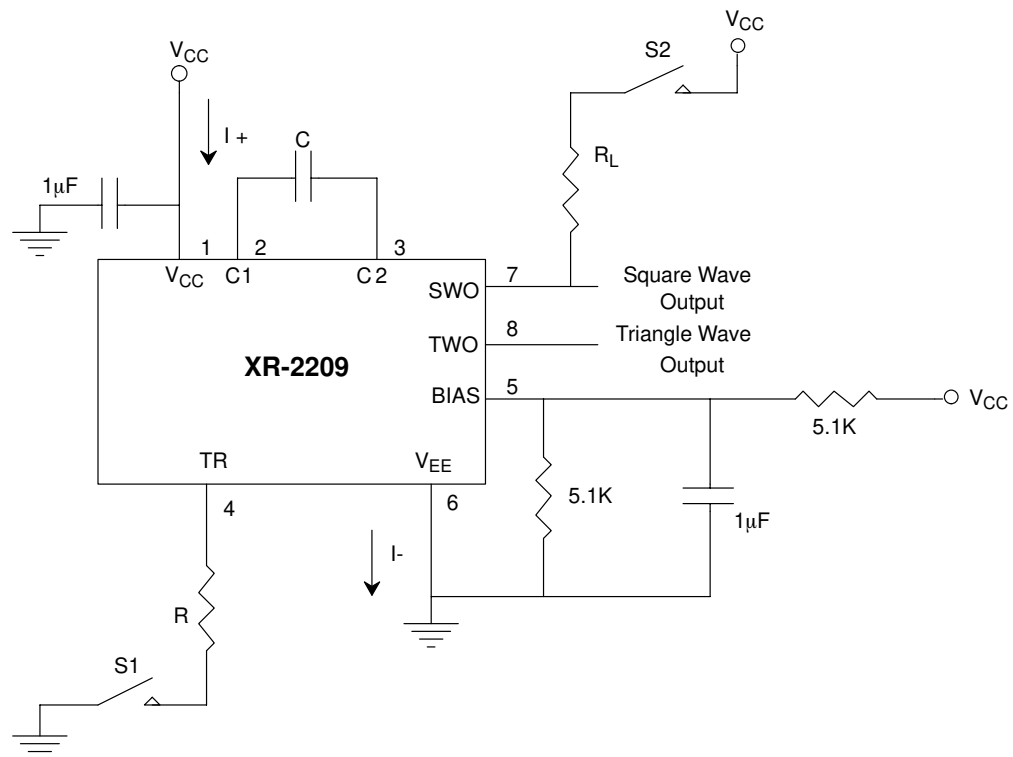
1. Pulling excessive current from the timing terminals will adversely affect the temperature stability of the circuit. To minimize this disturbance, it is recommended that the total current drawn from pin 4 be limited to  $\leq 6\text{mA}$ . In addition, permanent damage to the device may occur if the total timing current exceeds 10mA.
2. Terminals 2, 3, and 4 have very low internal impedance and should, therefore, be protected from accidental shorting to ground or the supply voltage.

**SYSTEM DESCRIPTION**

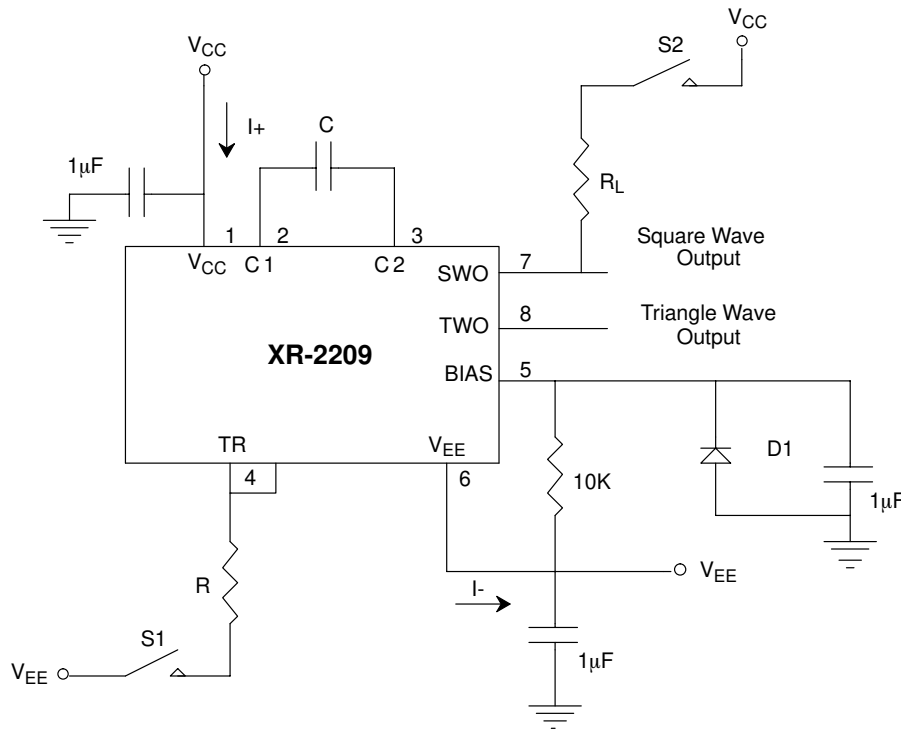
The XR-2209 functional blocks are shown in the block diagram given in *Figure 1*. They are a voltage controlled oscillator (VCO), and two buffer amplifiers for triangle and squarewave outputs. *Figure 2* is a simplified XR-2209 schematic diagram that shows the circuit in greater detail.

The VCO is a modified emitter-coupled current controlled multivibrator. Its oscillation is inversely proportional to the value of the timing capacitor connected to pins 2 and 3, and directly proportional to the total timing current  $I_T$ . This current is determined by the resistor that is connected from the timing terminals (pin 4) to ground.

The triangle output buffer has a low impedance output ( $10\Omega$  typ.) while the squarewave is an open-collector type. An external bias input allows the XR-2209 to be used in either single or split supply applications.



**Figure 3. Test Circuit for Single Supply Operation**



**Figure 4. Test Circuit for Split Supply Operation**

## OPERATING CONSIDERATIONS

### Supply Voltage (Pins 1 and 6)

The XR-2209 is designed to operate over a power supply range of  $\pm 4\text{V}$  to  $\pm 13\text{V}$  for split supplies, or 8V to 26V for single supplies. *Figure 5* shows the permissible supply voltage for operation with unequal split supply voltages. *Figure 6* and *Figure 7* show supply current versus supply voltage. Performance is optimum for  $\pm 6\text{V}$  split supply, or 12V single supply operation. At higher supply voltages, the frequency sweep range is reduced.

### Ground (Pin 6)

For split supply operation, this pin serves as circuit ground. For single supply operation, pin 6 should be ac grounded through a  $1\mu\text{F}$  bypass capacitor. During split supply operation, a ground current of  $2 I_T$  flows out of this terminal, where  $I_T$  is the total timing current.

### Bias for Single Supply (Pin 5)

For single supply operation, pin 5 should be externally biased to a potential between  $V_{CC}/3$  and  $V_{CC}/2V$  (see *Figure 3*.) The bias current at pin 5 is nominally 5% of the total oscillation timing current,  $I_T$ .

### Bypass Capacitors

The recommended value for bypass capacitors is  $1\mu\text{F}$  although larger values are required for very low frequency operation.

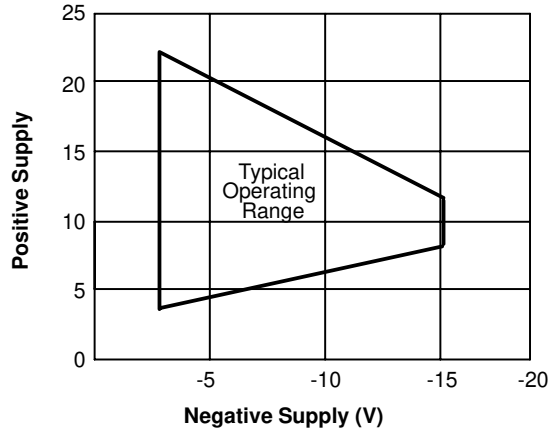
### Timing Resistor (Pin 4)

The timing resistor determines the total timing current,  $I_T$ , available to charge the timing capacitor. Values for the timing resistor can range from  $2\text{k}\Omega$  to  $2\text{M}\Omega$ ; however, for optimum temperature and power supply stability, recommended values are  $4\text{k}\Omega$  to  $200\text{k}\Omega$  (see *Figure 8*, *Figure 9*, *Figure 10* and *Figure 11*.) To avoid parasitic pick up, timing resistor leads should be kept as short as possible.

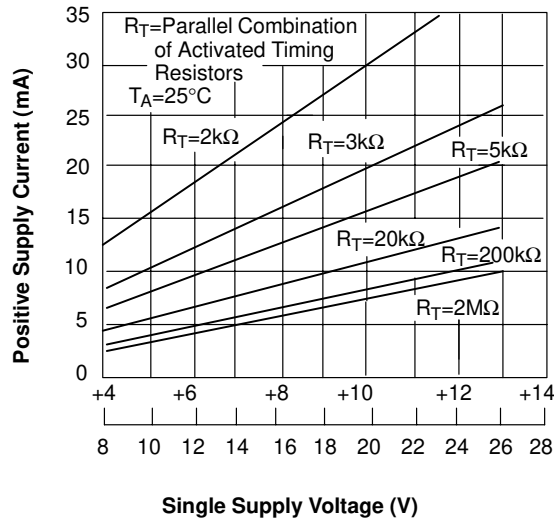
**Timing Capacitor (Pins 2 and 3)**

The oscillator frequency is inversely proportional to the timing capacitor, C. The minimum capacitance value is limited by stray capacitances and the maximum value by

physical size and leakage current considerations. Recommended values range from 100pF to 100μF. The capacitor should be non-polarized.

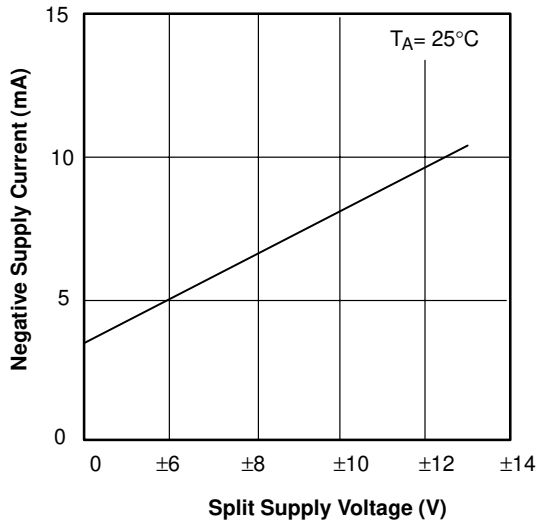


**Figure 5. Operating Range for Unequal Split Supply Voltages**

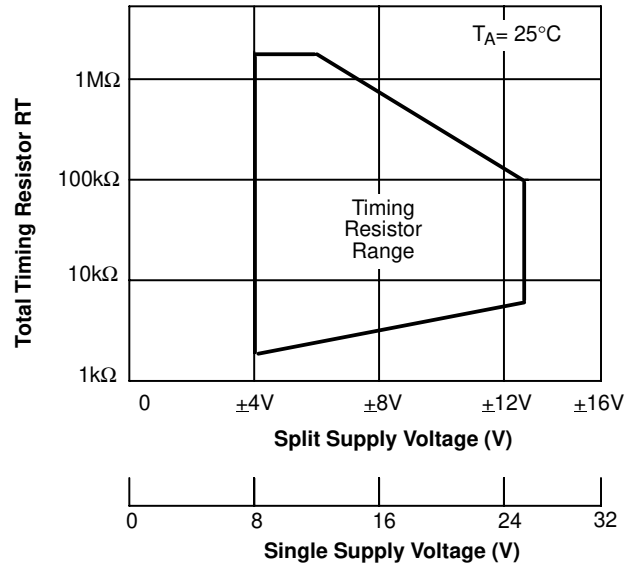


**Figure 6. Positive Supply Current, I+ (Measured at Pin 1) vs. Supply Voltage**

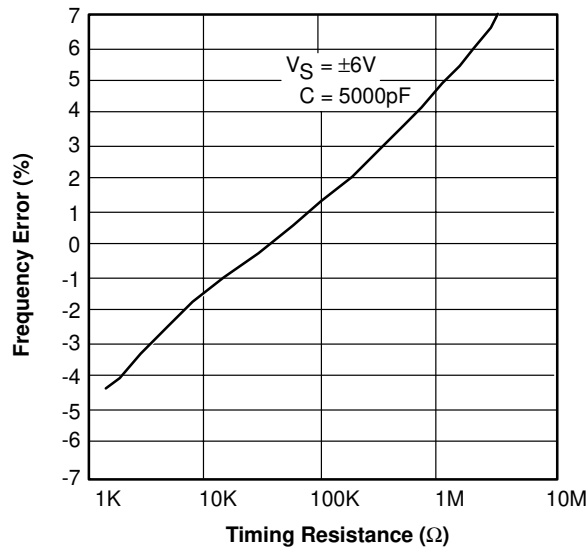




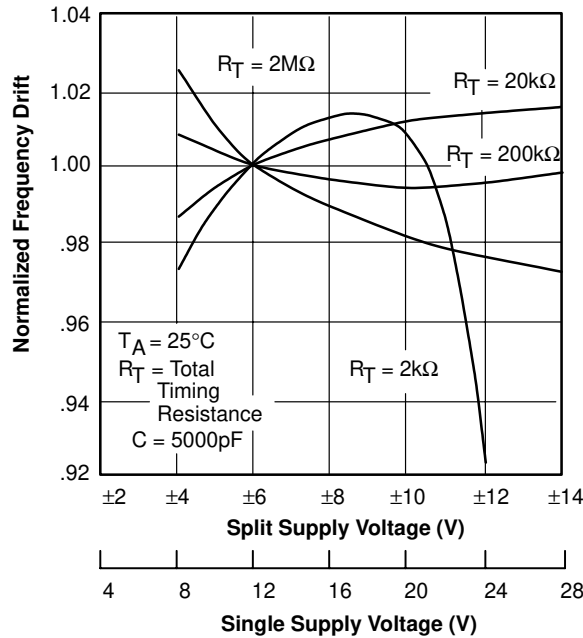
**Figure 7. Negative Supply Current, I<sub>-</sub> (Measured at Pin 6) vs. Supply Voltage**



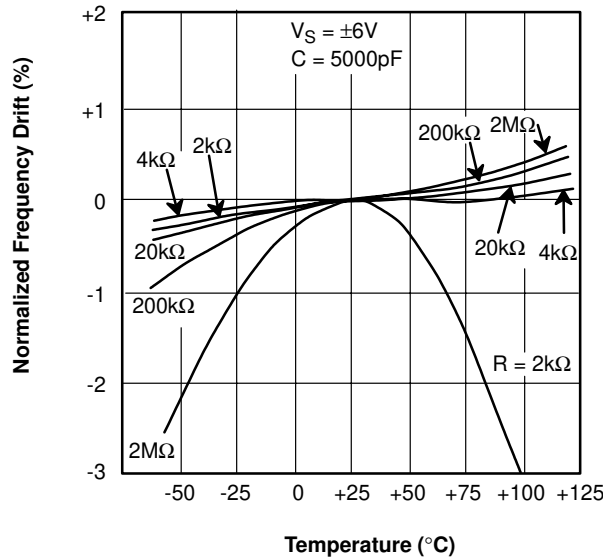
**Figure 8. Recommended Timing Resistor Value vs. Power Supply Voltage**



**Figure 9. Frequency Accuracy vs. Timing Resistance**



**Figure 10. Frequency Drift vs. Supply Voltage**



**Figure 11. Normalized Frequency Drift with Temperature**

**Squarewave Output (Pin 7)**

The squarewave output at pin 7 is an “open-collector” stage capable of sinking up to 20mA of load current.  $R_L$  serves as a pull-up load resistor for this output. Recommended values for  $R_L$  range from 1k $\Omega$  to 100k $\Omega$ .

**Triangle Output (Pin 8)**

The output at pin 8 is a triangle wave with a peak swing of approximately one-half of the total supply voltage. Pin 8 has a 10 $\Omega$  output impedance and is internally protected against short circuits.

## MODES OF OPERATION

### Split Supply Operation

Figure 12 is the recommended configuration for split supply operation. Diode  $D_1$  in the figure assures that the triangle output swing at pin 8 is symmetrical about ground. The circuit operates with supply voltages ranging from  $\pm 4V$  to  $\pm 13V$ . Minimum drift occurs with  $\pm 6V$  supplies. For operation with unequal supply voltages, see Figure 5.

With the generalized circuit of Figure 12, the frequency of

operation is determined by the timing capacitor,  $C$ , and the timing resistor.

The squarewave output is obtained at pin 7 and has a peak-to-peak voltage swing equal to the supply voltages. This output is an “open-collector” type and requires an external pull-up load resistor (nominally  $5k\Omega$ ) to the positive supply. The triangle waveform obtained at pin 8 is centered about ground and has a peak amplitude of  $V_{CC}/2$ .

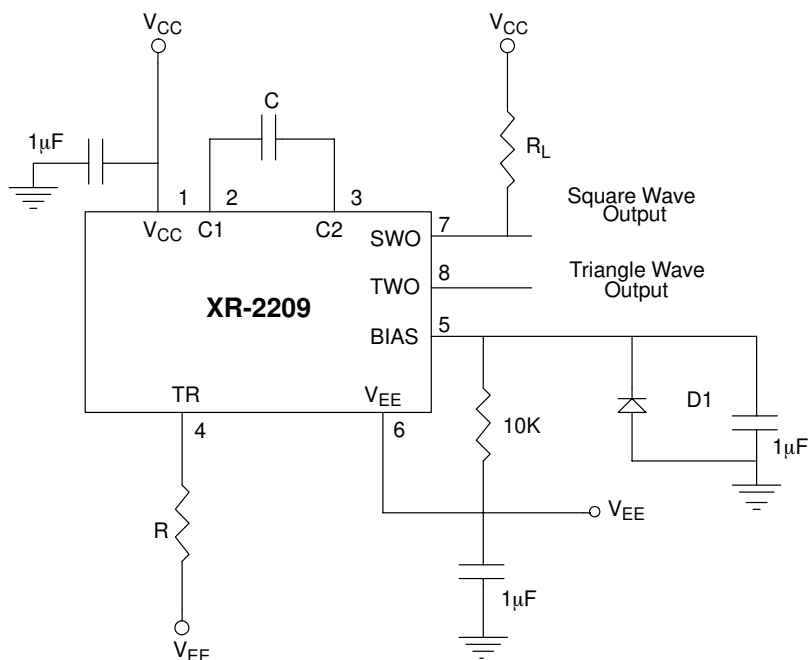
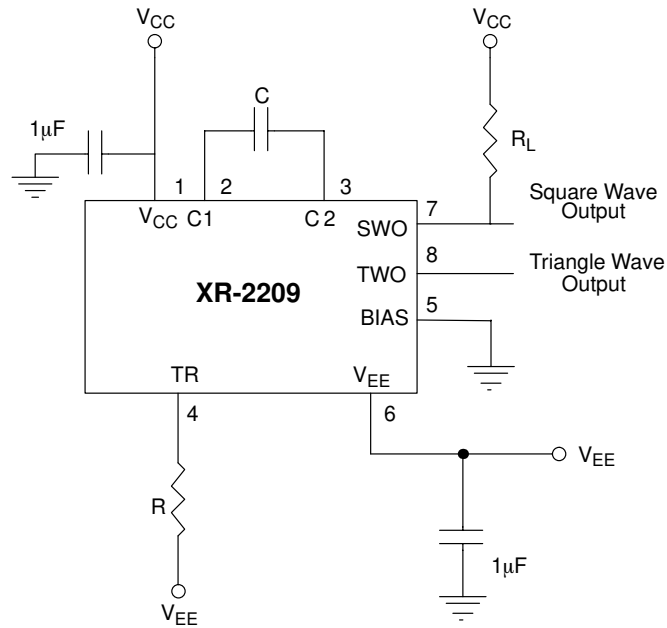


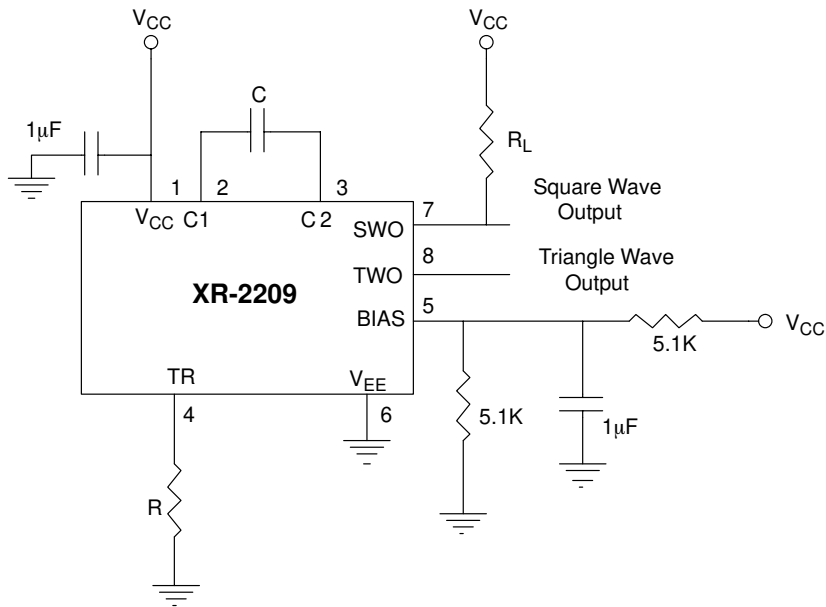
Figure 12. Split-Supply Operation, Recommended Configuration

Figure 13 is a simplified configuration for operation with split supplies in excess of  $\pm 7V$ . This circuit eliminates the diode D1 used in Figure 12 by grounding pin 5 directly;

however, the triangle wave output now has a +0.6V DC offset with respect to ground.



**Figure 13. Split-Supply Operation, Simplified Configuration**



**Figure 14. Single Supply Operation**

### Single Supply Operation

The circuit should be interconnected as shown in *Figure 14* for single supply operation. Pin 6 should be grounded, and pin 5 biased from  $V_{CC}$  through a resistive divider to a value of bias voltage between  $V_{CC}/3$  and  $V_{CC}/2$ .

The frequency of operation is determined by the timing capacitor  $C$  and the timing resistor  $R$ , and is equal to  $1/RC$ . The squarewave output is obtained at pin 7 and has a peak-to-peak voltage swing equal to the supply voltage. This output is an “open-collector” type and requires an external pull-up load resistor (nominally  $5k\Omega$ ) to  $V_+$ . The triangle waveform obtained at pin 8 is centered about a voltage level  $V_O$  where:

$$V_O = V_B + 0.6V$$

where  $V_B$  is the bias voltage at pin 5. The peak-to-peak output swing of triangle wave is approximately equal to  $V_{CC}/2$ .

### Frequency Control (Sweep and FM) - Split Supply

The circuit given in *Figure 15* shows a frequency sweep method for split supply operation.

The frequency of operation is controlled by varying the total timing current,  $I_T$ , drawn from the activated timing pin 4. The timing current can be modulated by applying a control voltage,  $V_C$ , to the timing pin through a series resistor  $R$ . As the control voltage becomes more negative, both the total timing current,  $I_T$ , and the oscillation frequency increase.

The frequency of operation, is now proportional to the control voltage,  $V_C$ , and determined as:

$$f = \frac{1}{RC} \left[ 1 + \frac{V_C R}{R_C V_{EE}} \right] \text{ Hz}$$

If  $R = 2M\Omega$ ,  $R_C = 2k\Omega$ ,  $C = 5000pF$ , then a 1000:1 frequency sweep would result for a negative sweep voltage  $V_C \approx V_{EE}$ .

The voltage to frequency conversion gain,  $K$ , is controlled by the series resistance  $R_C$  and can be expressed as:

$$K = \frac{\Delta f}{\Delta V_C} = -\frac{1}{R_C C V_{EE}} \text{ Hz/V}$$

The circuit of *Figure 15* can operate both with positive and negative values of control voltage. However, for positive values of  $V_C$  with small ( $R_C/R$ ) ratio, the direction of the timing current  $I_T$  is reversed and the oscillations will stop.

**Frequency Control (Sweep and FM) - Single Supply**

The circuit given in *Figure 16* shows the frequency sweep method for single supply operation. Here, the oscillation

frequency is given as:

$$f = \frac{1}{RC} \left[ 1 + \frac{R}{R_C} \left( 1 - \frac{V_C}{V_T} \right) \right]$$

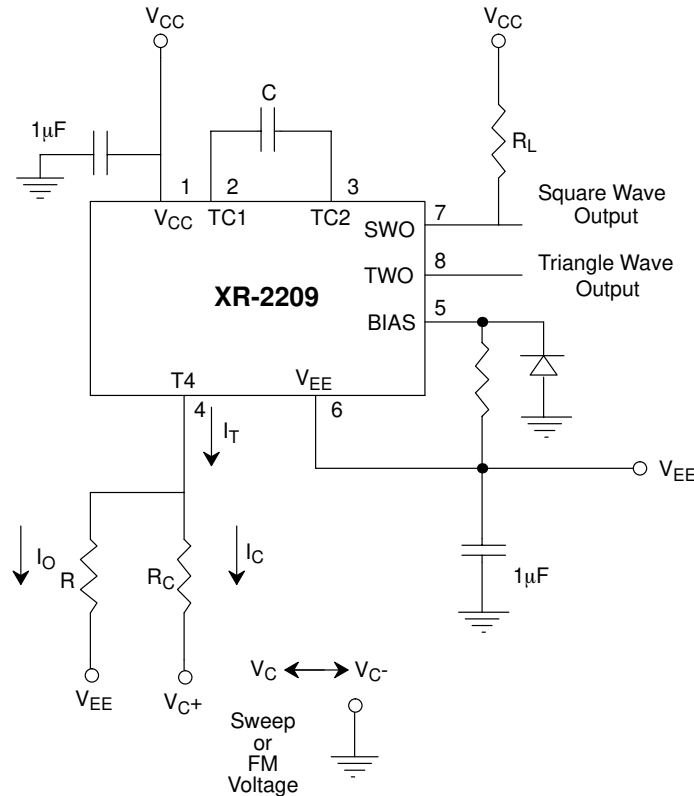
where  $V_T = V_{pin4} \sim V_{bias} + 0.7V$ .

This equation is valid from  $V_C = 0V$  where  $R_C$  is in parallel with  $R$  and  $I_T$  is maximum to:

$$V_C = V_T \left( 1 + \frac{R_C}{R} \right)$$

where  $I_T = 0$  and oscillation ceases.

**Caution:** Total timing current  $I_T$  must be less than 6mA over the frequency control range.



**Figure 15. Frequency Sweep Operation, Split Supply**

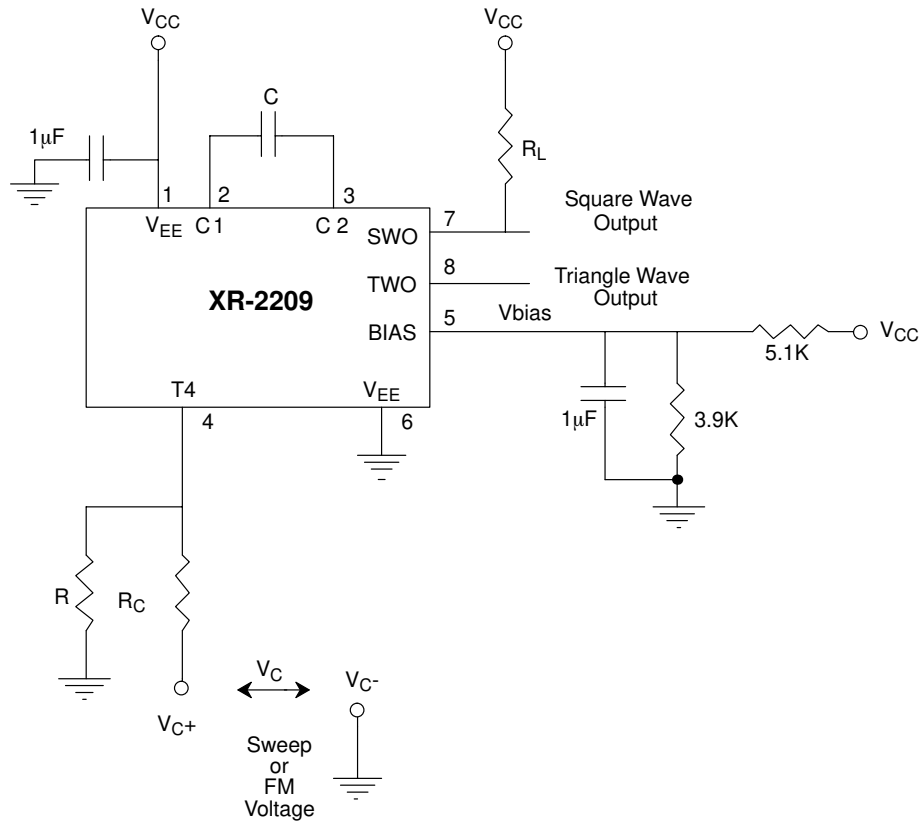
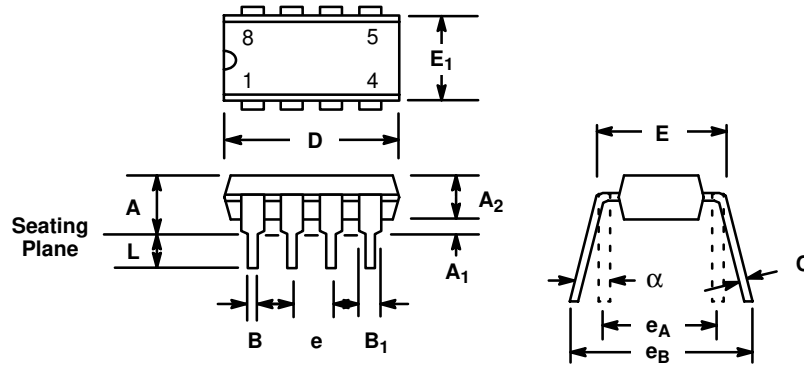


Figure 16. Frequency Sweep Operation, Single Supply

**8 LEAD PLASTIC DUAL-IN-LINE  
(300 MIL PDIP)**

*Rev. 1.00*



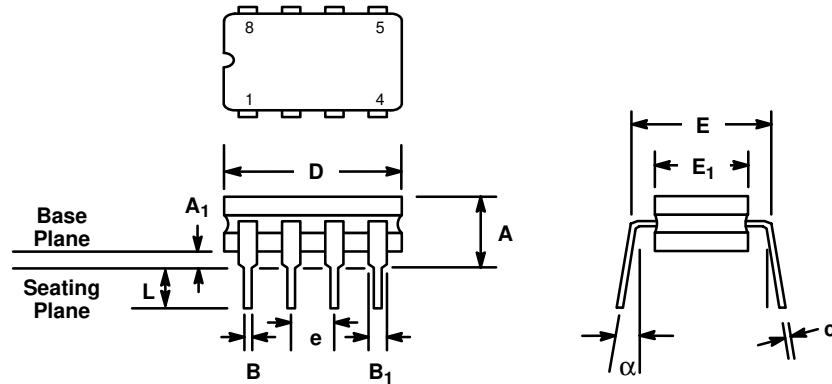
SYMBOL	INCHES		MILLIMETERS	
	MIN	MAX	MIN	MAX
A	0.145	0.210	3.68	5.33
A <sub>1</sub>	0.015	0.070	0.38	1.78
A <sub>2</sub>	0.015	0.195	2.92	4.95
B	0.014	0.024	0.36	0.56
B <sub>1</sub>	0.030	0.070	0.76	1.78
C	0.008	0.014	0.20	0.38
D	0.348	0.430	8.84	10.92
E	0.300	0.325	7.62	8.26
E <sub>1</sub>	0.240	0.280	6.10	7.11
e	0.100 BSC		2.54 BSC	
e <sub>A</sub>	0.300 BSC		7.62 BSC	
e <sub>B</sub>	0.310	0.430	7.87	10.92
L	0.115	0.160	2.92	4.06
α	0°	15°	0°	15°

*Note: The control dimension is the inch column*



## 8 LEAD CERAMIC DUAL-IN-LINE (300 MIL CDIP)

Rev. 1.00



SYMBOL	INCHES		MILLIMETERS	
	MIN	MAX	MIN	MAX
A	0.100	0.200	2.54	5.08
A <sub>1</sub>	0.015	0.060	0.38	1.52
B	0.014	0.026	0.36	0.66
B <sub>1</sub>	0.045	0.065	1.14	1.65
c	0.008	0.018	0.20	0.46
D	0.305	0.405	7.75	10.29
E <sub>1</sub>	0.250	0.310	6.35	7.87
E	0.300 BSC		7.62 BSC	
e	0.100 BSC		2.54 BSC	
L	0.125	0.200	3.18	5.08
α	0°	15°	0°	15°

Note: The control dimension is the inch column

**Notes**

**Notes**

# Notes

## NOTICE

EXAR Corporation reserves the right to make changes to the products contained in this publication in order to improve design, performance or reliability. EXAR Corporation assumes no responsibility for the use of any circuits described herein, conveys no license under any patent or other right, and makes no representation that the circuits are free of patent infringement. Charts and schedules contained herein are only for illustration purposes and may vary depending upon a user's specific application. While the information in this publication has been carefully checked; no responsibility, however, is assumed for inaccuracies.

EXAR Corporation does not recommend the use of any of its products in life support applications where the failure or malfunction of the product can reasonably be expected to cause failure of the life support system or to significantly affect its safety or effectiveness. Products are not authorized for use in such applications unless EXAR Corporation receives, in writing, assurances to its satisfaction that: (a) the risk of injury or damage has been minimized; (b) the user assumes all such risks; (c) potential liability of EXAR Corporation is adequately protected under the circumstances.

Copyright 1975 EXAR Corporation  
Datasheet June 1997

Reproduction, in part or whole, without the prior written consent of EXAR Corporation is prohibited.