



Chipsmall Limited consists of a professional team with an average of over 10 year of expertise in the distribution of electronic components. Based in Hongkong, we have already established firm and mutual-benefit business relationships with customers from,Europe,America and south Asia,supplying obsolete and hard-to-find components to meet their specific needs.

With the principle of “Quality Parts,Customers Priority,Honest Operation,and Considerate Service”,our business mainly focus on the distribution of electronic components. Line cards we deal with include Microchip,ALPS,ROHM,Xilinx,Pulse,ON,Everlight and Freescale. Main products comprise IC,Modules,Potentiometer,IC Socket,Relay,Connector.Our parts cover such applications as commercial,industrial, and automotives areas.

We are looking forward to setting up business relationship with you and hope to provide you with the best service and solution. Let us make a better world for our industry!



## Contact us

Tel: +86-755-8981 8866 Fax: +86-755-8427 6832

Email & Skype: info@chipsmall.com Web: www.chipsmall.com

Address: A1208, Overseas Decoration Building, #122 Zhenhua RD., Futian, Shenzhen, China





### Description

The XR33180, XR33181, XR33183 and XR33184 are high performance RS-485/RS-422 receivers designed to meet the increasing system requirements found in today's high performance serial communication applications.

The receiver includes enhanced failsafe circuitry, guaranteeing a logic-high receiver output when the receiver inputs are open, shorted, or undriven. The XR33180/81/83/84 (XR3318x) receiver input impedance is at least  $48\text{k}\Omega$  (1/4 unit load), allowing more than 128 devices on the bus. The bus pins are ESD protected and pass IEC61000 level 4 ( $\pm 15\text{kV}$ ).

This is a wide supply (3.0V to 5.5V) device that operates at a maximum data rate of 52Mbps and comes in very small 5-pin and 6-pin TSOT23 packages, making this standalone receiver ideal for high speed point-to-point RS-485 applications where space is a concern.

The XR3318x offers several pinout options to maximize performance in different applications while maintaining a minimum pin count. The XR33180 is available in a 5-pin TSOT23 package with the receiver always enabled. The XR33181 is available in a 6-pin TSOT23 package and offers a active high receiver enable pin while the XR33183 has the same pinout but with active low enable pin. The XR33184 is available in a 6-pin TSOT23 package with a I/O logic supply pin to ease the interface to MCU's or FPGA's that run off of different supply voltages. The  $V_L$  supply pin allows the XR33184 to interface to other devices running off of supplies from ranging from 1.65V to  $V_{CC}$ .

All XR3318x options operate up to a max data rate of 52Mbps, and have excellent propagation delay and skew characteristics making them a good choice for clock fanout or clock distribution systems.

### Typical Application

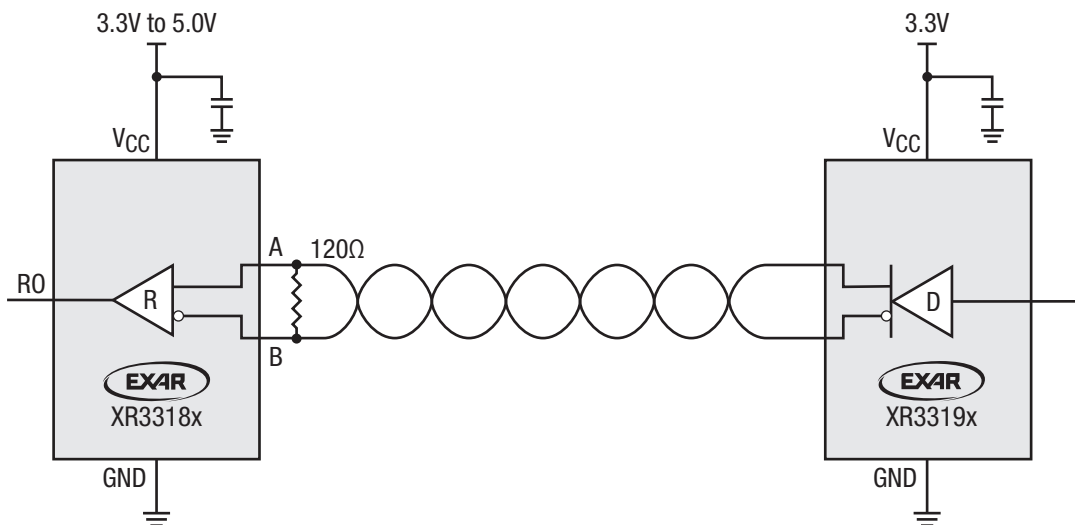

Figure 1. Typical Application

### FEATURES

- Max 52Mbps data rate
- Wide 3.0V to 5.5V supply operation
- Robust Electrostatic Discharge (ESD) protection for RS-485 bus pins
  - $\pm 15\text{kV}$  human body model
  - $\pm 15\text{kV}$  IEC61000-4-2 air discharge
  - $\pm 8\text{kV}$  IEC61000-4-2 contact discharge
- Enhanced receiver failsafe protection for open, shorted, or terminated but idle data lines
- $-40^\circ\text{C}$  to  $125^\circ\text{C}$  ambient operating temperature range
- Lead-free (RoHS 6) TSOT23-5 and TSOT23-6 packaging
- Absolute minimum pin count option, XR33180 (5-pin TSOT23)
- Tri-state RO options, XR33181 and XR33183
- Adjustable I/O supply option to help interfacing to lower voltage logic, XR33184

### APPLICATIONS

- Clock distribution
- Robotic control
- Space constrained systems
- Security camera networks
- Industrial and process control equipment

## Absolute Maximum Ratings

Stresses beyond those listed under Absolute Maximum Ratings may cause permanent damage to the device. Exposure to any Maximum Rating condition for extended periods may affect device reliability and lifetime.

Supply voltage ( $V_{CC}$ ) ..... -0.3V to 7.0V

Junction temperature ..... 150°C

### Input Voltages

EN and  $\overline{EN}$  ..... -0.3V to 7.0V

### Output Voltage

RO (XR33180/81/83) ..... -0.3V to ( $V_{CC} + 0.3V$ )

RO (XR33184) ..... -0.3V to ( $V_L + 0.3V$ )

### Receiver Input Voltages

A, B .....  $\pm 18V$

Transient voltage pulse, through 100 $\Omega$  <sup>(1)</sup> .....  $\pm 100V$

#### NOTE:

1. Refer to Figure 3.

## Operating Conditions

Operating temperature range ..... -40°C to 125°C

$V_{CC}$  supply range ..... 3.0V to 5.5V

### Thermal Information

5-pin TSOT23  $\theta_{JA}$  ..... 185.5°C/W

5-pin TSOT23  $\theta_{JC}$  ..... 61.6°C/W

6-pin TSOT23  $\theta_{JA}$  ..... 167.3°C/W

6-pin TSOT23  $\theta_{JC}$  ..... 61.6°C/W

## Electrical Characteristics

Specifications are at  $T_A = 25^\circ C$ ,  $V_{CC} = 3.0V$  to 5.5V unless otherwise noted. Typical values represent the most likely parametric norm at  $T_A = 25^\circ C$ , and are provided for reference purposes only.

Symbol	Parameter	Conditions	Min	Typ	Max	Units
Supply						
$V_{CC}$	Supply voltage range		3.0		5.5	V
$V_L$	I/O supply voltage range	$V_L \leq V_{CC}$	1.65		$V_{CC}$	V
$I_{CC}$	Supply current	No Load, XR33180/81/83/84		2.5	5	mA
$I_L$	I/O supply	No Load, XR33184			10	$\mu A$
Receiver DC Characteristics						
$V_{TH}$	Receiver differential threshold voltage, $V_A - V_B$	$-7V \leq V_{CM} \leq 12V$	-200	-125	-50	mV
$\Delta V_{OH}$	Receiver input hysteresis	$V_{CM} = 0V$		25		mV
$R_{IN}$	Receiver input resistance	$-7V \leq V_{CM} \leq 12V$	48			k $\Omega$
$I_{A,B}$	Input current, A and B	$V_{OUT} = 12V, V_{CC} = 0V$ or 5.5V			250	$\mu A$
		$V_{OUT} = -7V, V_{CC} = 0V$ or 5.5V	-200			$\mu A$

## Electrical Characteristics

Specifications are at  $T_A = 25^\circ\text{C}$ ,  $V_{CC} = 3.0\text{V}$  to  $5.5\text{V}$  unless otherwise noted. Typical values represent the most likely parametric norm at  $T_A = 25^\circ\text{C}$ , and are provided for reference purposes only.

Symbol	Parameter	Conditions	Min	Typ	Max	Units
Logic Inputs/Outputs						
$V_{IH}$	Logic high input thresholds, EN and $\overline{EN}$	XR33181/83	2			V
$V_{IL}$	Logic low input thresholds, EN and $\overline{EN}$	XR33181/83			0.4	V
$I_{ENLEAK}$	Enable pin leakage	XR33181/83	-10		10	$\mu\text{A}$
$V_{OH}$	Receiver output high voltage, RO	$I_{OUT} = -4\text{mA}$ , XR33180/81/83	$V_{CC} - 0.4$			V
$V_{OL}$	Receiver output low voltage, RO	$I_{OUT} = 4\text{mA}$ , XR33180/81/83			0.4	V
$V_{OH}$	Receiver output high voltage, RO	$3.0\text{V} \leq V_L \leq 5.5\text{V}$ , $I_{OUT} = -4\text{mA}$ $1.65\text{V} \leq V_L \leq 3.0\text{V}$ , $I_{OUT} = -1\text{mA}$ , XR33184	$V_L - 0.4$			V
$V_{OL}$	Receiver output low voltage, RO	$3.0\text{V} \leq V_L \leq 5.5\text{V}$ , $I_{OUT} = 4\text{mA}$ $1.65\text{V} \leq V_L \leq 3.0\text{V}$ , $I_{OUT} = 1\text{mA}$ , XR33184			0.4	V
$I_{OSC}$	Receiver output short-circuit current	$0\text{V} \leq V_{RO} \leq V_L$	-120		120	mA
$I_{OZR}$	High-Z receiver output current	$0\text{V} \leq V_{OUT} \leq V_{CC}$ , XR33180/81/83 $0\text{V} \leq V_{OUT} \leq V_L$ , XR33184	-1		1	$\mu\text{A}$
Thermal Characteristics						
$T_{TS}$	Thermal shutdown temperature			168		$^\circ\text{C}$
$T_{TSH}$	Thermal shutdown hysteresis			15		$^\circ\text{C}$
ESD Protection						
		Human Body Model (HBM)		$\pm 15$		kV
	ESD protection for RS-485 bus pins, A and B	IEC 61000-4-2 air gap		$\pm 15$		kV
		IEC 61000-4-2 contact		$\pm 8$		kV
	ESD Protection for all other pins	Human Body Model (HBM)		$\pm 4$		kV
Receiver AC Characteristics						
$t_{RPLH}$	Receiver propagation delay, low to high	$C_L = 15\text{pF}$ , $V_{ID} = \pm 2\text{V}$ , $V_{ID}$ rise and fall times $< 15\text{ns}$ , Figure 4			15	ns
$t_{RPHL}$	Receiver propagation delay, high to low				15	ns
$ t_{RPLH} - t_{RPHL} $	Receiver propagation delay skew				2	ns
	Propagation delay matching, device to device <sup>(1)</sup>	Part to part comparisons must have the same supply conditions and temperature difference $\leq 30^\circ\text{C}$ (max)			8	ns
	Maximum data rate <sup>(1)</sup>	$C_L = 15\text{pF}$ , Duty Cycle 40 to 60%	52			Mbps
$t_{RZH}$	Receiver enable to output high	$C_L = 15\text{pF}$ , $R_L = 1\text{K}\Omega$ , Figure 5			500	ns
$t_{RZL}$	Receiver enable to output low				500	ns
$t_{RHZ}$	Receiver disable from output high				500	ns
$t_{RLZ}$	Receiver disable from output low				500	ns

**NOTE:**

1. Guaranteed by design.

## Pin Configuration

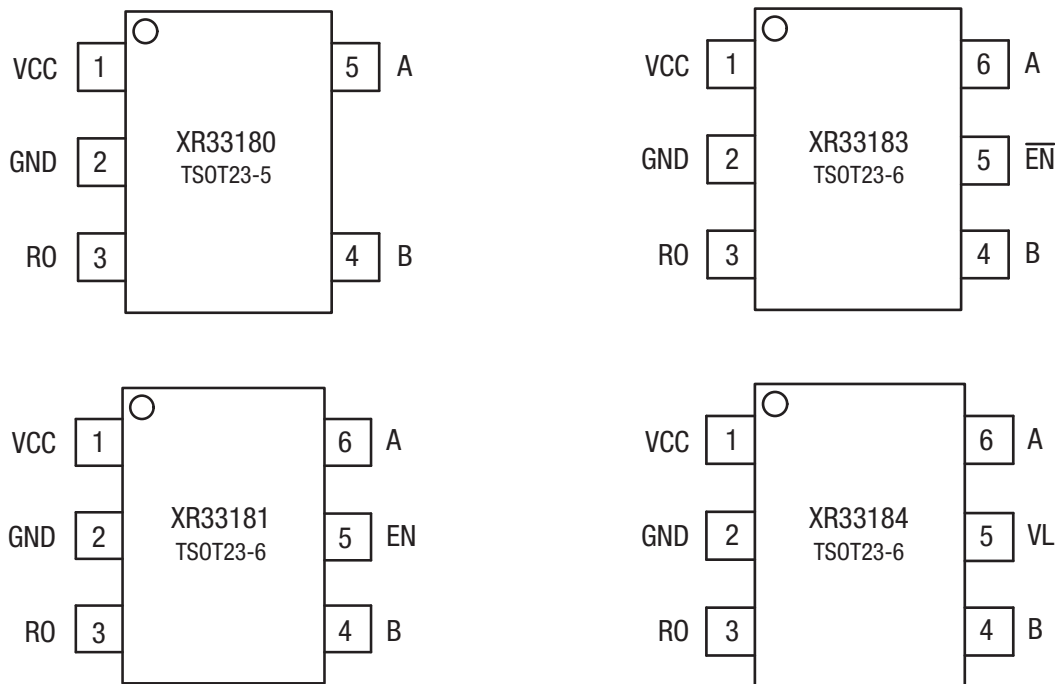

## Pin Functions

Pin Number				Pin Name	Type	Description
XR33180	XR33181	XR33183	XR33184			
1	1	1	1	VCC	Supply	Power supply, bypass with 0.1 $\mu$ f capacitor
2	2	2	2	GND	Supply	Ground
3	3	3	3	RO	Output	Receiver output: if $(V_A - V_B) \geq -50\text{mV}$ , RO is high if $(V_A - V_B) \leq -200\text{mV}$ , RO is low
4	4	4	4	B	Bus Input	$\pm 15\text{KV}$ ESD protected, RS-485/RS-422 inverting receiver input
-	5	-	-	EN	Input	Receiver output enable: when EN is low, RO is disabled, high impedance when EN is high, RO is enabled
-	-	5	-	$\overline{\text{EN}}$	Input	Receiver output enable: when $\overline{\text{EN}}$ is high, RO is disabled, high impedance when $\overline{\text{EN}}$ is low, RO is enabled
-	-	-	5	VL	Supply	Logic interface power supply
5	6	6	6	A	Bus Input	$\pm 15\text{KV}$ ESD protected, RS-485/RS-422 non-inverting receiver input

**Pin Functions (Continued)**

Receiving		
Inputs		Output
$\overline{RE}$	$V_A - V_B$	RO
0	$\geq -50\text{mV}$	1
0	$\leq -200\text{mV}$	0
0	Open/shorted/idle	1
1	X	High-Z

Functional Block Diagrams

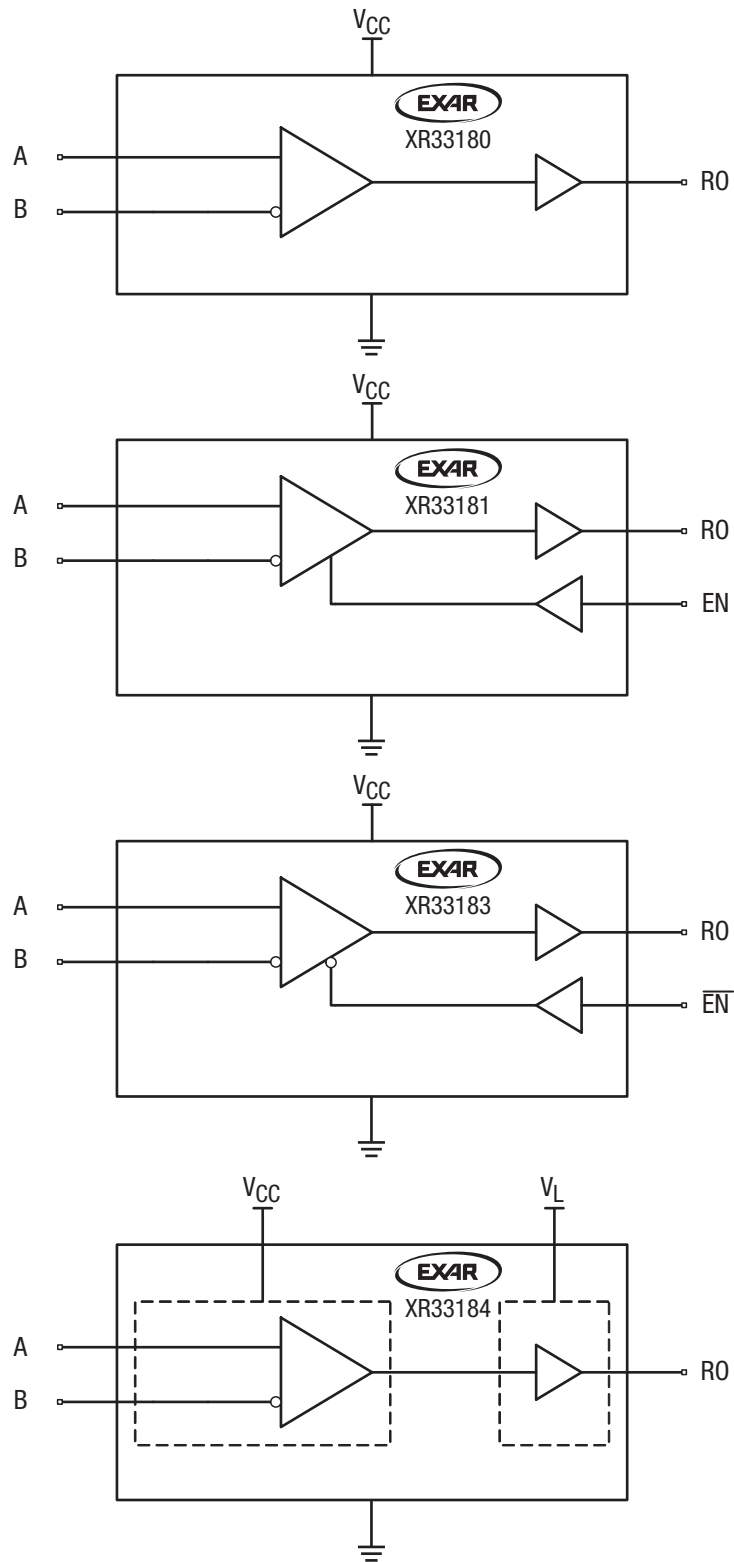

Figure 2. Functional Block Diagrams

Applications Information

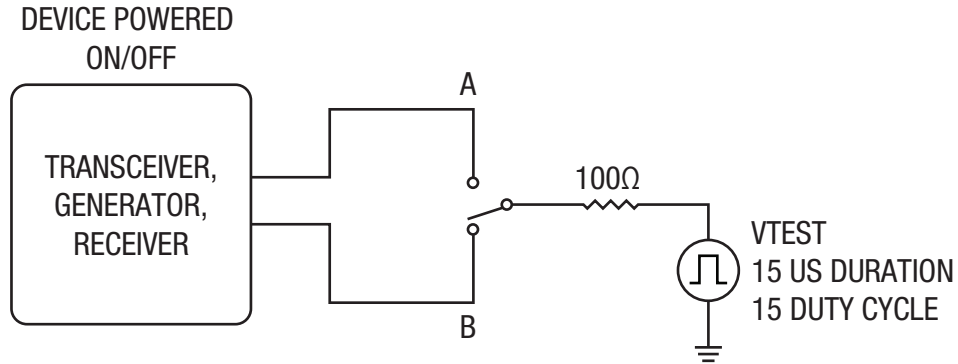

Figure 3. Transient Overvoltage Test Circuit

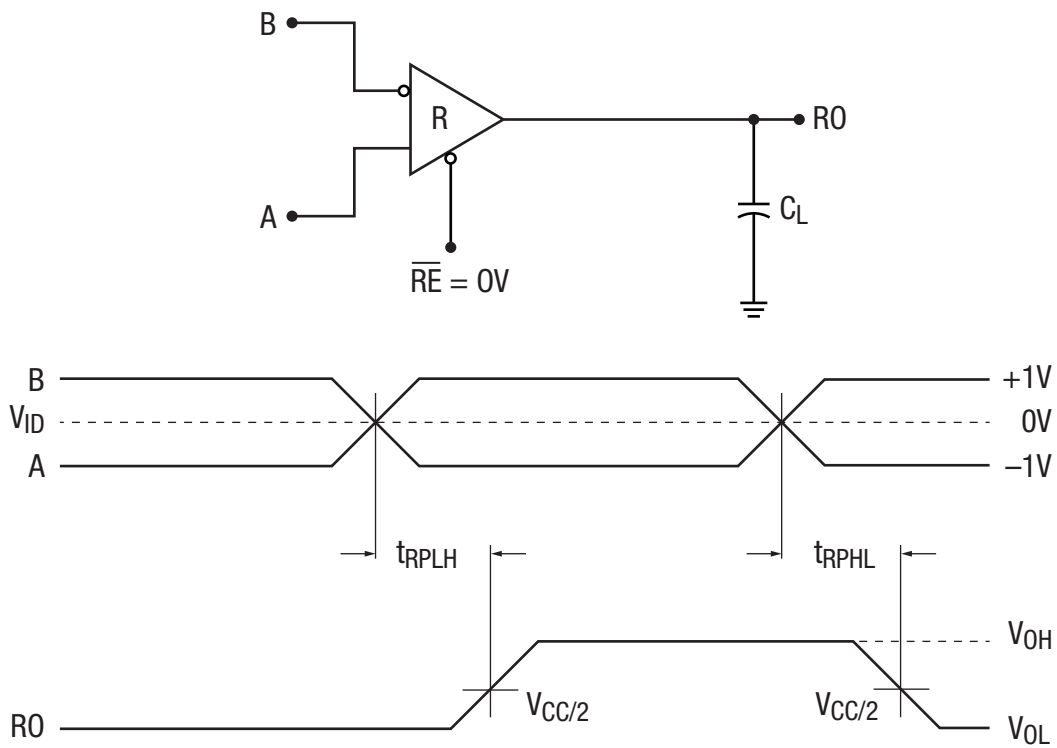

Figure 4. Receiver Propagation Delay Test Circuit and Timing Diagram



Applications Information (Continued)

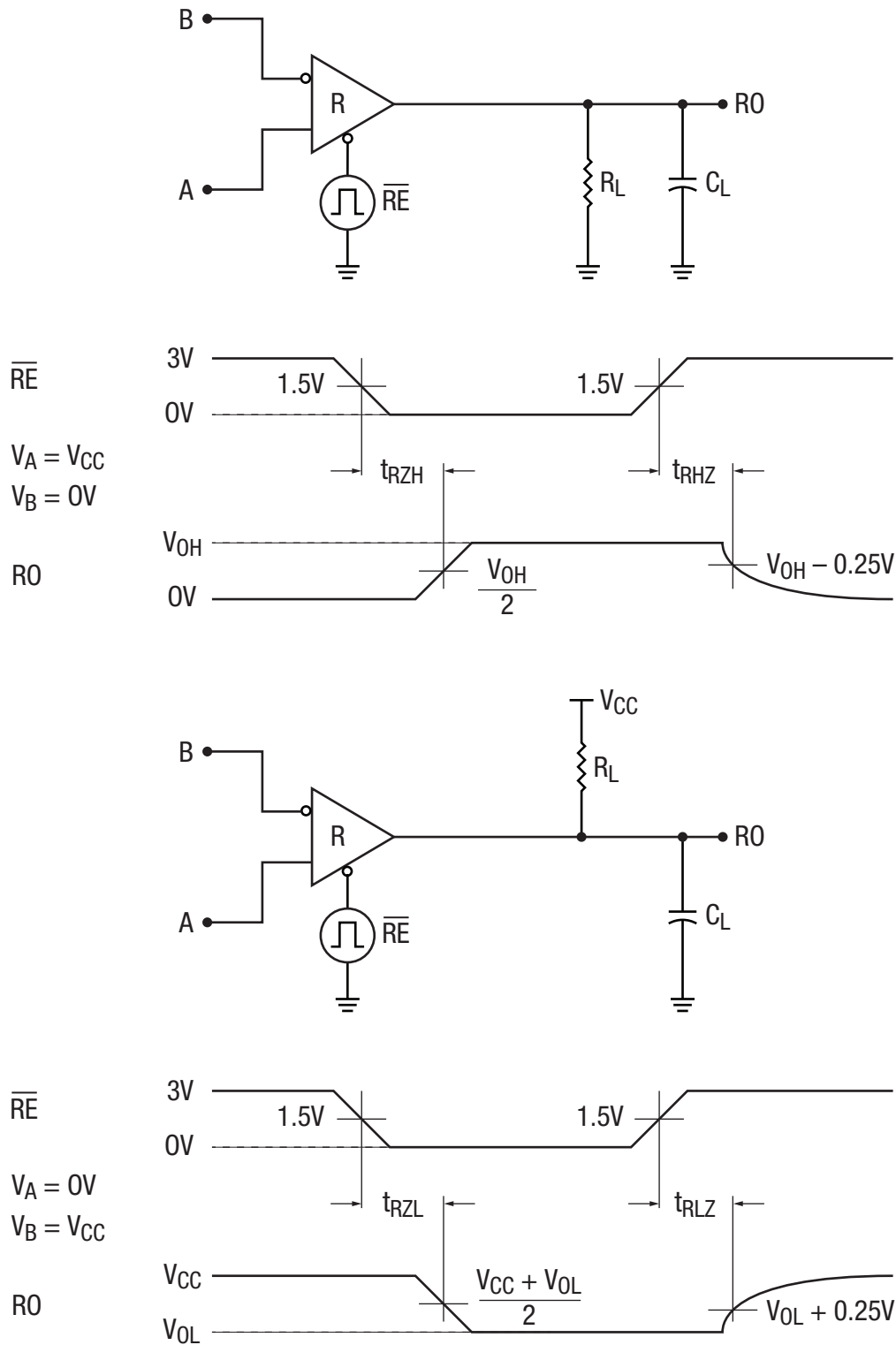

Figure 5. Receiver Enable and Disable Test Circuits and Timing Diagrams

## Applications Information (Continued)

The XR3318x RS-485/RS-422 device is part of Exar's high performance serial interface product line. The analog bus pins can survive direct shorts up to  $\pm 18V$  and are protected against ESD events up to  $\pm 15kV$ .

### Enhanced Failsafe

Ordinary RS-485 differential receivers will be in an indeterminate state whenever the data bus is not being actively driven. The enhanced failsafe feature of the XR3318x guarantees a logic-high receiver output when the receiver inputs are open, shorted or when they are connected to a terminated transmission line with all drivers disabled. In a terminated bus with all transmitters disabled, the receivers' differential input voltage is pulled to 0V by the termination. The XR3318x interprets 0V differential as a logic high with a minimum 50mV noise margin while maintaining compliance with the RS-485 standard of  $\pm 200mV$ . Although the XR3318x does not need failsafe biasing resistors, it can operate without issue if biasing is used.

### $\pm 15kV$ ESD Protection

ESD protection structures are incorporated on all pins to protect against electrostatic discharges encountered during handling and assembly. The receiver inputs of the XR3318x have extra protection against static electricity. Exar uses state-of-the-art structures to protect these pins against ESD of  $\pm 15kV$  without damage. The ESD structures withstand high ESD in all states: normal operation and powered down. After an ESD event, the XR3318x keeps operating without latch-up or damage.

ESD protection can be tested in various ways. The receiver inputs of the XR3318x are characterized for protection to the following limits:

- $\pm 15kV$  HBM (Human Body Model), bus pins
- $\pm 15kV$  IEC 61000-4-2 air discharge, bus pins
- $\pm 8kV$  IEC 61000-4-2 contact discharge, bus pins
- $\pm 4kV$  using the Human Body Model, all other pins

### ESD Test Conditions

ESD performance depends on a variety of conditions. Contact Exar for a reliability report that documents test setup, methodology and results.

### Maximum Number of Receivers on the Bus

The standard RS-485 receiver input impedance is  $12k\Omega$  (1 unit load). A standard driver can drive up to 32 unit loads. The XR3318x receiver has a 1/4th unit load receiver input impedance of  $48K\Omega$ , allowing up to 128 receivers to be connected in parallel on a communication line. Any combination of the XR33180/81/83/84's and other RS-485 receivers up to a total of 32 unit loads may be connected to the line.

### Product Selector Guide

Part Number	Data Rate	Receiver Enable	Nodes On Bus	$V_L$ Pin	Package
XR33180	52Mbps	No	128	No	5-pin TSOT23
XR33181		Yes (active high)		No	6-pin TSOT23
XR33183		Yes (active low)		No	
XR33184		No		Yes	

Package Description

5-Pin TSOT23

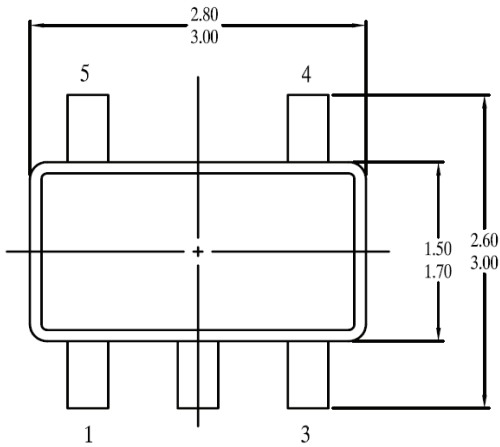

TOP VIEW

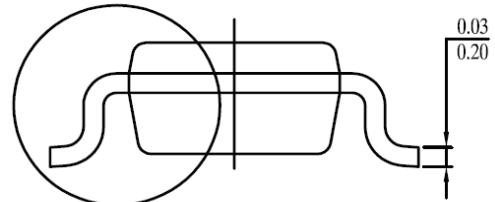

SEE DETAIL "A"

SIDE VIEW-1

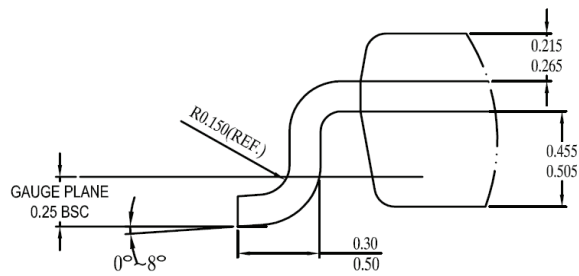

DETAIL "A"

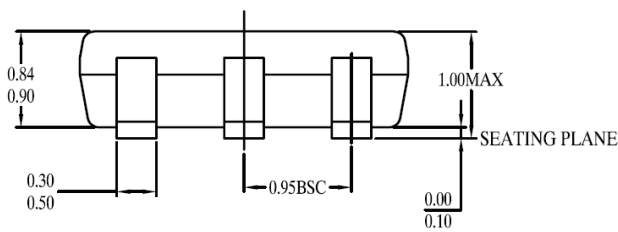

SIDE VIEW - 2

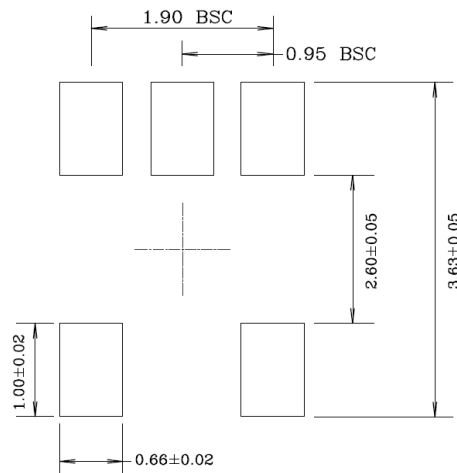

TYPICAL RECOMMENDED LAND PATTERN

1. All dimensions are in Millimeters
2. Dimensions and tolerance per Jecdec MO-193

Package Description (Continued)

6-Pin TSOT23

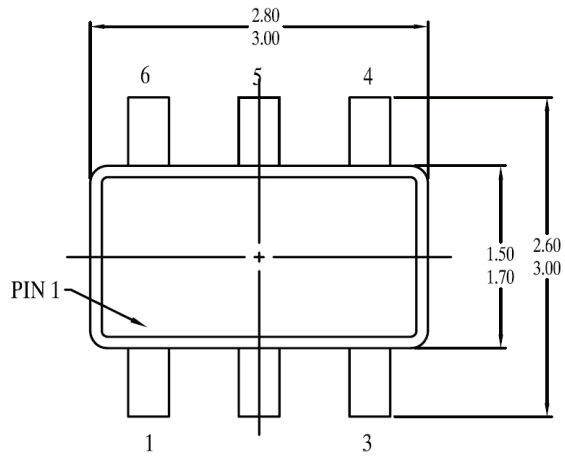

TOP VIEW

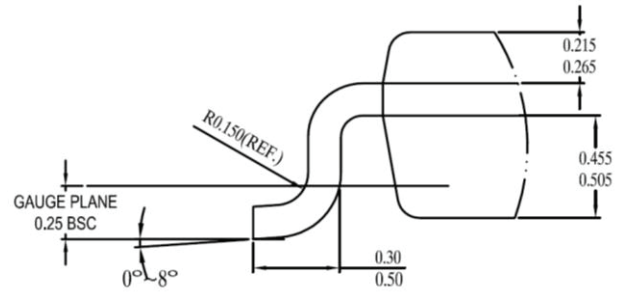

DETAIL "A"

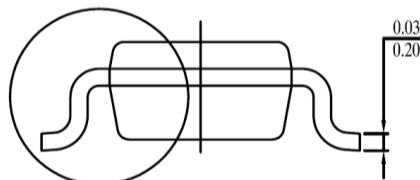

SEE DETAIL "A"

SIDE VIEW-1

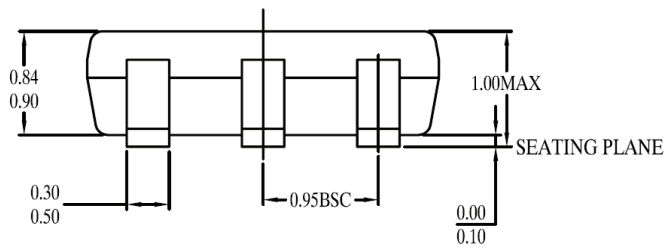

SIDE VIEW - 2

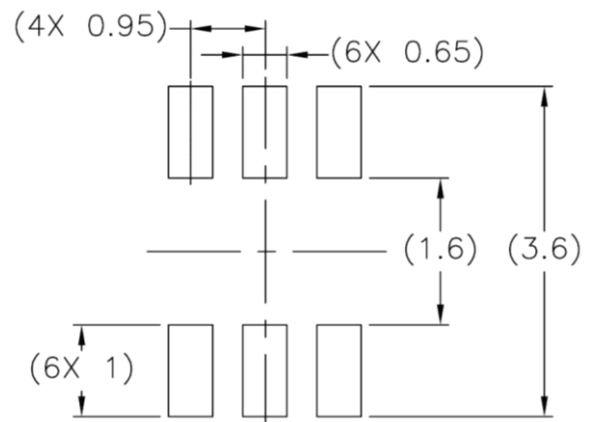

TYPICAL RECOMMENDED LAND PATTERN

1. All dimensions are in Millimeters
2. Dimensions and tolerance per Jedec MO-193

## Ordering Information

Part Number	Additional Feature	Operating Temperature Range	Environmental Rating	Package	Packaging Quantity
XR33180ESBTR	-	-40°C to 125°C	RoHS Compliant & Green <sup>(1)</sup>	5-pin TSOT23	3k tape and reel
XR33181ESBTR	Active High Enable			6-pin TSOT23	
XR33183ESBTR	Active Low Enable				
XR33184ESBTR	Logic Level Supply, V <sub>L</sub>				
XR33180ESBEVB	Evaluation Board				
XR33181ESBEVB					
XR33183ESBEVB					
XR33184ESBEVB					

**NOTE:**

1. Visit [www.exar.com](http://www.exar.com) for more information.

## Revision History

Revision	Date	Description
1A	June 2016	Initial Release
1B	August 2016	Update tape and reel quantity in Ordering Information table



[www.exar.com](http://www.exar.com)

48760 Kato Road  
Fremont, CA 94538  
USA

Tel.: +1 (510) 668-7000  
Fax: +1 (510) 668-7001  
Email: [serialtechsupport@exar.com](mailto:serialtechsupport@exar.com)

Exar Corporation reserves the right to make changes to the products contained in this publication in order to improve design, performance or reliability. Exar Corporation conveys no license under any patent or other right and makes no representation that the circuits are free of patent infringement. While the information in this publication has been carefully checked, no responsibility, however, is assumed for inaccuracies.

Exar Corporation does not recommend the use of any of its products in life support applications where the failure or malfunction of the product can reasonably be expected to cause failure of the life support system or to significantly affect its safety or effectiveness. Products are not authorized for use in such applications unless Exar Corporation receives, in writing, assurances to its satisfaction that: (a) the risk of injury or damage has been minimized; (b) the user assumes all such risks; (c) potential liability of Exar Corporation is adequately protected under the circumstances.

Reproduction, in part or whole, without the prior written consent of Exar Corporation is prohibited. Exar, XR and the XR logo are registered trademarks of Exar Corporation. All other trademarks are the property of their respective owners.

©2016 Exar Corporation