



Chipsmall Limited consists of a professional team with an average of over 10 year of expertise in the distribution of electronic components. Based in Hongkong, we have already established firm and mutual-benefit business relationships with customers from,Europe,America and south Asia,supplying obsolete and hard-to-find components to meet their specific needs.

With the principle of “Quality Parts,Customers Priority,Honest Operation,and Considerate Service”,our business mainly focus on the distribution of electronic components. Line cards we deal with include Microchip,ALPS,ROHM,Xilinx,Pulse,ON,Everlight and Freescale. Main products comprise IC,Modules,Potentiometer,IC Socket,Relay,Connector.Our parts cover such applications as commercial,industrial, and automotives areas.

We are looking forward to setting up business relationship with you and hope to provide you with the best service and solution. Let us make a better world for our industry!



## Contact us

Tel: +86-755-8981 8866 Fax: +86-755-8427 6832

Email & Skype: info@chipsmall.com Web: www.chipsmall.com

Address: A1208, Overseas Decoration Building, #122 Zhenhua RD., Futian, Shenzhen, China





#### General Description

The XR76203, XR76205 and XR76208 are synchronous step-down regulators combining the controller, drivers, bootstrap diode and MOSFETs in a single package for point-of-load supplies. The XR76203, XR76205 and XR76208 have load current ratings of 3A, 5A and 8A respectively. A wide 5V to 40V input voltage range allows for single supply operation from industry standard 24V ±10%, 18V-36V, and rectified 18VAC and 24VAC rails.

With a proprietary emulated current mode Constant On-Time (COT) control scheme, the XR76203, XR76205 and XR76208 provide extremely fast line and load transient response using ceramic output capacitors. They require no loop compensation, simplifying circuit implementation and reducing overall component count. The control loop also provides 0.07% load and 0.15% line regulation and maintains constant operating frequency. A selectable power saving mode allows the user to operate in discontinuous conduction mode (DCM) at light current loads thereby significantly increasing the converter efficiency.

A host of protection features, including over-current, over-temperature, short-circuit and UVLO, helps achieve safe operation under abnormal operating conditions.

The XR76203/5/8 are available in a RoHS-compliant, green/halogen-free space-saving QFN 5x5mm package.

#### FEATURES

- Controller, drivers, bootstrap diode and MOSFETs integrated in one package
- 3A, 5A and 8A Step Down Regulators
  - Wide 5V to 40V Input Voltage Range
  - >0.6V Adjustable Output Voltage
- Proprietary Constant On-Time Control
  - No Loop Compensation Required
  - Stable Ceramic Output Capacitor Operation
  - Programmable 200ns to 2µs On-Time
  - Constant 100kHz to 800kHz Frequency
- Selectable CCM or CCM/DCM
  - CCM/DCM for high efficiency at light-load
  - CCM for constant frequency at light-load
- Programmable Hiccup Current Limit with Thermal Compensation
- Precision Enable and Power Good flag
- Programmable Soft-start
- 30-pin 5x5mm QFN package

#### APPLICATIONS

- Distributed Power Architecture
- Point-of-Load Converters
- Power Supply Modules
- FPGA, DSP, and Processor Supplies
- Base Stations, Switches/Routers, and Servers

Ordering Information – [back page](#)

#### Typical Application

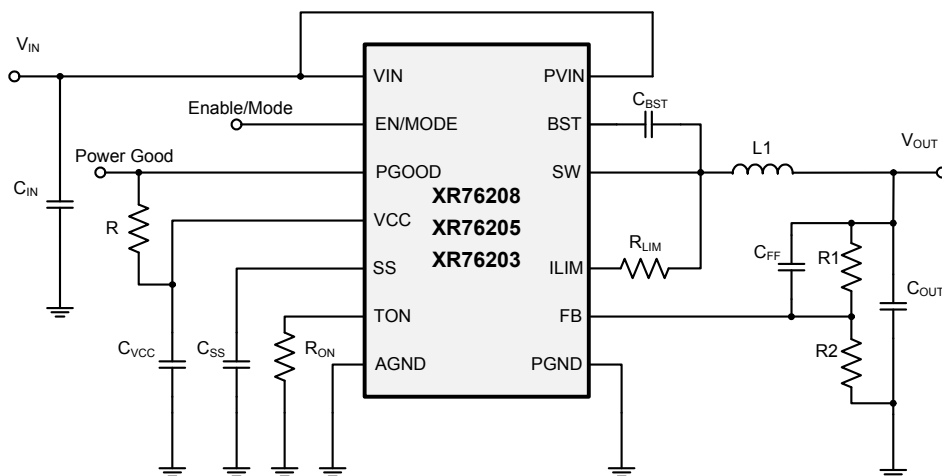

Line Regulation

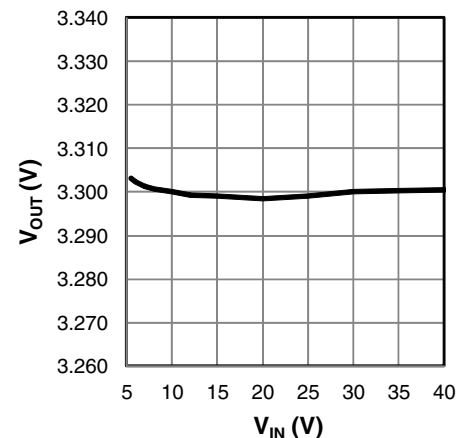

## Absolute Maximum Ratings

Stresses beyond the limits listed below may cause permanent damage to the device. Exposure to any Absolute Maximum Rating condition for extended periods may affect device reliability and lifetime.

$PV_{IN}, V_{IN}$	-0.3V to 43V
$V_{CC}$	-0.3V to 6.0V
BST	-0.3V to 48V <sup>1</sup>
BST-SW	-0.3V to 6V
SW, ILIM	-1V to 43V <sup>1, 2</sup>
ALL other pins	-0.3V to $V_{CC}+0.3V$
Storage Temperature	-65°C to +150°C
Junction Temperature	150°C
Power Dissipation	Internally Limited
Lead Temperature (Soldering, 10 sec)	300°C
ESD Rating (HBM - Human Body Model)	2kV

## Operating Conditions

$PV_{IN}$	5V to 40V
$V_{IN}$	5V to 40V
SW, ILIM	-1V to 40V <sup>1</sup>
PGOOD, $V_{CC}$ , $T_{ON}$ , SS, EN, FB	-0.3V to 5.5V
Switching Frequency	100kHz to 800kHz <sup>3</sup>
Junction Temperature Range	-40°C to +125°C
XR76203 JEDEC51 Package Thermal Resistance, $\theta_{JA}$	28°C/W
XR76205 JEDEC51 Package Thermal Resistance, $\theta_{JA}$	26°C/W
XR76208 JEDEC51 Package Thermal Resistance, $\theta_{JA}$	25°C/W
XR76203 Package Power Dissipation at 25°C	3.6W
XR76205 Package Power Dissipation at 25°C	3.8W
XR76208 Package Power Dissipation at 25°C	4.0W

Note 1: No external voltage applied.

Note 2: SW pin's minimum DC range is -1V, transient is -5V for less than 50ns.

Note 3: Recommended frequency

## Electrical Characteristics

Unless otherwise noted:  $T_J = 25^\circ\text{C}$ ,  $V_{IN} = 24\text{V}$ ,  $BST = V_{CC}$ ,  $SW = AGND = PGND = 0\text{V}$ ,  $C_{VCC} = 4.7\mu\text{F}$ . Limits applying over the full operating temperature range are denoted by a “•”

Symbol	Parameter	Conditions		Min	Typ	Max	Units
Power Supply Characteristics							
$V_{IN}$	Input Voltage Range	$V_{CC}$ regulating	•	5.5		40	V
$I_{VIN}$	$V_{IN}$ Input Supply Current	Not switching, $V_{IN} = 24\text{V}$ , $V_{FB} = 0.7\text{V}$	•		0.7	2	mA
$I_{VIN}$	$V_{IN}$ Input Supply Current (XR76203)	$f = 300\text{kHz}$ , $R_{ON} = 215\text{k}$ , $V_{FB} = 0.58\text{V}$			12		mA
$I_{VIN}$	$V_{IN}$ Input Supply Current (XR76205)	$f = 300\text{kHz}$ , $R_{ON} = 215\text{k}$ , $V_{FB} = 0.58\text{V}$			15		mA
$I_{VIN}$	$V_{IN}$ Input Supply Current (XR76208)	$f = 300\text{kHz}$ , $R_{ON} = 215\text{k}$ , $V_{FB} = 0.58\text{V}$			19		mA
$I_{OFF}$	Shutdown Current	Enable = 0V, $V_{IN} = 12\text{V}$			1		$\mu\text{A}$
Enable and Under-Voltage Lock-Out UVLO							
$V_{IH\_EN\_1}$	EN Pin Rising Threshold		•	1.8	1.9	2.0	V
$V_{EN\_H\_1}$	EN Pin Hysteresis				70		mV
$V_{IH\_EN\_2}$	EN Pin Rising Threshold for DCM/CCM operation		•	2.8	3.0	3.1	V
$V_{EN\_H\_2}$	EN Pin Hysteresis				100		mV



Symbol	Parameter	Conditions		Min	Typ	Max	Units
	VCC UVLO Start Threshold, Rising Edge		•	4.00	4.25	4.40	V
	VCC UVLO Hysteresis				230		mV
Reference Voltage							
V <sub>REF</sub>	Reference Voltage	V <sub>IN</sub> = 5.5V to 40V, VCC regulating		0.596	0.600	0.604	V
		V <sub>IN</sub> = 5.5V to 40V, VCC regulating	•	0.594	0.600	0.606	V
	DC Line Regulation	CCM, closed loop, V <sub>IN</sub> =5.5V-40V, applies to any C <sub>OUT</sub>			±0.33		%
	DC Load Regulation	CCM, closed loop, applies to any C <sub>OUT</sub>			±0.39		%
Programmable Constant On-Time							
T <sub>ON1</sub>	On-Time 1	R <sub>ON</sub> = 237k, V <sub>IN</sub> = 40V	•	1570	1840	2120	ns
	f Corresponding to On-Time 1	V <sub>OUT</sub> = 24V, V <sub>IN</sub> = 40V, R <sub>ON</sub> = 237k	•	283	326	382	kHz
T <sub>ON(MIN)</sub>	Minimum Programmable On-Time	R <sub>ON</sub> = 14k, V <sub>IN</sub> = 40V			120		ns
T <sub>ON2</sub>	On-Time 2	R <sub>ON</sub> = 14k, V <sub>IN</sub> = 24V	•	174	205	236	ns
T <sub>ON3</sub>	On-Time 3	R <sub>ON</sub> = 35.7k, V <sub>IN</sub> = 24V	•	407	479	550	ns
	f Corresponding to On-Time 3	V <sub>OUT</sub> = 3.3V, V <sub>IN</sub> = 24V, R <sub>ON</sub> = 35.7k	•	250	287	338	kHz
	f Corresponding to On-Time 3	V <sub>OUT</sub> = 5.0V, V <sub>IN</sub> = 24V, R <sub>ON</sub> = 35.7k	•	379	435	512	kHz
	Minimum Off-Time		•		250	350	ns
Diode Emulation Mode							
	Zero Crossing Threshold	DC value measured during test			-2		mV
Soft-start							
	SS Charge Current		•	-14	-10	-6	μA
	SS Discharge Current	Fault present	•	1			mA
VCC Linear Regulator							
	VCC Output Voltage	V <sub>IN</sub> = 6V to 40V, I <sub>LOAD</sub> = 0 to 30mA	•	4.8	5.0	5.2	V
		V <sub>IN</sub> = 5V, I <sub>LOAD</sub> = 0 to 20mA	•	4.51	4.7		V
Power Good Output							
	Power Good Threshold			-10	-6.9	-5	%
	Power Good Hysteresis				1.6	4	%
	Power Good Sink Current			1			mA
Protection: OCP, OTP, Short-Circuit							
	Hiccup Timeout				110		ms
	ILIM Pin Source Current			45	50	55	μA
	ILIM Current Temperature Coefficient				0.4		%/°C
	OCP Comparator Offset		•	-8	0	+8	mV

Symbol	Parameter	Conditions		Min	Typ	Max	Units
	Current Limit Blanking	GL rising > 1V			100		ns
	Thermal Shutdown Threshold <sup>1</sup>	Rising temperature			150		°C
	Thermal Hysteresis <sup>1</sup>				15		°C
	VSCTH Feedback Pin Short-Circuit Threshold	Percent of $V_{REF}$ short circuit is active after PGOOD is asserted	•	50	60	70	%
XRP76203 Output Power Stage							
$R_{DSON}$	High-Side MOSFET $R_{DSON}$	$I_{DS} = 1A$			115	160	mΩ
	Low-Side MOSFET $R_{DSON}$				40	59	mΩ
$I_{OUT}$	Maximum Output Current		•	3A			A
XRP76205 Output Power Stage							
$R_{DSON}$	High-Side MOSFET $R_{DSON}$	$I_{DS} = 2A$			42	59	mΩ
	Low-Side MOSFET $R_{DSON}$				40	59	mΩ
$I_{OUT}$	Maximum Output Current		•	5A			A
XRP76208 Output Power Stage							
$R_{DSON}$	High-Side MOSFET $R_{DSON}$	$I_{DS} = 2A$			42	59	mΩ
	Low-Side MOSFET $R_{DSON}$				16.2	21.5	mΩ
$I_{OUT}$	Maximum Output Current		•	8A			A

Note 1: Guaranteed by design

Pin Configuration, Top View

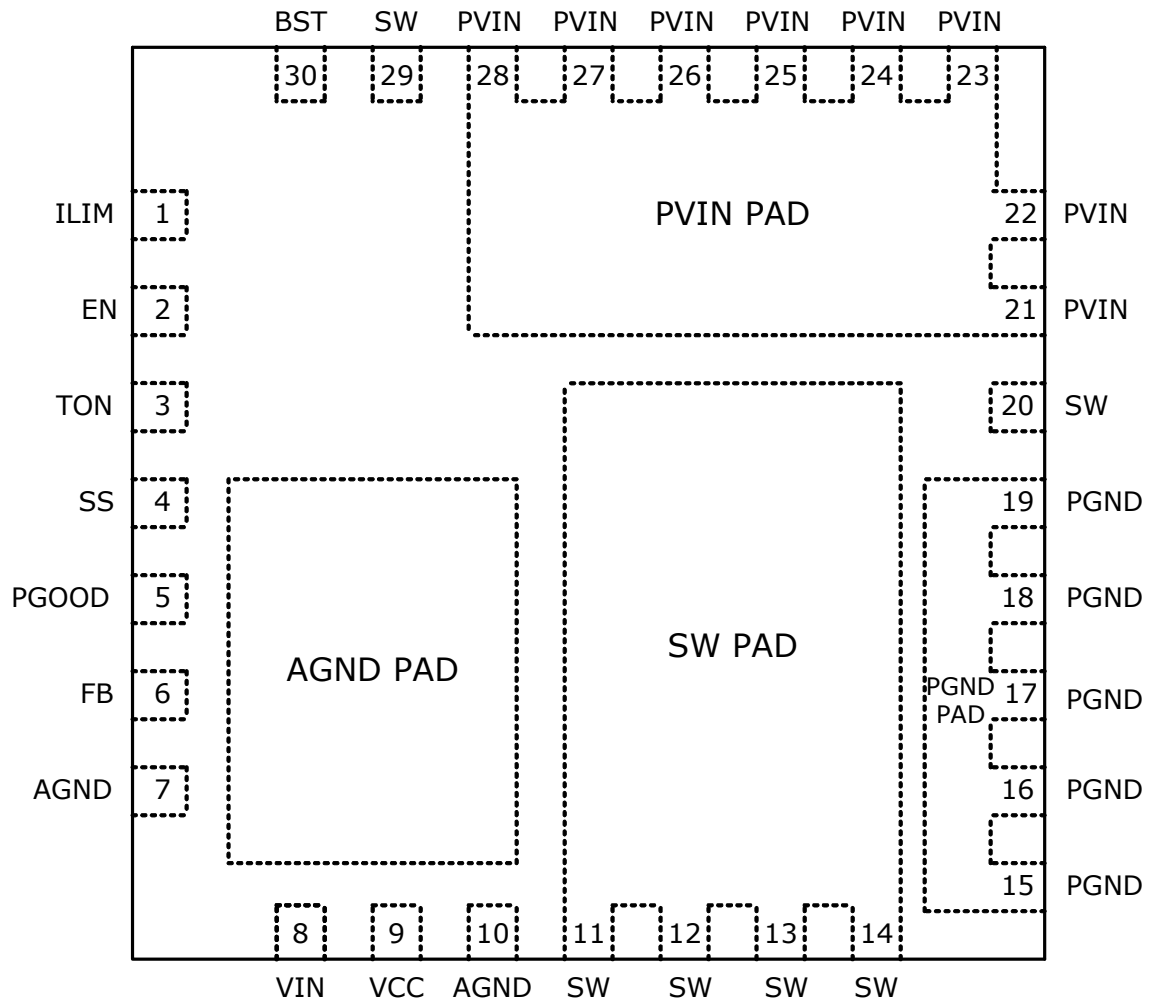

## Pin Assignments

Pin No.	Pin Name	Type	Description
1	ILIM	A	Over-current protection programming. Connect with a resistor to SW.
2	EN/MODE	I	Precision enable pin. Pulling this pin above 1.9V will turn the regulator on and it will operate in CCM. If the voltage is raised above 3.0V then the regulator will operate in DCM/CCM depending on load
3	TON	A	Constant on-time programming pin. Connect with a resistor to AGND.
4	SS	A	Soft-Start pin. Connect an external capacitor between SS and AGND to program the soft-start rate based on the 10uA internal source current.
5	PGOOD	O, OD	Power-good output. This open-drain output is pulled low when $V_{OUT}$ is outside the regulation.
6	FB	A	Feedback input to feedback comparator. Connect with a set of resistors to $V_{OUT}$ and AGND in order to program $V_{OUT}$ .
7, 10, AGND Pad	AGND	A	Signal ground for control circuitry. Connect AGND Pad with a short trace to pins 7 and 10.
8	VIN	A	Supply input for the regulator's LDO. Normally it is connected to PVIN.
9	VCC	A	The output of regulator's LDO. For operation using a 5V rail, VCC should be shorted to VIN.
11-14, 20, 29, SW Pad	SW	PWR	Switch node. Drain of the low-side N-channel MOSFET. Source of the high-side MOSFET is wire-bonded to the SW Pad. Pins 20 and 29 are internally connected to SW pad.
15-19, PGND Pad	PGND	PWR	Ground of the power stage. Should be connected to the system's power ground plane. Source of the low-side MOSFET is wire-bonded to PGND Pad.
21-28, PVIN Pad	PVIN	PWR	Input voltage for power stage. Drain of the high-side N-channel MOSFET.
30	BST	A	High-side driver supply pin. Connect a bootstrap capacitor between BST and pin 29.

Type: A = Analog, I = Input, O = Output, I/O = Input/Output, PWR = Power, OD = Open-Drain





### Typical Performance Characteristics

Unless otherwise noted:  $V_{IN} = 24V$ ,  $V_{OUT} = 3.3V$ ,  $I_{OUT} = 8A$ ,  $f = 400kHz$ ,  $T_A = 25^\circ C$ . Schematic from the application information section.

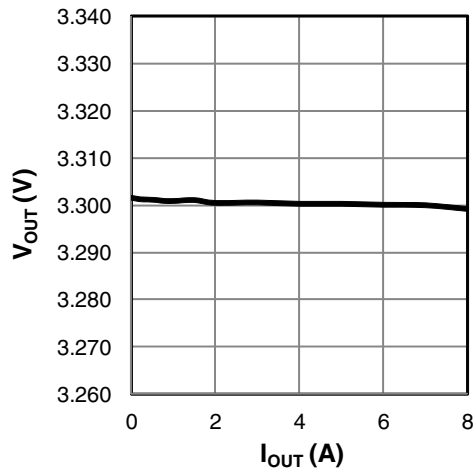

Figure 1: Load Regulation

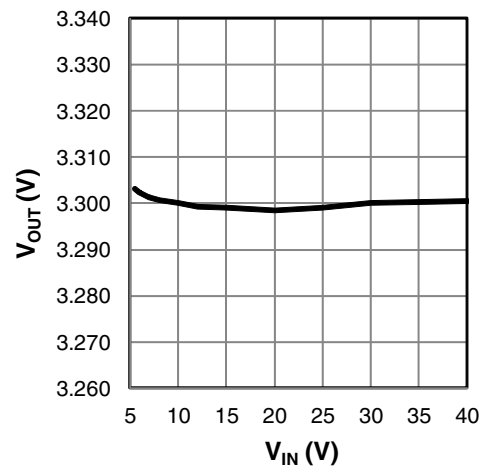

Figure 2: Line regulation

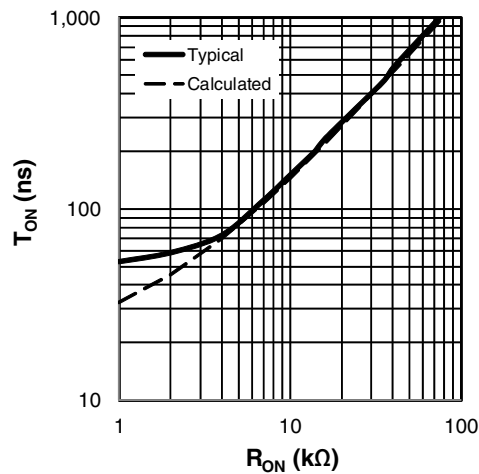

Figure 3:  $T_{ON}$  versus  $R_{ON}$

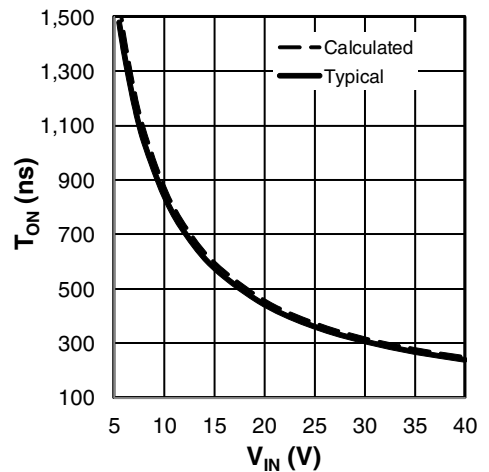

Figure 4:  $T_{ON}$  versus  $V_{IN}$ ,  $R_{ON} = 27.4k$

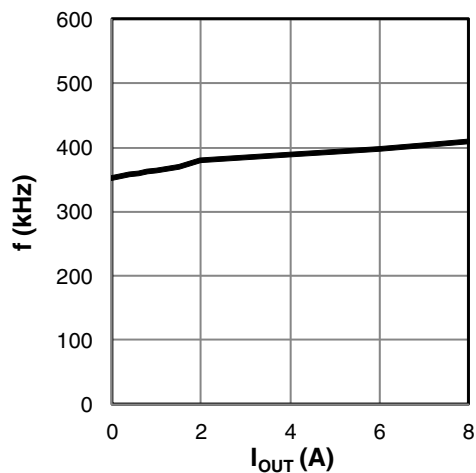

Figure 5: frequency versus  $I_{OUT}$

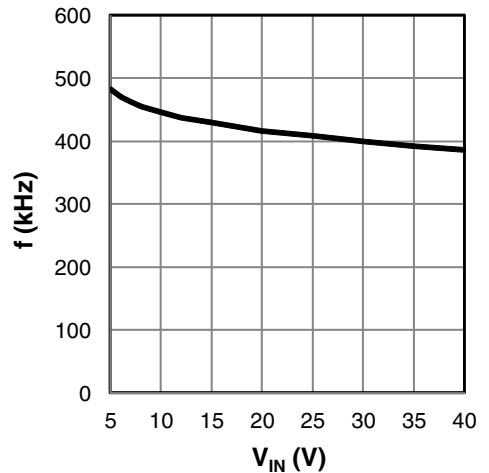

Figure 6: frequency versus  $V_{IN}$

### Typical Performance Characteristics

Unless otherwise noted:  $V_{IN} = 24V$ ,  $V_{OUT} = 3.3V$ ,  $I_{OUT} = 8A$ ,  $f = 400kHz$ ,  $T_A = 25^\circ C$ . Schematic from the application information section.

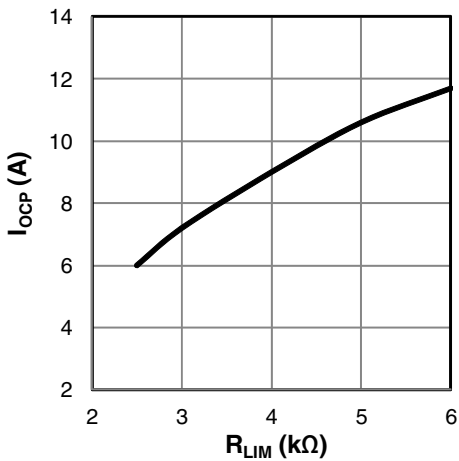

Figure 7: XR76208  $I_{OCP}$  versus  $R_{LIM}$

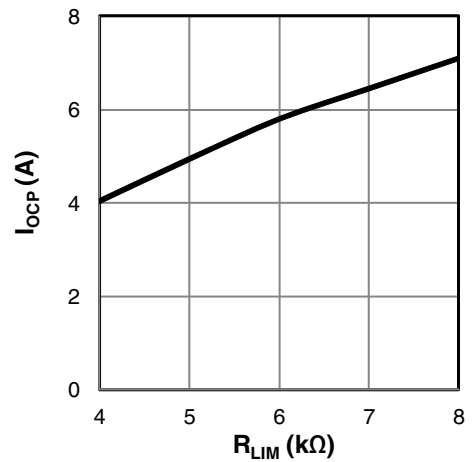

Figure 8: XR76205  $I_{OCP}$  versus  $R_{LIM}$

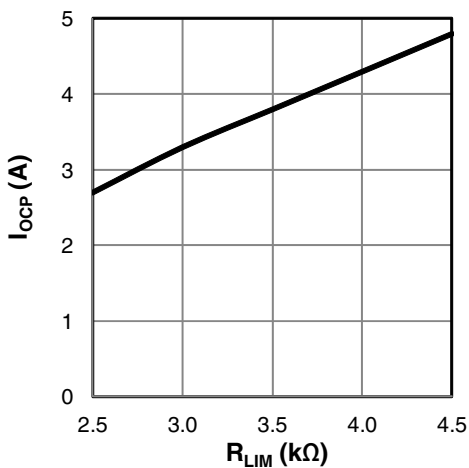

Figure 9: XR76203  $I_{OCP}$  versus  $R_{LIM}$

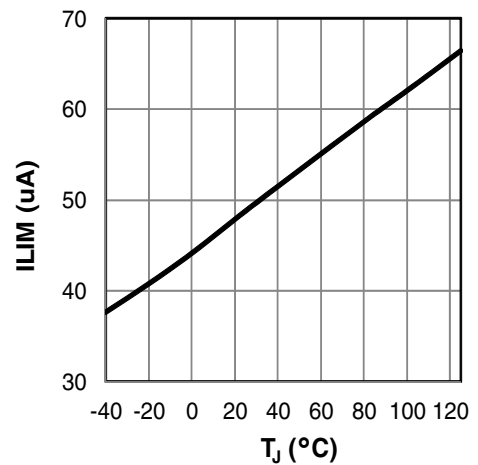

Figure 10:  $I_{LIM}$  versus temperature

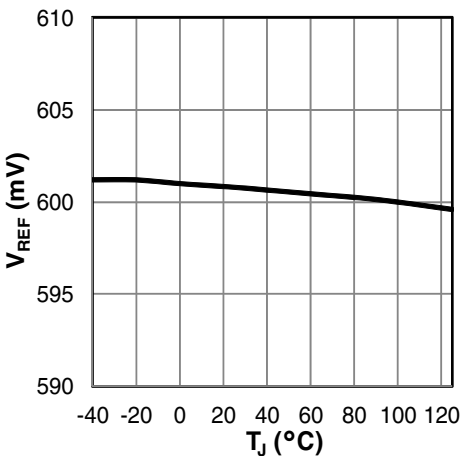

Figure 11:  $V_{REF}$  versus temperature

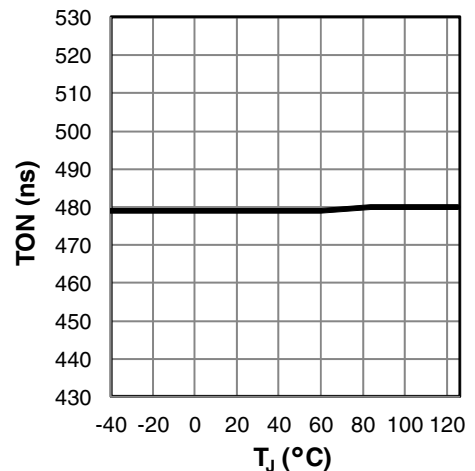

Figure 12:  $T_{ON}$  versus temperature,  $R_{ON} = 35.7k\Omega$

### Typical Performance Characteristics

Unless otherwise noted:  $V_{IN} = 24V$ ,  $V_{OUT} = 3.3V$ ,  $I_{OUT} = 8A$ ,  $f = 400kHz$ ,  $T_A = 25^\circ C$ . Schematic from the application information section.

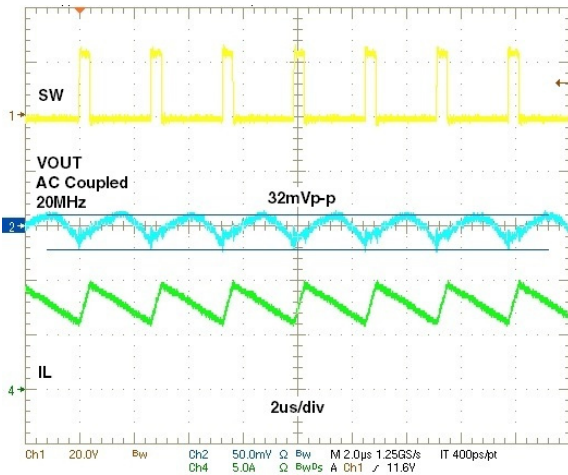

Figure 13: Steady state,  $I_{OUT} = 8A$

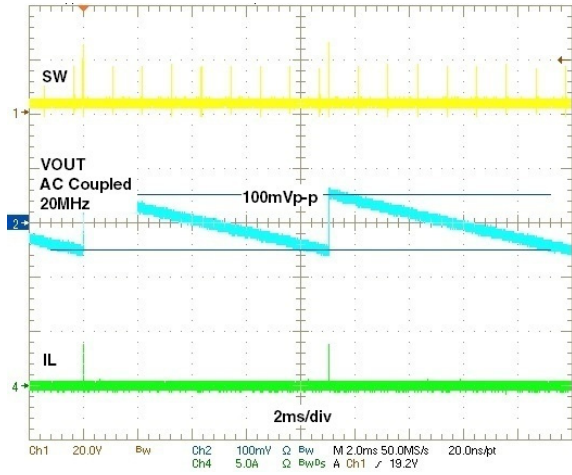

Figure 14: Steady state, DCM,  $I_{OUT} = 0A$

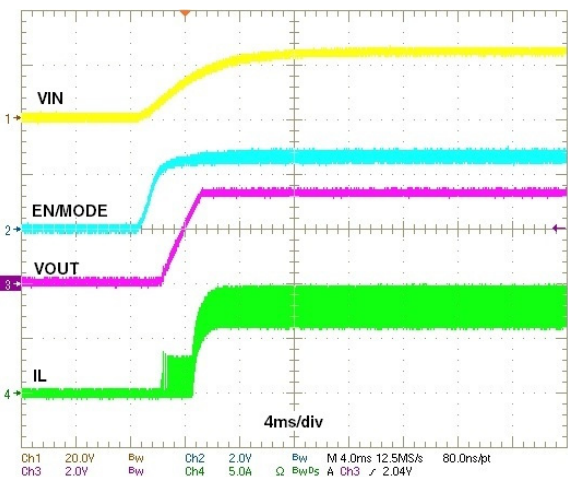

Figure 15: Power up, Forced CCM

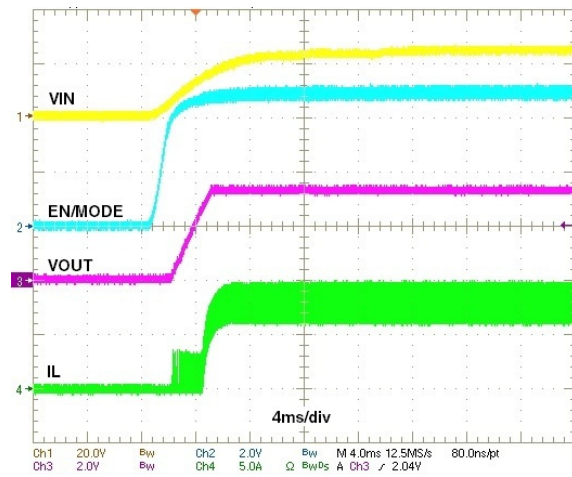

Figure 16: Power up, DCM/CCM

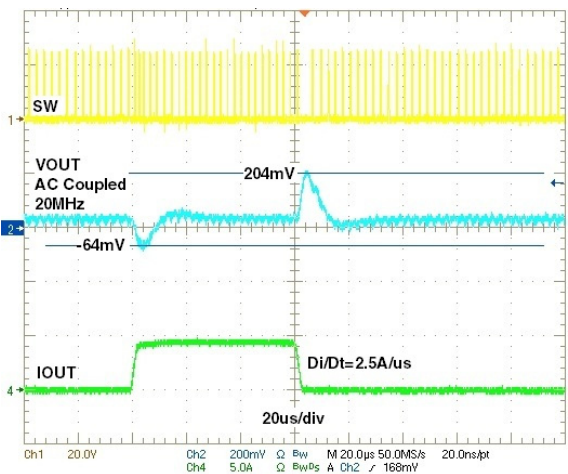

Figure 17: Load step, Forced CCM, 0A-4A-0A

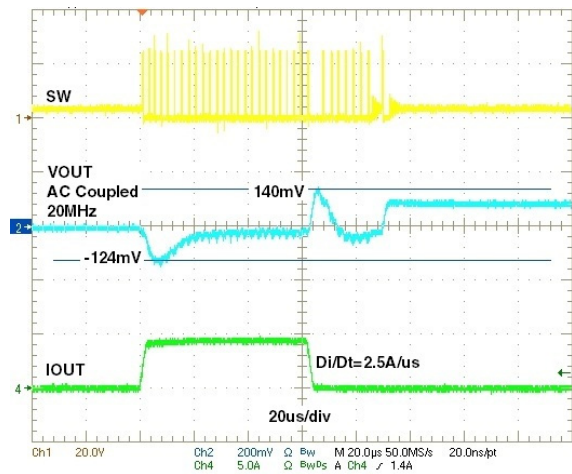

Figure 18: Load step, DCM/CCM, 0A-4A-0A

## Efficiency

Unless otherwise noted:  $T_{AMBIENT} = 25^{\circ}\text{C}$ , No Air flow,  $f=400\text{kHz}$ , Inductor losses are included, Schematic from the application information section.

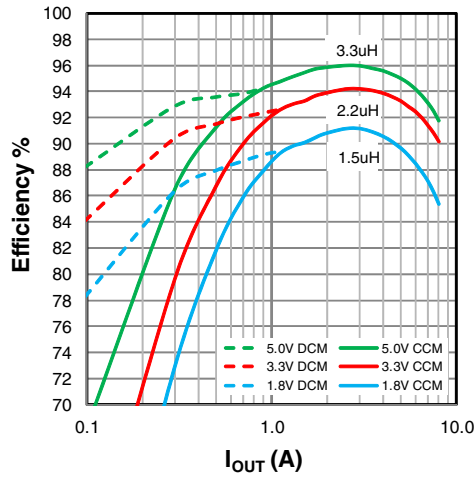

Figure 19: XR76208 efficiency,  $V_{IN}=12\text{V}$

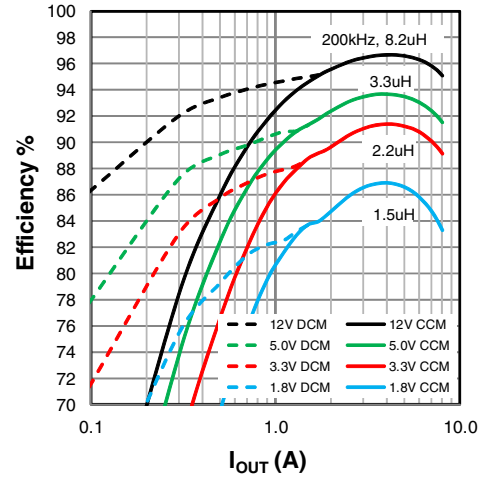

Figure 20: XR76208 efficiency,  $V_{IN}=24\text{V}$

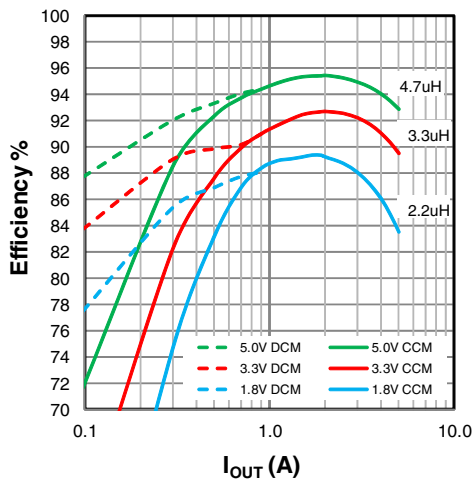

Figure 21: XR76205 efficiency,  $V_{IN}=12\text{V}$

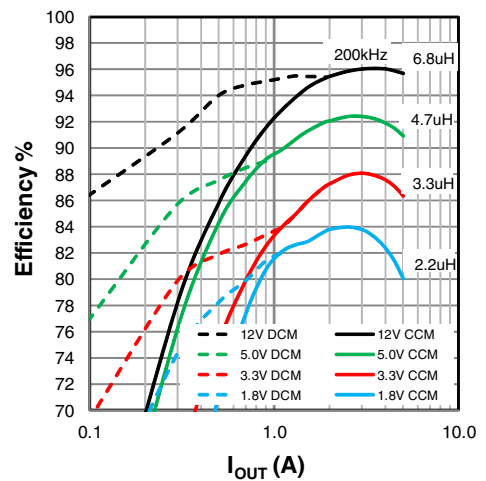

Figure 22: XR76205 efficiency,  $V_{IN}=24\text{V}$

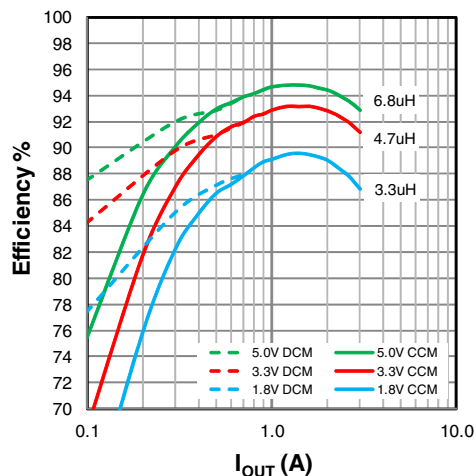

Figure 23: XR76203 efficiency,  $V_{IN}=12\text{V}$

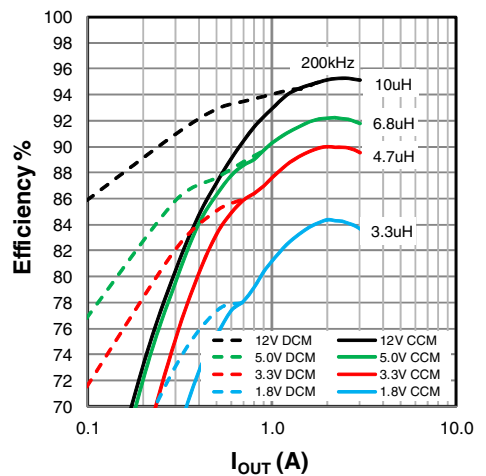

Figure 24: XR76203 efficiency,  $V_{IN}=24\text{V}$

## Thermal Derating

Unless otherwise noted: No Air flow,  $f=400\text{kHz}$ , Schematic from the application information section.

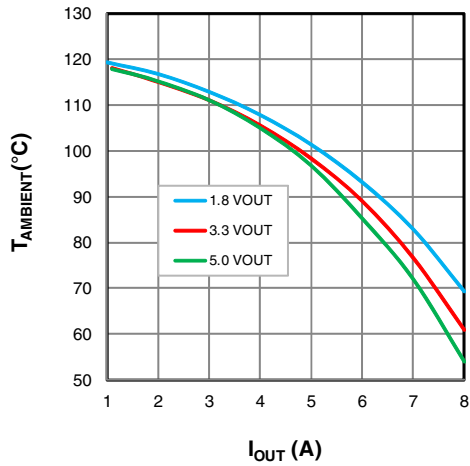

Figure 25: XR76208,  $V_{IN}=12\text{V}$

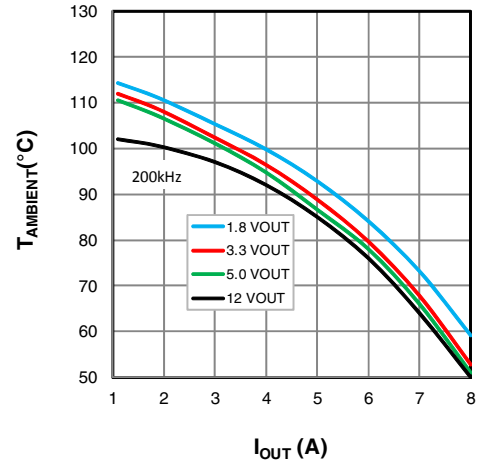

Figure 26: XR76208,  $V_{IN}=24\text{V}$

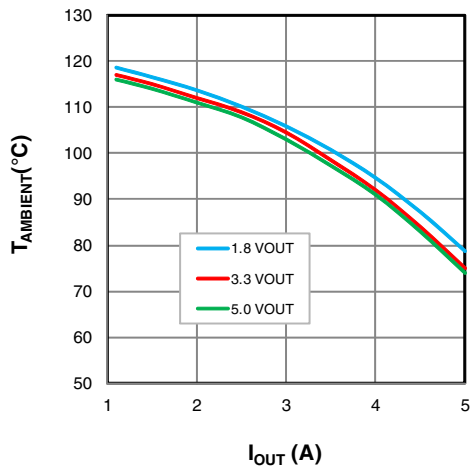

Figure 27: XR76205,  $V_{IN}=12\text{V}$

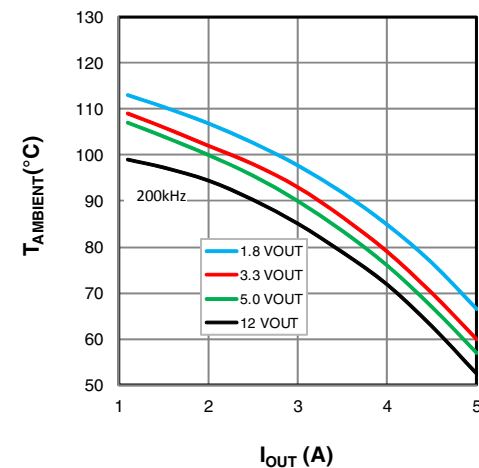

Figure 28: XR76205,  $V_{IN}=24\text{V}$

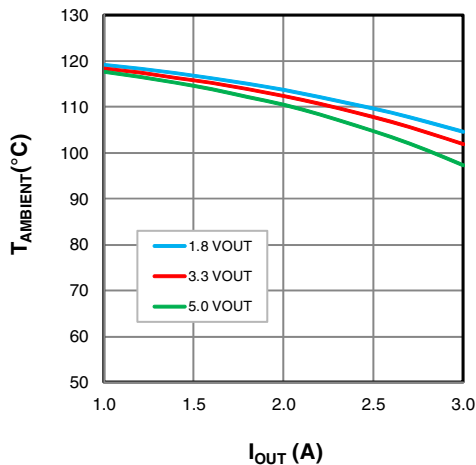

Figure 29: XR76203,  $V_{IN}=12\text{V}$

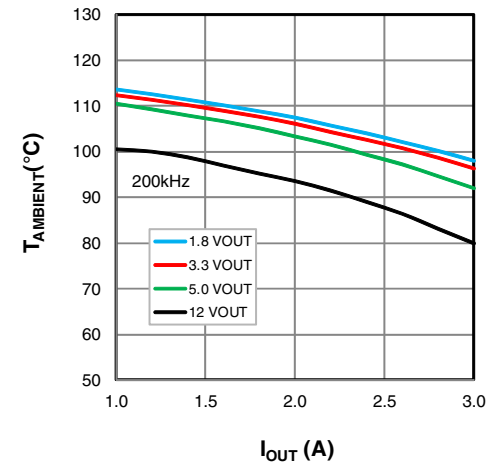

Figure 30: XR76203,  $V_{IN}=24\text{V}$

## Functional Description

XR76203, XR76205 and XR76208 are synchronous step-down proprietary emulated current-mode Constant On-Time (COT) regulators. The on-time, which is programmed via  $R_{ON}$ , is inversely proportional to  $V_{IN}$  and maintains a nearly constant frequency. The emulated current-mode control is stable with ceramic output capacitors.

Each switching cycle begins with GH signal turning on the high-side (control) FET for a preprogrammed time. At the end of the on-time, the high-side FET is turned off and the low-side (synchronous) FET is turned on for a preset minimum time (250ns nominal). This parameter is termed Minimum Off-Time. After the minimum off-time, the voltage at the feedback pin FB is compared to an internal voltage ramp at the feedback comparator. When  $V_{FB}$  drops below the ramp voltage, the high-side FET is turned on and the cycle repeats. This voltage ramp constitutes an emulated current ramp and makes possible the use of ceramic capacitors, in addition to other capacitor types, for output filtering.

### Enable/Mode Input (EN/MODE)

EN/MODE pin accepts a tri-level signal that is used to control turn on/off. It also selects between two modes of operation: 'Forced CCM' and 'DCM/CCM'. If EN is pulled below 1.8V, the Regulator shuts down. A voltage between 2.0V and 2.8V selects the Forced CCM mode which will run the Regulator in continuous conduction at all times. A voltage higher than 3.1V selects the DCM/CCM mode which will run the Regulator in discontinuous conduction at light loads.

### Selecting the Forced CCM Mode

In order to set the Regulator to operate in Forced CCM, a voltage between 2.0V and 2.8V must be applied to EN/MODE. This can be achieved with an external control signal that meets the above voltage requirement. Where an external control is not available, the EN/MODE can be derived from  $V_{IN}$ . If  $V_{IN}$  is well regulated, use a resistor divider and set the voltage to 2.5V. If  $V_{IN}$  varies over a wide range, the circuit shown in figure 31 can be used to generate the required voltage. Note that at  $V_{IN}$  of 5.5V and 40V the nominal Zener voltage is 4.0V and 5.0V respectively. Therefore for  $V_{IN}$  in the range of 5.5V to 40V, the circuit shown in figure 31 will generate  $V_{EN}$  required for Forced CCM.

### Selecting the DCM/CCM Mode

In order to set the Regulator operation to DCM/CCM, a voltage between 3.1V and 5.5V must be applied to EN/MODE pin. If an external control signal is available, it can be directly connected to EN/MODE. In applications where an external control is not available, EN/MODE input can be

derived from  $V_{IN}$ . If  $V_{IN}$  is well regulated, use a resistor divider and set the voltage to 4V. If  $V_{IN}$  varies over a wide range, the circuit shown in figure 32 can be used to generate the required voltage.

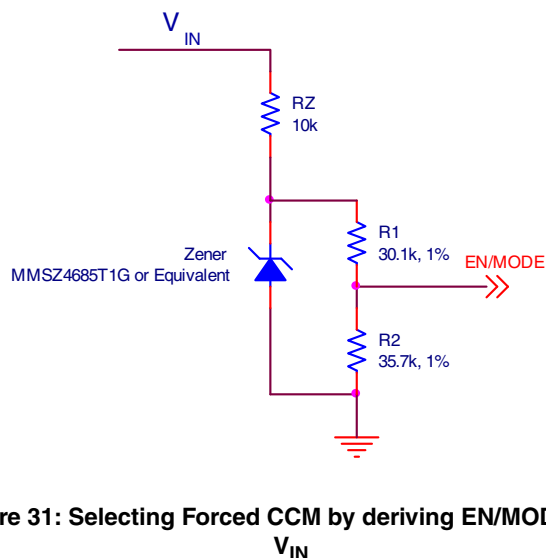

Figure 31: Selecting Forced CCM by deriving EN/MODE from  $V_{IN}$

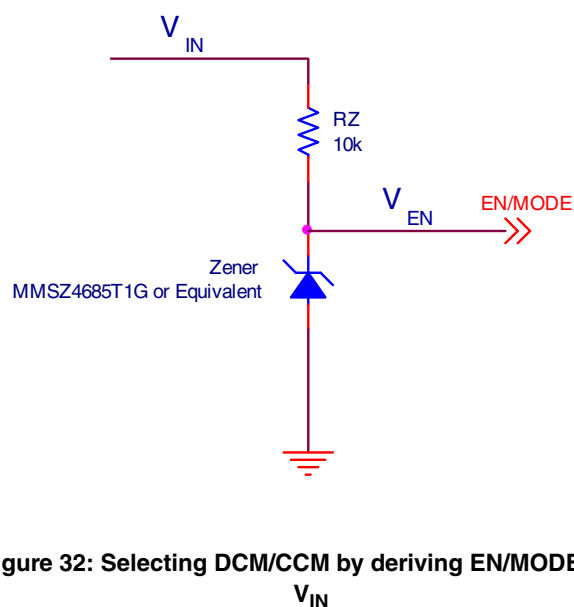

Figure 32: Selecting DCM/CCM by deriving EN/MODE from  $V_{IN}$



### Programming the On-Time

The On-Time  $T_{ON}$  is programmed via resistor  $R_{ON}$  according to following equation:

$$R_{ON} = \frac{V_{IN} \times [T_{ON} - (25 \times 10^{-9})]}{3.05 \times 10^{-10}}$$

where  $T_{ON}$  is calculated from:

$$T_{ON} = \frac{V_{OUT}}{V_{IN} \times f \times Eff}$$

where:

$f$  is the desired switching frequency at nominal  $I_{OUT}$

$Eff$  is the Regulator efficiency corresponding to nominal  $I_{OUT}$  shown in figures 19-24

Substituting for  $T_{ON}$  in the first equation we get:

$$R_{ON} = \frac{\left(\frac{V_{OUT}}{f \times Eff}\right) - [(25 \times 10^{-9}) \times V_{IN}]}{3.05 \times 10^{-10}}$$

### Over-Current Protection (OCP)

If load current exceeds the programmed over-current,  $I_{OCP}$  for four consecutive switching cycles, the Module enters hiccup mode of operation. In hiccup, the MOSFET gates are turned off for 110ms (hiccup timeout). Following the hiccup timeout, a soft-start is attempted. If OCP persists, hiccup timeout will repeat. The Module will remain in hiccup mode until load current is reduced below the programmed  $I_{OCP}$ . In order to program the over-current protection, use the following equation:

$$RLIM = \frac{(I_{OCP} \times RDS) + 8mV}{ILIM}$$

Where:

$RLIM$  is resistor value for programming  $I_{OCP}$

$I_{OCP}$  is the over-current threshold to be programmed

$RDS$  is the MOSFET rated On Resistance; XR76208=21.5mΩ, XR76205=59mΩ, XR76203=59mΩ

8mV is the OCP comparator maximum offset

$ILIM$  is the internal current that generates the necessary OCP comparator threshold (use 45μA).

Note that  $ILIM$  has a positive temperature coefficient of 0.4%/°C (figure 10). This is meant to roughly match and compensate for positive temperature coefficient of the synchronous FET. Graph of typical  $I_{OCP}$  versus  $RLIM$  is shown in figure 7-9. Maximum allowable  $RLIM$  for XR76205 is 8.06kΩ.

### Short-Circuit Protection (SCP)

If the output voltage drops below 60% of its programmed value, the Module will enter hiccup mode. Hiccup will persist until short-circuit is removed. SCP circuit becomes active after PGOOD asserts high.

### Over-Temperature (OTP)

OTP triggers at a nominal die temperature of 150°C. The gate of switching FET and synchronous FET are turned off. When die temperature cools down to 135°C, soft-start is initiated and operation resumes.

### Programming the Output Voltage

Use an external voltage divider as shown in the Application Circuit to program the output voltage  $V_{OUT}$ .

$$R1 = R2 \times \left(\frac{V_{OUT}}{0.6} - 1\right)$$

where  $R2$  has a nominal value of 2kΩ.

### Programming the Soft-start

Place a capacitor  $CSS$  between the SS and AGND pins to program the soft-start. In order to program a soft-start time of  $TSS$ , calculate the required capacitance  $CSS$  from the following equation:

$$CSS = TSS \times \left(\frac{10\mu A}{0.6V}\right)$$

### Feed-Forward Capacitor ( $C_{FF}$ )

A feed-forward capacitor ( $C_{FF}$ ) may be necessary depending on the Equivalent Series Resistance (ESR) of  $C_{OUT}$ . If only ceramic output capacitors are used for  $C_{OUT}$  then a  $C_{FF}$  is necessary. Calculate  $C_{FF}$  from:

$$C_{FF} = \frac{1}{2 \times \pi \times R1 \times 7 \times f_{LC}}$$

where:

$R1$  is the resistor that  $C_{FF}$  is placed in parallel with

$f_{LC}$  is the frequency of output filter double-pole

$f_{LC}$  frequency must be less than 11kHz when using ceramic  $C_{OUT}$ . If necessary, increase  $L$  and/or  $C_{OUT}$  in order to meet this constraint.

When using capacitors with higher ESR, such as PANASONIC TPE series, a  $C_{FF}$  is not required provided following conditions are met:

1. The frequency of output filter LC double-pole  $f_{LC}$  should be less than 11kHz.
2. The frequency of ESR Zero  $f_{Zero,ESR}$  should be at least five times larger than  $f_{LC}$ .

Note that if  $f_{Zero,ESR}$  is less than  $5 \times f_{LC}$ , then it is recommended to set the  $f_{LC}$  at less than 2kHz.  $C_{FF}$  is still not required.

### Maximum Allowable Voltage Ripple at FB pin

Note that the steady-state voltage ripple at feedback pin FB ( $V_{FB,RIPPLE}$ ) must not exceed 50mV in order for the Regulator to function correctly. If  $V_{FB,RIPPLE}$  is larger than 50mV then  $C_{OUT}$  should be increased as necessary in order to keep the  $V_{FB,RIPPLE}$  below 50mV.

### Feed-Forward Resistor ( $R_{FF}$ )

Poor PCB layout can cause FET switching noise at the output and may couple to the FB pin via  $C_{FF}$ . Excessive noise at FB will cause poor load regulation. To solve this problem place a resistor  $R_{FF}$  in series with  $C_{FF}$ .  $R_{FF}$  value up to 2% of  $R1$  is acceptable.

Application Circuit, XR76208

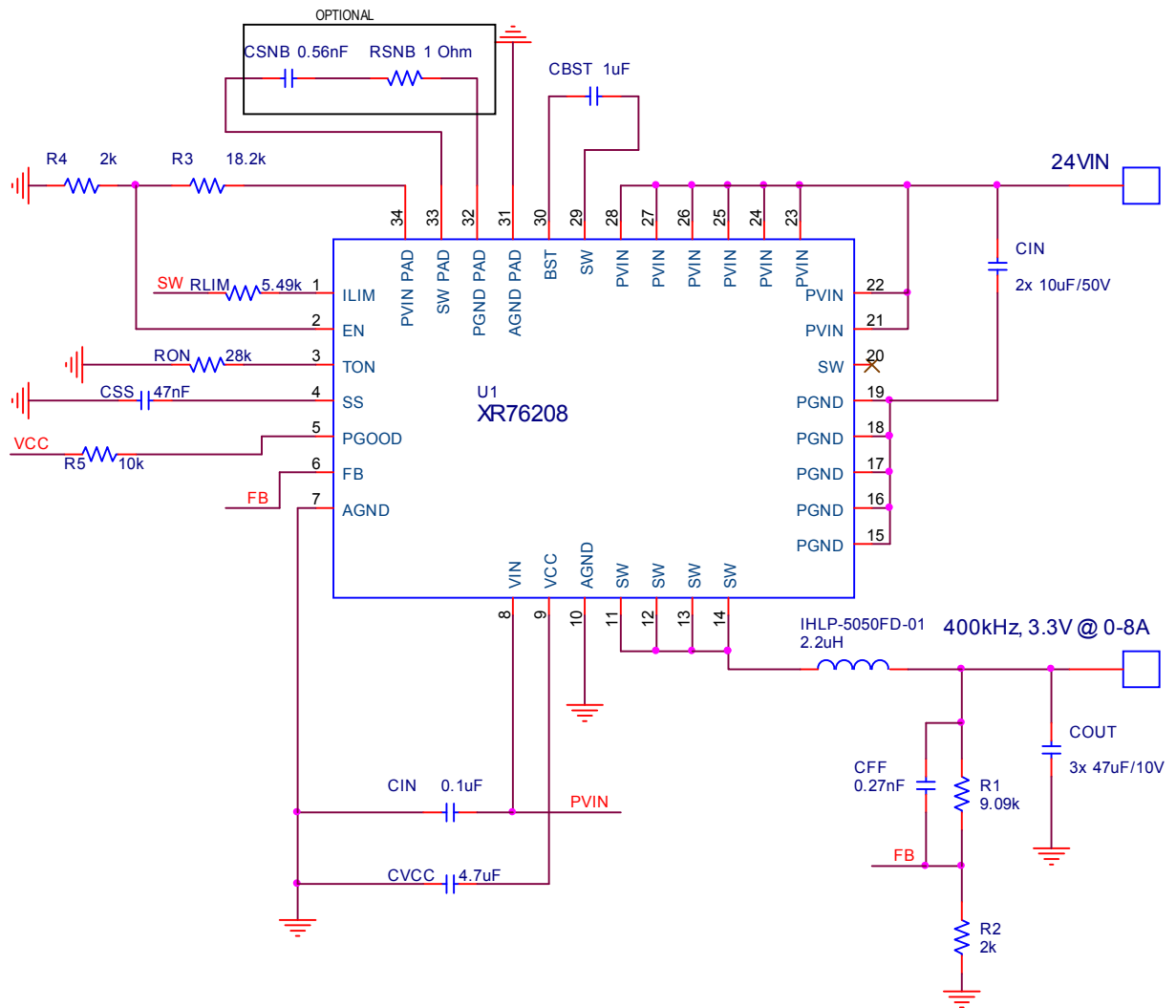

Application Circuit, XR76205

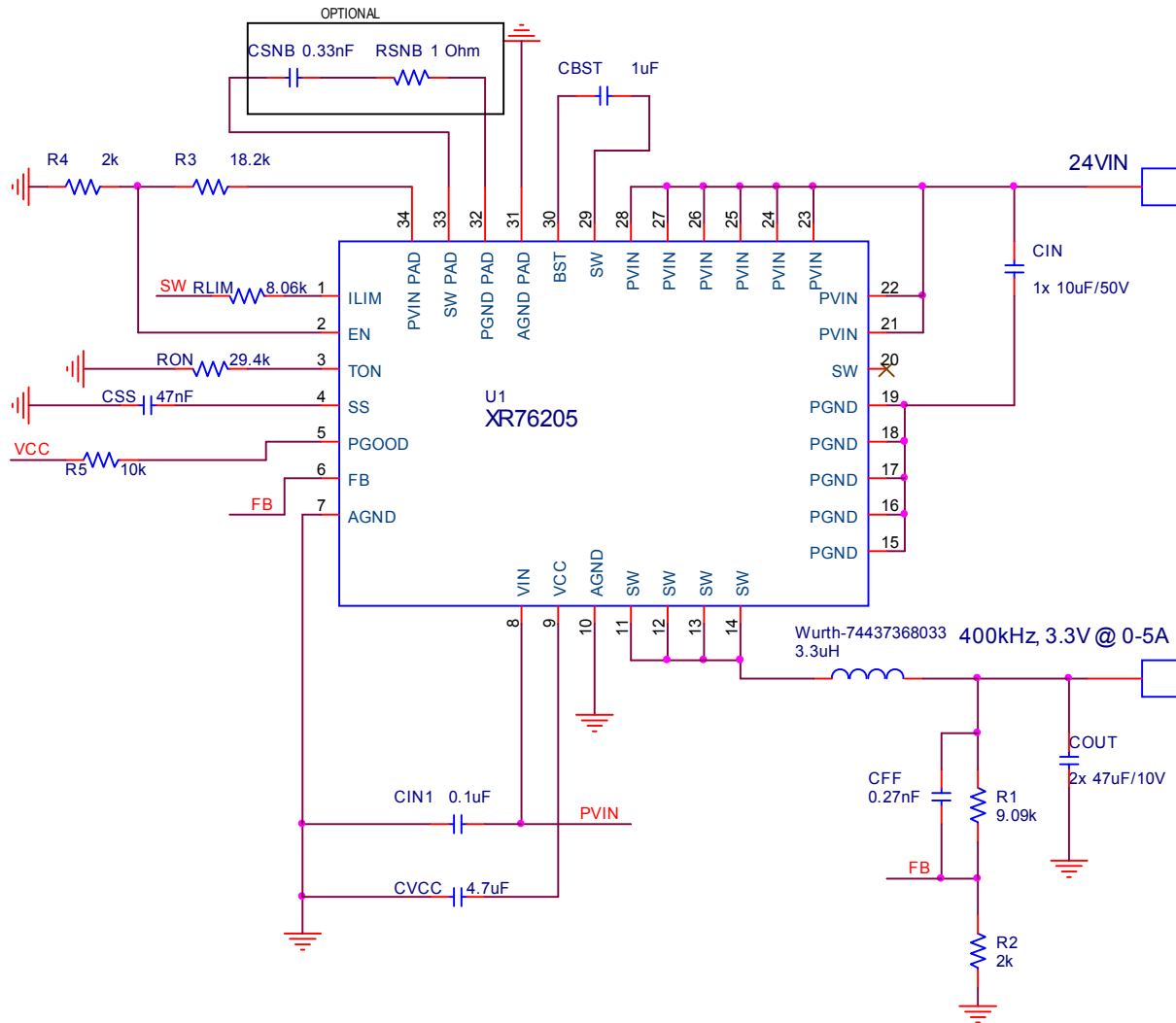

Application Circuit, XR76203

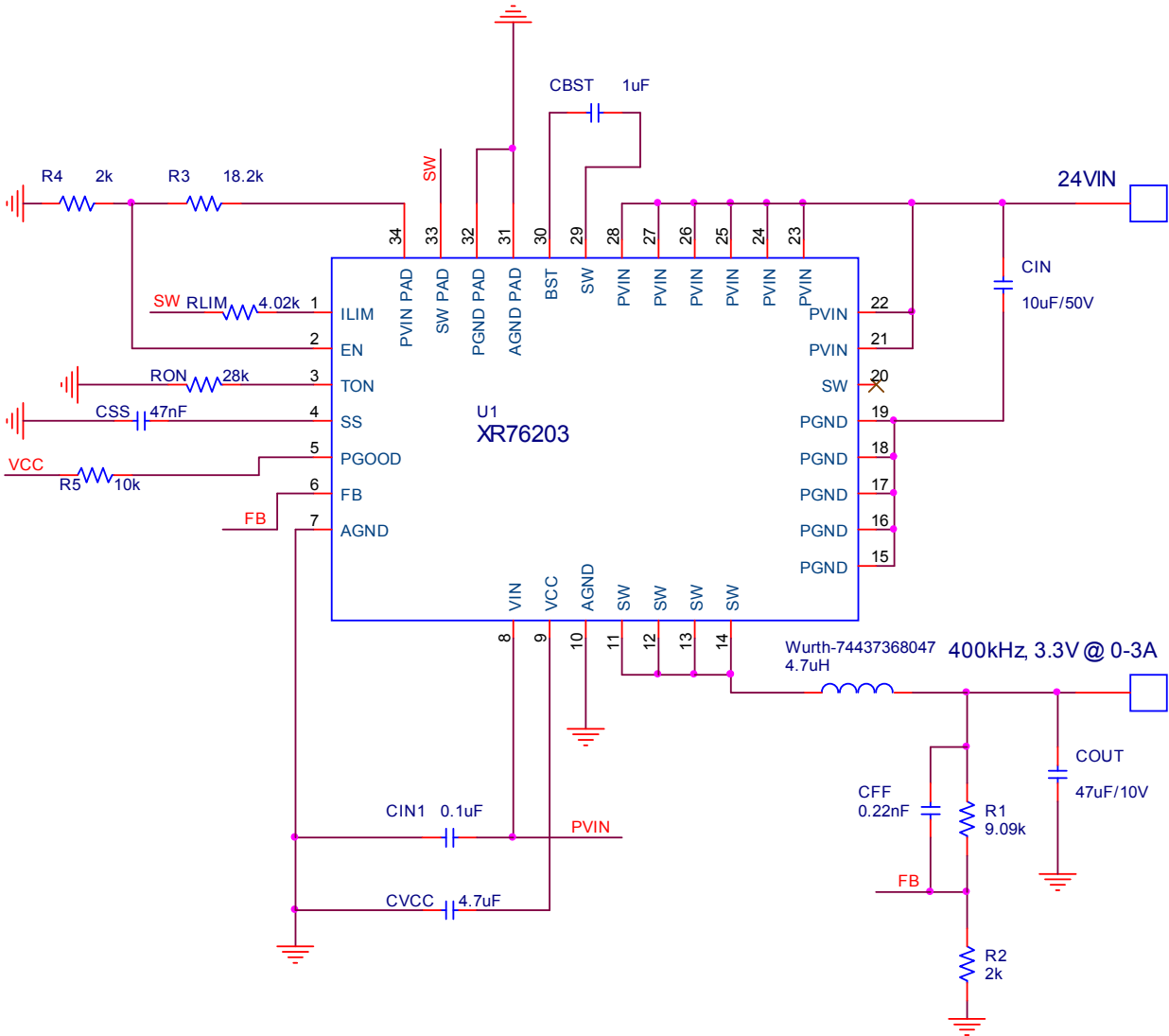

Mechanical Dimensions

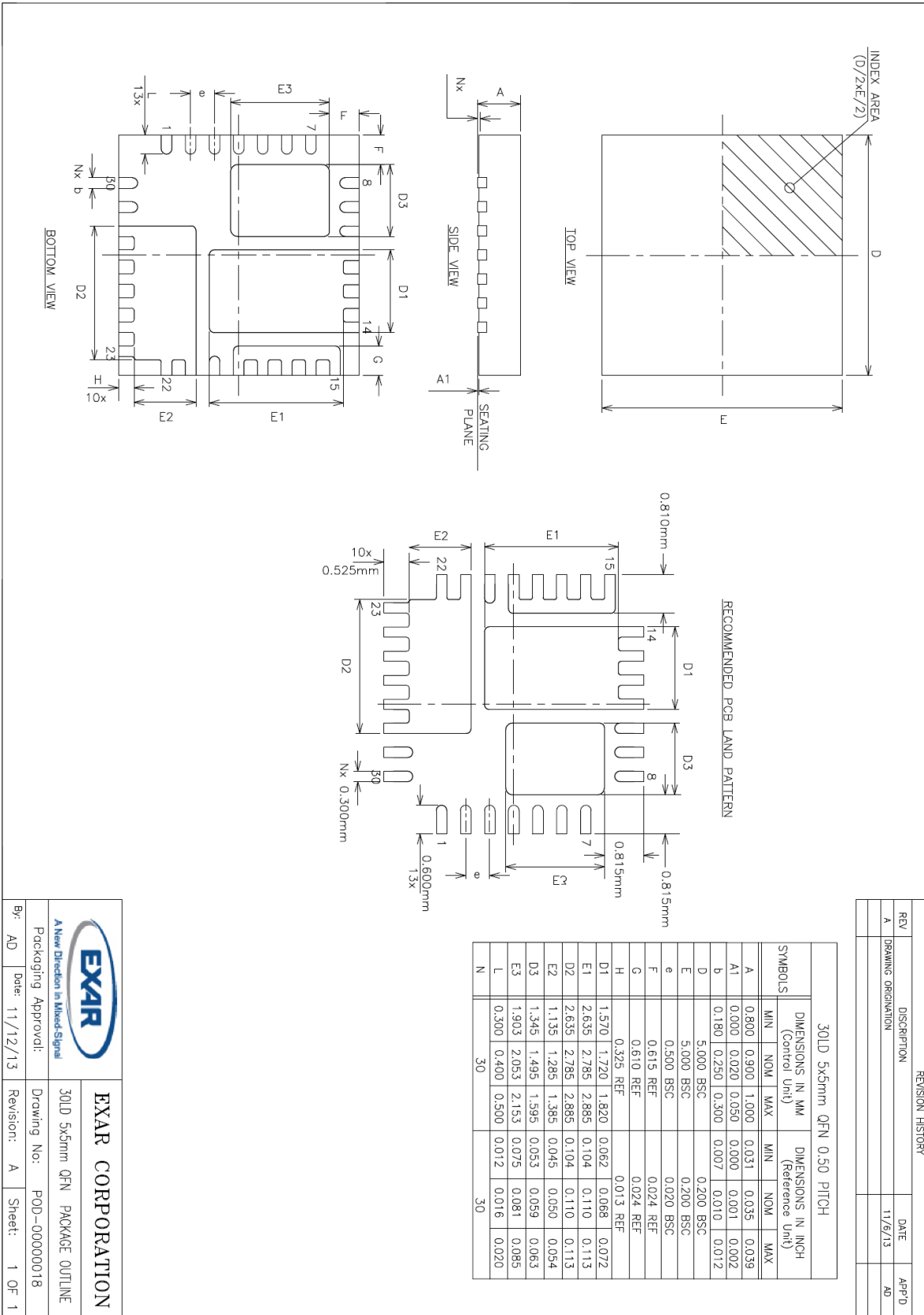

		<b>EXAR CORPORATION</b>	
A New Direction in Mixed Signal		30LD 5x5mm QFN PACKAGE OUTLINE	
By: AD	Date: 11/12/13	Drawing No: POD-00000018	Revision: A
Packaging Approval:		Sheet: 1 OF 1	

REVISION HISTORY		DATE	APP'D
REV	DESCRIPTION	11/5/13	AD
A	DRAWING ORIGINATION		



## Ordering Information

Part Number	Package	JEDEC Compliant	Operating Temperature Range	Packaging	Marking
XR76208EL-F	5x5mm QFN	Yes	-40°C to +125°C	Tray	76208E YYWWF XXXXXX
XR76208ELTR-F				Tape and Reel	
XR76208ELMTR-F				Mini Tape and Reel	
XR76208EVB	XR76208 Evaluation Board				
XR76205EL-F	5x5mm QFN	Yes	-40°C to +125°C	Tray	76205E YYWWF XXXXXX
XR76205ELTR-F				Tape and Reel	
XR76205ELMTR-F				Mini Tape and Reel	
XR76205EVB	XR76205 Evaluation Board				
XR76203EL-F	5x5mm QFN	Yes	-40°C to +125°C	Tray	76203E YYWWF XXXXXX
XR76203ELTR-F				Tape and Reel	
XR76203ELMTR-F				Mini Tape and Reel	
XR76203EVB	XR76203 Evaluation Board				

“YY” = Year (last two digits)- “WW” = Work Week- “X” = Lot Number; when applicable

## Revision History

Revision	Date	Description
1A	February 2015	ECN: 1509-04 Feb 2015

For Further Assistance:

**Technical Support:** [techsupport.exar.com](mailto:techsupport.exar.com)

**Technical Documentation:** [www.exar.com/techdoc](http://www.exar.com/techdoc)

**Exar Corporation Headquarters and Sales Offices**

48720 Kato Road Tel.: +1 (510) 668-7000  
Fremont, CA 95438 - USA Fax: +1 (510) 668-7001



## NOTICE

EXAR Corporation reserves the right to make changes to the products contained in this publication in order to improve design, performance or reliability. EXAR Corporation assumes no responsibility for the use of any circuits described herein, conveys no license under any patent or other right, and makes no representation that the circuits are free of patent infringement. Charts and schedules contained herein are only for illustration purposes and may vary depending upon a user's specific application. While the information in this publication has been carefully checked; no responsibility, however, is assumed for inaccuracies.

EXAR Corporation does not recommend the use of any of its products in life support applications where the failure or malfunction of the product can reasonably be expected to cause failure of the life support system or to significantly affect its safety or effectiveness. Products are not authorized for use in such applications unless EXAR Corporation receives, in writing, assurances to its satisfaction that: (a) the risk of injury or damage has been minimized; (b) the user assumes all such risks; (c) potential liability of EXAR Corporation is adequately protected under the circumstances.

Reproduction, in part or whole, without the prior written consent of EXAR Corporation is prohibited.