



Chipsmall Limited consists of a professional team with an average of over 10 year of expertise in the distribution of electronic components. Based in Hongkong, we have already established firm and mutual-benefit business relationships with customers from,Europe,America and south Asia,supplying obsolete and hard-to-find components to meet their specific needs.

With the principle of “Quality Parts,Customers Priority,Honest Operation,and Considerate Service”,our business mainly focus on the distribution of electronic components. Line cards we deal with include Microchip,ALPS,ROHM,Xilinx,Pulse,ON,Everlight and Freescale. Main products comprise IC,Modules,Potentiometer,IC Socket,Relay,Connector.Our parts cover such applications as commercial,industrial, and automotives areas.

We are looking forward to setting up business relationship with you and hope to provide you with the best service and solution. Let us make a better world for our industry!



Contact us

Tel: +86-755-8981 8866 Fax: +86-755-8427 6832

Email & Skype: info@chipsmall.com Web: www.chipsmall.com

Address: A1208, Overseas Decoration Building, #122 Zhenhua RD., Futian, Shenzhen, China



FEATURES

- 10-Bit Resolution
- 8-Channel Mux
- Sampling Rate - < 1kHz - 2MHz
- Low Power CMOS - 35 mW (typ)
- Power Down; Lower Consumption - 0.8 mW (typ)
- Input Range between GND and V_{DD}
- No S/H Required for Analog Signals less than 100kHz
- No S/H Required for CCD Signals less than 2MHz
- Single Power Supply (4.5 to 5.5V)
- Latch-Up Free
- ESD Protection: 2000 Volts Minimum

APPLICATIONS

- μ P/DSP Interface and Control Application
- High Resolution Imaging - Scanners & Copiers
- Wireless Digital Communications
- Multiplexed Data Acquisition

BENEFITS

- Reduced Board Space (Small Package)
- Reduced External Parts, No Sample/Hold Needed
- Suitable for Battery & Power Critical Applications
- Designer can Adapt Input Range & Scaling

GENERAL DESCRIPTION

The XRD8799 is a flexible, easy to use, precision 10-bit analog-to-digital converter with 8-channel mux that operates over a wide range of input and sampling conditions. The XRD8799 can operate with pulsed "on demand" conversion operation or continuous "pipeline" operation for sampling rates up to 2MHz. The elimination of the S/H requirements, very low power, and small package size offer the designer a low cost solution. No sample and hold is required for CCD applications up to 2MHz, or multiplexed input applications when the signal source bandwidth is limited to 100kHz. The input architecture of the XRD8799 allows direct interface to any analog input range between AGND and AV_{DD} (0 to 1V, 1 to 4V, 0 to 5V, etc.). The user simply sets $V_{REF(+)}$ and $V_{REF(-)}$ to encompass the desired input range.

Scaled reference resistor taps @ 1/4 R, 1/2 R and 3/4 R allow for customizing the transfer curve as well as providing a 1/2 span reference voltage. Digital outputs are CMOS and TTL compatible.

The XRD8799 uses a two-step flash technique. The first segment converts the 5 MSBs and consists of autobalanced comparators, latches, an encoder, and buffer storage registers. The second segment converts the remaining 5 LSBs.

When the power down input is "high", the data outputs DB9 to DB0 hold the current values and $V_{REF(-)}$ is disconnected from $V_{REF1(-)}$. The power consumption during the power down mode is 0.1mW.

ORDERING INFORMATION

PART NUMBER	PACKAGE	OPERATING TEMPERATURE RANGE
XRD8799AIQ	PQFP	-40°C to +85°C

FIGURE 1. SIMPLIFIED BLOCK DIAGRAM AND TIMING

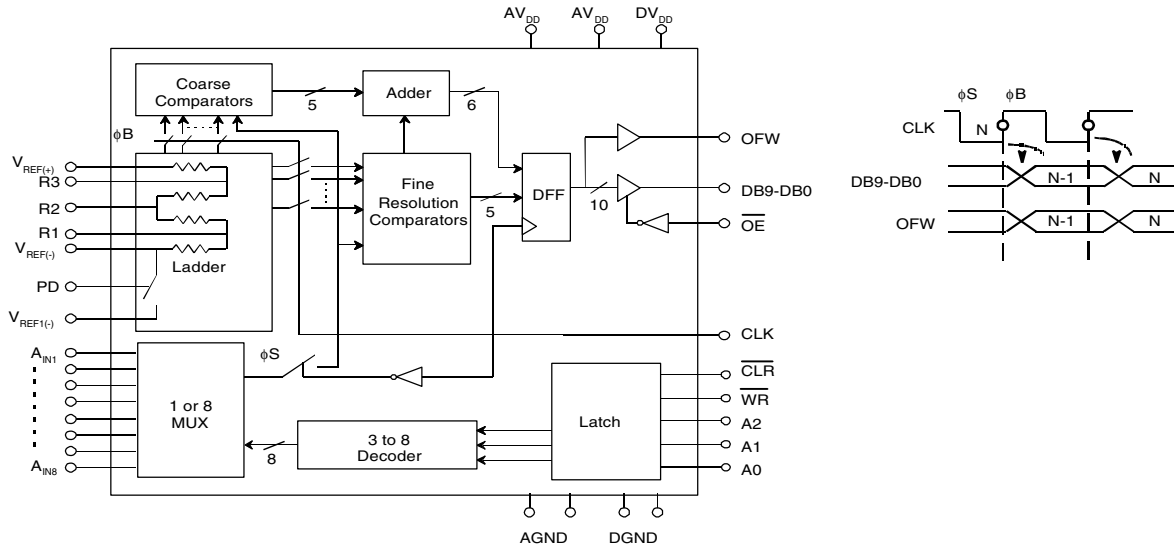
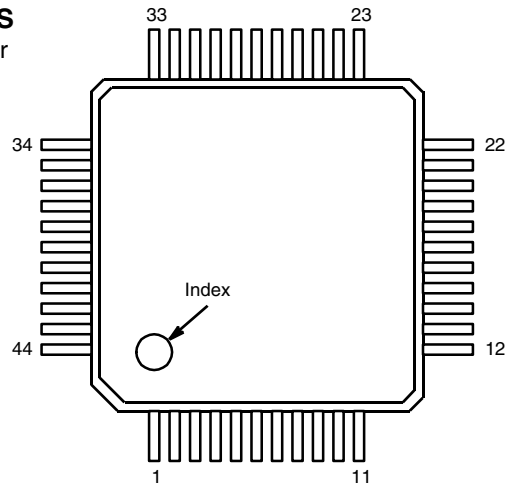

FIGURE 2. PIN OUT OF THE XRD8799

PIN CONFIGURATIONS

See Packaging Section for Package Dimensions



44-Pin PQFP (10mm x 10mm)

PIN DESCRIPTIONS

PIN #	NAME	DESCRIPTION
1	DB6	Data Output Bit 6
2	DB7	Data Output Bit 7
3	DGND	Digital Ground
4	DGND	Digital Ground
5	DV _{DD}	Digital V _{DD}
6	$\overline{\text{CLR}}$	Clear (Active Low)
7	$\overline{\text{WR}}$	Write (Active Low)
8	A2	Address 2
9	A1	Address 1
10	A0	Address 0
11	CLK	Clock Input
12	$\overline{\text{OE}}$	Output Enable (Active Low)
13	N/C	No Connect
14	DB8	Data Output Bit 8
15	DB9	Data Output Bit 9 (MSB)
16	OFW	Overflow Output
17	V _{REF(+)}	Upper Reference Voltage
18	V _{REF(-)}	Lower Reference Voltage
19	V _{REF1(-)}	Lower Reference Voltage
20	R1	Reference Ladder Tap
21	R2	Reference Ladder Tap
22	A _{IN8}	Analog Signal Input 8

PIN #	NAME	DESCRIPTION
23	R3	Reference Ladder Tap
24	N/C	No Connect
25	A _{IN1}	Analog Signal Input 1
26	A _{IN2}	Analog Signal Input 2
27	A _{IN3}	Analog Signal Input 3
28	A _{IN4}	Analog Signal Input 4
29	A _{IN5}	Analog Signal Input 5
30	AGND	Analog Ground
31	AV _{DD}	Analog V _{DD}
32	AV _{DD}	Analog V _{DD}
33	A _{IN6}	Analog Signal Input 6
34	AGND	Analog Ground
35	PD	Power Down
36	A _{IN7}	Analog Signal Input 7
37	DB0	Data Output Bit 0 (LSB)
38	DB1	Data Output Bit 1
39	DB2	Data Output Bit 2
40	DB3	Data Output Bit 3
41	DB4	Data Output Bit 4
42	DB5	Data Output Bit 5
43	N/C	No Connect
44	N/C	No Connect

TABLE 1: TRUTH TABLE FOR INPUT CHANNEL SELECTION

$\overline{\text{CLR}}$	$\overline{\text{WR}}$	A2	A1	A0	SELECTED ANALOG INPUT
L	X	X	X	X	$A_{\text{IN}1}$
H	L	L	L	L	$A_{\text{IN}1}$
H	L	L	L	H	$A_{\text{IN}2}$
H	L	L	H	L	$A_{\text{IN}3}$
H	L	L	H	H	$A_{\text{IN}4}$
H	L	H	L	L	$A_{\text{IN}5}$
H	L	H	L	H	$A_{\text{IN}6}$
H	L	H	H	L	$A_{\text{IN}7}$
H	L	H	H	H	$A_{\text{IN}8}$
H	H	X	X	X	Previous Selection

NOTE: $\overline{\text{CLR}}$, $\overline{\text{WR}}$, A2, A1, A0 are internally connected to ground through 500k Ω resistance.

ELECTRICAL CHARACTERISTICS

ELECTRICAL CHARACTERISTICS $V_{DD} = DV_{DD} = 5\text{ V}$, $F_S = 2\text{ MHz}$ (50% DUTY CYCLE), $V_{REF(+)} = 4.6$, $V_{REF(-)} = \text{AGND}$, $T_A = 25^\circ\text{C}$, UNLESS OTHERWISE SPECIFIED

PARAMETER	SYMBOL	MIN	TYP	MAX	UNITS	TEST CONDITIONS/COMMENTS
KEY FEATURES						
Resolution				10	Bits	
Sampling Rate	FS	.001		2.0	MHz	For Rated Performance
ACCURACY (A GRADE)²						
Differential Non-Linearity	DNL	-1	± 0.3	1	LSB	
Integral Non-Linearity	INL		1	2	LSB	Best Fit Line (Max INL - Min INL)/2
Zero Scale Error	EZS	0	50	100	mV	
Full Scale Error	EFS	0	30	60	mV	
REFERENCE VOLTAGES						
Positive Ref. Voltage ⁵	$V_{REF(+)}$	1.0	4.0	AV_{DD}	V	
Negative Ref. Voltage ⁵	$V_{REF(-)}$	AGND	1.0	$AV_{DD} - 1$	V	
Differential Ref. Voltage ⁵	V_{REF}	1.0	3.0	AV_{DD}	V	
Ladder Resistance	RL	500	1200	2000	Ω	
ANALOG INPUT¹						
Input Bandwidth (-1dB)		1.0		4.0	MHz	1-Channel
Input Bandwidth (-1dB)		.125		0.5	MHz	8-Channel
Input Voltage Range ⁷	V_{IN}	$V_{REF(-)}$		$V_{REF(+)}$	V	
Input Capacitance ³	C_{IN}		20		pF	
Aperture Delay ¹	t_{AP}		8		ns	
DIGITAL INPUTS						
Logical "1" Voltage	V_{IH}	2.0			V	
Logical "0" Voltage	V_{IL}			0.8	V	
Leakage Currents	I_{IN}					$V_{IN} = \text{DGND to } DV_{DD}$
CLK		-1		1	μA	
$\overline{\text{CLR}}$, $\overline{\text{WR}}$, A2, A1, A0, PD, $\overline{\text{OE}}$		-5		30	μA	These input pins have 500k Ω internal resistors to GND
Input Capacitance			5		pF	

ELECTRICAL CHARACTERISTICS $AV_{DD} = DV_{DD} = 5\text{ V}$, $F_S = 2\text{ MHz}$ (50% DUTY CYCLE), $V_{REF(+)} = 4.6$, $V_{REF(-)} = \text{AGND}$, $T_A = 25^\circ\text{C}$, UNLESS OTHERWISE SPECIFIED

PARAMETER	SYMBOL	MIN	TYP	MAX	UNITS	TEST CONDITIONS/COMMENTS
Clock Timing						
Clock Period	T_S	500		1,000,000	ns	
Rise & Fall Time ⁴	t_R, t_F			10	ns	
"High" Time	t_B	125	250	500,000	ns	
"Low" Time	t_S	125	250	500,000	ns	
DIGITAL OUTPUTS						$C_{OUT}=15\text{ pF}$
Logical "1" Voltage	V_{OH}	$DV_{DD}-0.5$			V	$I_{LOAD} = 4\text{ mA}$
Logical "0" Voltage	V_{OL}			0.4	V	$I_{LOAD} = 4\text{ mA}$
Tristate Leakage	I_{OZ}	-1		1	μA	$V_{OUT} = 0\text{ to }DV_{DD}$
Data Hold Time ¹	t_{HLD}		12		ns	
Data Valid Delay ¹	t_{DL}		30	35	ns	
Write Pulse Width ¹	t_{WR}	40			ns	
Multiplexer Address Setup Time ¹	t_{AS}	80			ns	
Multiplexer Address Hold Time ¹	t_{AH}	0			ns	
Delay from \overline{WR} to Multiplexer ¹						
Enable	t_{MUXEN1}			80	ns	
Clock to PD Setup Time	t_{CLKS1}			400	ns	
Clock to UR Setup Time	t_{CLKS2}	0			ns	
Clock to PD Hold Time	t_{CLKH1}			600	ns	

LOW POWER, 2 MSPS, 10-BIT, A/D CONVERTER WITH 8-CHANNEL MUX

REV. 1.00

ELECTRICAL CHARACTERISTICS $AV_{DD} = DV_{DD} = 5\text{ V}$, $F_S = 2\text{ MHz}$ (50% DUTY CYCLE), $V_{REF(+)} = 4.6$, $V_{REF(-)} = \text{AGND}$, $T_A = 25^\circ\text{C}$, UNLESS OTHERWISE SPECIFIED

PARAMETER	SYMBOL	MIN	TYP	MAX	UNITS	TEST CONDITIONS/COMMENTS
Clock to $\overline{\text{WR}}$ Hold Time	t_{CLKH2}	0			ns	
Power Down Time ¹	t_{PD}			300	ns	
Power Up Time ¹	t_{PU}			200	ns	
Data Enable Delay	t_{DEN}		14	16	ns	
Data High Z Delay	t_{DHz}		4	6	ns	
Pipeline Delay (Latency)			1.5		cycles	
POWER SUPPLIES ⁸						
Power Down (I_{DD})	$I_{\text{PD-DD}}$		0.01	0.10	mA	PD=High, CLK High or Low
Operating Voltage (AV_{DD} , DV_{DD})	V_{DD}	4.5	5.0	5.5	V	
Current ($AV_{\text{DD}} + DV_{\text{DD}}$)	I_{DD}		7	10	mA	PD=Low (Normal Mode)

NOTES:

- 1 Guaranteed. Not tested.
- 2 Tester measures code transition voltages by dithering the voltage of the analog input (V_{IN}). The difference between the measured code width and the ideal value ($V_{\text{REF}}/1024$) is the DNL error. The INL error is the maximum distance (in LSBs) from the best fit line to any transition voltage.
- 3 See V_{IN} input equivalent circuit.
- 4 Clock specification to meet aperture specification (t_{AP}). Actual rise/fall time can be less stringent with no loss of accuracy.
- 5 Specified values guarantee functional device. Refer to other parameters for accuracy.
- 6 System can clock the XRD8799 with any duty cycle as long as all timing conditions are met.
- 7 Input range where input is converted correctly into binary code. Input voltage outside specified range converts to zero or full scale output.
- 8 DV_{DD} and AV_{DD} are connected through the silicon substrate. Connect together at the package.

SPECIFICATIONS ARE SUBJECT TO CHANGE WITHOUT NOTICE

ABSOLUTE MAXIMUM RATINGS: ($T_A = +25^\circ\text{C}$ UNLESS OTHERWISE NOTED)^{1, 2, 3}

V_{DD} (to GND)	+7 V
$V_{REF(+)}$, $V_{REF(-)}$, $V_{REF(-)}$	GND -0.5 to $V_{DD} + 0.5$ V
All A_{INs}	GND -0.5 to $V_{DD} + 0.5$ V
All Inputs	GND -0.5 to $V_{DD} + 0.5$ V
All Outputs	GND -0.5 to $V_{DD} + 0.5$ V
Storage Temperature	-65 to +150 °C
Lead Temperature (Soldering 10 seconds)	+300 °C
Package Power Dissipation Rating to 75 °C	
PQFP	450mW
Derates above 75 °C	14mW/°C

NOTE:

- 1 Stresses above those listed under "Absolute Maximum Ratings" may cause permanent damage to the device. This is a stress rating only and functional operation at or above this specification is not implied. Exposure to maximum rating conditions for extended periods may affect device reliability.
- 2 Any input pin which can see a value outside the absolute maximum ratings should be protected by Schottky diode clamps(HP5082-2835) from input pin to the supplies. All inputs have protection diodes which will protect the device from short transients outside the supplies of less than 100mA for less than 100µs.
- 3 V_{DD} refers to AV_{DD} and DV_{DD} . GND refers to AGND and DGND.

FIGURE 3. XRD8799 TIMING DIAGRAM

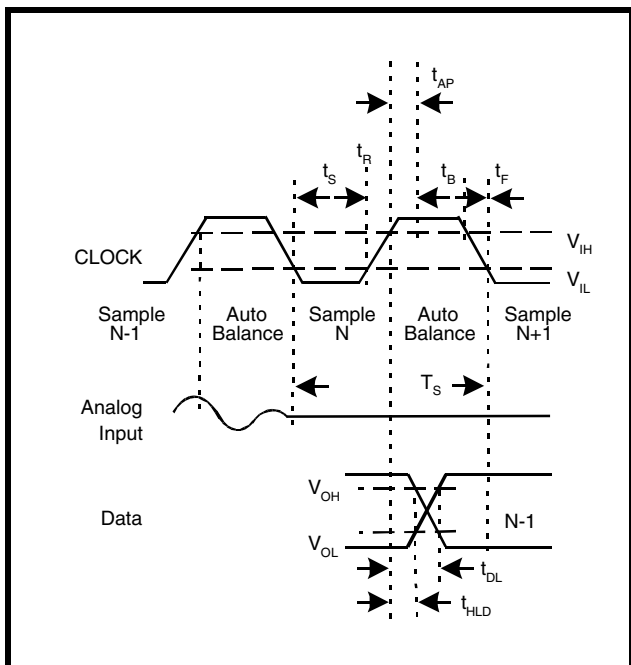

THEORY OF OPERATION

1.0 ANALOG-TO-DIGITAL CONVERSION

The XRD8799 converts analog voltages into 1024 digital codes by encoding the outputs of coarse and fine comparators. Digital logic is used to generate the overflow bit. The conversion is synchronous with the clock and it is accomplished in 2 clock periods.

The reference resistance ladder is a series of resistors. The fine comparators use a patented interpolation circuit to generate the equivalent of 1024 evenly spaced reference voltages between $V_{REF(-)}$ and $V_{REF(+)}$.

The clock signal generates the two internal phases, ϕ_B (CLK high) and ϕ_S (CLK low = sample) (See Figure 1). The rising edge of the CLK input marks the end of the sampling phase (ϕ_S). Internal delay of the clock circuitry will delay the actual instant when ϕ_S

disconnects the latches from the comparators. This delay is called aperture delay (t_{AP}).

The coarse comparators make the first pass conversion and selects a ladder range for the fine comparators. The fine comparators are connected to the selected range during the next ϕ_B phase.

FIGURE 4. XRD8799 COMPARATORS

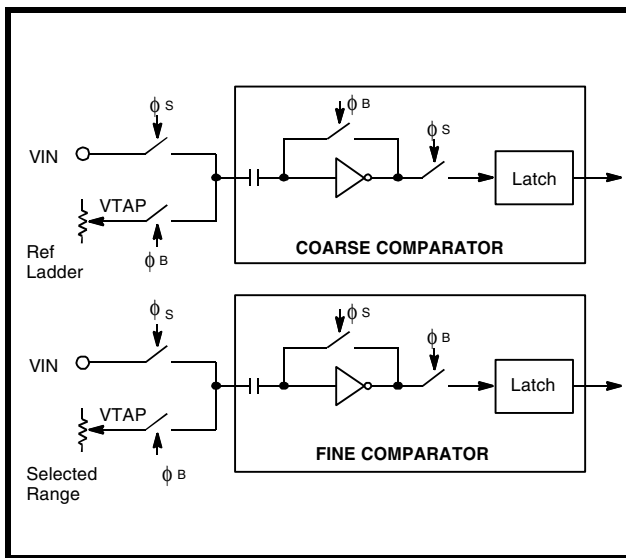

A_{IN} Sampling, Ladder Sampling, and Conversion Timing

Figure 3 shows this relationship as a timing chart. A_{IN} sampling, ladder sampling and output data relationships are shown for the general case where the levels which drive the ladder need to change for each sampled A_{IN} time point. The ladder is referenced for both last A_{IN} sample and next A_{IN} sample at the same time. If the ladder's levels change by more than 1 LSB, one of the samples must be discarded. Also note that the clock low period for the discarded A_{IN} can be reduced to the minimum t_S time.

FIGURE 5. XRD8799 COMPARATORS

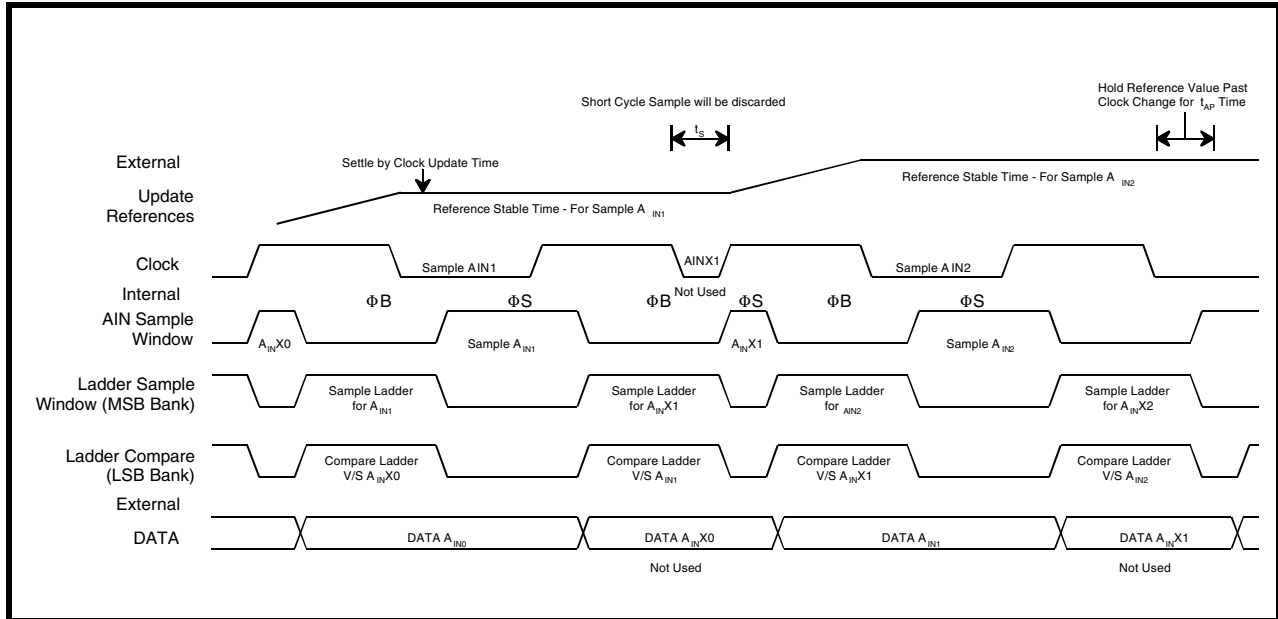

1.1 ACCURACY OF CONVERSION: DNL AND INL

The transfer function for an ideal A/D converter is shown in Figure 6.

FIGURE 6. IDEAL A/D TRANSFER FUNCTION

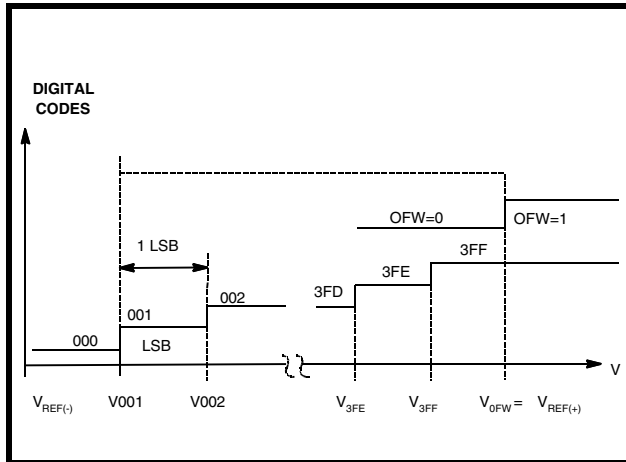

The overflow transition (VOFW) takes place at:

$$V_{IN} = V_{OFW} = V_{REF(+)}$$

The first and the last transitions for the data bits take place at:

$$V_{IN} = V_{001} = V_{REF(-)} + 1.0 * LSB$$

$$V_{IN} = V_{3FF} = V_{REF(-)} - 1.0 * LSB$$

$$V_{REF} = V_{REF(+)} - V_{REF(-)}$$

$$LSB = V_{REF} / 1024 = (V_{3FF} - V_{001}) / 1022$$

NOTE: The overflow transition is a flag and has no impact on the data bits.

In a "real" converter the code-to-code transitions don't fall exactly every V_{REF}/1024 volts.

A positive DNL (Differential Non-Linearity) error means that the real width of a particular code is larger than 1 LSB. This error is measured in fractions of LSBs.

A Max DNL specification guarantees that ALL code widths (DNL errors) are within the stated value. A specification of Max DNL = ± 0.5 LSB means that all code widths are within 0.5 and 1.5 LSB. If V_{REF} = 4.608 V then 1 LSB = 4.5 mV and every code width is within 2.25 and 6.75 mV.

FIGURE 7. DNL MEASUREMENT ON PRODUCTION TESTER

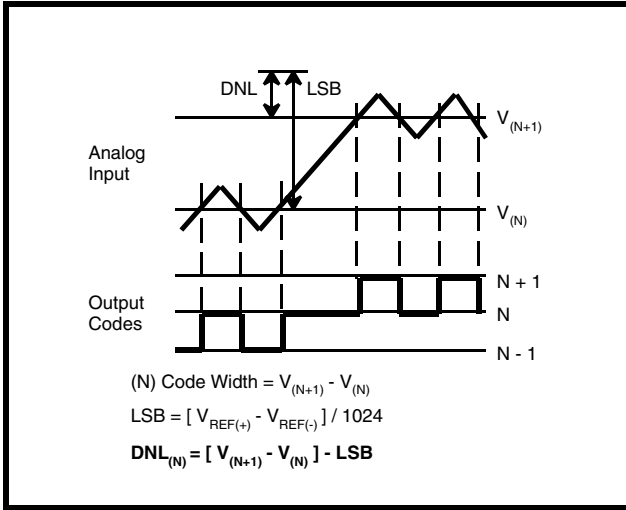

The formulas for Differential Non-Linearity (DNL), Integral Non-Linearity (INL) and zero and full scale errors (EZS, EFS) are:

$$DNL(001) = V002 - V001 - LSB$$

$$\vdots$$

$$DNL(3FE) = V3FF - V3FE - LSB$$

$$EFS \text{ (full scale error)} = V3FF - [V_{REF(+)} - 1.5 * LSB]$$

$$EZS \text{ (zero scale error)} = V001 - [V_{REF(-)} + 0.5 * LSB]$$

FIGURE 8. REAL A/D TRANSFER CURVE

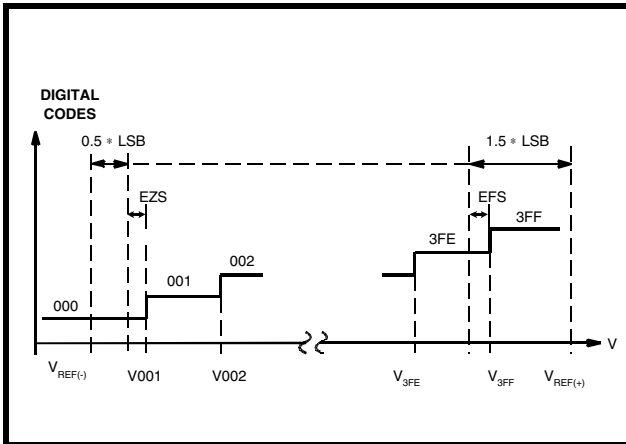
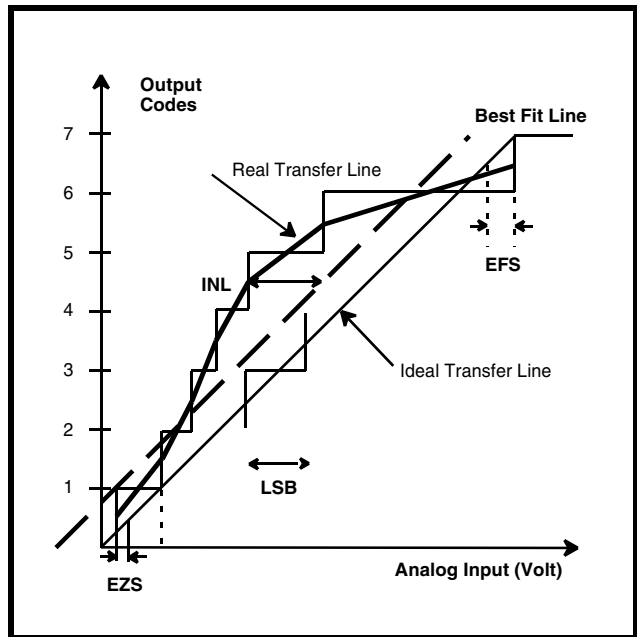

Figure 8 shows the zero scale and full scale error terms.

Figure 9 gives a visual definition of the INL error. The chart shows a 3-bit converter transfer curve with greatly exaggerated DNL errors to show the deviation of the real transfer curve from the ideal one.

After a tester has measured all the transition voltages, the computer draws a line parallel to the ideal transfer line. By definition the best fit line makes equal the positive and the negative INL errors. For example, an INL error of -1 to +2 LSB's relative to the Ideal Line would be ± 1.5 LSB's relative to the best fit line.

FIGURE 9. INL ERROR CALCULATION



1.2 CLOCK AND CONVERSION TIMING

A system will clock the XRD8799 continuously or it will give clock pulses intermittently when a conversion is desired. The timing of Figure 10a shows normal operation, while the timing of Figure 10b keeps the XRD8799 in balance and ready to sample the analog input.

FIGURE 10. RELATIONSHIP OF DATA TO CLOCK

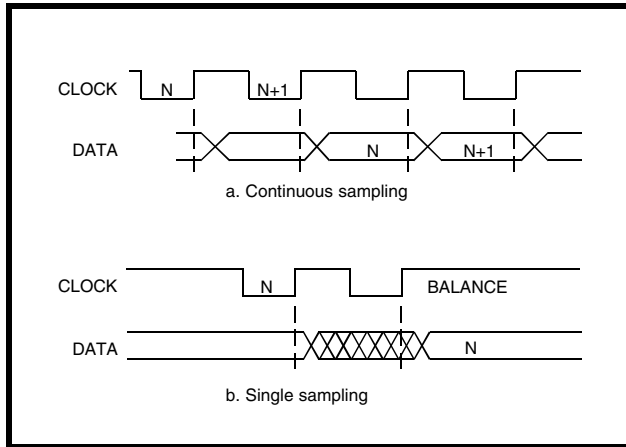

1.3 ANALOG INPUT

The XRD8799 has very flexible input range characteristics. The user may set $V_{REF(+)}$ and $V_{REF(-)}$ to two fixed voltages and then vary the input DC and AC levels to match the VREF range. Another method is to first design the analog input circuitry and then adjust the reference voltages for the analog input range.

One advantage is that this approach may eliminate the need for external gain and offset adjust circuitry which may be required by fixed input range A/Ds.

The XRD8799's performance is optimized by using analog input circuitry that is capable of driving the A_{IN} input. Figure 11 shows the equivalent circuit for A_{IN} .

FIGURE 11. ANALOG INPUT EQUIVALENT CIRCUIT

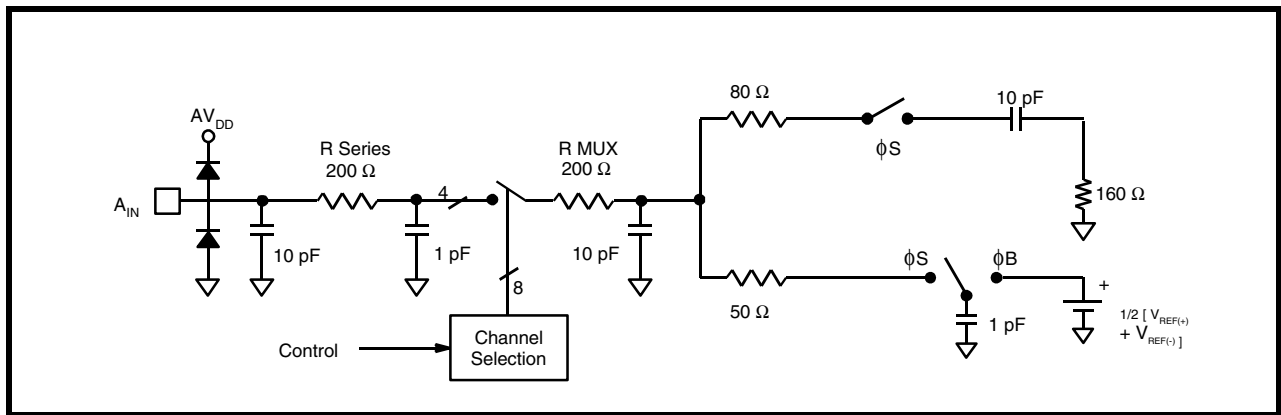
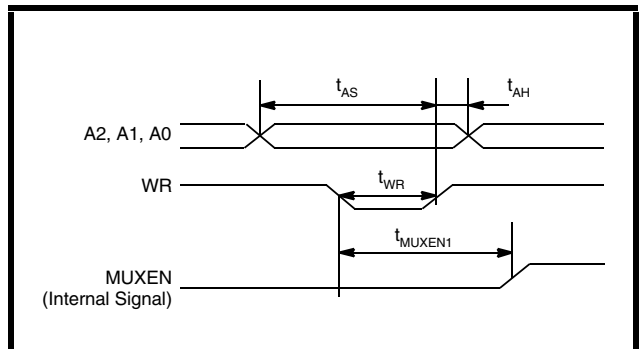
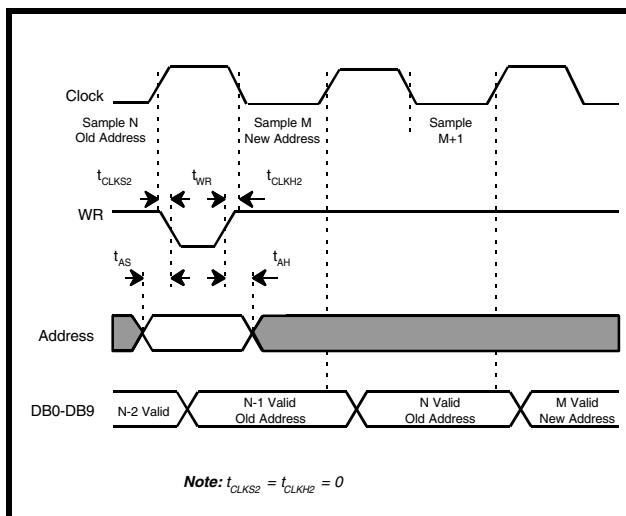

FIGURE 13. ANALOG MUX TIMING

1.4 ANALOG INPUT MULTIPLEXER

The XRD8799 includes a 8-Channel analog input multiplexer. The relationship between the clock, the multiplexer address, the WR and the output data is shown in Figure 12.

FIGURE 12. MUX ADDRESS TIMING



1.5 REFERENCE VOLTAGES

The input/output relationship is a function of V_{REF} :

$$A_{IN} = V_{IN} - V_{REF(-)}$$

$$V_{REF} = V_{REF(+)} - V_{REF(-)}$$

$$DATA = 1024 * (A_{IN}/V_{REF})$$

A system can increase total gain by reducing V_{REF}

1.6 DIGITAL INTERFACES

The logic encodes the outputs of the comparators into a binary code and latches the data in a D-type flip-flop for output.

The functional equivalent of the XRD8799 (Figure 14) is composed of:

1. Delay stage (t_{AP}) from the clock to the sampling phase (f_S).
2. An ideal analog switch which samples V_{IN} .
3. An ideal A/D which tracks and converts V_{IN} with no delay.
4. A series of two DFF's with specified hold (t_{HLD}) and delay (t_{DL}) times.

t_{AP} , t_{HLD} and t_{DL} are specified in the Electrical Characteristics table.

1.7 POWER DOWN

Figure 15 shows the relationship between the clock, sampled V_{IN} to output data relationship and the effect of power down.

FIGURE 14. XRD8799 FUNCTIONAL EQUIVALENT CIRCUIT AND INTERFACE TIMING

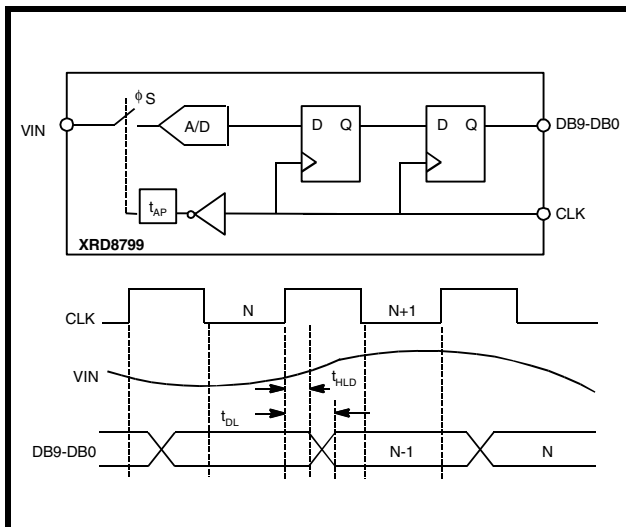
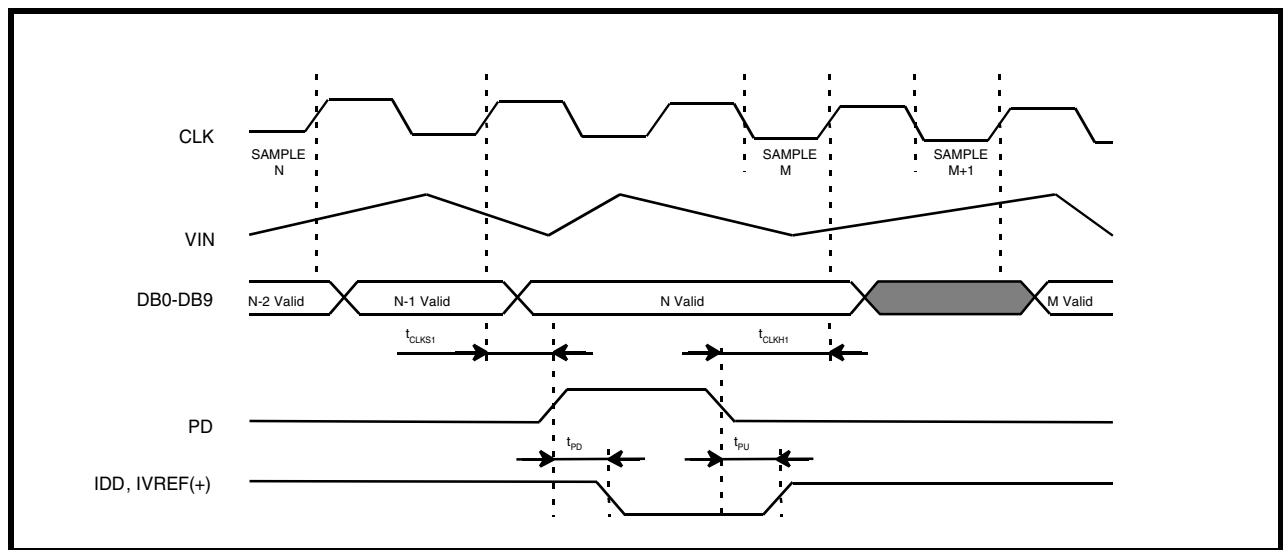
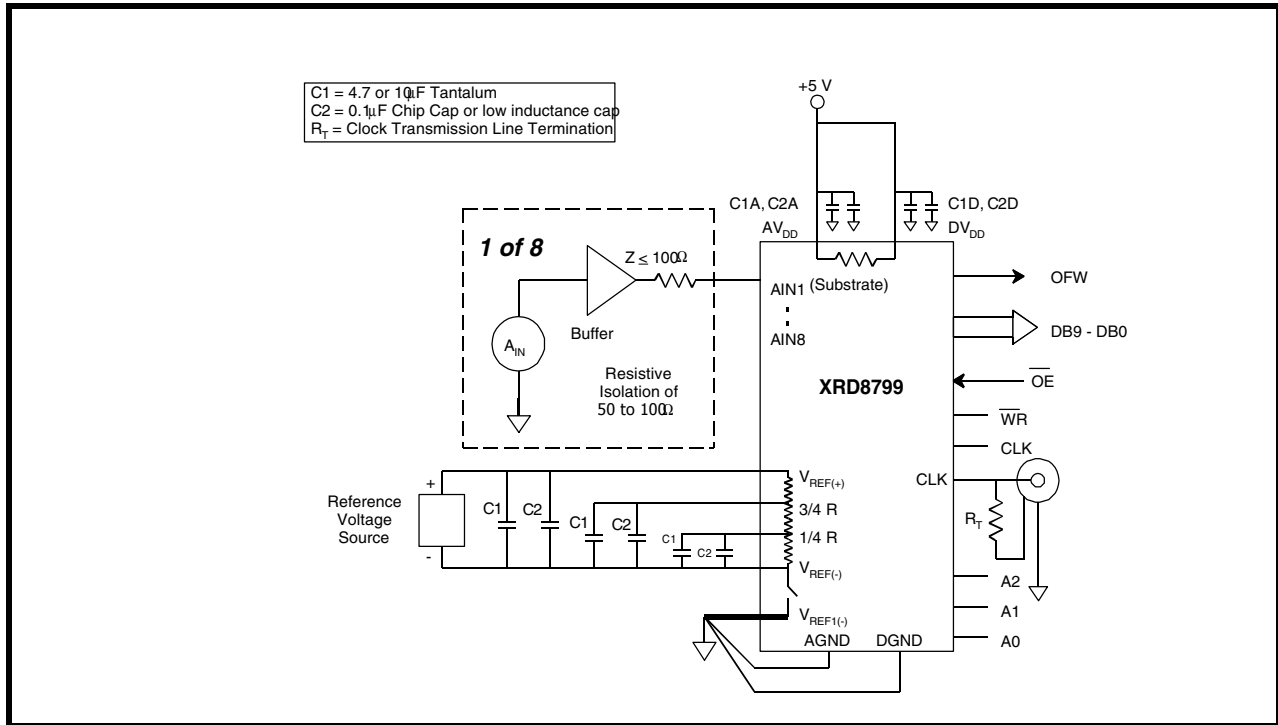

FIGURE 15. POWER DOWN TIMING DIAGRAM



2.0 APPLICATION NOTES

FIGURE 16. TYPICAL CIRCUIT CONNECTIONS



The following information will be useful in maximizing the performance of the XRD8799.

1. All signals should not exceed $AV_{DD} + 0.5\text{ V}$ or $AGND - 0.5\text{ V}$ or $DV_{DD} + 0.5\text{ V}$ or $DGND - 0.5\text{ V}$.
2. Any input pin which can see a value outside the absolute maximum ratings (AV_{DD} or $DV_{DD} + 0.5\text{ V}$ or $AGND - 0.5\text{ V}$) should be protected by diode clamps (HP5082-2835) from input pin to the supplies. All XRD8799 inputs have input protection diodes which will protect the device from short transients outside the supply ranges.
3. The design of a PC board will affect the accuracy of XRD8799. Use of wire wrap is not recommended.
4. The analog input signal (V_{IN}) is quite sensitive and should be properly routed and terminated. It should be shielded from the clock and digital outputs so as to minimize cross coupling and noise pickup.
5. The analog input should be driven by a low impedance (less than 50Ω).
6. Analog and digital ground planes should be substantial and common at one point only. The ground plane should act as a shield for parasitics and not a return path for signals. To reduce noise levels, use separate low impedance ground paths. *DGND should not be shared with other digital circuitry.* If separate low impedance paths cannot be provided, DGND should be connected to AGND next to the XRD8799.
7. DV_{DD} should not be shared with other digital circuitry to avoid conversion errors caused by digital supply transients. DV_{DD} for the XRD8799 should be connected to AV_{DD} next to the XRD8799.
8. DV_{DD} and AV_{DD} are connected inside the XRD8799. DGND and AGND are connected internally.
9. Each power supply and reference voltage pin should be decoupled with a ceramic ($0.1\mu\text{F}$) and a tantalum ($10\mu\text{F}$) capacitor as close to the device as possible.
10. The digital output should not drive long wires. The capacitive coupling and reflection will contribute noise to the conversion. When driving distant loads, buffers should be used. 100Ω resistors in series with the digital outputs in some applications reduces the digital output disruption of A_{IN} .

FIGURE 17. EXAMPLE OF A REFERENCE VOLTAGE SOURCE

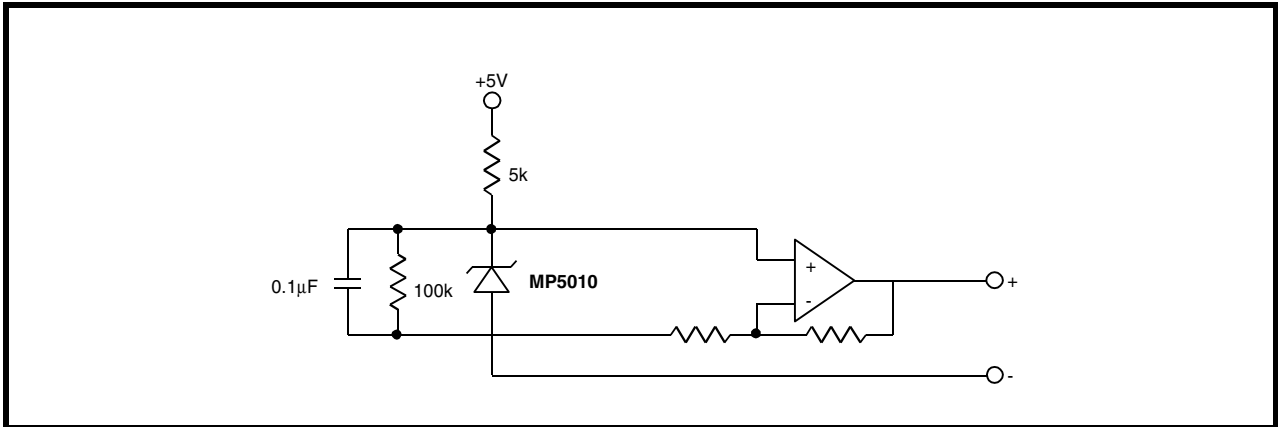
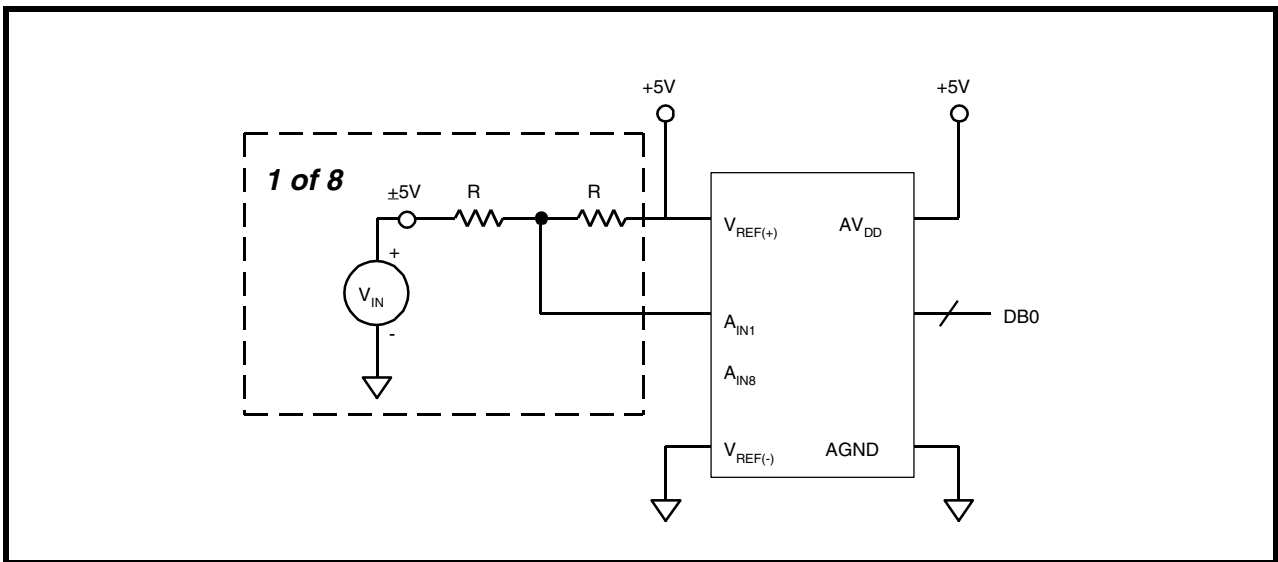

FIGURE 18. ±5V ANALOG INPUT



For $R = 5k$ use Beckman Instruments #694-3-R10k resistor array or equivalent.

NOTE: High R values affect the input BW of ADC due to the $(R * C_{IN})$ of ADC time constant. Therefore, for different applications the R value needs to be selected as a trade-off between A_{IN} settling time and power dissipation.

FIGURE 19. $\pm 10V$ ANALOG INPUT

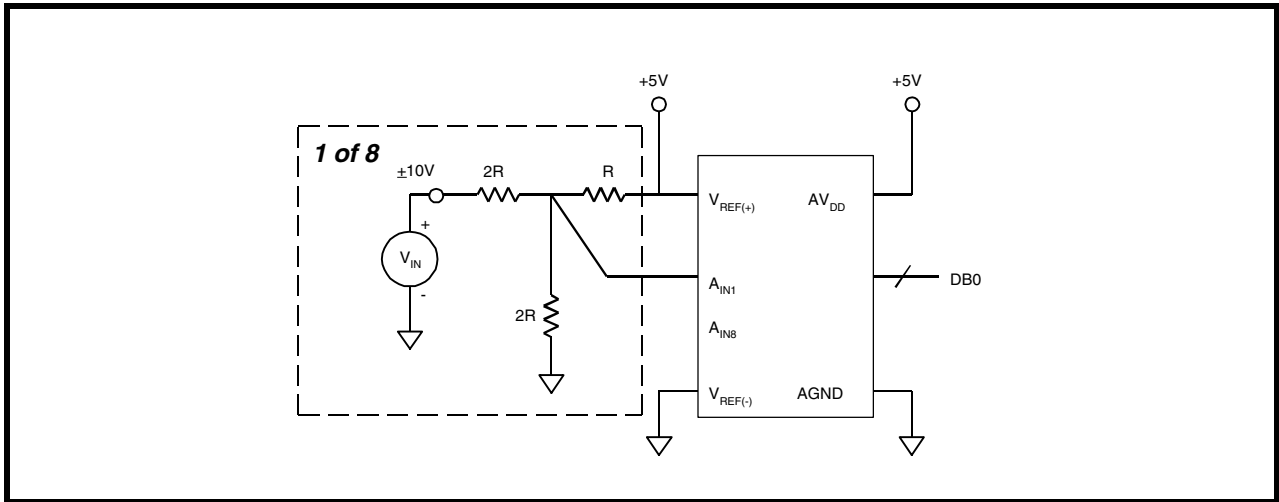

For $R = 5k$ use Beckman Instruments #694-3-R10k resistor array or equivalent.

NOTE: High R values affect the input BW of ADC due to the $(R * C_{IN}$ of ADC) time constant. Therefore, for different applications the R value needs to be selected as a trade-off between A_{IN} settling time and power dissipation.

FIGURE 20. A/D LADDER AND A_{IN} WITH PROGRAMMED CONTROL (OF $V_{REF(+)}$, $V_{REF(-)}$, 1/4 AND 3/4 TAP.)

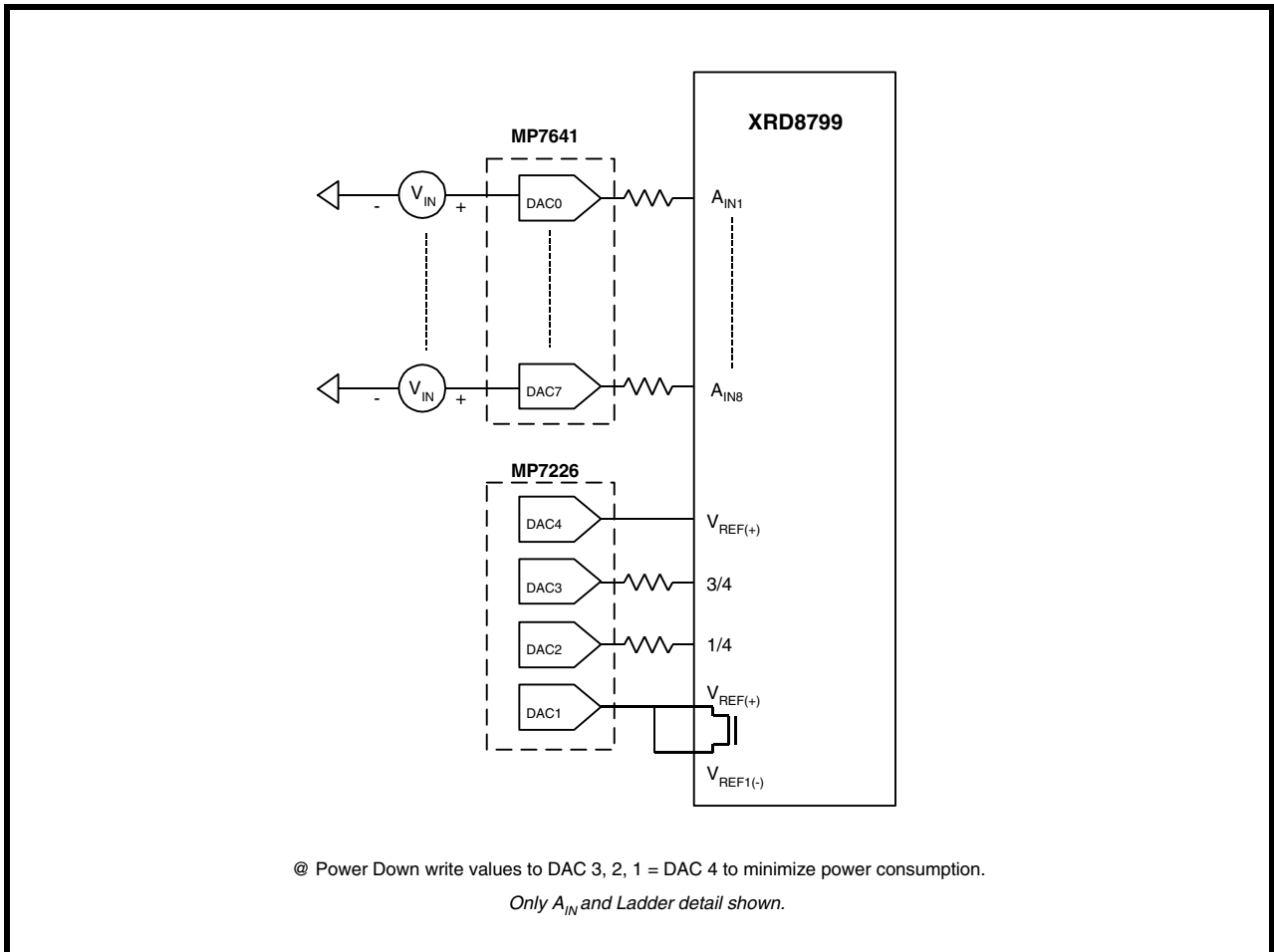

FIGURE 21. DNL vs. SAMPLING FREQUENCY

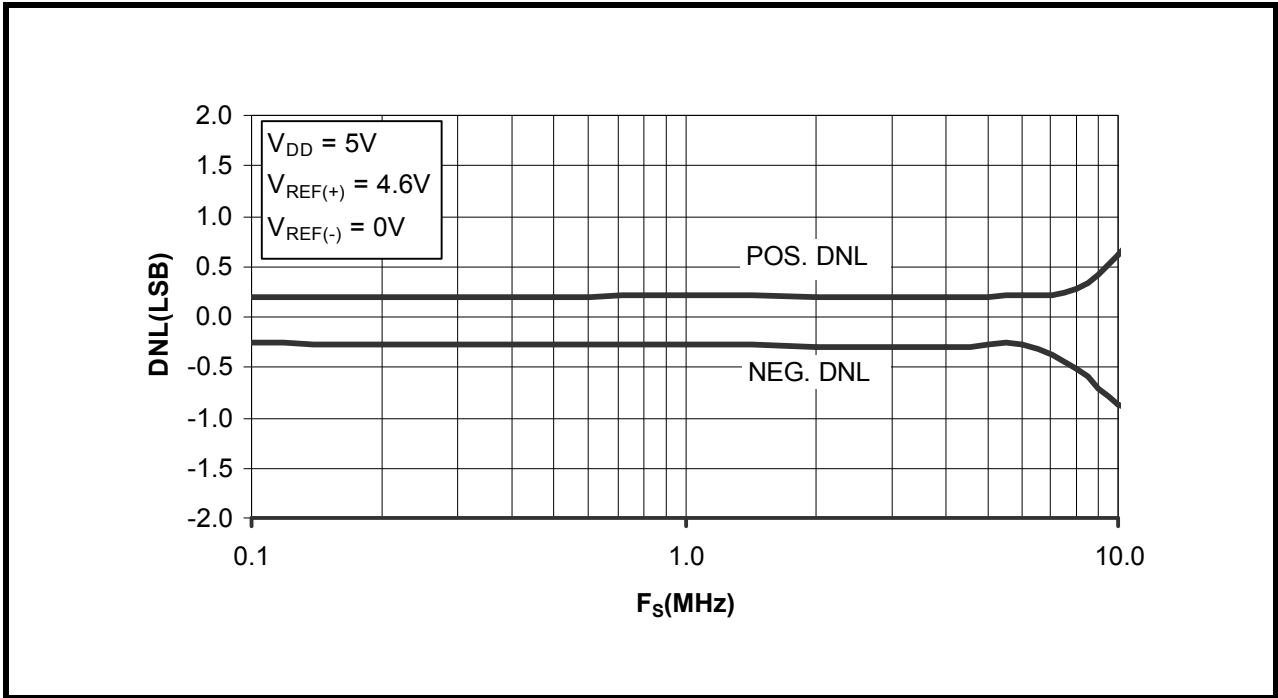

FIGURE 22. INL vs. SAMPLING FREQUENCY

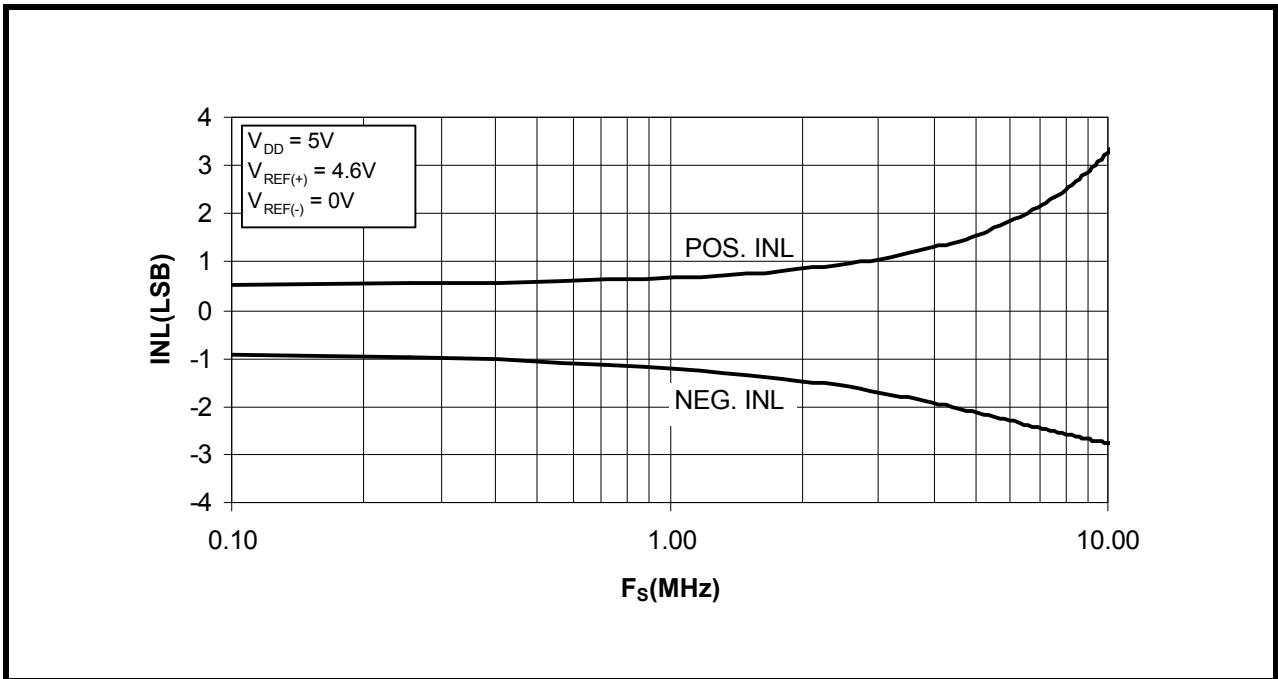

FIGURE 23. SUPPLY CURRENT VS. SAMPLING FREQUENCY

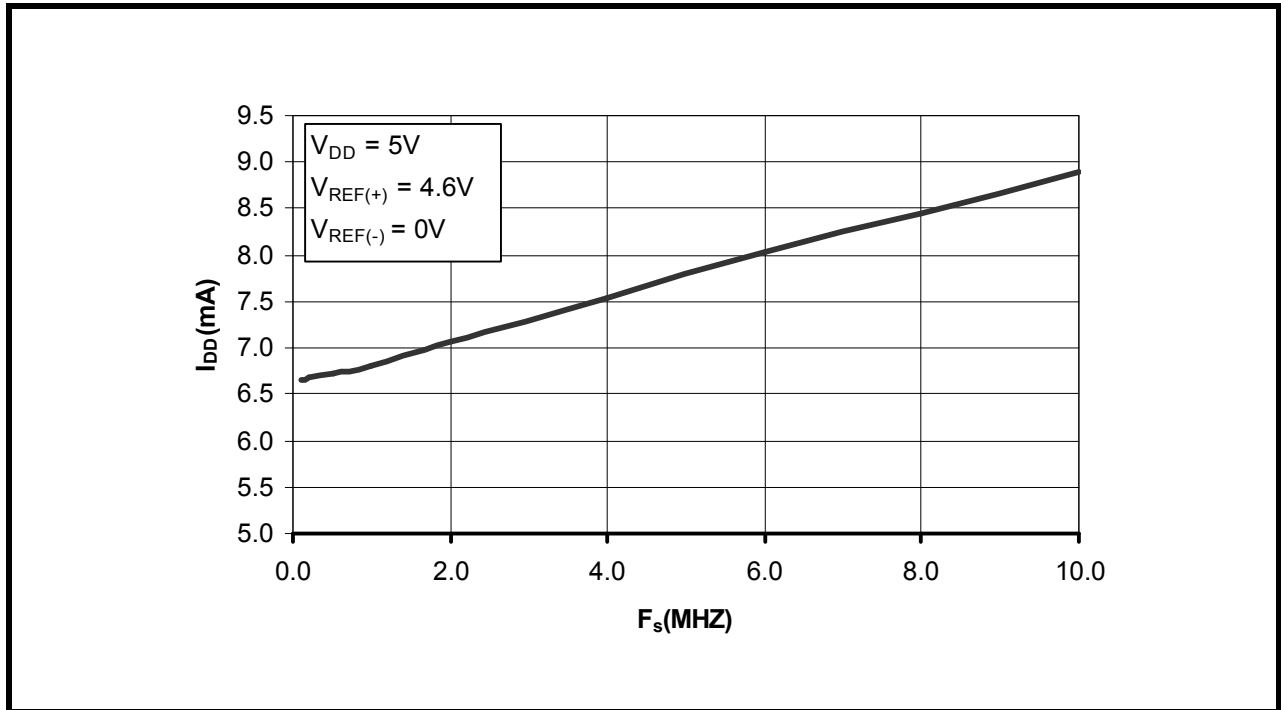

FIGURE 24. BEST FIT INL VS. REFERENCE VOLTAGE

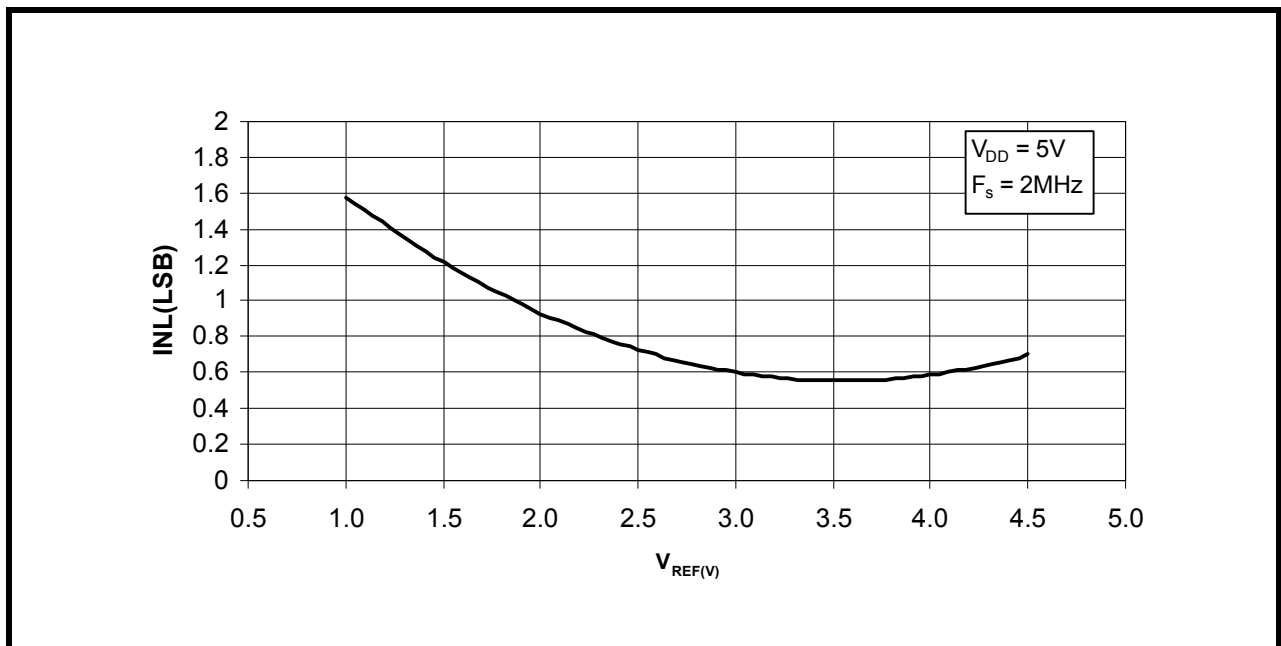

FIGURE 25. DNL VS. REFERENCE VOLTAGE

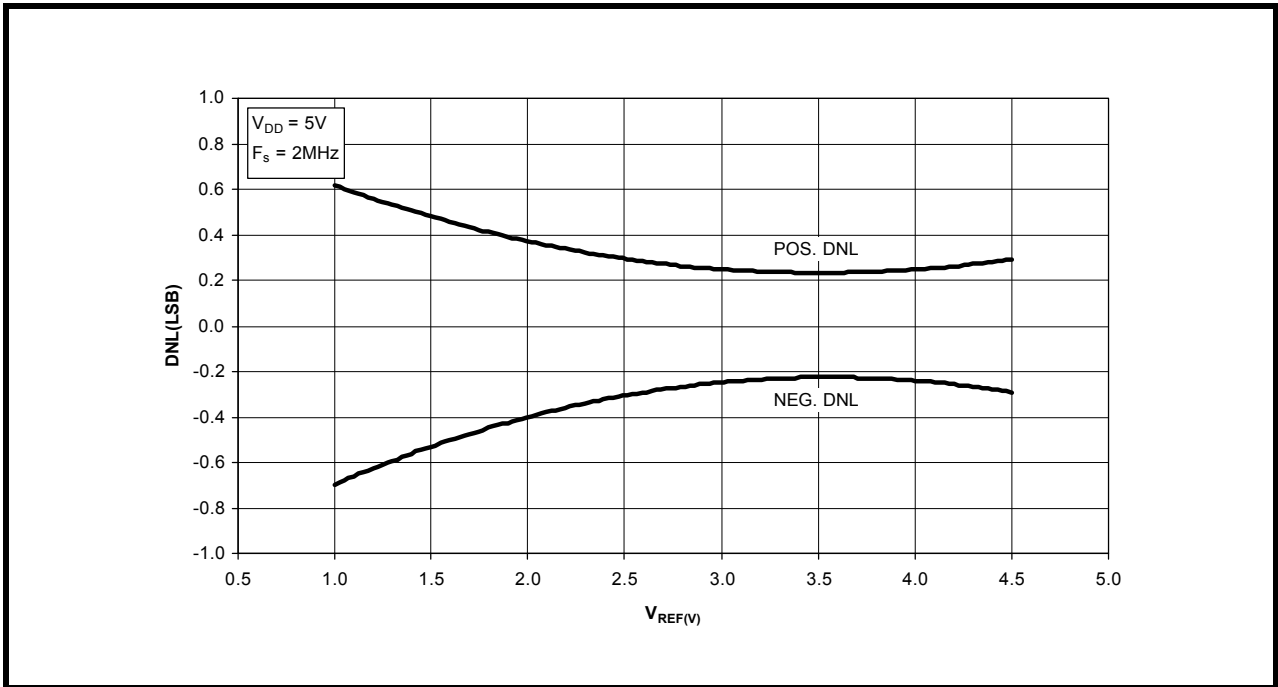

FIGURE 26. SUPPLY CURRENT VS. TEMPERATURE

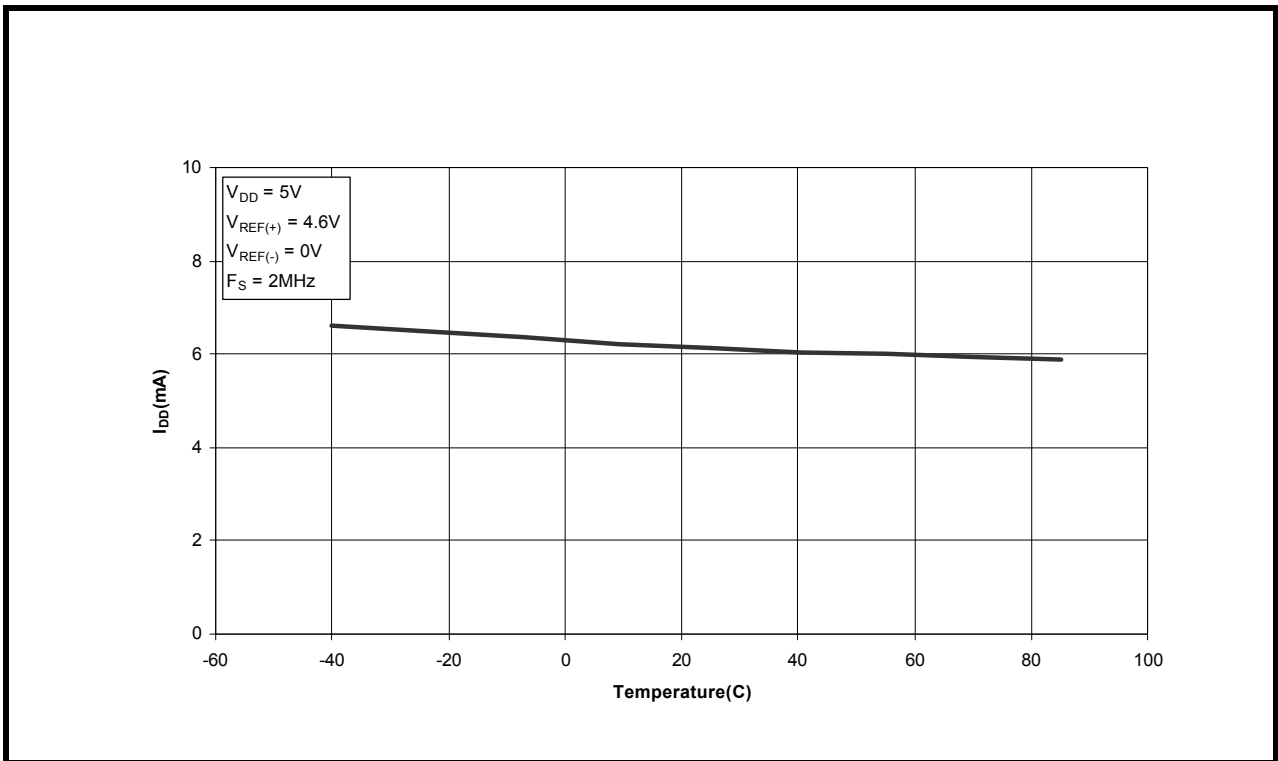

FIGURE 27. DNL VS. TEMPERATURE

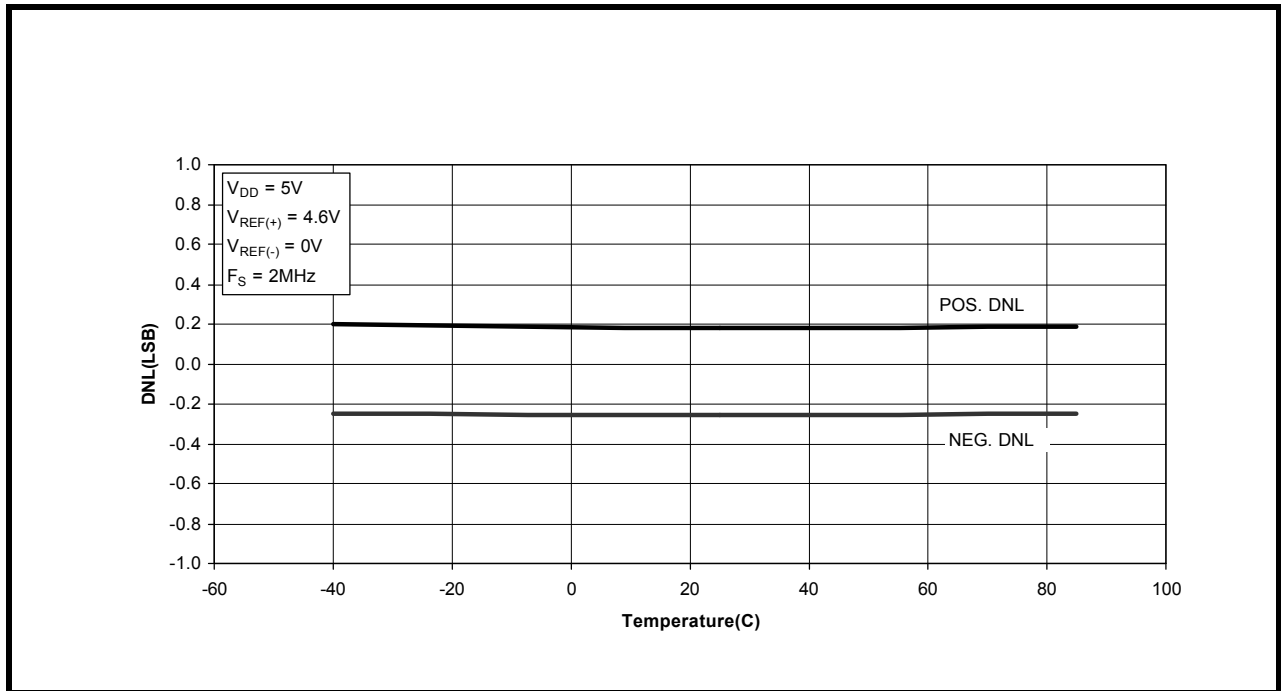

FIGURE 28. REFERENCE RESISTANCE VS. TEMPERATURE

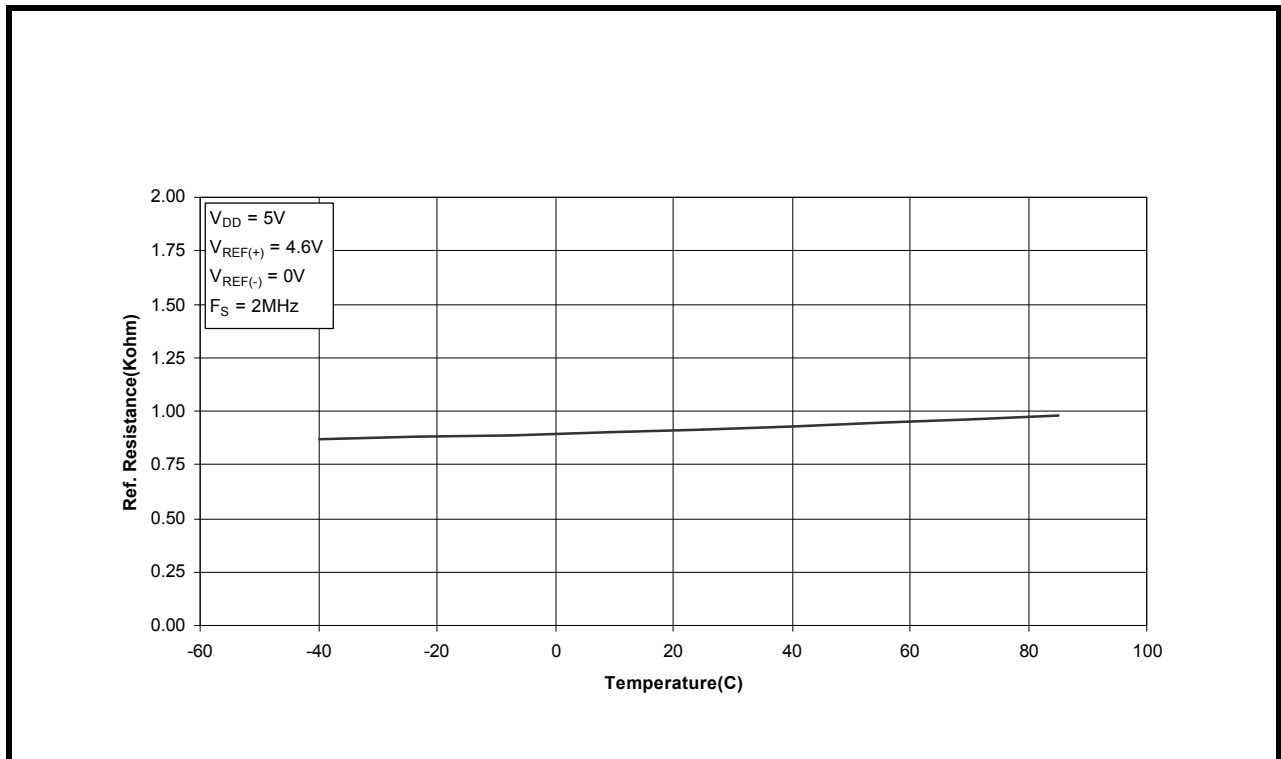
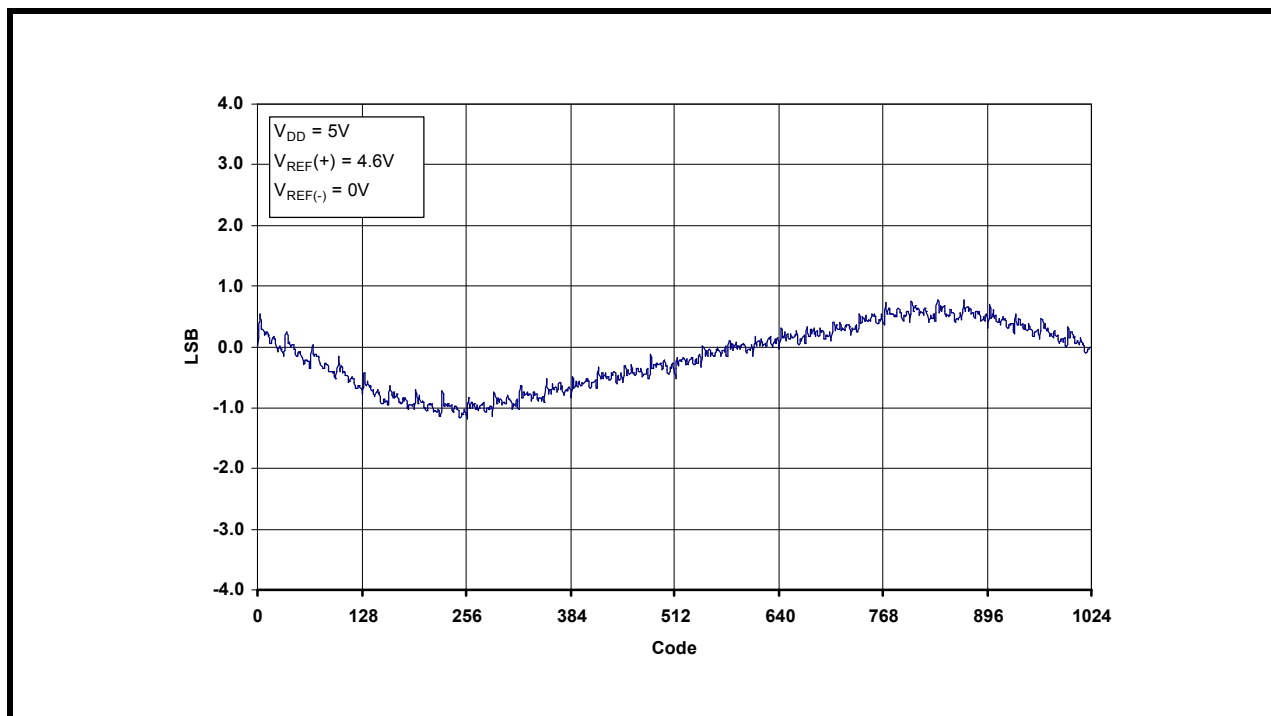

FIGURE 29. INL @ 2MSPS



44 LEAD PLASTIC QUAD FLAT PACK

(10 mm x 10 mm QFP, 1.60 mm Form)

REV. 2.00

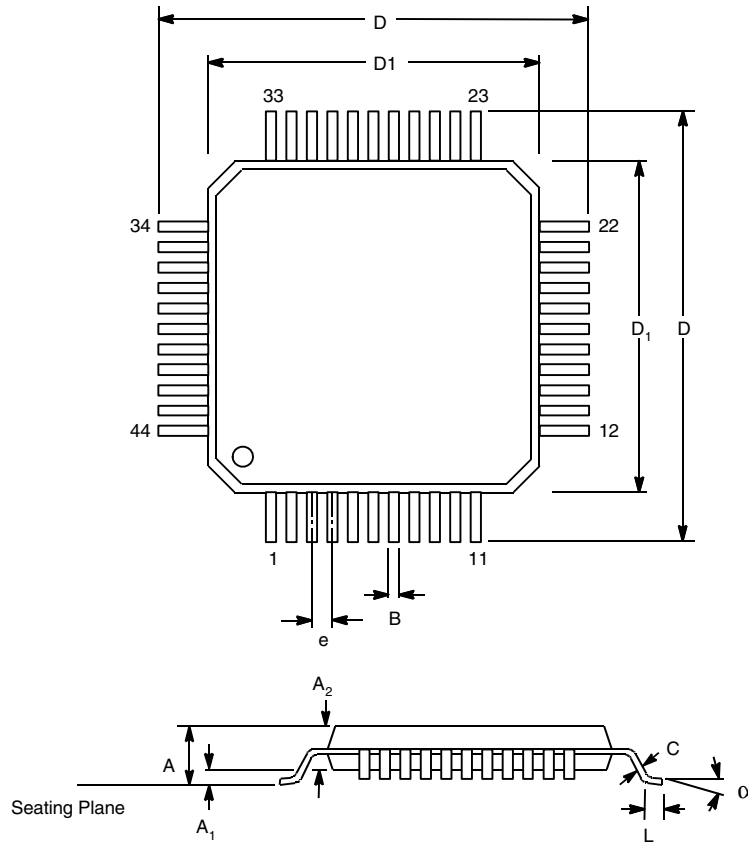

Note: The control dimension is the millimeter column

SYMBOL	INCHES		MILLIMETERS	
	MIN	MAX	MIN	MAX
A	0.072	0.093	1.82	2.45
A ₁	0.001	0.010	0.02	0.25
A ₂	0.071	0.087	1.80	2.20
B	0.011	0.018	0.29	0.45
C	0.004	0.009	0.11	0.23
D	0.510	0.530	12.95	13.45
D ₁	0.390	0.398	9.90	10.10
e	0.0315 BSC		0.80 BSC	
L	0.029	0.040	0.73	1.03
α	0°	7°	0°	7°

NOTICE

EXAR Corporation reserves the right to make changes to the products contained in this publication in order to improve design, performance or reliability. EXAR Corporation assumes no responsibility for the use of any circuits described herein, conveys no license under any patent or other right, and makes no representation that the circuits are free of patent infringement. Charts and schedules contained here in are only for illustration purposes and may vary depending upon a user's specific application. While the information in this publication has been carefully checked; no responsibility, however, is assumed for in accuracies.

EXAR Corporation does not recommend the use of any of its products in life support applications where the failure or malfunction of the product can reasonably be expected to cause failure of the life support system or to significantly affect its safety or effectiveness. Products are not authorized for use in such applications unless EXAR Corporation receives, in writing, assurances to its satisfaction that: (a) the risk of injury or damage has been minimized; (b) the user assumes all such risks; (c) potential liability of EXAR Corporation is adequately protected under the circumstances.

Copyright 2001 EXAR Corporation

Datasheet February 2001

Reproduction, in part or whole, without the prior written consent of EXAR Corporation is prohibited.

This datasheet has been download from:

www.datasheetcatalog.com

Datasheets for electronics components.