



Chipsmall Limited consists of a professional team with an average of over 10 year of expertise in the distribution of electronic components. Based in Hongkong, we have already established firm and mutual-benefit business relationships with customers from,Europe,America and south Asia,supplying obsolete and hard-to-find components to meet their specific needs.

With the principle of “Quality Parts,Customers Priority,Honest Operation,and Considerate Service”,our business mainly focus on the distribution of electronic components. Line cards we deal with include Microchip,ALPS,ROHM,Xilinx,Pulse,ON,Everlight and Freescale. Main products comprise IC,Modules,Potentiometer,IC Socket,Relay,Connector.Our parts cover such applications as commercial,industrial, and automotives areas.

We are looking forward to setting up business relationship with you and hope to provide you with the best service and solution. Let us make a better world for our industry!



## Contact us

Tel: +86-755-8981 8866 Fax: +86-755-8427 6832

Email & Skype: info@chipsmall.com Web: www.chipsmall.com

Address: A1208, Overseas Decoration Building, #122 Zhenhua RD., Futian, Shenzhen, China





A New Direction in Mixed-Signal

November 2013

**XRP6141**

## 35A Synchronous Step Down COT Controller

Rev. 1.0.0

### GENERAL DESCRIPTION

The XRP6141 is a synchronous step-down controller for point-of load supplies up to 35A. A wide 4.5V to 22V input voltage range allows for single supply operation from industry standard 5V, 12V and 19.6V rails.

With a proprietary emulated current mode Constant On-Time (COT) control scheme, the XRP6141 provides extremely fast line and load transient response using ceramic output capacitors. It requires no loop compensation hence simplifying circuit implementation and reducing overall component count. The control loop also provides exceptional line regulation and maintains constant operating frequency. A selectable power saving mode, allows the user to operate in discontinuous mode (DCM) at light current loads thereby significantly increasing the converter efficiency.

A host of protection features, including over-current, over-temperature, short-circuit and UVLO, help achieve safe operation under abnormal operating conditions.

### EVALUATION BOARD MANUAL

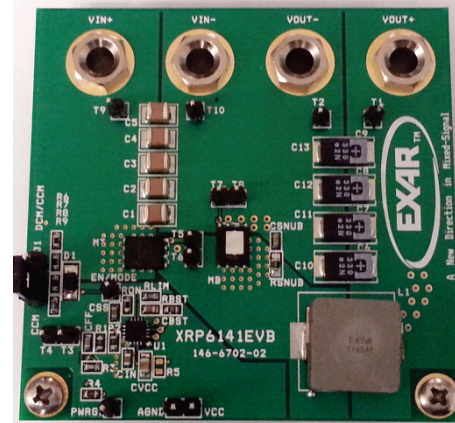

### FEATURES

- **35A Capable Step Down Controller**
  - Wide Input Voltage Range
    - 5V to 22V Single Supply
    - 4.5V to 5.5V Low Vin
  - Integrated high Current 2A/3A Drivers
  - 0.6V to 18V Adjustable Output Voltage
- **Proprietary Constant On-Time Control**
  - No Loop Compensation Required
  - Ceramic Output Cap. Stable operation
  - Programmable 200ns-2μs
  - Quasi Constant 200kHz-800kHz Freq.
  - Selectable CCM or CCM/DCM Operation

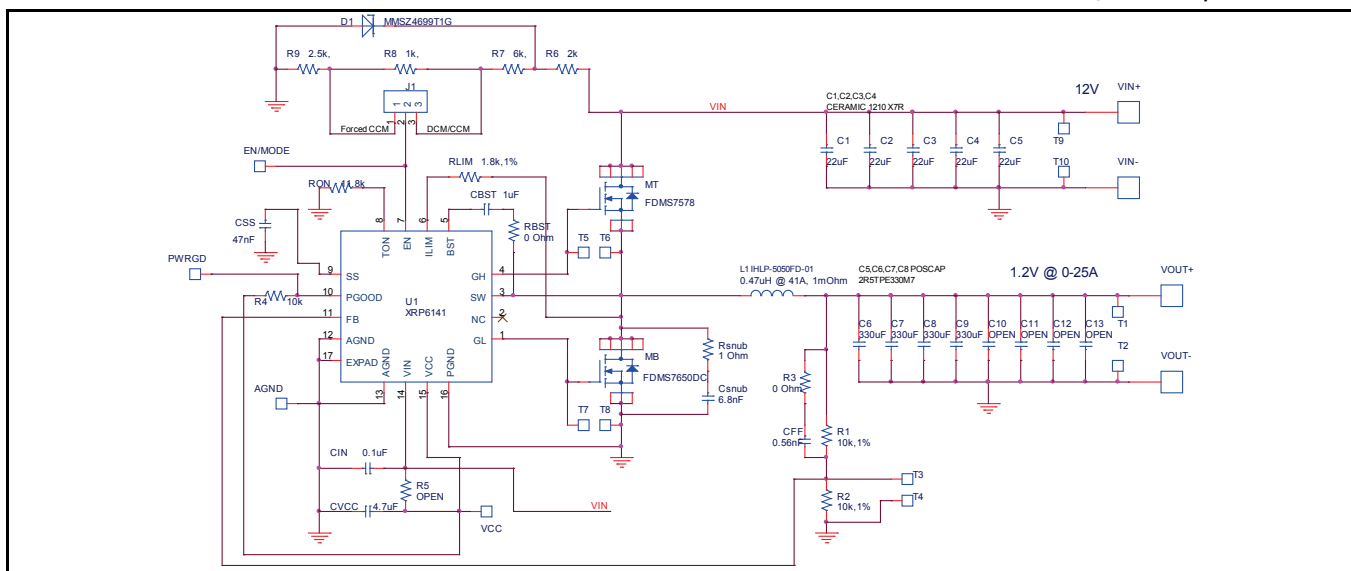

Fig. 1: XRP6141 Evaluation Board Schematics



**PIN ASSIGNMENT**

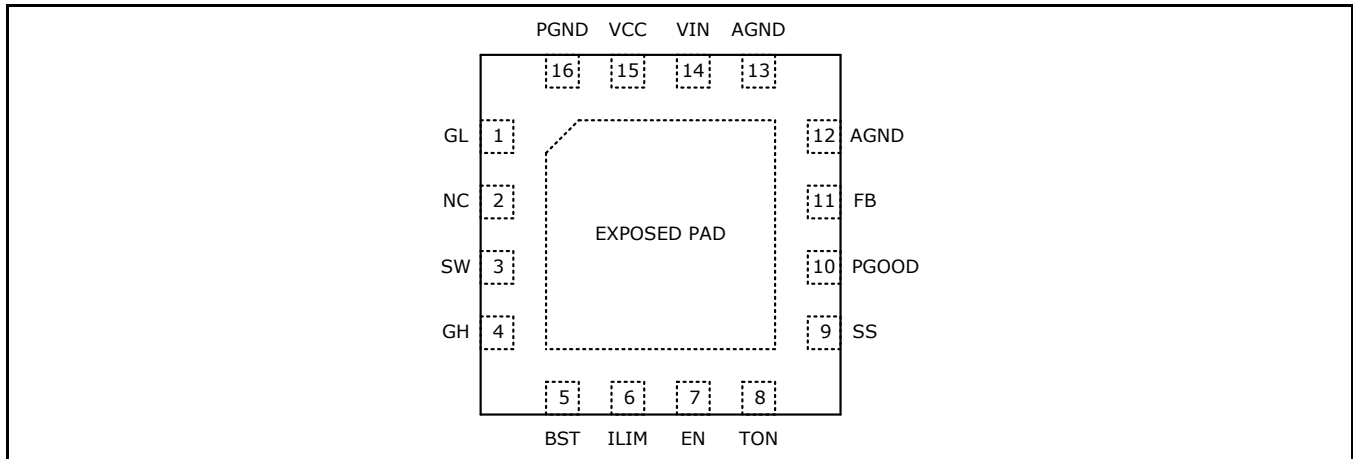

Fig. 2: XRP6141 Pin Assignment

**PIN DESCRIPTION**

Name	Pin Number	Description
GL	1	Driver output for Low-side N-channel synchronous MOSFET.
NC	2	Internally not connected. Leave this pin floating.
SW	3	Lower supply rail for high-side gate driver GH. Connect this pin to the junction between the two external N-channel MOSFETs.
GH	4	Driver output for high-side N-channel switching MOSFET.
BST	5	High-side driver supply pin. Connect a 0.1uF bootstrap capacitor between BST and SW.
ILIM	6	Over-current protection programming. Connect with a resistor to the Drain of the low-side MOSFET.
EN/MODE	7	Precision enable pin. Pulling this pin above 1.9V will turn the IC on and it will operate in Forced CCM. If the voltage is raised above 3.0V then the IC will operate in DCM or CCM depending on load.
TON	8	Constant on-time programming pin. Connect with a resistor to AGND.
SS	9	Soft-Start pin. Connect an external capacitor between SS and AGND to program the soft-start rate based on the 10uA internal source current.
PGOOD	10	Power-good output. This open-drain output is pulled low when $V_{OUT}$ is outside the regulation.
FB	11	Feedback input to feedback comparator. Connect with a set of resistors to $V_{OUT}$ and GND in order to program $V_{OUT}$ .
AGND	12, 13	Analog ground. Control circuitry of the IC is referenced to this pin.
VIN	14	IC supply input. Provides power to internal LDO.
VCC	15	The output of LDO. For operation using a 5V rail, VCC should be shorted to VIN.
PGND	16	Ground for low side driver
Exposed Pad		Thermal pad for heat dissipation. Connect to AGND with a short trace.

**ORDERING INFORMATION**

Refer to XRP6141's datasheet and/or [www.exar.com](http://www.exar.com) for exact and up to date ordering information.



A New Direction in Mixed-Signal

**XRP6141**

## **35A Synchronous Step Down COT Controller**

---

### **USING THE EVALUATION BOARD**

#### **POWERING UP**

Connect the VIN+/VIN- with short/thick leads to power supply. Connect VOUT+/VOUT- with short/thick leads to electronic load. Apply 12V using the power supply. The XRP6141EVB should power up and regulate the output at 1.2V. Rated output current is 25A. Overcurrent protection should trigger at about 34A.

#### **JUMPER J1**

With the jumper set at CCM position the converter will operate in 'Forced CCM' at  $V_{IN}=12V(+/-10\%)$ . In order to operate in Forced CCM over a wider VIN range, remove Jumper and apply an auxiliary voltage in the range of 1.9V-3V to the EN test point.

With the jumper set at DCM/CCM position the converter will operate at DCM/CCM, depending on load, at  $V_{IN}=12V(+/-10\%)$ . In order to operate in DCM/CCM over a wider VIN range, remove Jumper and apply an auxiliary voltage in the range of 3.1V-5V to the EN test point.



**35A Synchronous Step Down COT Controller**

**BILL OF MATERIAL**

Reference Designator	Qty.	Manufacturer	Manufacturer Part Number	Size	Component
PCB	1	Exar	XRP6141EVB		XRP6141 Evaluation kit
U1	1	Exar	XRP6141	QFN-16	Constant On-Time Buck controller
MT	1	FAIRCHILD	FDMS7578	Power SO-8	N-Ch. 25V, 5.8mOhm MOSFET
MB	1	FAIRCHILD	FDMS7650DC	Power SO-8	N-Ch. 30V, 100A, 0.99mOhm, MOSFET
D1	1	ON SEMI	MMSZ4699T1G	SOD-123	Diode Zener 12V, 500MW,
L1	1	VISHAY-DALE	IHLP5050FDERR47M01	13.2x12.9mm	Shielded inductor, 0.47uH, 1mΩ, 41A
C1-C4	4	MURATA	GRM32ER71E226KE15L	1210	CERAMIC CAP., 22uF, 25V, X7R, 10%
C5	0	DONT POPULATE	---	---	---
C6-C9	4	PANASONIC	2R5TPE330M7	7.3X4.3X1.8mm	TANTALUM CAP., 330uF, 2.5V, 2917
C10-C13	0	DONT POPULATE	---	---	---
CBST	1	MURATA	GRM188R71C105KA12D	0603	CERAMIC CAP., 1uF, 16V, X7R, 10%
CFF	1	MURATA	GRM188R71H561KA01D	0603	CERAMIC CAP., 0.56nF, 50V, X7R, 10%
CIN	1	MURATA	GRM188R71H104KA93D	0603	CERAMIC CAP., 0.1uF, 50V, X7R, 10%
CVCC	1	MURATA	GRM21BR71C475KA73L	0805	CERAMIC AP., 4.7uF, 16V, X7R, 10%
CSS	1	MURATA	GRM188R71H473KA61D	0603	CERAMIC CER, 47nF, 50V, X7R, 10%
Csnub	1	MURATA	GRM188R71H682KA01D	0603	CERAMIC CER, 6.8nF, 50V, X7R, 10%
R1, R2, R4	3	PANASONIC	ERJ-3EKF1002V	0603	Resistor 10k, 1/10W, 1%, SMD
R3, RBST	2	PANASONIC	ERJ-3GEY0R00V	0603	Resistor 0Ω, Jumper SMD
R5	0	DONT POPULATE	---	---	---
R9	1	PANASONIC	ERJ-3EKF2491V	0603	Resistor 2.49K Ohm, 1/10w, 1%, SMD
R6	1	PANASONIC	ERJ-3EKF2001V	0603	Resistor 2K Ohm, 1/10W, 1%, SMD
R7	1	PANASONIC	ERJ-3EKF6041V	0603	Resistor 6.04K Ohm, 1/10W, 1%, SMD
R8	1	PANASONIC	ERJ-3EKF1001V	0603	Resistor 1K Ohm, 1/10W, 1%, SMD
RLIM	1	PANASONIC	ERJ-3EKF1821V	0603	Resistor 1.82k, 1/10W, 1%, SMD
RON	1	PANASONIC	ERJ-3EKF1182V	0603	Resistor 11.8K Ohm ohm, 1/10W,1%, SMD
Rsnub	1	PANASONIC	ERJ-6RQF1R0V	0805	Resistor 1.0 Ohm, 1/8W,1%, SMD
J1	1	Würth Elektronik	61300311121		3-PIN CONNECTOR
VIN+, VIN-, VOUT+, VOUT-	4	POMONA	3267	1/4-32	Banana Jack
T3/T4, T5/T6, T7/T8, AGND/VCC	8	Würth Elektronik	61300211121		DUAL TEST POINT
T1, T2, T9, T10, PWERGD, EN/MODE	6	Würth Elektronik	61300111121		SINGLE Test Point Post
STAND1, STAND 2	2	Keystone	4-40 X 1/2		STANDOFF

EVALUATION BOARD LAYOUT

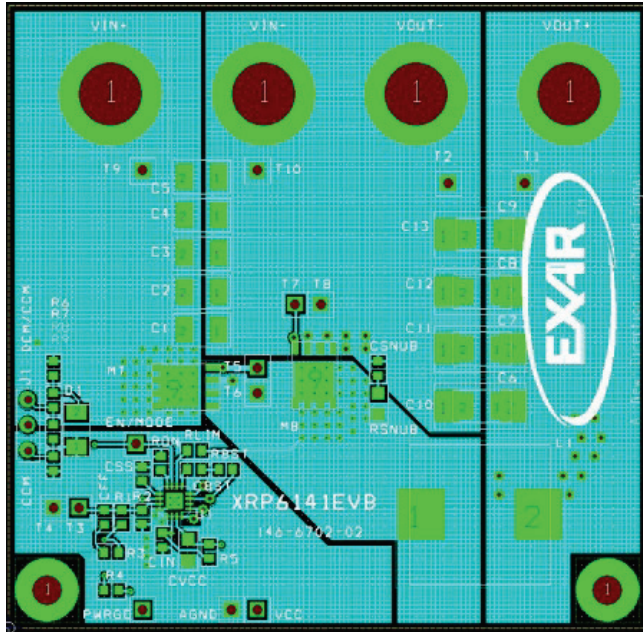

Fig. 3: Component Placement - Top Side

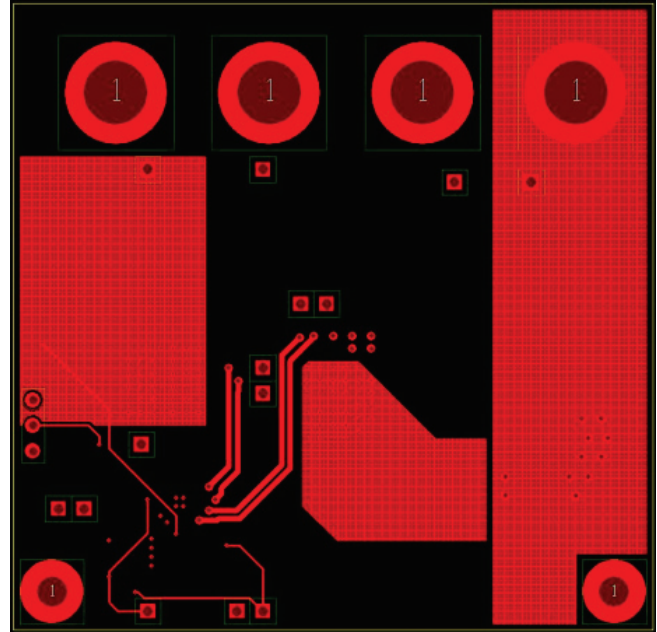

Fig. 4: Bottom Side

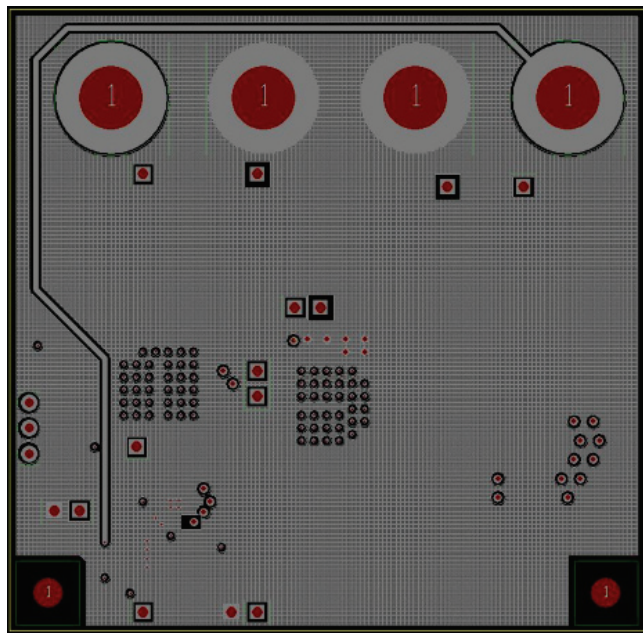

Fig. 5: Layer 2

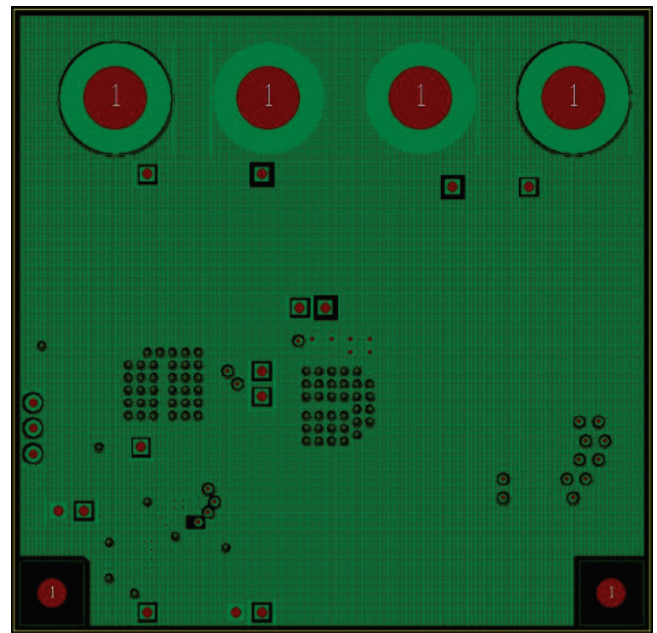

Fig. 6: Layer 3



**DOCUMENT REVISION HISTORY**

Revision	Date	Description
1.0.0	11/22/13	Initial release of document

**BOARD REVISION HISTORY**

Board Revision	Date	Description
146-6702-03	11/22/13	Initial release of evaluation board

**FOR FURTHER ASSISTANCE**

Email:

[customersupport@exar.com](mailto:customersupport@exar.com)  
[powertechsupport@exar.com](mailto:powertechsupport@exar.com)

Exar Technical Documentation:

<http://www.exar.com/TechDoc/default.aspx?>



**EXAR CORPORATION**

**HEADQUARTERS AND SALES OFFICES**

48720 Kato Road  
Fremont, CA 94538 – USA  
Tel.: +1 (510) 668-7000  
Fax: +1 (510) 668-7030  
[www.exar.com](http://www.exar.com)

**NOTICE**

EXAR Corporation reserves the right to make changes to the products contained in this publication in order to improve design, performance or reliability. EXAR Corporation assumes no responsibility for the use of any circuits described herein, conveys no license under any patent or other right, and makes no representation that the circuits are free of patent infringement. Charts and schedules contained here in are only for illustration purposes and may vary depending upon a user's specific application. While the information in this publication has been carefully checked; no responsibility, however, is assumed for inaccuracies.

EXAR Corporation does not recommend the use of any of its products in life support applications where the failure or malfunction of the product can reasonably be expected to cause failure of the life support system or to significantly affect its safety or effectiveness. Products are not authorized for use in such applications unless EXAR Corporation receives, in writing, assurances to its satisfaction that: (a) the risk of injury or damage has been minimized; (b) the user assumes all such risks; (c) potential liability of EXAR Corporation is adequately protected under the circumstances.

Reproduction, in part or whole, without the prior written consent of EXAR Corporation is prohibited.