



Chipsmall Limited consists of a professional team with an average of over 10 year of expertise in the distribution of electronic components. Based in Hongkong, we have already established firm and mutual-benefit business relationships with customers from,Europe,America and south Asia,supplying obsolete and hard-to-find components to meet their specific needs.

With the principle of “Quality Parts,Customers Priority,Honest Operation,and Considerate Service”,our business mainly focus on the distribution of electronic components. Line cards we deal with include Microchip,ALPS,ROHM,Xilinx,Pulse,ON,Everlight and Freescale. Main products comprise IC,Modules,Potentiometer,IC Socket,Relay,Connector.Our parts cover such applications as commercial,industrial, and automotives areas.

We are looking forward to setting up business relationship with you and hope to provide you with the best service and solution. Let us make a better world for our industry!



Contact us

Tel: +86-755-8981 8866 Fax: +86-755-8427 6832

Email & Skype: info@chipsmall.com Web: www.chipsmall.com

Address: A1208, Overseas Decoration Building, #122 Zhenhua RD., Futian, Shenzhen, China



GENERAL DESCRIPTION

The XRP6668 is a dual channel synchronous current mode PWM step down (buck) converter capable of delivering up to 1 Amp of current per channel and optimized for portable battery-operated applications.

Based on a current mode 1.5MHz constant frequency PWM control scheme, the XRP6668 reduces the overall component count and solution footprint as well as provides a low output voltage ripple and excellent line and load regulation. It also implements a PFM mode to improve light load efficiency as well as a 100% duty cycle LDO mode. Output voltage is adjustable to as low as 0.6V with a better than 3% accuracy while a low quiescent current supports the most stringent battery operating conditions.

Built-in over temperature and under voltage lock-out protections insure safe operations under abnormal operating conditions.

The XRP6668 is offered in a RoHS compliant, "green"/halogen free 8-pin exposed pad SOIC package.

EVALUATION BOARD MANUAL

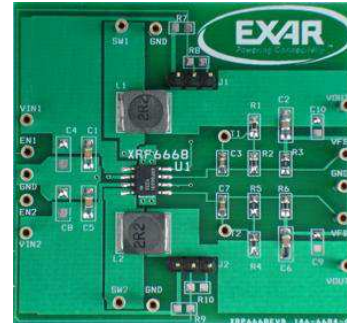

FEATURES

- **Dual Channel Step Down Converter**
- **Guaranteed Dual 1A/1A Output Current**
 - Input Voltage: 2.5V to 5.5V
- **1.5MHz PWM Current Mode Control**
 - PFM Mode Operations at Light Load
 - 100% Duty Cycle LDO Mode Operations
- **Adjustable Output Voltage Range**
- **Internal Compensation Network**
- **30µA Quiescent Current**
- **Over Temperature & UVLO Protections**

EVALUATION BOARD SCHEMATICS

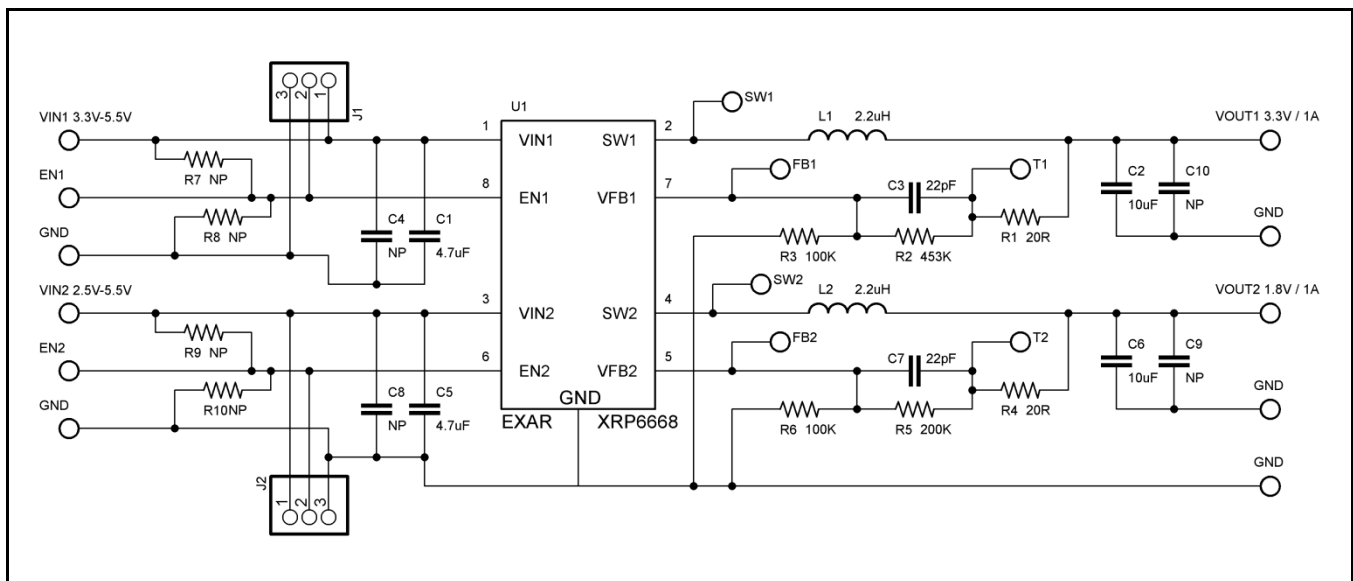

Fig. 1: XRP6668EVB Evaluation Board Schematics

PIN ASSIGNMENT

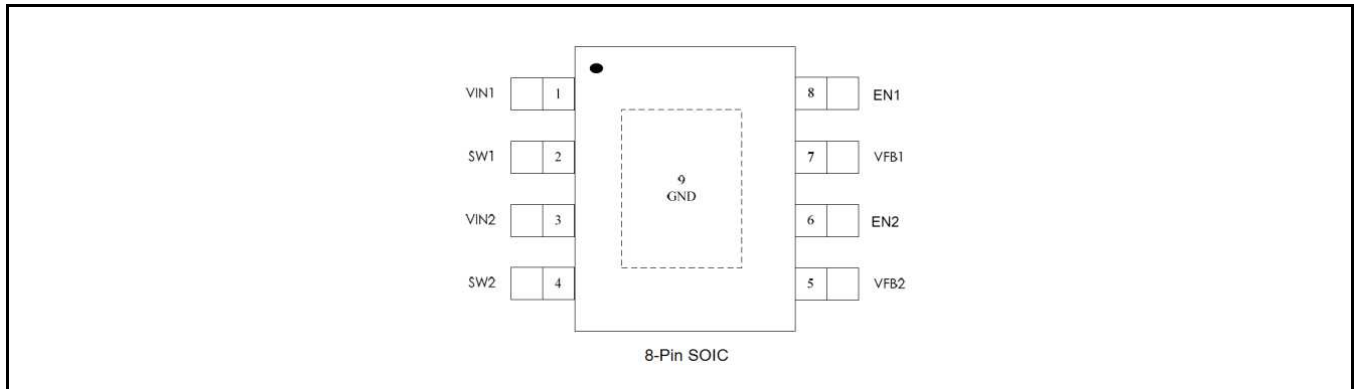

Fig. 2: XRP6658 Pin Assignment

PIN DESCRIPTION

Name	Pin Number	Description
VIN1	1	Channel 1 Power Input Pin. Must be closely decoupled to GND pin with a 4.7 μ F or greater ceramic capacitor.
SW1	2	Channel 1 Switch Pin. Must be connected to Inductor. This pin connects to the drains of the internal main and synchronous power MOSFET switches.
VIN2	3	Channel 2 Power Input Pin. Must be closely decoupled to GND pin with a 4.7 μ F or greater ceramic capacitor.
SW2	4	Channel 2 Switch Pin. Must be connected to Inductor. This pin connects to the drains of the internal main and synchronous power MOSFET switches.
VFB2	5	Channel 2 Feedback Pin. Receives the feedback voltage from an external resistive divider across the output.
EN2	6	Channel 2 Enable Pin. Minimum 1.2V to enable the device. Maximum 0.4V to shutdown the device.
VFB1	7	Channel 1 Feedback Pin. Receives the feedback voltage from an external resistive divider across the output.
EN1	8	Channel 1 Enable Pin. Minimum 1.2V to enable the device. Maximum 0.4V to shutdown the device.
GND	Exposed Pad	Connect to GND.

ORDERING INFORMATION

Refer to XRP6668's datasheet and/or www.exar.com for exact and up to date ordering information.



XRP6668EVB

1A/1A Dual Channel 1.5MHz Sync. Step Down Converter

USING THE EVALUATION BOARD

INITIAL SETUP

Set the input supply to a voltage between 2.5V to 5.5V and connect it to VIN and GND connectors on the left side of the evaluation board. Connect the load to the VOUT and GND connectors on the right hand side of the board. Check to make sure that jumper J1 is set to VIN. The board will power-up and regulate to the desired output voltage VOUT

set by the feedback resistors. The board will operate with a load current I_{OUT} of up to 1A and provide efficiency equal to figures 4 and 5 of XRP6658 datasheet.

JUMPER J1 FUNCTION

Jumper J1 can be used to either short EN pin to VIN or to GND. The Board is supplied from EXAR with the jumper set to connect EN to VIN.



XRP6668EVB 1A/1A Dual Channel 1.5MHz Sync. Step Down Converter

EVALUATION BOARD SCHEMATICS

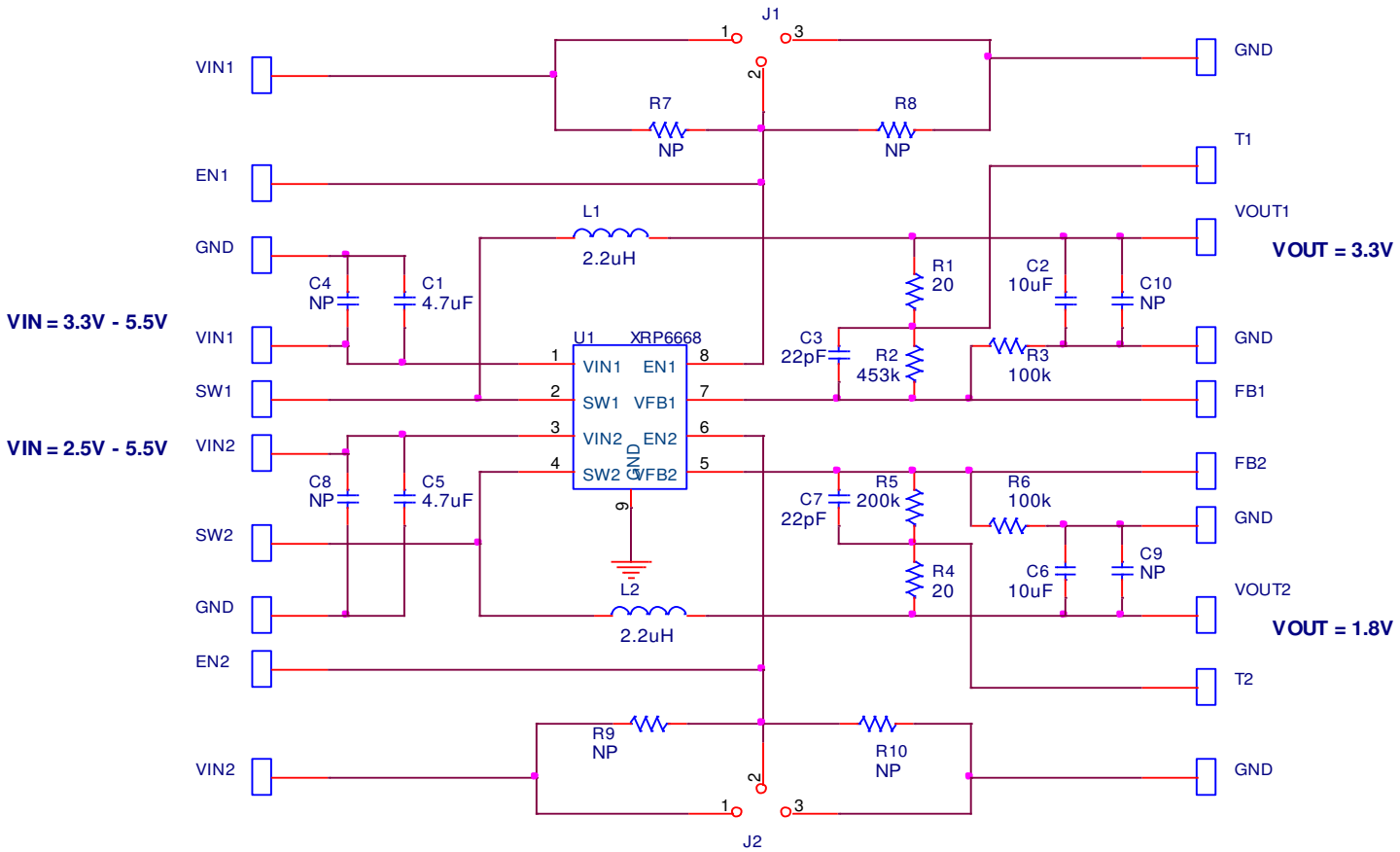



BILL OF MATERIAL

Ref.	Qty	Manufacturer	Part Number	Size	Component
Eval BD	1	Exar Corp	XRP6668EVB		XRP6668 Evaluation Board
U1	1	Exar Corp	XRP6668	ESOP-8L	Synchronous Step-Down Regulator
C1, C5	2	Murata	GRM21BR71C475KA73L	0805	Ceramic 4.7µF, 16V, X7R
C4, C8	2				Not populated
C2, C6	2	Murata	GRM21BR71A106KE51L	0805	Ceramic 10µF, 10V, X7R
C9, C10	2				Not populated
C3, C7	2	Murata	GRM1885C1H220JA01D	0603	Ceramic 22pF, 50V, C0G
L1, L2	2	Würth Elektronik	7440430022	4.8mm x 4.8mm x 2.8mm	Inductor 2.2µH, 2.5A, 23mΩ
R1, R4	2	Vishay	CRCW060320R0FKTA	0603	20Ω Resistor, 0.1W, 1%
R2	1	Vishay	CRCW0603453KFKTA	0603	453KΩ Resistor, 0.1W, 1%
R5	1	Vishay	CRCW0603200KFKTA	0603	200KΩ Resistor, 0.1W, 1%
R3, R6	2	Vishay	CRCW0603100KFKTA	0603	100KΩ Resistor, 0.1W, 1%
J1, J2	2	Würth Elektronik	61303611121	0.64mm SQ x 6mm	3 Pin Header, 2.54mm pitch
J1, J2 (Jumpers)	2	Würth Elektronik	609002115121	0.1"	Jumper short
Test Point VIN, VOUT, EN, SW, GND, FB, TP	16	Mill-Max	0300-115-01-4727100	0.042" diameter	Test Point Post

EVALUATION BOARD LAYOUT

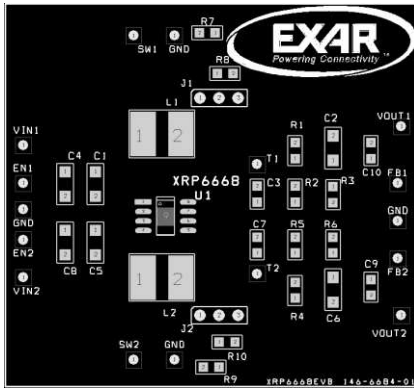

Fig. 3: Component Placement – Top Side

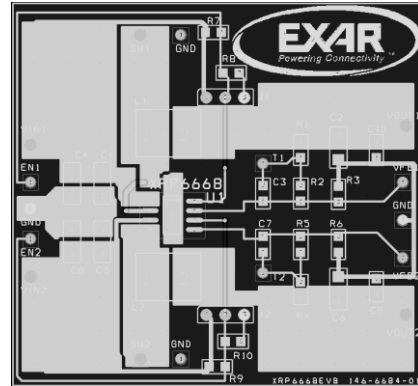

Fig. 4: Component Placement 2 – Top Side

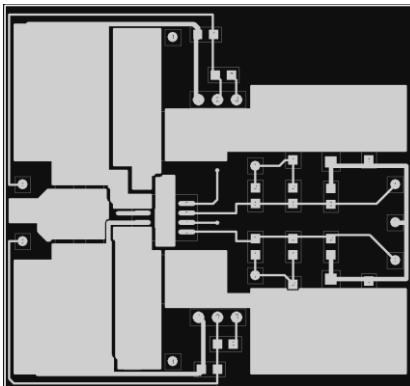

Fig. 5: Layout – Top Side

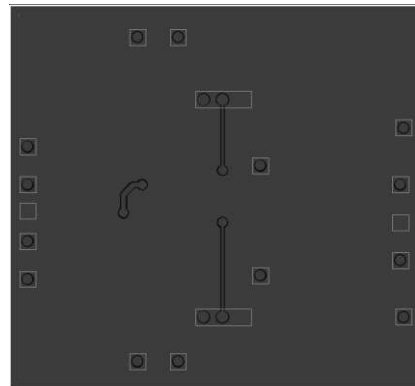

Fig. 6: Layout - Bottom



XRP6668EVB

1A/1A Dual Channel 1.5MHz Sync. Step Down Converter

REVISION HISTORY

Revision	Date	Description
1.0.0	09/16/2010	Initial release of document
1.1.0	02/07/2012	Updated bill of material and schematics

FOR FURTHER ASSISTANCE

Email: customersupport@exar.com
Exar Technical Documentation: <http://www.exar.com/TechDoc/default.aspx?>

EXAR CORPORATION

HEADQUARTERS AND SALES OFFICES

48720 Kato Road
Fremont, CA 94538 – USA
Tel.: +1 (510) 668-7000
Fax: +1 (510) 668-7030
www.exar.com



NOTICE

EXAR Corporation reserves the right to make changes to the products contained in this publication in order to improve design, performance or reliability. EXAR Corporation assumes no responsibility for the use of any circuits described herein, conveys no license under any patent or other right, and makes no representation that the circuits are free of patent infringement. Charts and schedules contained here in are only for illustration purposes and may vary depending upon a user's specific application. While the information in this publication has been carefully checked; no responsibility, however, is assumed for inaccuracies.

EXAR Corporation does not recommend the use of any of its products in life support applications where the failure or malfunction of the product can reasonably be expected to cause failure of the life support system or to significantly affect its safety or effectiveness. Products are not authorized for use in such applications unless EXAR Corporation receives, in writing, assurances to its satisfaction that: (a) the risk of injury or damage has been minimized; (b) the user assumes all such risks; (c) potential liability of EXAR Corporation is adequately protected under the circumstances.

Reproduction, in part or whole, without the prior written consent of EXAR Corporation is prohibited.