



Chipsmall Limited consists of a professional team with an average of over 10 year of expertise in the distribution of electronic components. Based in Hongkong, we have already established firm and mutual-benefit business relationships with customers from,Europe,America and south Asia,supplying obsolete and hard-to-find components to meet their specific needs.

With the principle of “Quality Parts,Customers Priority,Honest Operation,and Considerate Service”,our business mainly focus on the distribution of electronic components. Line cards we deal with include Microchip,ALPS,ROHM,Xilinx,Pulse,ON,Everlight and Freescale. Main products comprise IC,Modules,Potentiometer,IC Socket,Relay,Connector.Our parts cover such applications as commercial,industrial, and automotives areas.

We are looking forward to setting up business relationship with you and hope to provide you with the best service and solution. Let us make a better world for our industry!



Contact us

Tel: +86-755-8981 8866 Fax: +86-755-8427 6832

Email & Skype: info@chipsmall.com Web: www.chipsmall.com

Address: A1208, Overseas Decoration Building, #122 Zhenhua RD., Futian, Shenzhen, China



GENERAL DESCRIPTION

The XRP7620EVB Evaluation Board is designed to demonstrate and evaluate the performance of the XRP7620 device, a multi purpose 4-channel independently adjustable current sink driver.

Optimized for LED backlighting and RGBW/RGBA color mixing applications, the XRP7620 supports an industry standard 2-line I²C serial interface providing full independent control of each channel up to a current of 31.5mA in steps of 500µA.

The XRP7620 operates from 2.7V to 5.5V input with 100mV dropout voltage and allows a wide range of forward voltage LEDs.

The evaluation board is a completely assembled and tested surface mount board which provides easy probe access points so that the user can quickly connect LEDs and measure electrical characteristics. The Evaluation Board schematic diagram is shown in Figure 1.

EVALUATION BOARD MANUAL

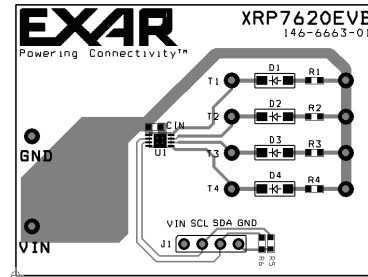

FEATURES

- **4-Channel LED Current Sink Driver**
- **Individual Channel Current Control**
 - Up to 31.5mA per channel / 500µA Steps
 - 100mV Channel Dropout Voltage
- **I²C Serial Interface**
- **2.7V - 5.5V Input Voltage Range**
- **3% Channel Current Matching**
- **Configuration Retention in Shutdown**
- **Shutdown Current <1µA**
- **Thermal and UVLO Built-in Protection**
- **2x3mm 8-Pin DFN package**

EVALUATION BOARD SCHEMATICS

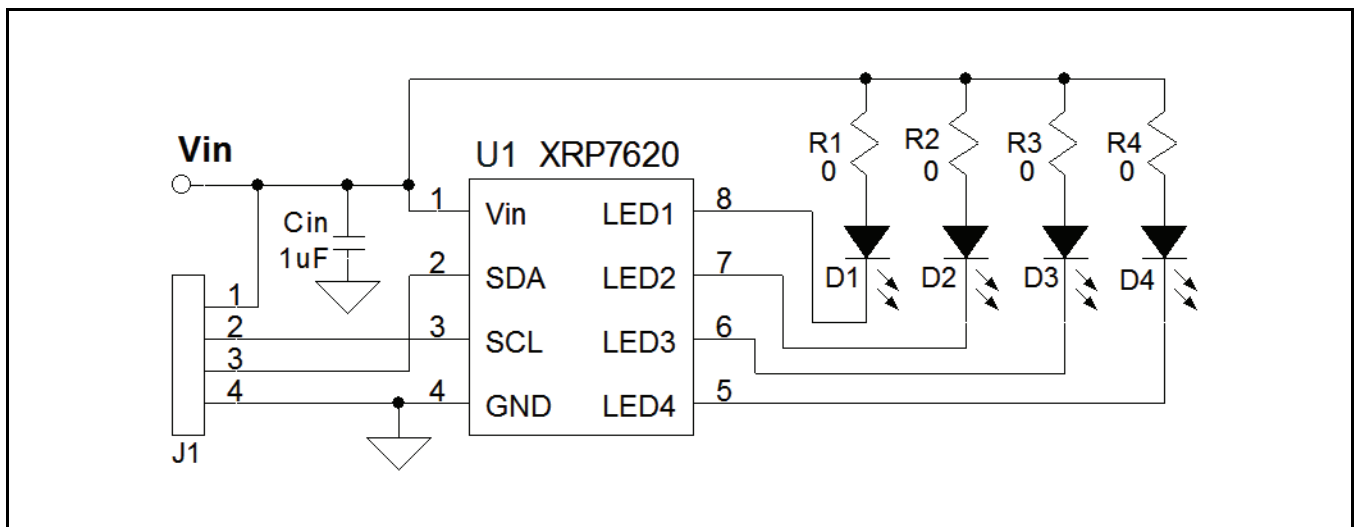

Fig. 1: XRP7620 Evaluation Board Schematics

PIN ASSIGNMENT

Fig. 2: XRP7620 Pin Assignment

PIN DESCRIPTION

Name	Pin Number	Description
VIN	1	Connect a 1 μ F decoupling capacitor between this pin and the ground pin (pin 4).
SDA	2	I2C Interface Serial Data Input-Output.
SCL	3	I2C Interface Serial Clock Input.
GND	4	Ground Signal.
LED4	5	LED 4 Input. Connect a LED between this pin and VIN. Current Value is set by the serial interface.
LED3	6	LED 3 Input. Connect a LED between this pin and VIN. Current Value is set by the serial interface.
LED2	7	LED 2 Input. Connect a LED between this pin and VIN. Current Value is set by the serial interface.
LED1	8	LED 1 Input. Connect a LED between this pin and VIN. Current Value is set by the serial interface.

ORDERING INFORMATION

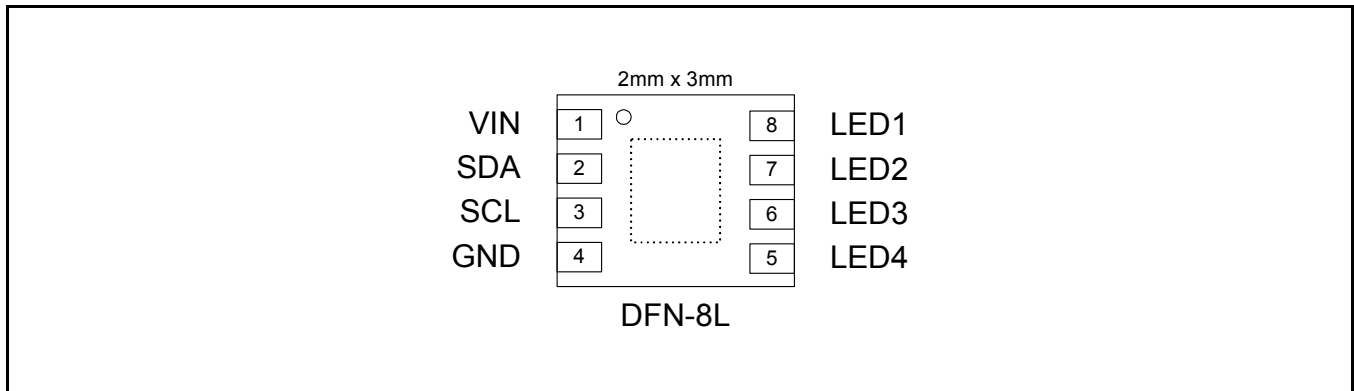
Part Number	Temperature Range	Marking	Package	Packing Quantity	Note 1	I ² C Address
XRP7620IH-F	-40°C ≤ T _J ≤ +100°C	7620I YYWWFX	DFN-8L	Bulk	Green Halogen Free	0x70
XRP7620IHTR-F	-40°C ≤ T _J ≤ +100°C	7620I YYWWFX	DFN-8L	3K/Tape & Reel	Green Halogen Free	0x70
XRP7620EVB	XRP1234 Evaluation Board					

Ordering information is provided for reference only, refer to XRP7620's datasheet and/or www.exar.com for exact and up to date ordering information.

USING THE EVALUATION BOARD

POWERING UP THE XRP7620 CIRCUIT

1. Connect VIN from VIN to GND (V_{IN} range 2.7V to 5.5V).
2. Apply I2C connections of SDA, SCL and GND to J1.
3. Use I2C serial connection and software to control LED1 to LED4.

To measure current through LED1 to LED4, remove zero ohm resistors at R1 to R4 and add SM 0603 1 Ohm resistors to R1 to R4. Then measure current with DVM across R1 to R4.

Note: 1mV across R1 equals 1mA of current through D1 LED.

LED CURRENT PROGRAMMING

The XRP7620 provides I²C serial interface independently control each LED up to a current of 31.5mA in steps of 500µA. Please refer to the application information section of the data sheet to program specific current for each LED channel.

For typical test result please refer to the data sheet.

EVALUATION BOARD LAYOUT

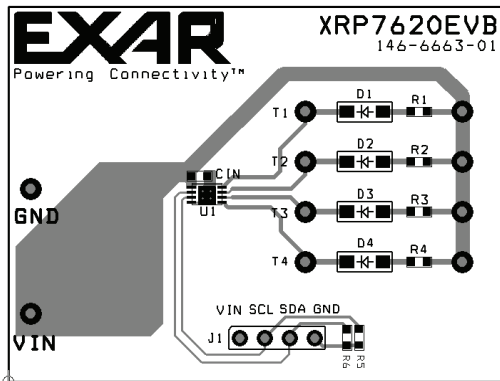

Fig. 3: XRP7620 Evaluation Board Layout Component Side

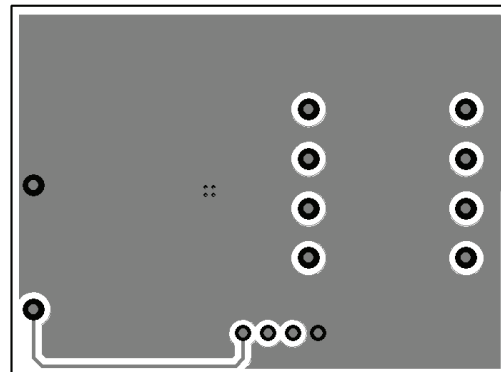

Fig. 4: XRP7620 Evaluation Board Layout Solder Side

BILL OF MATERIAL

Ref.	Qty	Manufacturer	Part Number	Size	Component	Vendor
Board	1	Exar Corp.	146-6663-01	2"x1.5"	XRP7620EVB Eval board	Exar Corp.
U1	1	Exar Corp.	XRP7620IH-F	DFN-8L	4 Channel I2C Controlled LED driver	Exar Corp.
C1	1	muRata	GRM188R60J105K	0603	Ceramic 1uF, 6.3V, X5R	muRata.com
R1,R2,R3,R4	4	Vishay	CRCW06030000Z0EA	0603	0 Ohm Resistor, 1/10W	Vishay.com
J1	1	Würth Electronic	61304011021	0.23"x0.12"	4-Pin Right Angle Header	we-online.com
TP	6	Mill-Max	0300-115-01-4727100	.042" dia	Test Point Female Pin	digikey.com

Table 1: XRP7620 Evaluation Board Bill of Material



REVISION HISTORY

Revision	Date	Description
1.0.0	06/01/09	Initial release of document

FOR FURTHER ASSISTANCE

Email:

customersupport@exar.com

Exar Technical Documentation:

<http://www.exar.com/TechDoc/default.aspx?>

EXAR CORPORATION

HEADQUARTERS AND SALES OFFICES

48720 Kato Road

Fremont, CA 94538 – USA

Tel.: +1 (510) 668-7000

Fax: +1 (510) 668-7030

www.exar.com



NOTICE

EXAR Corporation reserves the right to make changes to the products contained in this publication in order to improve design, performance or reliability. EXAR Corporation assumes no responsibility for the use of any circuits described herein, conveys no license under any patent or other right, and makes no representation that the circuits are free of patent infringement. Charts and schedules contained here in are only for illustration purposes and may vary depending upon a user's specific application. While the information in this publication has been carefully checked; no responsibility, however, is assumed for inaccuracies.

EXAR Corporation does not recommend the use of any of its products in life support applications where the failure or malfunction of the product can reasonably be expected to cause failure of the life support system or to significantly affect its safety or effectiveness. Products are not authorized for use in such applications unless EXAR Corporation receives, in writing, assurances to its satisfaction that: (a) the risk of injury or damage has been minimized; (b) the user assumes all such risks; (c) potential liability of EXAR Corporation is adequately protected under the circumstances.

Reproduction, in part or whole, without the prior written consent of EXAR Corporation is prohibited.