



Chipsmall Limited consists of a professional team with an average of over 10 year of expertise in the distribution of electronic components. Based in Hongkong, we have already established firm and mutual-benefit business relationships with customers from,Europe,America and south Asia,supplying obsolete and hard-to-find components to meet their specific needs.

With the principle of “Quality Parts,Customers Priority,Honest Operation,and Considerate Service”,our business mainly focus on the distribution of electronic components. Line cards we deal with include Microchip,ALPS,ROHM,Xilinx,Pulse,ON,Everlight and Freescale. Main products comprise IC,Modules,Potentiometer,IC Socket,Relay,Connector.Our parts cover such applications as commercial,industrial, and automotives areas.

We are looking forward to setting up business relationship with you and hope to provide you with the best service and solution. Let us make a better world for our industry!



## Contact us

Tel: +86-755-8981 8866 Fax: +86-755-8427 6832

Email & Skype: info@chipsmall.com Web: www.chipsmall.com

Address: A1208, Overseas Decoration Building, #122 Zhenhua RD., Futian, Shenzhen, China



## FEATURES

- Single 5V Supply
- Receiver Input Can Be Either Balanced or Unbalanced
- Up To 8.448Mbps Operation In Both Tx and Rx Directions

- TTL Compatible Interface
- Device Can Be Used as a Line Interface Unit Without Clock Recovery

## APPLICATIONS

- T1, T2, E1 & E2 Rates, PCM Line Interface
- Network Multiplexing and Terminating Equipment

## GENERAL DESCRIPTION

The XR-T5683A is a PCM line interface chip consisting of both transmit and receive circuitry. This device is offered in a plastic dual in-line (PDIP) or in a surface mount package (SOIC). The maximum bit rate of the chip is 8.448Mbps, and the signal level to the receiver can be

attenuated by -10dB cable loss at one-half the bit rate. At nominal supply voltage operation, the typical current consumption is 40mA.

## ORDERING INFORMATION

Part No.	Package	Operating Temperature Range
XR-T5683AIP	18 Lead 300 Mil PDIP	-40°C to +85°C
XR-T5683AID	18 Lead 300 Mil JEDEC SOIC	-40°C to +85°C

## BLOCK DIAGRAM

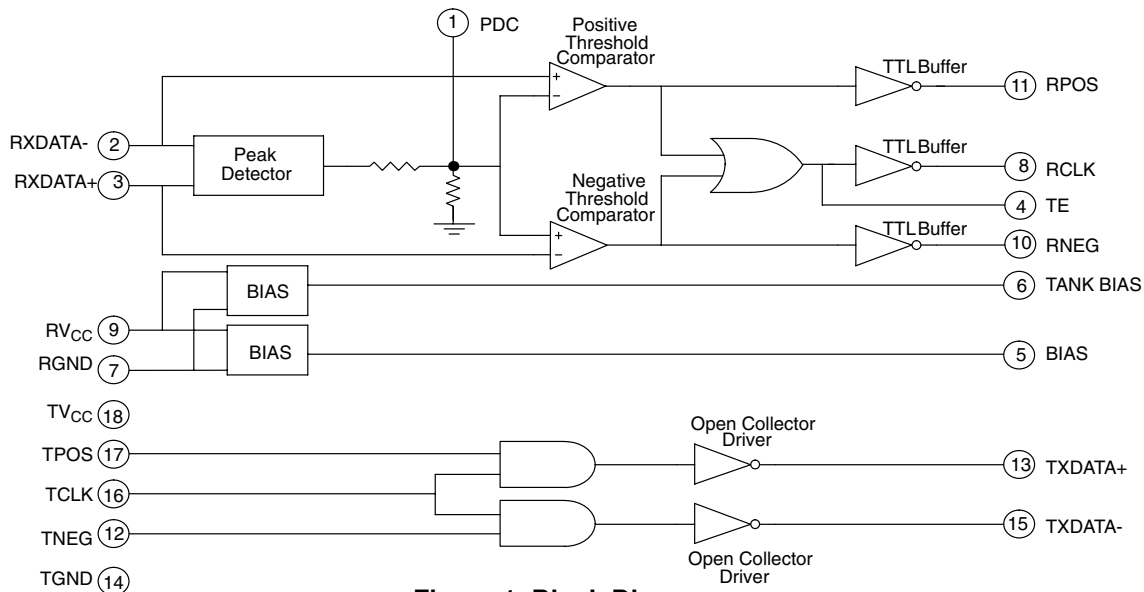
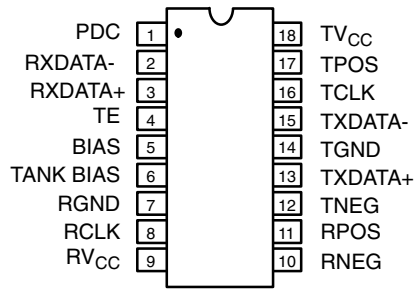
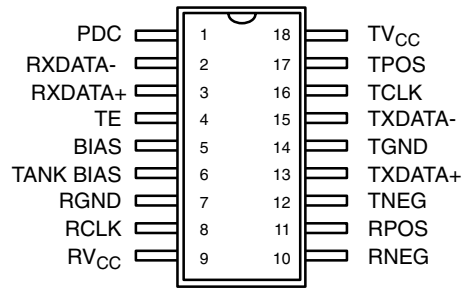

Figure 1. Block Diagram

## PIN CONFIGURATION



18 Lead PDIP (0.300'')



18 Lead SOIC (JEDEC, 0.300'')

## PIN DESCRIPTION

Pin #	Symbol	Type	Description
1	PDC		<b>Peak Detector Capacitor.</b> This pin should be connected to a 0.1 $\mu$ F capacitor.
2	RXDATA-	I	<b>Receive Analog Input Positive.</b> Line analog input.
3	RXDATA+	I	<b>Receive Analog Input Negative.</b> Line analog input.
4	TE	O	<b>Tank Excitation Output.</b> This output connects to one side of the tank circuitry.
5	BIAS	O	<b>Bias.</b> This output is to be connected to the center tap of the receive transformer.
6	TANK BIAS	O	<b>Tank Bias.</b> The tank circuitry is biased via this output.
7	RGND		<b>Receiver Ground.</b> To minimize ground interference a separate pin is used to ground the receive section.
8	RCLK	O	<b>Recovered Receive Clock.</b> Recovered clock signal to the terminal equipment.
9	RV <sub>CC</sub>		<b>Receive Supply Voltage.</b> 5V supply voltage to the receive section.
10	RNEG	O	<b>Receive Negative Data.</b> Negative pulse data output to the terminal equipment (active low).
11	RPOS	O	<b>Receive Positive Data.</b> Positive pulse data output to the terminal equipment (active low).
12	TNEG	I	<b>Transmit Negative Data.</b> TNEG is valid while TCLK is high.
13	TXDATA+	O	<b>Transmit Positive Output.</b> Transmit bipolar signal is driven to the line via a transformer.
14	TGND		<b>Transmit Ground.</b>
15	TXDATA-	O	<b>Transmit Negative Output.</b> Transmit bipolar signal is driven to the line via a transformer.
16	TCLK	I	<b>Transmit Clock.</b> Timing element for TPOS and TNEG.
17	TPOS	I	<b>Transmit Positive Data.</b> TPOS is valid while TCLK is high.
18	TV <sub>CC</sub>		<b>Transmit Supply Voltage.</b> 5V supply voltage to the transmit section.

## ELECTRICAL CHARACTERISTICS

Test Conditions:  $V_{CC} = 5.0V \pm 5\%$ ,  $T_A = 25^\circ C$ , Unless Otherwise Specified.

Parameters	Min.	Typ.	Max.	Unit	Conditions
<b>DC Electrical Characteristics</b>					
Supply Voltage	4.75	<b>5</b>	5.25	V	
Supply Current		40	<b>55</b>	mA	Total Current to Pin 9 & Pin 18 Transmitter Outputs Open
<b>Receiver Section</b>					
Tank Drive Current	<b>300</b>	500	<b>700</b>	$\mu A$	Measured at Pin 4, $V_{CC} = 5V$
Clock Output Low		0.3	<b>0.6</b>	V	Measured at Pin 8, $I_{OL} = 1.6mA$
Clock Output High	<b>3.0</b>	3.6		V	Measured at Pin 8, $I_{OH} = -400\mu A$
Data Output Low		0.3	<b>0.6</b>	V	Measured at Pin 10 & 11, $I_{OL} = 1.6mA$
Data Output High	<b>3.0</b>	3.6		V	Measured at Pin 10 & 11, $I_{OH} = -400\mu A$
<b>Transmitter Section</b>					
Driver Output Low	<b>0.6</b>	0.8	<b>1.0</b>	V	Measured at Pin 13 & 15, $I_{OL} = 40mA$
Output Leakage Current		0	<b>100</b>	$\mu A$	Measured in Off State, Output Pull-up to + 20V
Input High Voltage	<b>2.2</b>		$V_{CC}$	V	Measured at Pin 12, 16 & 17, $I_{OL} = 40mA$ , $V_{OL} = 1.0V$
Input Low Voltage			<b>0.8</b>	V	Measured at Pin 12, 16 & 17, Output Off
Input Low Current			<b>-1.6</b>	mA	Measured at Pin 12, 16 & 17, Input Low Voltage = 0.4V
Input High Current			<b>40</b>	$\mu A$	Measured at Pin 12, 16 & 17, Input High Voltage = 2.7V
Output Low Current			<b>40</b>	mA	Measured at Pin 13 & 15, $V_{OL} = 1.0V$
<b>AC Electrical Characteristics</b>					
<b>Receiver Section</b>					
Input Level		6	<b>6.6</b>	Vpp	Measured Between Pin 2 & 3
Loss Input Signal Alarm Level		1.6		Vpp	Measured Between Pin 2 & 3, Alarm on Pull Data Output High
Input Impedance at 8,448MHz		2.5		k $\Omega$	Measured Between Pin 2 & 3, With Sinewave Input
Clock Duty Cycle	<b>35</b>	50	<b>65</b>	%	Measured at Pin 8 at 2.0V
Clock Rise & Fall Time		20		ns	Measured at Pin 8, $C_L = 15pF$
Data Pulse Width	<b>35</b>	50	<b>75</b>	% of clock period	Measured at Pin 10 & 11, at 1V DC Level, Cable Loss = 0

### Notes

**Bold face parameters** are covered by production test and guaranteed over operating temperature range.

## ELECTRICAL CHARACTERISTICS (CONT'D)

Parameters	Min.	Typ.	Max.	Unit	Conditions
<b>AC Electrical Characteristics (Cont'd)</b>					
<b>Transmitter Section</b>					
Pulse Width at 8.448MHz	<b>53</b>		<b>65</b>	ns	Measured at Pin 13 & 15, See <b>Figure 6</b>
Output Rise Time		12	<b>25</b>	ns	See <i>Figure 5</i>
Output Fall Time		12	<b>25</b>	ns	See <i>Figure 5</i>
Output Pulse Imbalance		2.5		ns	At 50% Output Level

Specifications are subject to change without notice

### Notes

**Bold face parameters** are covered by production test and guaranteed over operating temperature range.

## ABSOLUTE MAXIMUM RATINGS

Supply Voltage . . . . . +20V

Storage Temperature . . . . . -65°C to +150°C

## SYSTEM DESCRIPTION

The incoming bipolar PCM signal which is attenuated and distorted by the cable is applied to the threshold comparator and the peak detector . The peak detector generates a DC reference for the threshold comparator for data and clock extraction. An external tank circuit tuned to the appropriate frequency is added for the later operation. The clock signal, data (+) and data (-) all go through a similar level shifter to be converted into TTL level to be compatible for digital processing.

In the transmit direction, the output drivers consist of two identical TTL inputs with open collector output stages.

The maximum low level current these output stages can sink is 40mA. With full width data (NRZ) applied to the inputs together with a synchronized clock, the output will generate a bipolar signal when driving a center-tapped transformer. A block diagram of the XR-T5683A is shown in *Figure 1*.

The clock recovery uses an external tank circuit. The receive data will create an excitation for the tank circuitry which in turn will create a recovered, received clock (RCLK).

Table 1 shows typical expected jitter tolerance. The following measurements have been done at a transmission rate of T1 (1.544MHz). (See Figure 2).

Jitter	1.544Mbs in UI	Jitter	1.544Mbs in UI
10Hz	>10UI	5kHz	1.3UI
100Hz	>10UI	8kHz	0.8UI
500Hz	>10UI	10kHz	0.7UI
1kHz	6.5UI	32kHz	0.5UI
2kHz	3.3UI	50kHz	0.45UI
3kHz	2.1UI	77kHz	0.45UI
4kHz	1.5UI	-	-

$V_{CC} = +5V \pm 5\%$ ,  $T_A = 25^\circ C$

**Table 1. Jitter Tolerance at 1.544Mbps with 6db Cable Loss**

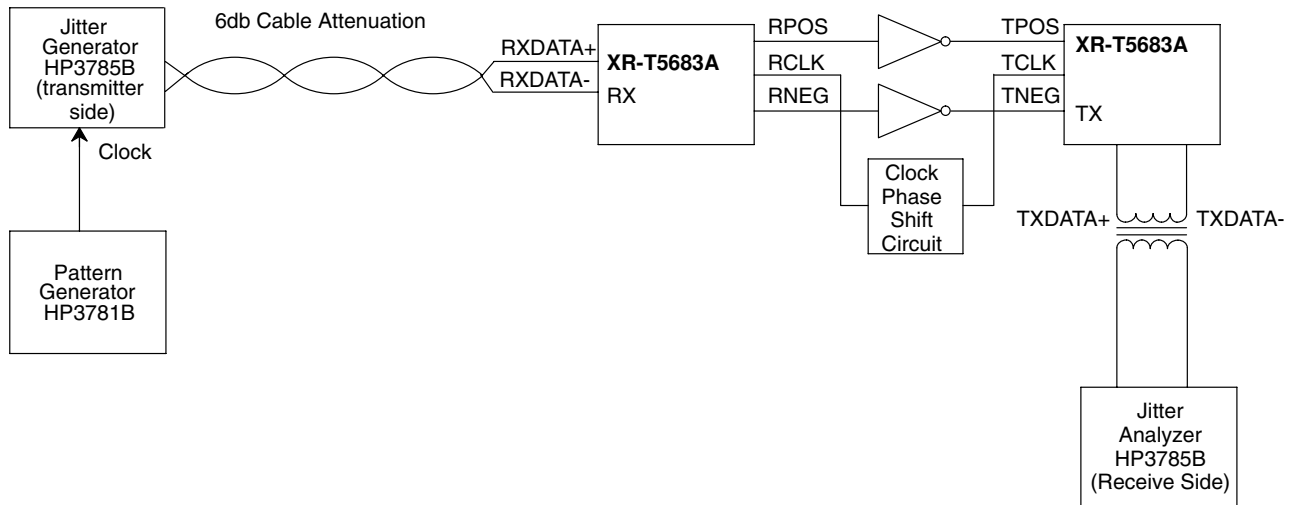

**Figure 2. Jitter Measurement Set-up**

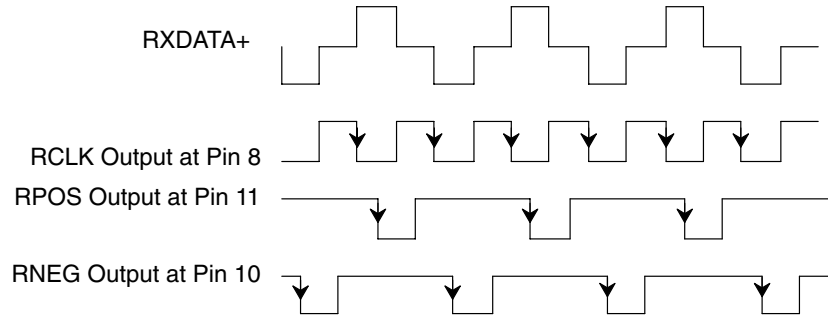

**Figure 3. Receiver Timing Diagram With 1-1-1-1-1 Pattern**

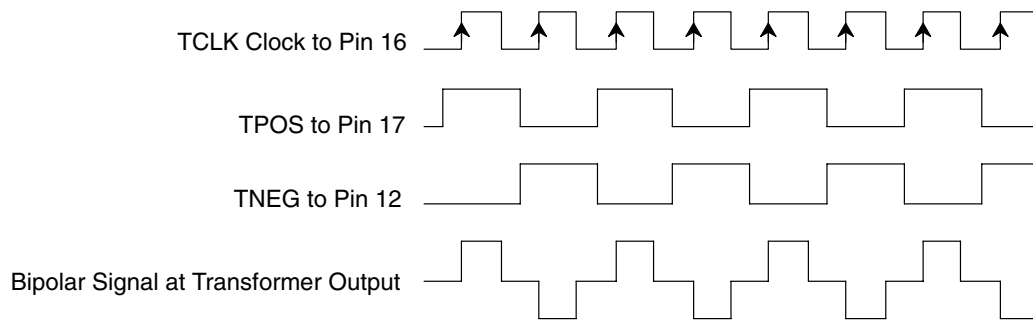

**Figure 4. Transmitter Input Timing Diagram**

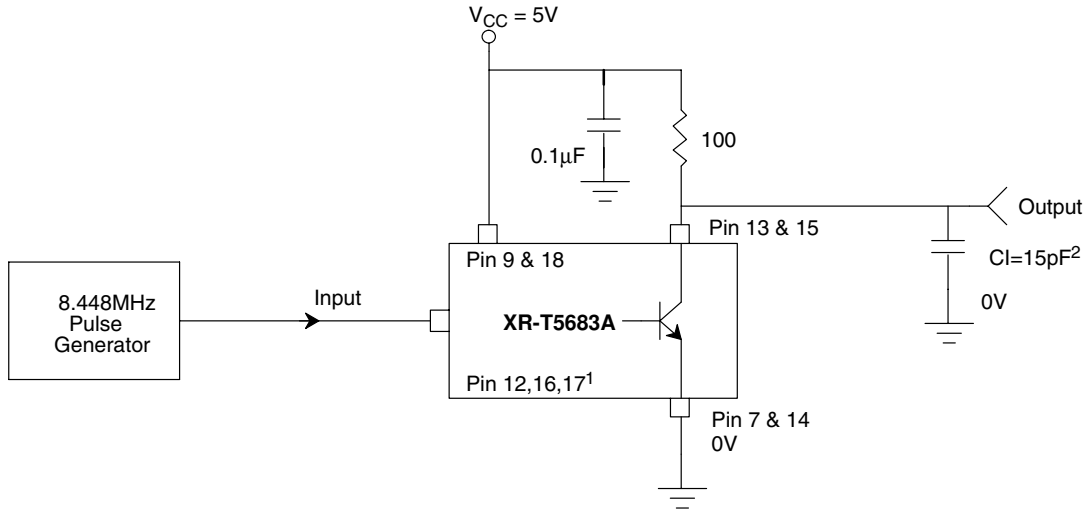

**Notes**

- <sup>1</sup> Inputs that are not connected to pulse generator will be tied to V<sub>CC</sub> via 1K resistor.
- <sup>2</sup> C1 includes probe and jig capacitance.

**Figure 5. Test Circuit**

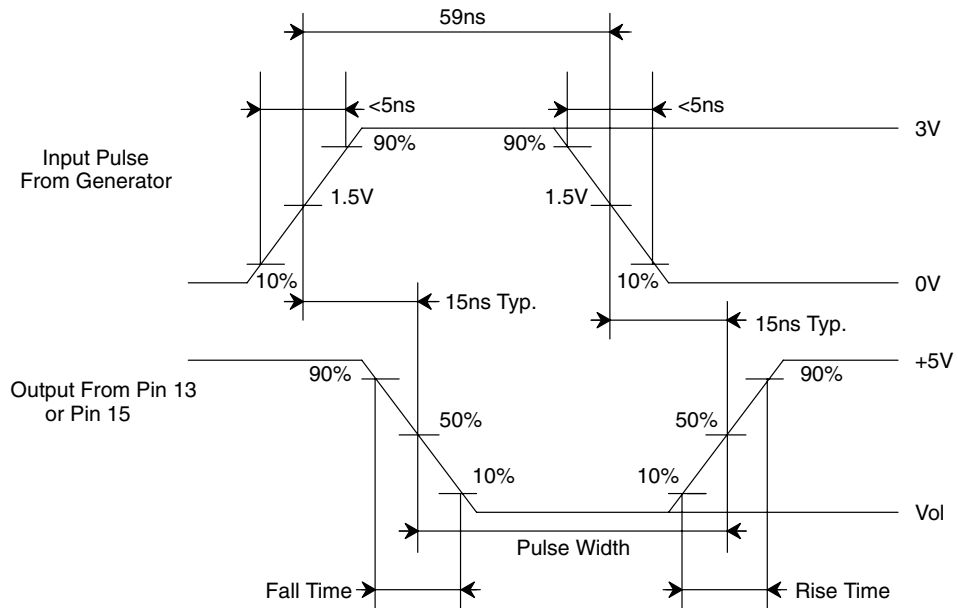

**Figure 6. Transmitter Test Circuit and Switching Waveforms (Measured at 8.448Mbps)**



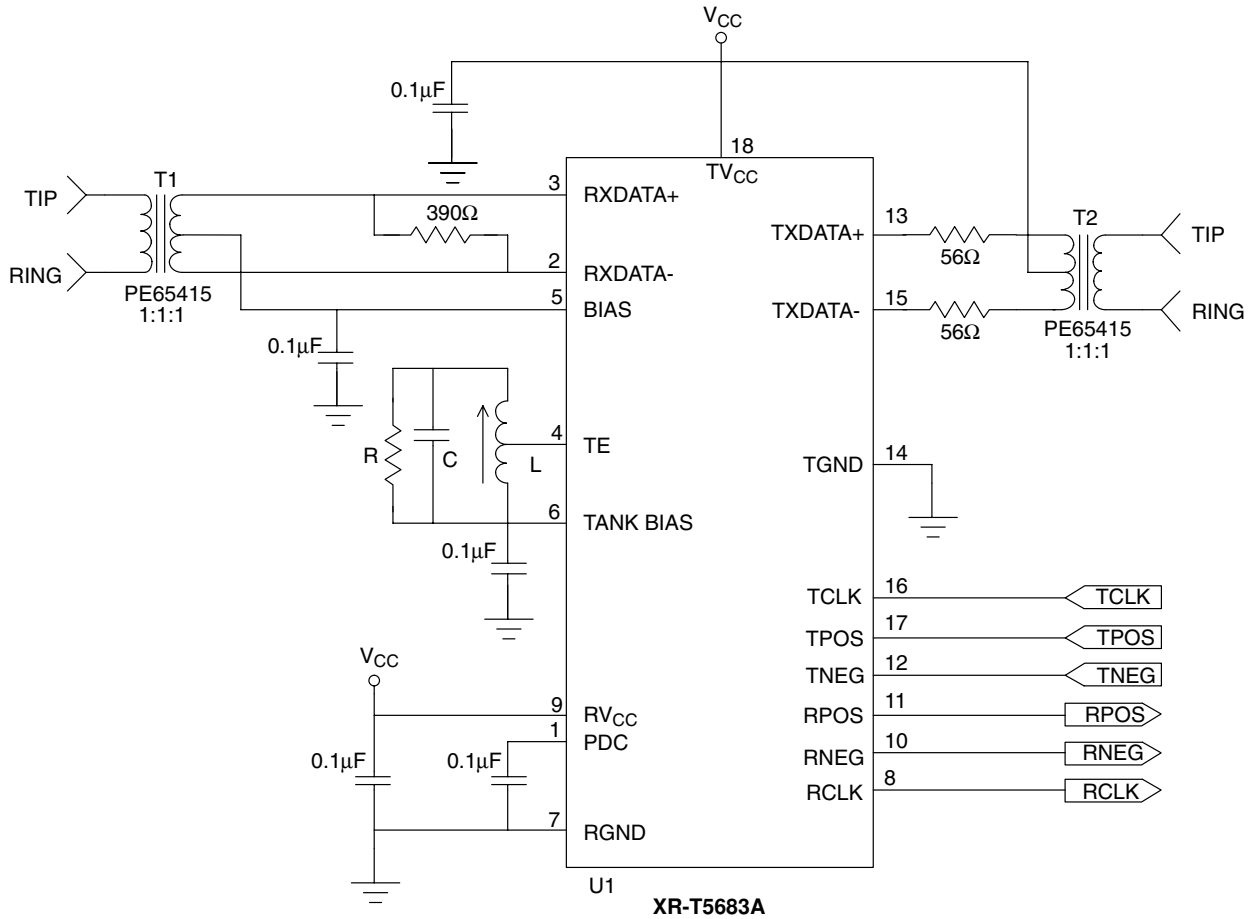

Figure 7. Application Circuit

## INPUT AND OUTPUT TRANSFORMERS

Pulse Engineering types PE-65415, PE-65771 or PE-65835 transformers, may be used for both the input and output transformers. These three parts, which are all 1CT:2CT turns ratio and have similar electrical specifications, are wound on small, epoxy-encapsulated,

torroid cores. They differ in physical size, operating temperature range and voltage isolation. These transformers are suitable for operation over the 1.544 through 8.448Mbps range which includes T1, T2, E1 and E2.

Schott-Part Number	Nominal Inductance	Mechanical Style	Bit Rate (MBIT/S)	Tuning Cap. (See Note)
24443	48μHy with CT	RM 5 Core, 4 Pin Bobbin	1.544(T1)	200pF
			2.048(E1)	100pF
24444	5μHy with CT	14 x 8 Potcore, 6 Pin Bobbin	6.312(T2)	100pF
			6.448(E2)	60pF

**Table 2. Inductor Selection**

### Notes

- Capacitor values shown combined with typical stray capacitance will normally resonate the tank circuit at the specific bit rate.
- The centertapped inductor (L) eliminates clock amplifier overload by reducing the signal amplitude applied to T5683A pin 8 while feeding pseudo-random data into the receive input, tune this inductor for minimum jitter on the recovered clock (pin 8) as shown on an oscilloscope.
- R, which may be in the 20K to 50kΩ range, is optional and may be used to lower clock recovery circuit Q if desired.

### Magnetic Supplier Information:

Pulse  
Telecom Product Group  
P.O. Box 12235  
San Diego, CA 92112  
Tel. (619) 674-8100  
Fax. (619) 674-8262

John Marshall  
Schott Corporation  
1838 Elm Hill Pike, Suite 100  
Nashville, TN 37210  
Tel. (615) 889-8800  
Fax (615) 885-0834

## 18 LEAD PLASTIC DUAL-IN-LINE (300 MIL PDIP)

Rev. 1.00

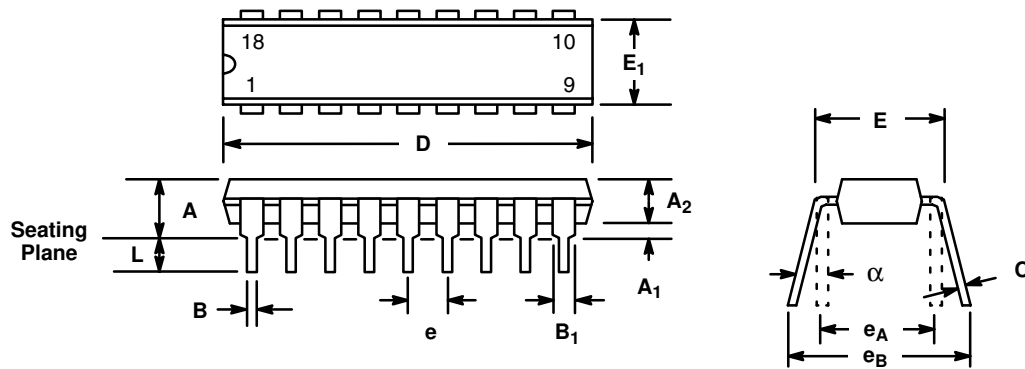

SYMBOL	INCHES		MILLIMETERS	
	MIN	MAX	MIN	MAX
A	0.145	0.210	3.68	5.33
A <sub>1</sub>	0.015	0.070	0.38	1.78
A <sub>2</sub>	0.115	0.195	2.92	4.95
B	0.014	0.024	0.36	0.56
B <sub>1</sub> 0.030		0.070	0.76	1.78
C	0.008	0.014	0.20	0.38
D	0.845	0.925	21.46	23.50
E	0.300	0.325	7.62	8.26
E <sub>1</sub>	0.240	0.280	6.10	7.11
e	0.100 BSC		2.54 BSC	
e <sub>A</sub>	0.300 BSC		7.62 BSC	
e <sub>B</sub>	0.310	0.430	7.87	10.92
L	0.115	0.160	2.92	4.06
α	0°	15°	0°	15°

Note: The control dimension is the inch column

**18 LEAD SMALL OUTLINE  
(300 MIL JEDEC SOIC)**

*Rev. 1.00*

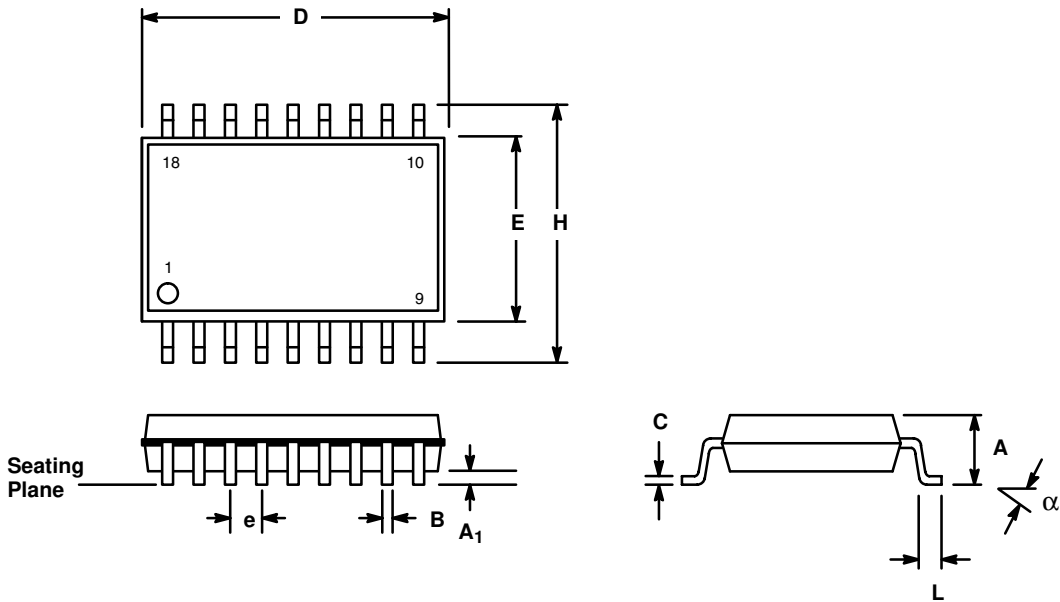

SYMBOL	INCHES		MILLIMETERS	
	MIN	MAX	MIN	MAX
A	0.093	0.104	2.35	2.65
A <sub>1</sub>	0.004	0.012	0.10	0.30
B	0.013	0.020	0.33	0.51
C	0.009	0.013	0.23	0.32
D	0.447	0.463	11.35	11.75
E	0.291	0.299	7.40	7.60
e	0.050 BSC		1.27 BSC	
H	0.394	0.419	10.00	10.65
L	0.016	0.050	0.40	1.27
α	0°	8°	0°	8°

*Note: The control dimension is the millimeter column*

## NOTICE

EXAR Corporation reserves the right to make changes to the products contained in this publication in order to improve design, performance or reliability. EXAR Corporation assumes no responsibility for the use of any circuits described herein, conveys no license under any patent or other right, and makes no representation that the circuits are free of patent infringement. Charts and schedules contained herein are only for illustration purposes and may vary depending upon a user's specific application. While the information in this publication has been carefully checked; no responsibility, however, is assumed for inaccuracies.

EXAR Corporation does not recommend the use of any of its products in life support applications where the failure or malfunction of the product can reasonably be expected to cause failure of the life support system or to significantly affect its safety or effectiveness. Products are not authorized for use in such applications unless EXAR Corporation receives, in writing, assurances to its satisfaction that: (a) the risk of injury or damage has been minimized; (b) the user assumes all such risks; (c) potential liability of EXAR Corporation is adequately protected under the circumstances.

Copyright 2010 EXAR Corporation  
Datasheet October 2010

Reproduction, in part or whole, without the prior written consent of EXAR Corporation is prohibited.