



Chipsmall Limited consists of a professional team with an average of over 10 year of expertise in the distribution of electronic components. Based in Hongkong, we have already established firm and mutual-benefit business relationships with customers from,Europe,America and south Asia,supplying obsolete and hard-to-find components to meet their specific needs.

With the principle of "Quality Parts,Customers Priority,Honest Operation,and Considerate Service",our business mainly focus on the distribution of electronic components. Line cards we deal with include Microchip,ALPS,ROHM,Xilinx,Pulse,ON,Everlight and Freescale. Main products comprise IC,Modules,Potentiometer,IC Socket,Relay,Connector.Our parts cover such applications as commercial,industrial, and automotives areas.

We are looking forward to setting up business relationship with you and hope to provide you with the best service and solution. Let us make a better world for our industry!



Contact us

Tel: +86-755-8981 8866 Fax: +86-755-8427 6832

Email & Skype: info@chipsmall.com Web: www.chipsmall.com

Address: A1208, Overseas Decoration Building, #122 Zhenhua RD., Futian, Shenzhen, China



GENERAL DESCRIPTION

The XRT86VL30 is a single channel 1.544 Mbit/s or 2.048 Mbit/s DS1/E1/J1 framer and LIU integrated solution featuring R³ technology (Relayless, Reconfigurable, Redundancy). The physical interface is optimized with internal impedance, and with the patented pad structure, the XRT86VL30 provides protection from power failures and hot swapping.

The XRT86VL30 contains an integrated DS1/E1/J1 framer and LIU which provides DS1/E1/J1 framing and error accumulation in accordance with ANSI/ITU_T specifications. The framer has its own framing synchronizer and transmit-receive slip buffers. The slip buffers can be independently enabled or disabled as required and can be configured to frame to the common DS1/E1/J1 signal formats.

The Framer block contains its own Transmit and Receive T1/E1/J1 Framing function. There are 3 Transmit HDLC controllers which encapsulate contents of the Transmit HDLC buffers into LAPD Message frames. There are 3 Receive HDLC controllers which extract the payload content of

Receive LAPD Message frames from the incoming T1/E1/J1 data stream and write the contents into the Receive HDLC buffers. The framer also contains a Transmit and Overhead Data Input port, which permits Data Link Terminal Equipment direct access to the outbound T1/E1/J1 frames. Likewise, a Receive Overhead output data port permits Data Link Terminal Equipment direct access to the Data Link bits of the inbound T1/E1/J1 frames.

The XRT86VL30 fully meets all of the latest T1/E1/J1 specifications: ANSI T1/E1.107-1988, ANSI T1/E1.403-1995, ANSI T1/E1.231-1993, ANSI T1/E1.408-1990, AT&T TR 62411 (12-90) TR54016, and ITU G-703, G.704, G.706 and G.733, AT&T Pub. 43801, and ETS 300 011, 300 233, JT G.703, JT G.704, JT G.706, I.431. Extensive test and diagnostic functions include Loop-backs, Boundary scan, Pseudo Random bit sequence (PRBS) test pattern generation, Performance Monitor, Bit Error Rate (BER) meter, forced error insertion, and LAPD unchannelized data payload processing according to ITU-T standard Q.921.

APPLICATIONS AND FEATURES (NEXT PAGE)

FIGURE 1. XRT86VL30 SINGLE CHANNEL DS1 (T1/E1/J1) FRAMER/LIU COMBO

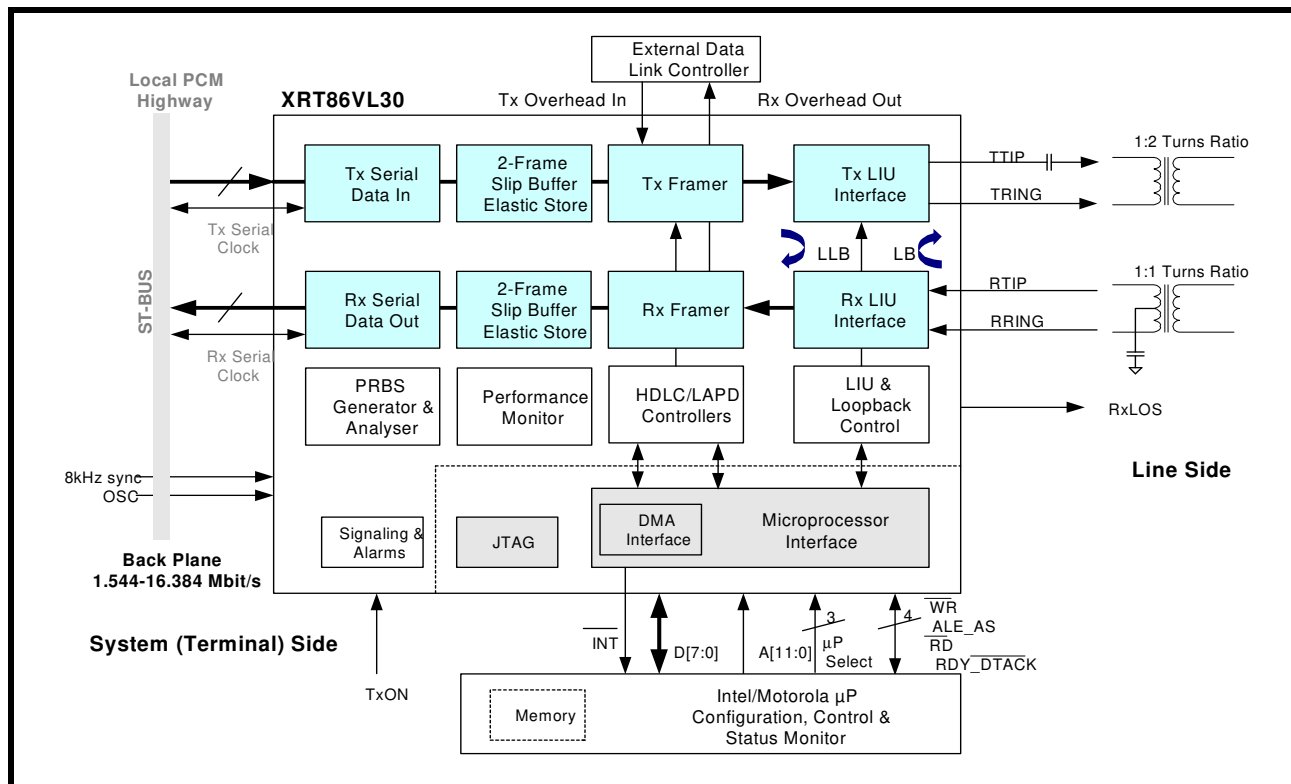

APPLICATIONS

- High-Density T1/E1/J1 interfaces for Multiplexers, Switches, LAN Routers and Digital Modems
- SONET/SDH terminal or Add/Drop multiplexers (ADMs)
- T1/E1/J1 add/drop multiplexers (MUX)
- Channel Service Units (CSUs): T1/E1/J1 and Fractional T1/E1/J1
- Digital Access Cross-connect System (DACs)
- Digital Cross-connect Systems (DCS)
- Frame Relay Switches and Access Devices (FRADS)
- ISDN Primary Rate Interfaces (PRA)
- PBXs and PCM channel bank
- T3 channelized access concentrators and M13 MUX
- Wireless base stations
- ATM equipment with integrated DS1 interfaces
- Multichannel DS1 Test Equipment
- T1/E1/J1 Performance Monitoring
- Voice over packet gateways
- Routers

FEATURES

- Supports SSM Synchronization Messaging per ANSI T1.101-1999 and ITU G.704
- Supports a Customized Section 13 - Synchronization Interface in G.703 at 1.544MHz
- Independent, full duplex DS1 Tx and Rx Framer/LIUs
- Two 512-bit (two-frame) elastic store, PCM frame slip buffers (FIFO) on TX and Rx provide up to 8.192 MHz asynchronous back plane connections with jitter and wander attenuation
- Supports input PCM and signaling data at 1.544, 2.048, 4.096 and 8.192 Mbits. Also supports 2-channel multiplexed 12.352/16.384 (HMVIP/H.100) Mbit/s on the back plane bus
- Programmable output clocks for Fractional T1/E1/J1
- Supports Channel Associated Signaling (CAS)
- Supports Common Channel Signalling (CCS)
- Supports ISDN Primary Rate Interface (ISDN PRI) signaling
- Extracts and inserts robbed bit signaling (RBS)
- 3 Integrated HDLC controllers for transmit and receive, each controller having two 96-byte buffers (buffer 0 / buffer 1)
- HDLC Controllers Support SS7
- Timeslot assignable HDLC
- V5.1 or V5.2 Interface
- Automatic Performance Report Generation (PMON Status) can be inserted into the transmit LAPD interface every 1 second or for a single transmission
- Alarm Indication Signal with Customer Installation signature (AIS-CI)



- Remote Alarm Indication with Customer Installation (RAI-CI)
- Gapped Clock interface mode for Transmit and Receive.
- Intel/Motorola and Power PC interfaces for configuration, control and status monitoring
- Parallel search algorithm for fast frame synchronization
- Wide choice of T1 framing structures: SF/D4, ESF, SLC@96, T1DM and N-Frame (non-signaling)
- Direct access to D and E channels for fast transmission of data link information
- PRBS, QRSS, and Network Loop Code generation and detection
- Programmable Interrupt output pin
- Supports programmed I/O and DMA modes of Read-Write access
- The framer block encodes and decodes the T1/E1/J1 Frame serial data
- Detects and forces Red (SAI), Yellow (RAI) and Blue (AIS) Alarms
- Detects OOF, LOF, LOS errors and COFA conditions
- Loopbacks: Local (LLB) and Line remote (LB)
- Facilitates Inverse Multiplexing for ATM
- Performance monitor with one second polling
- Boundary scan (IEEE 1149.1) JTAG test port
- Accepts external 8kHz Sync reference
- 1.8V Inner Core
- 3.3V CMOS operation with 5V tolerant inputs
- 128-pin LQFP and 80-pin LQFP package with -40°C to +85°C operation

ORDERING INFORMATION

PART NUMBER	PACKAGE	OPERATING TEMPERATURE RANGE
XRT86VL30IV	128 Pin LQFP(14x20x1.4mm)	-40°C to +85°C
XRT86VL30IV80	80 Pin LQFP (12x12x1.4mm)	-40°C to +85°C

LIST OF PARAGRAPHS

1.0 REGISTER DESCRIPTIONS - T1 MODE9
2.0 LINE INTERFACE UNIT (LIU SECTION) REGISTERS142



LIST OF FIGURES

Figure 1.: XRT86VL30 Single Channel DS1 (T1/E1/J1) Framer/LIU Combo 1

LIST OF TABLES

Table 1:: Register Summary	4
Table 2:: Clock Select Register(CSR)	9
Table 3:: Line Interface Control Register (LICR)	11
Table 4:: General Purpose Input/Output Control Register (GPIOCR)	13
Table 5:: Framing Select Register (FSR)	14
Table 6:: Alarm Generation Register (AGR)	16
Table 7:: yellow alarm duration and format when one second rule is not enforced	17
Table 8:: yellow alarm format when one second rule is enforced	18
Table 9:: Synchronization MUX Register (SMR)	20
Table 10:: Transmit Signaling and Data Link Select Register (TSDLSR)	23
Table 11:: Framing Control Register (FCR)	25
Table 12:: Receive Signaling & Data Link Select Register (RSDLSR)	26
Table 13:: Receive Signaling Change Register 0 (RSCR 0)	28
Table 14:: Receive Signaling Change Register 1(RSCR 1)	28
Table 15:: Receive Signaling Change Register 2 (RSCR 2)	28
Table 16:: Receive In Frame Register (RIFR)	29
Table 17:: Data Link Control Register (DLCR1)	29
Table 18:: Transmit Data Link Byte Count Register (TDLBCR1)	32
Table 19:: Receive Data Link Byte Count Register (RDLBCR1)	33
Table 20:: Slip Buffer Control Register (SBCR)	34
Table 21:: FIFO Latency Register (FFOLR)	35
Table 22:: DMA 0 (Write) Configuration Register (D0WCR)	36
Table 23:: DMA 1 (Read) Configuration Register (D1RCR)	37
Table 24:: Interrupt Control Register (ICR)	38
Table 25:: LAPD Select Register (LAPDSR)	38
Table 26:: Customer Installation Alarm Generation Register (CIAGR)	39
Table 27:: Performance Report Control Register (PRCR)	40
Table 28:: Gapped Clock Control Register (GCCR)	41
Table 29:: Transmit Interface Control Register (TICR)	42
Table 30:: Transmit Interface Speed When Multiplexed Mode is Disabled (TxMUXEN = 0)	44
Table 31:: Transmit Interface Speed when Multiplexed Mode is Enabled (TxMUXEN = 1)	45
Table 32:: BERT Control & Status Register (BERTCSR0)	46
Table 33:: Receive Interface Control Register (RICR)	48
Table 34:: Receive Interface Speed When Multiplexed Mode is Disabled (TxMUXEN = 0)	50
Table 35:: Receive Interface Speed when Multiplexed Mode is Enabled (TxMUXEN = 1)	51
Table 36:: BERT Control & Status Register (BERTCSR1)	52
Table 37:: Loopback Code Control Register - Code 0 (LCCR0)	54
Table 38:: Transmit Loopback Coder Register (TLCR)	56
Table 39:: Receive Loopback Activation Code Register - Code 0 (RLACR0)	56
Table 40:: Receive Loopback Deactivation Code Register - Code 0 (RLDCR0)	56
Table 41:: Defect Detection Enable Register (DDER)	57
Table 42:: Loopback Code Control Register - Code 1 (LCCR1)	57
Table 43:: Receive Loopback Activation Code Register - Code 1 (RLACR1)	59
Table 44:: Receive Loopback Deactivation Code Register - Code 1 (RLDCR1)	59
Table 45:: Loopback Code Control Register - Code 2 (LCCR2)	60
Table 46:: Receive Loopback Activation Code Register - Code 2 (RLACR2)	62
Table 47:: Receive Loopback Deactivation Code Register - Code 2 (RLDCR2)	62
Table 48:: Transmit SPRM and NPRM Control Register (TSPRMCR)	63
Table 49:: Data Link Control Register (DLCR2)	64
Table 50:: Transmit Data Link Byte Count Register (TDLBCR2)	66
Table 51:: Receive Data Link Byte Count Register (RDLBCR2)	67
Table 52:: Data Link Control Register (DLCR3)	68
Table 53:: Transmit Data Link Byte Count Register (TDLBCR3)	70
Table 54:: Receive Data Link Byte Count Register (RDLBCR3)	71
Table 55:: BERT Control Register (BCR)	72
Table 56:: T1 SSM Messages	73
Table 57:: SSM BOC Control Register (BOCCR 0x0170h)	74
Table 58:: SSM Receive FDL Register (RFDLR 0x0171h)	75



Table 59:: SSM Receive FDL Match 1 Register (RFDLMR1 0x0172h)	76
Table 60:: SSM Receive FDL Match 2 Register (RFDLMR2 0x0173h)	76
Table 61:: SSM Receive FDL Match 3 Register (RFDLMR3 0x0174h)	76
Table 62:: SSM Transmit FDL Register (TFDLR 0x0175h)	77
Table 63:: SSM Transmit Byte Count Register (TBCR 0x0176h)	77
Table 64:: Device ID Register (DEVID)	Hex Address: 0x01FE 78
Table 65:: Revision ID Register (REVID)	Hex Address: 0x01FF 78
Table 66:: Transmit Channel Control Register 0-23 (TCCR 0-23)	Hex Address: 0x0300 to 0x0317 79
Table 67:: Transmit User Code Register 0-23 (TUCR 0-23)	Hex Address: 0x0320 to 0x0337 81
Table 68:: Transmit Signaling Control Register 0-23 (TSCR 0-23)	Hex Address: 0x0340 to 0x0357 82
Table 69:: Receive Channel Control Register 0-23 (RCCR 0-23)	Hex Address: 0x0360 to 0x0377 84
Table 70:: Receive User Code Register 0-23 (RUCR 0-23)	Hex Address: 0x0380 to 0x0397 86
Table 71:: Receive Signaling Control Register 0-23 (RSCR 0-23)	Hex Address: 0x03A0 to 0x03B7 87
Table 72:: Receive Substitution Signaling Register 0-23 (RSSR 0-23)	Hex Address: 0x03C0 to 0x03D7 89
Table 73:: Receive Signaling Array Register 0 to 23 (RSAR 0-23)	Hex Address: 0x0500 to 0x0517 90
Table 74:: LAPD Buffer 0 Control Register (LAPDBCRO)	Hex Address: 0x0600 91
Table 75:: LAPD Buffer 1 Control Register (LAPDBCRI)	Hex Address: 0x0700 91
Table 76:: PMON Receive Line Code Violation Counter MSB (RLCVCU)	Hex Address: 0x0900 92
Table 77:: PMON Receive Line Code Violation Counter LSB (RLCVCL)	Hex Address: 0x0901 92
Table 78:: PMON Receive Framing Alignment Bit Error Counter MSB (RFAECU)	Hex Address: 0x0902 93
Table 79:: PMON Receive Framing Alignment Bit Error Counter LSB (RFAECL)	Hex Address: 0x0903 93
Table 80:: PMON Receive Severely Errored Frame Counter (RSEFC)	Hex Address: 0x0904 94
Table 81:: PMON Receive CRC-6 BIT Error Counter - MSB (RSBBECU)	Hex Address: 0x0905 95
Table 82:: PMON Receive CRC-6 Bit Error Counter - LSB (RSBBECL)	Hex Address: 0x0906 95
Table 83:: PMON Receive Slip Counter (RSC)	Hex Address: 0x0909 96
Table 84:: PMON Receive Loss of Frame Counter (RLFC)	Hex Address: 0x090A 96
Table 85:: PMON Receive Change of Frame Alignment Counter (RCFAC)	Hex Address: 0x090B 96
Table 86:: PMON LAPD1 Frame Check Sequence Error Counter 1 (LFCSEC1)	Hex Address: 0x090C 97
Table 87:: PRBS Bit Error Counter MSB (PBEUC)	Hex Address: 0x090D 97
Table 88:: PRBS Bit Error Counter LSB (PBECL)	Hex Address: 0x090E 97
Table 89:: Transmit Slip Counter (TSC)	Hex Address: 0x090F 98
Table 90:: Excessive Zero Violation Counter MSB (EZVCU)	Hex Address: 0x0910 98
Table 91:: Excessive Zero Violation Counter LSB (EZVCL)	Hex Address: 0x0911 98
Table 92:: PMON LAPD2 Frame Check Sequence Error Counter 2 (LFCSEC2)	Hex Address: 0x091C 99
Table 93:: PMON LAPD2 Frame Check Sequence Error Counter 3 (LFCSEC3)	Hex Address: 0x092C 99
Table 94:: Block Interrupt Status Register (BISR)	Hex Address: 0x0B00 100
Table 95:: Block Interrupt Enable Register (BIER)	Hex Address: 0x0B01 102
Table 96:: Alarm & Error Interrupt Status Register (AEISR)	Hex Address: 0x0B02 104
Table 97:: Alarm & Error Interrupt Enable Register (AEIER)	Hex Address: 0x0B03 106
Table 98:: Framer Interrupt Status Register (FISR)	Hex Address: 0x0B04 107
Table 99:: Framer Interrupt Enable Register (FIER)	Hex Address: 0x0B05 109
Table 100:: Data Link Status Register 1 (DLSR1)	Hex Address: 0x0B06 111
Table 101:: Data Link Interrupt Enable Register 1 (DLIER1)	Hex Address: 0x0B07 113
Table 102:: Slip Buffer Interrupt Status Register (SBISR)	Hex Address: 0x0B08 115
Table 103:: Slip Buffer Interrupt Enable Register (SBIER)	Hex Address: 0x0B09 118
Table 104:: Receive Loopback Code Interrupt and Status Register (RLCISR)	Hex Address: 0x0B0A 120
Table 105:: Receive Loopback Code Interrupt Enable Register (RLCIER)	Hex Address: 0x0B0B 121
Table 106:: Excessive Zero Status Register (EXZSR)	Hex Address: 0x0B0E 122
Table 107:: Excessive Zero Enable Register (EXZER)	Hex Address: 0x0B0F 122
Table 108:: SS7 Status Register for LAPD1 (SS7SR1)	Hex Address: 0x0B10 123
Table 109:: SS7 Enable Register for LAPD1 (SS7ER1)	Hex Address: 0x0B11 123
Table 110:: RxLOS/CRC Interrupt Status Register (RLCISR)	Hex Address: 0x0B12 124
Table 111:: RxLOS/CRC Interrupt Enable Register (RLCIER)	Hex Address: 0x0B13 124
Table 112:: Data Link Status Register 2 (DLSR2)	Hex Address: 0x0B16 125
Table 113:: Data Link Interrupt Enable Register 2 (DLIER2)	Hex Address: 0x0B17 127
Table 114:: SS7 Status Register for LAPD2 (SS7SR2)	Hex Address: 0x0B18 129
Table 115:: SS7 Enable Register for LAPD2 (SS7ER2)	Hex Address: 0x0B19 129
Table 116:: Data Link Status Register 3 (DLSR3)	Hex Address: 0x0B26 130
Table 117:: Data Link Interrupt Enable Register 3 (DLIER3)	Hex Address: 0x0B27 132
Table 118:: SS7 Status Register for LAPD3 (SS7SR3)	Hex Address: 0x0B28 134

SINGLE T1/E1/J1 FRAMER/LIU COMBO - T1 REGISTER DESCRIPTION

Table 119:: SS7 Enable Register for LAPD3 (SS7ER3)	Hex Address: 0x0B29	134
Table 120:: Customer Installation Alarm Status Register (CIASR)	Hex Address: 0x0B40	135
Table 121:: Customer Installation Alarm Status Register (CIAIER)	Hex Address: 0x0B41	136
Table 122:: T1 BOC Interrupt Status Register (BOCISR 0x0B70h)		137
Table 123:: T1 BOC Interrupt Enable Register (BOCIER 0x0B71h)		139
Table 124:: T1 BOC Unstable Interrupt Status Register (BOCUIISR 0x0B74h)		140
Table 125:: T1 BOC Unstable Interrupt Enable Register (BOCUIER 0x0B75h)		141
Table 126:: LIU Channel Control Register 0 (LIUCCR0)	Hex Address: 0x0F00	142
Table 127:: Equalizer Control and Transmit Line Build Out		144
Table 128:: LIU Channel Control Register 1 (LIUCCR1)	Hex Address: 0x0F01	145
Table 129:: LIU Channel Control Register 2 (LIUCCR2)	Hex Address: 0x0F02	147
Table 130:: LIU Channel Control Register 3 (LIUCCR3)	Hex Address: 0x0F03	149
Table 131:: LIU Channel Control Interrupt Enable Register (LIUCCIER)	Hex Address: 0x0F04	151
Table 132:: LIU Channel Control Status Register (LIUCCSR)	Hex Address: 0x0F05	153
Table 133:: LIU Channel Control Interrupt Status Register (LIUCCISR)	Hex Address: 0x0F06	156
Table 134:: LIU Channel Control Cable Loss Register (LIUCCCLR)	Hex Address: 0x0F07	158
Table 135:: LIU Channel Control Arbitrary Register 1 (LIUCCAR1)	Hex Address: 0x0F08	158
Table 136:: LIU Channel Control Arbitrary Register 2 (LIUCCAR2)	Hex Address: 0x0F09	158
Table 137:: LIU Channel Control Arbitrary Register 3 (LIUCCAR3)	Hex Address: 0x0F0A	159
Table 138:: LIU Channel Control Arbitrary Register 4 (LIUCCAR4)	Hex Address: 0x0F0B	159
Table 139:: LIU Channel Control Arbitrary Register 5 (LIUCCAR5)	Hex Address: 0x0F0C	159
Table 140:: LIU Channel Control Arbitrary Register 6 (LIUCCAR6)	Hex Address: 0x0F0D	160
Table 141:: LIU Channel Control Arbitrary Register 7 (LIUCCAR7)	Hex Address: 0x0F0E	160
Table 142:: LIU Channel Control Arbitrary Register 8 (LIUCCAR8)	Hex Address: 0x0F0F	160
Table 143:: LIU Global Control Register 0 (LIUGCR0)	Hex Address: 0x0FE0	161
Table 144:: LIU Global Control Register 1 (LIUGCR1)	Hex Address: 0x0FE1	163
Table 145:: LIU Global Control Register 2 (LIUGCR2)	Hex Address: 0x0FE2	164
Table 146:: LIU Global Control Register 3 (LIUGCR3)	Hex Address: 0x0FE4	165
Table 147:: LIU Global Control Register 4 (LIUGCR4)	Hex Address: 0x0FE9	166
Table 148:: LIU Global Control Register 5 (LIUGCR5)	Hex Address: 0x0FEA	167



DESCRIPTION OF THE CONTROL REGISTERS - T1 MODE

All address on this register description is shown in HEX format.

TABLE 1: REGISTER SUMMARY

FUNCTION	SYMBOL	HEX
Control Registers (0x0100 - 0x01FF)		
Clock and Select Register	CSR	0x0100
Line Interface Control Register	LICR	0x0101
GPIO Control Register	GPIOCR	0x0102
Reserved	-	0x0103 - 0x0106
Framing Select Register	FSR	0x0107
Alarm Generation Register	AGR	0x0108
Synchronization MUX Register	SMR	0x0109
Transmit Signaling and Data Link Select Register	TSDLSR	0x010A
Framing Control Register	FCR	0x010B
Receive Signaling & Data Link Select Register	RSDLSR	0x010C
Receive Signaling Change Register 0	RSCR0	0x010D
Receive Signaling Change Register 1	RSCR1	0x010E
Receive Signaling Change Register 2	RSCR2	0x010F
Reserved - E1 mode only	-	0x0110 - 0x0111
Receive In-Frame Register	RIFR	0x0112
Data Link Control Register 1	DLCR1	0x0113
Transmit Data Link Byte Count Register 1	TDLBCR1	0x0114
Receive Data Link Byte Count Register 1	RDLBCR1	0x0115
Slip Buffer Control Register	SBCR	0x0116
FIFO Latency Register	FIFOLR	0x0117
DMA 0 (Write) Configuration Register	D0WCR	0x0118
DMA 1 (Read) Configuration Register	D1RCR	0x0119
Interrupt Control Register	ICR	0x011A
LAPD Select Register	LAPDSR	0x011B
Customer Installation Alarm Generation Register	CIAGR	0x011C
Performance Report Control Register	PRCR	0x011D
Gapped Clock Control Register	GCCR	0x011E
Transmit Interface Control Register	TICR	0x0120
BERT Control & Status - Register 0	BERTCSR0	0x0121

TABLE 1: REGISTER SUMMARY

FUNCTION	SYMBOL	HEX
Receive Interface Control Register	RICR	0x0122
BERT Control & Status - Register 1	BERTCSR1	0x0123
Loopback Code Control Register - Code 0	LCCR0	0x0124
Transmit Loopback Code Register	TLCR	0x0125
Receive Loopback Activation Code Register - Code 0	RLACR0	0x0126
Receive Loopback Deactivation Code Register - Code 0	RLDCR0	0x0127
Defect Detection Enable Register	DDER	0x0129
Loopback Code Control Register - Code 1	LCCR1	0x012A
Receive Loopback Activation Code Register - Code 1	RLACR1	0x012B
Receive Loopback Deactivation Code Register - Code 1	RLDCR1	0x012C
Loopback Code Control Register - Code 2	LCCR2	0x012D
Receive Loopback Activation Code Register - Code 2	RLACR2	0x012E
Receive Loopback Deactivation Code Register - Code 2	RLDCR2	0x012F
Reserved - E1 mode only	-	0x0130 - 0x013F
Transmit SPRM and NPRM Control Register	TSPRMCR	0x0142
Data Link Control Register 2	DLCR2	0x0143
Transmit Data Link Byte Count Register 2	TDLBCR2	0x0144
Receive Data Link Byte Count Register 2	RDLBCR2	0x0145
Data Link Control Register 3	DLCR3	0x0153
Transmit Data Link Byte Count Register 3	TDLBCR3	0x0154
Receive Data Link Byte Count Register 3	RDLBCR3	0x0155
BERT Control Register	BCR	0x0163
SSM BOC Control Register	BOCCR	0x0170
SSM Receive FDL Register	RFDLR	0x0171
SSM Receive FDL Match 1 Register	RFDLMR1	0x0172
SSM Receive FDL Match 2 Register	RFDLMR2	0x0173
SSM Receive FDL Match 3 Register	RFDLMR3	0x0174
SSM Transmit FDL Register	TFDLR	0x0175
SSM Transmit Byte Count Register	TBCR	0x0176
Device ID Register	DEVID	0x01FE
Revision Number Register	REVID	0x01FF
Time Slot (payload) Control (0x0300 - 0x03FF)		
Transmit Channel Control Register 0-23	TCCR 0-23	0x0300 - 0x0317

TABLE 1: REGISTER SUMMARY

FUNCTION	SYMBOL	HEX
Transmit User Code Register 0-23	TUCR 0-23	0x0320 - 0x0337
Transmit Signaling Control Register 0-23	TSCR 0-23	0x0340 - 0x0357
Receive Channel Control Register 0-23	RCCR 0-23	0x0360 - 0x0377
Receive User Code Register 0-23	RUCR 0-23	0x0380 - 0x0397
Receive Signaling Control Register 0-23	RSCR 0-23	0x03A0 - 0x03B7
Receive Substitution Signaling Register 0-23	RSSR 0-23	0x03C0 - 0x03D7
Receive Signaling Array (0x0500 - 0x051F)		
Receive Signaling Array Register 0	RSAR0-23	0x0500 - 0x0517
LAPDn Buffer 0		
LAPD Buffer 0 Control Register	LAPDBCRO	0x0600 - 0x0660
LAPDn Buffer 1		
LAPD Buffer 1 Control Register	LAPDBCRI	0x0700 - 0x0760
Performance Monitor		
Receive Line Code Violation Counter: MSB	RLCVCU	0x0900
Receive Line Code Violation Counter: LSB	RLCVCL	0x0901
Receive Frame Alignment Error Counter: MSB	RFAECU	0x0902
Receive Frame Alignment Error Counter: LSB	RFAECL	0x0903
Receive Severely Errored Frame Counter	RSEFC	0x0904
Receive Synchronization Bit (CRC-6) Error Counter: MSB	RSBBECU	0x0905
Receive Synchronization Bit (CRC-6) Error Counter: LSB	RSBBECL	0x0906
Reserved - E1 Mode Only		0x0907 - 0x0908
Receive Slip Counter	RSC	0x0909
Receive Loss of Frame Counter	RLFC	0x090A
Receive Change of Frame Alignment Counter	RCOAC	0x090B
LAPD Frame Check Sequence Error counter 1	LFCSEC1	0x090C
PRBS bit Error Counter: MSB	PBECU	0x090D
PRBS bit Error Counter: LSB	PBECL	0x090E
Transmit Slip Counter	TSC	0x090F
Excessive Zero Violation Counter: MSB	EZVCU	0x0910
Excessive Zero Violation Counter: LSB	EZVCL	0x0911
LAPD Frame Check Sequence Error counter 2	LFCSEC2	0x091C

TABLE 1: REGISTER SUMMARY

FUNCTION	SYMBOL	HEX
LAPD Frame Check Sequence Error counter 3	LFCSEC3	0x092C
Interrupt Generation/Enable Register Address Map (0x0B00 - 0x0B41)		
Block Interrupt Status Register	BISR	0x0B00
Block Interrupt Enable Register	BIER	0x0B01
Alarm & Error Interrupt Status Register	AEISR	0x0B02
Alarm & Error Interrupt Enable Register	AEIER	0x0B03
Framer Interrupt Status Register	FISR	0x0B04
Framer Interrupt Enable Register	FIER	0x0B05
Data Link Status Register 1	DLSR1	0x0B06
Data Link Interrupt Enable Register 1	DLIER1	0x0B07
Slip Buffer Interrupt Status Register	SBISR	0x0B08
Slip Buffer Interrupt Enable Register	SBIER	0x0B09
Receive Loopback code Interrupt and Status Register	RLCISR	0x0B0A
Receive Loopback code Interrupt Enable Register	RLCIER	0x0B0B
Reserved - E1 Mode Only	-	0x0B0C - 0x0B0D
Excessive Zero Status Register	EXZSR	0x0B0E
Excessive Zero Enable Register	EXZER	0x0B0F
SS7 Status Register for LAPD 1	SS7SR1	0x0B10
SS7 Enable Register for LAPD 1	SS7ER1	0x0B11
RxLOS/CRC Interrupt Status Register	RLCISR	0x0B12
RxLOS/CRC Interrupt Enable Register	RLCIER	0x0B13
Data Link Status Register 2	DLSR2	0x0B16
Data Link Interrupt Enable Register 2	DLIER2	0x0B17
SS7 Status Register for LAPD 2	SS7SR2	0x0B18
SS7 Enable Register for LAPD 2	SS7ER2	0x0B19
Data Link Status Register 3	DLSR3	0x0B26
Data Link Interrupt Enable Register 3	DLIER3	0x0B27
SS7 Status Register for LAPD 3	SS7SR3	0x0B28
SS7 Enable Register for LAPD 3	SS7ER3	0x0B29
Customer Installation Alarm Status Register	CIASR	0x0B40
Customer Installation Alarm Interrupt Enable Register	CIAIER	0x0B41
BOC Interrupt Status Register	BOCISR	0x0B70
BOC Interrupt Enable Register	BOCIER	0x0B71



TABLE 1: REGISTER SUMMARY

FUNCTION	SYMBOL	HEX
Reserved	-	0x0B72 - 0x0B73
BOC Unstable Interrupt Status Register	BOCUSR	0x0B74
BOC Unstable Interrupt Enable Register	BOCUER	0x0B75
LIU Register Summary - Channel Control Registers		
LIU Channel Control Register 0	LIUCCR0	0x0F00
LIU Channel Control Register 1	LIUCCR1	0x0F01
LIU Channel Control Register 2	LIUCCR2	0x0F02
LIU Channel Control Register 3	LIUCCR3	0x0F03
LIU Channel Control Interrupt Enable Register	LIUCCIER	0x0F04
LIU Channel Control Status Register	LIUCCSR	0x0F05
LIU Channel Control Interrupt Status Register	LIUCCISR	0x0F06
LIU Channel Control Cable Loss Register	LIUCCCCR	0x0F07
LIU Channel Control Arbitrary Register 1	LIUCCAR1	0x0F08
LIU Channel Control Arbitrary Register 2	LIUCCAR2	0x0F09
LIU Channel Control Arbitrary Register 3	LIUCCAR3	0x0F0A
LIU Channel Control Arbitrary Register 4	LIUCCAR4	0x0F0B
LIU Channel Control Arbitrary Register 5	LIUCCAR5	0x0F0C
LIU Channel Control Arbitrary Register 6	LIUCCAR6	0x0F0D
LIU Channel Control Arbitrary Register 7	LIUCCAR7	0x0F0E
LIU Channel Control Arbitrary Register 8	LIUCCAR8	0x0F0F
Reserved	-	0x0F80 - 0x0FDF
LIU Register Summary - Global Control Registers		
LIU Global Control Register 0	LIUGCR0	0x0FE0
LIU Global Control Register 1	LIUGCR1	0x0FE1
LIU Global Control Register 2	LIUGCR2	0x0FE2
LIU Global Control Register 3	LIUGCR3	0x0FE4
LIU Global Control Register 4	LIUGCR4	0x0FE9
LIU Global Control Register 5	LIUGCR5	0x0FEA
Reserved	-	0x0FEB - 0x0FFF

1.0 REGISTER DESCRIPTIONS - T1 MODE

All address on this register description is shown in HEX format

TABLE 2: CLOCK SELECT REGISTER(CSR)

HEX ADDRESS: 0x0100

BIT	FUNCTION	TYPE	DEFAULT	DESCRIPTION-OPERATION
7	LCV Insert	R/W	0	<p>Line Code Violation Insertion</p> <p>This bit is used to force a Line Code Violation (LCV) on the transmit output of TTIP/TRING.</p> <p>A “0” to “1” transition on this bit will cause a single LCV to be inserted on the transmit output of TTIP/TRING.</p>
6	Set T1 Mode	R/W	0	<p>T1 Mode select</p> <p>This bit is used to program the individual channel to operate in either T1 or E1 mode.</p> <p>0 = Configures the selected channel to operate in E1 mode. 1 = Configures the selected channel to operate in T1 mode.</p>
5	Sync All Transmitters to 8kHz	R/W	0	<p>Sync All Transmit Framers to 8kHz</p> <p>This bit permits the user to configure the Transmit T1 Framer block to synchronize its “transmit output” frame alignment with the 8kHz signal that is derived from the MCLK PLL, as described below.</p> <p>0 - Disables the “Sync all Transmit Framers to 8kHz” feature. 1 - Enables the “Sync all Transmit Framers to 8kHz” feature.</p> <p>NOTE: <i>This bit is only active if the MCLK PLL is used as the “Timing Source” for the Transmit T1 Framer blocks. CSS[1:0] of this register allows users to select the transmit source of the framer.</i></p>
4	Clock Loss Detect	R/W	1	<p>Clock Loss Detect Enable/Disable Select</p> <p>This bit enables a clock loss protection feature for the Framer whenever the recovered line clock is used as the timing source for the transmit section. If the LIU loses clock recovery, the Clock Distribution Block will detect this occurrence and automatically begin to use the internal clock derived from MCLK PLL as the Transmit source, until the LIU is able to regain clock recovery.</p> <p>0 = Disables the clock loss protection feature. 1 = Enables the clock loss protection feature.</p> <p>NOTE: <i>This bit needs to be enabled in order to detect the clock loss detection interrupt status (address: 0x0B00, bit 5)</i></p>
3:2	Reserved	R/W	00	Reserved

TABLE 2: CLOCK SELECT REGISTER(CSR)

HEX ADDRESS: 0x0100

BIT	FUNCTION	TYPE	DEFAULT	DESCRIPTION-OPERATION												
1:0	CSS[1:0]	R/W	01	<p>Clock Source Select These bits select the timing source for the Transmit T1 Framer block. These bits can also determine the direction of TxSERCLK, TxSYNC, and TxMSYNC in base rate operation mode (1.544MHz Clock mode). In Base Rate (1.544MHz Clock Mode):</p> <table border="1"> <thead> <tr> <th>CSS[1:0]</th> <th>TRANSMIT SOURCE FOR THE TRANSMIT T1 FRAMER BLOCK</th> <th>DIRECTION OF TxSERCLK</th> </tr> </thead> <tbody> <tr> <td>00/11</td> <td>Loop Timing Mode The recovered line clock is chosen as the timing source.</td> <td>Output</td> </tr> <tr> <td>01</td> <td>External Timing Mode The Transmit Serial Input Clock from the TxSERCLK_n input pin is chosen as the timing source.</td> <td>Input</td> </tr> <tr> <td>10</td> <td>Internal Timing Mode The MCLK PLL is chosen as the timing source.</td> <td>Output</td> </tr> </tbody> </table> <p>NOTE: TxSYNC/TxMSYNC can be programmed as input or output depending on the setting of SYNC INV bit in Register Address 0x0109, bit 4. Please see Register Description for the Synchronization Mux Register (SMR - 0x0109) Table 9.</p> <p>NOTES: In High-Speed or multiplexed modes, TxSERCLK, TxSYNC, and TxMSYNC are all configured as INPUTS only.</p>	CSS[1:0]	TRANSMIT SOURCE FOR THE TRANSMIT T1 FRAMER BLOCK	DIRECTION OF TxSERCLK	00/11	Loop Timing Mode The recovered line clock is chosen as the timing source.	Output	01	External Timing Mode The Transmit Serial Input Clock from the TxSERCLK_n input pin is chosen as the timing source.	Input	10	Internal Timing Mode The MCLK PLL is chosen as the timing source.	Output
CSS[1:0]	TRANSMIT SOURCE FOR THE TRANSMIT T1 FRAMER BLOCK	DIRECTION OF TxSERCLK														
00/11	Loop Timing Mode The recovered line clock is chosen as the timing source.	Output														
01	External Timing Mode The Transmit Serial Input Clock from the TxSERCLK_n input pin is chosen as the timing source.	Input														
10	Internal Timing Mode The MCLK PLL is chosen as the timing source.	Output														

TABLE 3: LINE INTERFACE CONTROL REGISTER (LICR)

HEX ADDRESS: 0x0101

BIT	FUNCTION	TYPE	DEFAULT	DESCRIPTION-OPERATION										
7	FORCE_LOS	R/W	0	<p>Force Transmit LOS (To the Line Side) This bit permits the user to configure the transmit direction circuitry (within the channel) to transmit the LOS pattern to the remote terminal equipment, as described below. 0 - Configures the transmit direction circuitry to transmit "normal" traffic. 1 - Configures the transmit direction circuitry to transmit the LOS Pattern.</p>										
6	Reserved	R/W	0	<p>Single Rail Mode This bit can only be set if the LIU Block is also set to single rail mode. See Register 0x0FE0, bit 7. 0 - Dual Rail 1 - Single Rail</p>										
5:4	LB[1:0]	R/W	00	<p>Framer Loopback Selection These bits are used to select any of the following loop-back modes for the framer section. For LIU loopback modes, see the LIU configuration registers.</p> <table border="1" data-bbox="695 905 1414 1583"> <thead> <tr> <th>LB[1:0]</th> <th>TYPES OF LOOPBACK SELECTED</th> </tr> </thead> <tbody> <tr> <td>00</td> <td>Normal Mode (No LoopBack)</td> </tr> <tr> <td>01</td> <td> <p>Framer Local LoopBack: When framer local loopback is enabled, the transmit PCM input data is looped back to the receive PCM output data. The receive input data at RTIP/RRING is ignored while an All Ones Signal is transmitted out to the line interface.</p> </td> </tr> <tr> <td>10</td> <td> <p>Framer Far-End (Remote) Line LoopBack: When framer remote loopback is enabled, the digital data enters the framer interface, however does not enter the framing blocks. The receive digital data from the LIU is allowed to pass through the LIU Decoder/ Encoder circuitry before returning to the line interface.</p> </td> </tr> <tr> <td>11</td> <td> <p>Framer Payload LoopBack: When framer payload loopback is enabled, the raw data within the receive time slots are looped back to the transmit framer block where the data is re-framed according to the transmit timing.</p> </td> </tr> </tbody> </table>	LB[1:0]	TYPES OF LOOPBACK SELECTED	00	Normal Mode (No LoopBack)	01	<p>Framer Local LoopBack: When framer local loopback is enabled, the transmit PCM input data is looped back to the receive PCM output data. The receive input data at RTIP/RRING is ignored while an All Ones Signal is transmitted out to the line interface.</p>	10	<p>Framer Far-End (Remote) Line LoopBack: When framer remote loopback is enabled, the digital data enters the framer interface, however does not enter the framing blocks. The receive digital data from the LIU is allowed to pass through the LIU Decoder/ Encoder circuitry before returning to the line interface.</p>	11	<p>Framer Payload LoopBack: When framer payload loopback is enabled, the raw data within the receive time slots are looped back to the transmit framer block where the data is re-framed according to the transmit timing.</p>
LB[1:0]	TYPES OF LOOPBACK SELECTED													
00	Normal Mode (No LoopBack)													
01	<p>Framer Local LoopBack: When framer local loopback is enabled, the transmit PCM input data is looped back to the receive PCM output data. The receive input data at RTIP/RRING is ignored while an All Ones Signal is transmitted out to the line interface.</p>													
10	<p>Framer Far-End (Remote) Line LoopBack: When framer remote loopback is enabled, the digital data enters the framer interface, however does not enter the framing blocks. The receive digital data from the LIU is allowed to pass through the LIU Decoder/ Encoder circuitry before returning to the line interface.</p>													
11	<p>Framer Payload LoopBack: When framer payload loopback is enabled, the raw data within the receive time slots are looped back to the transmit framer block where the data is re-framed according to the transmit timing.</p>													
3:2	Reserved	R/W	0	Reserved										

TABLE 3: LINE INTERFACE CONTROL REGISTER (LICR)

HEX ADDRESS: 0X0101

BIT	FUNCTION	TYPE	DEFAULT	DESCRIPTION-OPERATION
1	Encode B8ZS	R/W	0	<p>Encode AMI or B8ZS/HDB3 Line Code Select</p> <p>This bit enables or disables the B8ZS/HDB3 encoder on the transmit path.</p> <p>0 = Enables the B8ZS encoder. 1 = Disables the B8ZS encoder.</p> <p>NOTE: When B8ZS encoder is disabled, AMI line code is used.</p>
0	Decode AMI/B8ZS	R/W	0	<p>Decode AMI or B8ZS/HDB3 Line Code Select</p> <p>This bit enables or disables the B8ZS/HDB3 decoder on the receive path.</p> <p>0 = Enables the B8ZS decoder. 1 = Disables the B8ZS decoder.</p> <p>NOTE: When B8ZS decoder is disabled, AMI line code is received.</p>

TABLE 4: GENERAL PURPOSE INPUT/OUTPUT CONTROL REGISTER (GPIOCR)

HEX ADDRESS: 0x0102

BIT	FUNCTION	TYPE	DEFAULT	DESCRIPTION-OPERATION
7-4	GPIO0_3DIR GPIO0_2DIR GPIO0_1DIR GPIO0_0DIR	R/W	1111	<p>GPIO0_3/GPIO0_2/GPIO0_1/GPIO0_0 Direction</p> <p>These bits permit the user to define the General Purpose I/O Pins, GPIO0_3/GPIO0_2/GPIO0_1/GPIO0_0 as either Input pins or Output pins, as described below.</p> <p>0 – Configures GPIO0_3/GPIO0_2/GPIO0_1/GPIO0_0 to function as input pins.</p> <p>1 – Configures GPIO0_3/GPIO0_2/GPIO0_1/GPIO0_0 to function as output pins.</p> <ol style="list-style-type: none"> 1. If GPIO0_3/GPIO0_2/GPIO0_1/GPIO0_0 are configured to function as input pins, then the user can monitor the state of these input pins by reading out the state of Bit 3-0 (GPIO0_3/GPIO0_2/GPIO0_1/GPIO0_0) within this register. 2. If GPIO0_3/GPIO0_2/GPIO0_1/GPIO0_0 are configured to function as output pins, then the user can control the state of these output pins by writing the appropriate value into Bit 3-0 (GPIO0_3/GPIO0_2/GPIO0_1/GPIO0_0) within this register.
3-0	GPIO0_3 GPIO0_2 GPIO0_1 GPIO0_0	R/W	0000	<p>GPIO0_3/GPIO0_2/GPIO0_1/GPIO0_0 Control</p> <p>The exact function of this bit depends upon whether General Purpose I/O Pins, GPIO0_3/GPIO0_2/GPIO0_1/GPIO0_0 have been configured to function as input or output pins, as described below.</p> <p>If GPIO0_3/GPIO0_2/GPIO0_1/GPIO0_0 are configured to function as input pins:</p> <p>If GPIO0_3/GPIO0_2/GPIO0_1/GPIO0_0 are configured to function as input pins, then the user can monitor the state of the corresponding input pin by reading out the state of these bits.</p> <p><i>NOTE: If GPIO0_3/GPIO0_2/GPIO0_1/GPIO0_0 are configured to function as input pins, then writing to this particular register will have no effect on the state of this pin.</i></p> <p>If GPIO0_3/GPIO0_2/GPIO0_1/GPIO0_0 are configured to function as output pins:</p> <p>If GPIO0_3/GPIO0_2/GPIO0_1/GPIO0_0 are configured to function as output pins, then the user can control the state of the corresponding output pin by writing the appropriate value to these bits.</p> <p><i>NOTE: GPIO0_3/GPIO0_2/GPIO0_1/GPIO0_0 can be configured to function as input or output pins, by writing the appropriate value to Bit 7-4 (GPIO0_3DIR/GPIO0_2DIR/GPIO0_1DIR/GPIO0_0DIR) within this register.</i></p>

TABLE 5: FRAMING SELECT REGISTER (FSR)

HEX ADDRESS: 0X0107

BIT	FUNCTION	TYPE	DEFAULT	DESCRIPTION-OPERATION
7	Signaling update on Superframe Boundaries	R/W	0	<p>Enable Robbed-Bit Signaling Update on Superframe Boundary on Both Transmit and Receive Direction</p> <p>This bit enables or disables robbed-bit signaling update on the superframe boundary for both the transmit and receive side of the framer.</p> <p>On the Receive Side:</p> <p>If signaling update is enabled, signaling data on the receive side (RxSIG pin and Signaling Array Register - RSAR) will be updated on the superframe boundary, otherwise, signaling data will be updated as soon as it is received.</p> <p>On the Transmit Side:</p> <p>If signaling update is enabled, any signaling data changes on the transmit side will be transmitted on the superframe boundary, otherwise, signaling data will be transmitted as soon as it is changed.</p> <p>0 - Disables the signaling update feature for both transmit and receive. 1 - Enables the signaling update feature for both transmit and receive.</p>
6	Force CRC Errors	R/W	0	<p>Force CRC Errors (To the Line Side)</p> <p>This bit permits the user to force the Transmit T1 Framer block to transmit CRC errors within the outbound T1 data-stream, as depicted below.</p> <p>0 - Disables CRC error transmission on the outbound T1 stream. 1 - Enables CRC error transmission on the outbound T1 stream.</p>
5	J1_MODE	R/W	0	<p>J1 Mode</p> <p>This bit is used to configure the device in J1 mode. Once the device is configured in J1 mode, the following two changes will happen:</p> <ol style="list-style-type: none"> 1. CRC calculation is done in J1 format. The J1 CRC6 calculation is based on the actual values of all 4632 bits in a T1 multi-frame including Fe bits instead of assuming all Fe bits to be a one in T1 format. 2. Receive and Transmit Yellow Alarm signal format is interpreted per the J1 standard. (J1-SF or J1-ESF) <p>0 - Configures the device in T1 mode. (Default) 1 - Configures the device in J1 mode.</p> <p>NOTE: Users can select between J1-SF or J1-ESF by setting this bit and the T1 Framing Mode Select Bits[2:0] (Bits 2-0 within this register).</p>
4	ONEONLY	R/W	0	<p>Allow Only One Sync Candidate</p> <p>This bit is used to specify one of the synchronization criteria that the Receive T1 Framer block employs.</p> <p>0 - Allows the Receive T1 Framer to select any one of the winners in the matching process when there are two or more valid synchronization patterns appear in the required time frame. 1 - Allows the Receive T1 Framer to declare success of match when there is only one candidate left in the required time frame.</p>

TABLE 5: FRAMING SELECT REGISTER (FSR)

HEX ADDRESS: 0x0107

BIT	FUNCTION	TYPE	DEFAULT	DESCRIPTION-OPERATION																								
3	FASTSYNC	R/W	0	<p>Faster Sync Algorithm</p> <p>This bit is used to specify one of the synchronization criteria that the Receive T1 Framer block employs. If this “Faster Sync Algorithm” is enabled, the Receive T1 Framer Block will declare synchronization earlier. The table below specifies the number of consecutive frames with correct F-bits that the T1 Receive framer must receive in order to declare “SYNC” when FASTSYNC is enabled or disabled.</p> <table border="1" data-bbox="776 552 1349 884"> <thead> <tr> <th>Framing</th> <th>FastSync = 0</th> <th>FastSync = 1</th> </tr> </thead> <tbody> <tr> <td>ESF</td> <td>96</td> <td>48</td> </tr> <tr> <td>SF</td> <td>48</td> <td>24</td> </tr> <tr> <td>N</td> <td>48</td> <td>24</td> </tr> <tr> <td>SLC ® 96</td> <td>48</td> <td>24</td> </tr> </tbody> </table> <p>0 - Disables FASTSYNC feature. 1 - Enables FASTSYNC feature.</p>	Framing	FastSync = 0	FastSync = 1	ESF	96	48	SF	48	24	N	48	24	SLC ® 96	48	24									
Framing	FastSync = 0	FastSync = 1																										
ESF	96	48																										
SF	48	24																										
N	48	24																										
SLC ® 96	48	24																										
2-0	FSI[2:0]	R/W	000	<p>T1 Framing Mode Select [2:0]</p> <p>These three bits permit the user to select the exact T1 framing format that the channel is to operate in. Bit 2 is MSB and Bit 0 is LSB. The following table shows the five different framing formats that can be selected by configuring these three bits accordingly.</p> <p>NOTE: Changing Framing formats 'on the fly' will cause the Receive T1 Framer block to undergo a “Reframe” event.</p> <table border="1" data-bbox="847 1304 1279 1591"> <thead> <tr> <th>Framing</th> <th>FS[2]</th> <th>FS[1]</th> <th>FS[0]</th> </tr> </thead> <tbody> <tr> <td>ESF</td> <td>0</td> <td>X</td> <td>X</td> </tr> <tr> <td>SF</td> <td>1</td> <td>0</td> <td>1</td> </tr> <tr> <td>N</td> <td>1</td> <td>1</td> <td>0</td> </tr> <tr> <td>T1DM</td> <td>1</td> <td>1</td> <td>1</td> </tr> <tr> <td>SLC®96</td> <td>1</td> <td>0</td> <td>0</td> </tr> </tbody> </table>	Framing	FS[2]	FS[1]	FS[0]	ESF	0	X	X	SF	1	0	1	N	1	1	0	T1DM	1	1	1	SLC®96	1	0	0
Framing	FS[2]	FS[1]	FS[0]																									
ESF	0	X	X																									
SF	1	0	1																									
N	1	1	0																									
T1DM	1	1	1																									
SLC®96	1	0	0																									

TABLE 6: ALARM GENERATION REGISTER (AGR)

HEX ADDRESS: 0x0108

BIT	FUNCTION	TYPE	DEFAULT	DESCRIPTION-OPERATION
7	Yellow Alarm - One Second Rule	R/W	0	<p>One-Second Yellow Alarm Rule Enforcement</p> <p>This bit is used to enforce the one-second yellow alarm rule according to the yellow alarm (RAI) transmission duration per the ANSI standards.</p> <p>If the one second alarm rule is enforced, the following will happen:</p> <ol style="list-style-type: none"> 1. RAI will be transmitted for at least one second for both ESF and SF. 2. There must be a minimum of one second delay between termination of the first RAI and the initiation of a subsequent RAI. 3. ALARM_ENB bit (see description of bit 6 of this register) controls the duration of RAI. 4. YEL[0] & YEL[1] (see description of bits 5-4 of this register) controls the format of RAI. <p>If the one second alarm rule is NOT enforced, the following will happen:</p> <ol style="list-style-type: none"> 1. RAI will be transmitted for at least one second for ESF and SF. 2. Minimum one second delay between termination of the first RAI and the initiation of the subsequent RAI is NOT enforced. 3. YEL[0] and YEL[1] bits (see description of bits 5-4 of this register) are used to control the duration AND the format of RAI transmission. <p>0 - The one-second yellow alarm rule is NOT enforced. 1 - The one-second yellow alarm rule is enforced.</p> <p>NOTE: When setting this bit to '0', yellow alarm transmission will be backward compatible with the XRT86L38 device. XRT86L38 does not support the one-second yellow alarm rule.</p>
6	ALARM_ENB	R/W	0	<p>Yellow Alarm Transmission Enable</p> <p>This bit is used to control the duration of yellow alarm (RAI) when the one-second yellow alarm rule is enforced (bit 7 of this register set to '1').</p> <p>When the one-second yellow alarm rule is not enforced (bit 7 of this register set to '0'), the duration of the RAI is controlled by the YEL[0] and YEL[1] bits (bits 5-4 of this register).</p> <p>If the one-second alarm rule is enforced:</p> <p>0 - Stop the transmission of yellow alarm (see description of bits 5-4). 1 - Start the transmission of yellow alarm (see description of bits 5-4).</p> <p>NOTE: This bit has no function if the one second alarm rule is not enforced.</p>

TABLE 6: ALARM GENERATION REGISTER (AGR)

HEX ADDRESS: 0x0108

BIT	FUNCTION	TYPE	DEFAULT	DESCRIPTION-OPERATION										
5-4	YEL[1:0]	R/W	00	<p>Yellow Alarm (RAI) Duration and Format</p> <p>The exact function of these bits depends on whether or not the one-second yellow alarm rule is enforced. (Bit 7 of this register). The decoding of these bits are explained in Table 7 and Table 8 below.</p> <p style="text-align: center;">TABLE 7: YELLOW ALARM DURATION AND FORMAT WHEN ONE SECOND RULE IS NOT ENFORCED</p> <table border="1" style="width: 100%;"> <thead> <tr> <th>YEL[1:0]</th> <th>YELLOW ALARM DURATION AND FORMAT</th> </tr> </thead> <tbody> <tr> <td>00</td> <td>Disable the transmission of yellow alarm</td> </tr> <tr> <td>01</td> <td> <p>SF or N mode: RAI is transmitted as bit 2 = 0 (second MSB) in all DS0 data channel.</p> <p>T1DM mode: RAI is transmitted as Y-bit = 0 (6th bit in the SYNC byte).</p> <p>ESF mode:</p> <ol style="list-style-type: none"> If YEL[0] bit is set 'high' for a duration shorter or equal to the time required to transmit 255 patterns of 1111_1111_0000_0000 on the 4-kbit/s data link bits (M1-M12), RAI is transmitted for 255 patterns of 1111_1111_0000_0000 (approximately 1 second) If YEL[0] bit is set 'high' for a duration longer than the time required to transmit 255 patterns of 1111_1111_0000_0000 on the 4-kbit/s data link bits (M1-M12), RAI transmission continues until YEL[0] bit is set 'low'. If YEL[0] bit forms another pulse during the RAI transmission, it resets the pattern counter and extends the RAI duration for another 255 patterns of 1111_1111_0000_0000. (approximately 1 second) </td> </tr> <tr> <td>10</td> <td> <p>SF mode: RAI is transmitted as a "1" in the Fs bit of frame 12 (This is RAI for J1 SF standard).</p> <p>T1DM mode: RAI is transmitted as Y-bit = 0 (6th bit in the SYNC byte).</p> <p>ESF mode: RAI is controlled by the duration of YEL[1] bit. This allows continuous RAI of any length.</p> </td> </tr> <tr> <td>11</td> <td> <p>SF, N, and T1DM mode: RAI format is the same as described above when YEL[1:0] is set to '01'.</p> <p>ESF mode: RAI duration is the same as described above when YEL[1:0] is set to '01', except that format of RAI is transmitted as 255 patterns of 1111_1111_1111_1111 (sixteen ones) on the 4kbits/s data link bits instead of 255 patterns of 1111_1111_0000_0000.</p> <p>NOTE: 255 patterns of 1111_1111_1111_111 is the J1 ESF RAI standard)</p> </td> </tr> </tbody> </table>	YEL[1:0]	YELLOW ALARM DURATION AND FORMAT	00	Disable the transmission of yellow alarm	01	<p>SF or N mode: RAI is transmitted as bit 2 = 0 (second MSB) in all DS0 data channel.</p> <p>T1DM mode: RAI is transmitted as Y-bit = 0 (6th bit in the SYNC byte).</p> <p>ESF mode:</p> <ol style="list-style-type: none"> If YEL[0] bit is set 'high' for a duration shorter or equal to the time required to transmit 255 patterns of 1111_1111_0000_0000 on the 4-kbit/s data link bits (M1-M12), RAI is transmitted for 255 patterns of 1111_1111_0000_0000 (approximately 1 second) If YEL[0] bit is set 'high' for a duration longer than the time required to transmit 255 patterns of 1111_1111_0000_0000 on the 4-kbit/s data link bits (M1-M12), RAI transmission continues until YEL[0] bit is set 'low'. If YEL[0] bit forms another pulse during the RAI transmission, it resets the pattern counter and extends the RAI duration for another 255 patterns of 1111_1111_0000_0000. (approximately 1 second) 	10	<p>SF mode: RAI is transmitted as a "1" in the Fs bit of frame 12 (This is RAI for J1 SF standard).</p> <p>T1DM mode: RAI is transmitted as Y-bit = 0 (6th bit in the SYNC byte).</p> <p>ESF mode: RAI is controlled by the duration of YEL[1] bit. This allows continuous RAI of any length.</p>	11	<p>SF, N, and T1DM mode: RAI format is the same as described above when YEL[1:0] is set to '01'.</p> <p>ESF mode: RAI duration is the same as described above when YEL[1:0] is set to '01', except that format of RAI is transmitted as 255 patterns of 1111_1111_1111_1111 (sixteen ones) on the 4kbits/s data link bits instead of 255 patterns of 1111_1111_0000_0000.</p> <p>NOTE: 255 patterns of 1111_1111_1111_111 is the J1 ESF RAI standard)</p>
YEL[1:0]	YELLOW ALARM DURATION AND FORMAT													
00	Disable the transmission of yellow alarm													
01	<p>SF or N mode: RAI is transmitted as bit 2 = 0 (second MSB) in all DS0 data channel.</p> <p>T1DM mode: RAI is transmitted as Y-bit = 0 (6th bit in the SYNC byte).</p> <p>ESF mode:</p> <ol style="list-style-type: none"> If YEL[0] bit is set 'high' for a duration shorter or equal to the time required to transmit 255 patterns of 1111_1111_0000_0000 on the 4-kbit/s data link bits (M1-M12), RAI is transmitted for 255 patterns of 1111_1111_0000_0000 (approximately 1 second) If YEL[0] bit is set 'high' for a duration longer than the time required to transmit 255 patterns of 1111_1111_0000_0000 on the 4-kbit/s data link bits (M1-M12), RAI transmission continues until YEL[0] bit is set 'low'. If YEL[0] bit forms another pulse during the RAI transmission, it resets the pattern counter and extends the RAI duration for another 255 patterns of 1111_1111_0000_0000. (approximately 1 second) 													
10	<p>SF mode: RAI is transmitted as a "1" in the Fs bit of frame 12 (This is RAI for J1 SF standard).</p> <p>T1DM mode: RAI is transmitted as Y-bit = 0 (6th bit in the SYNC byte).</p> <p>ESF mode: RAI is controlled by the duration of YEL[1] bit. This allows continuous RAI of any length.</p>													
11	<p>SF, N, and T1DM mode: RAI format is the same as described above when YEL[1:0] is set to '01'.</p> <p>ESF mode: RAI duration is the same as described above when YEL[1:0] is set to '01', except that format of RAI is transmitted as 255 patterns of 1111_1111_1111_1111 (sixteen ones) on the 4kbits/s data link bits instead of 255 patterns of 1111_1111_0000_0000.</p> <p>NOTE: 255 patterns of 1111_1111_1111_111 is the J1 ESF RAI standard)</p>													

TABLE 6: ALARM GENERATION REGISTER (AGR)

HEX ADDRESS: 0x0108

BIT	FUNCTION	TYPE	DEFAULT	DESCRIPTION-OPERATION										
5-4	YEL[1:0]	R/W	00	<p>(Continued)</p> <p>TABLE 8: YELLOW ALARM FORMAT WHEN ONE SECOND RULE IS ENFORCED</p> <table border="1"> <thead> <tr> <th>YEL[1:0]</th> <th>YELLOW ALARM FORMAT</th> </tr> </thead> <tbody> <tr> <td>00</td> <td>Disable the transmission of yellow alarm</td> </tr> <tr> <td>01</td> <td> <p>SF or N mode: RAI is transmitted as bit 2 = 0 (second MSB) in all DS0 data channel.</p> <p>T1DM mode: RAI is transmitted as Y-bit = 0 (6th bit in the SYNC byte).</p> <p>ESF mode: YEL[1:0] controls the format of RAI. When YEL[1:0] is set to '01', RAI is transmitted as 255 patterns of 1111_1111_0000_0000 on the 4-kbit/s data link (M1-M12) (approximately 1 second). ALARM_ENB (Bit 6 of this register) controls the duration of RAI as described below:</p> <ol style="list-style-type: none"> 1. If ALARM_ENB bit is set 'high' for a duration shorter or equal to the time required to transmit 255 pattern of 1111_1111_0000_0000 on the 4-kbit/s data link (M1-M12), RAI is transmitted for 255 patterns. (approximately 1 second) 2. If ALARM_ENB bit is set 'high' for a duration longer than the time required to transmit 255 patterns of 1111_1111_0000_0000 on the 4-kbit/s data link (M1-M12), RAI continues until ALARM_ENB bit is set 'low'. 3. If ALARM_ENB forms another pulse during an alarm transmission, it resets the pattern counter and extends the RAI duration for another 255 patterns.(approximately 1 second) <p><i>NOTE: A minimum of one second delay between termination of the first RAI and the initiation of a subsequent RAI is enforced.</i></p> </td> </tr> <tr> <td>10</td> <td> <p>SF mode: RAI is transmitted as a "1" in the Fs bit of frame 12 (This is RAI for J1 SF standard).</p> <p>T1DM mode: RAI is transmitted as Y-bit = 0 (6th bit in the SYNC byte).</p> <p>ESF mode: RAI is controlled by the duration of ALARM_ENB bit. This allows continuous RAI of any length.</p> </td> </tr> <tr> <td>11</td> <td> <p>SF, N, and T1DM mode: RAI format is the same as described above when YEL[1:0] is set to '01'.</p> <p>ESF mode: RAI duration is the same as described above when YEL[1:0] is set to '01', except that format of RAI is transmitted as 255 patterns of 1111_1111_1111_1111 on the 4kbits/s data link bits (J1 ESF standard) instead of 255 patterns of 1111_1111_0000_0000.</p> </td> </tr> </tbody> </table>	YEL[1:0]	YELLOW ALARM FORMAT	00	Disable the transmission of yellow alarm	01	<p>SF or N mode: RAI is transmitted as bit 2 = 0 (second MSB) in all DS0 data channel.</p> <p>T1DM mode: RAI is transmitted as Y-bit = 0 (6th bit in the SYNC byte).</p> <p>ESF mode: YEL[1:0] controls the format of RAI. When YEL[1:0] is set to '01', RAI is transmitted as 255 patterns of 1111_1111_0000_0000 on the 4-kbit/s data link (M1-M12) (approximately 1 second). ALARM_ENB (Bit 6 of this register) controls the duration of RAI as described below:</p> <ol style="list-style-type: none"> 1. If ALARM_ENB bit is set 'high' for a duration shorter or equal to the time required to transmit 255 pattern of 1111_1111_0000_0000 on the 4-kbit/s data link (M1-M12), RAI is transmitted for 255 patterns. (approximately 1 second) 2. If ALARM_ENB bit is set 'high' for a duration longer than the time required to transmit 255 patterns of 1111_1111_0000_0000 on the 4-kbit/s data link (M1-M12), RAI continues until ALARM_ENB bit is set 'low'. 3. If ALARM_ENB forms another pulse during an alarm transmission, it resets the pattern counter and extends the RAI duration for another 255 patterns.(approximately 1 second) <p><i>NOTE: A minimum of one second delay between termination of the first RAI and the initiation of a subsequent RAI is enforced.</i></p>	10	<p>SF mode: RAI is transmitted as a "1" in the Fs bit of frame 12 (This is RAI for J1 SF standard).</p> <p>T1DM mode: RAI is transmitted as Y-bit = 0 (6th bit in the SYNC byte).</p> <p>ESF mode: RAI is controlled by the duration of ALARM_ENB bit. This allows continuous RAI of any length.</p>	11	<p>SF, N, and T1DM mode: RAI format is the same as described above when YEL[1:0] is set to '01'.</p> <p>ESF mode: RAI duration is the same as described above when YEL[1:0] is set to '01', except that format of RAI is transmitted as 255 patterns of 1111_1111_1111_1111 on the 4kbits/s data link bits (J1 ESF standard) instead of 255 patterns of 1111_1111_0000_0000.</p>
YEL[1:0]	YELLOW ALARM FORMAT													
00	Disable the transmission of yellow alarm													
01	<p>SF or N mode: RAI is transmitted as bit 2 = 0 (second MSB) in all DS0 data channel.</p> <p>T1DM mode: RAI is transmitted as Y-bit = 0 (6th bit in the SYNC byte).</p> <p>ESF mode: YEL[1:0] controls the format of RAI. When YEL[1:0] is set to '01', RAI is transmitted as 255 patterns of 1111_1111_0000_0000 on the 4-kbit/s data link (M1-M12) (approximately 1 second). ALARM_ENB (Bit 6 of this register) controls the duration of RAI as described below:</p> <ol style="list-style-type: none"> 1. If ALARM_ENB bit is set 'high' for a duration shorter or equal to the time required to transmit 255 pattern of 1111_1111_0000_0000 on the 4-kbit/s data link (M1-M12), RAI is transmitted for 255 patterns. (approximately 1 second) 2. If ALARM_ENB bit is set 'high' for a duration longer than the time required to transmit 255 patterns of 1111_1111_0000_0000 on the 4-kbit/s data link (M1-M12), RAI continues until ALARM_ENB bit is set 'low'. 3. If ALARM_ENB forms another pulse during an alarm transmission, it resets the pattern counter and extends the RAI duration for another 255 patterns.(approximately 1 second) <p><i>NOTE: A minimum of one second delay between termination of the first RAI and the initiation of a subsequent RAI is enforced.</i></p>													
10	<p>SF mode: RAI is transmitted as a "1" in the Fs bit of frame 12 (This is RAI for J1 SF standard).</p> <p>T1DM mode: RAI is transmitted as Y-bit = 0 (6th bit in the SYNC byte).</p> <p>ESF mode: RAI is controlled by the duration of ALARM_ENB bit. This allows continuous RAI of any length.</p>													
11	<p>SF, N, and T1DM mode: RAI format is the same as described above when YEL[1:0] is set to '01'.</p> <p>ESF mode: RAI duration is the same as described above when YEL[1:0] is set to '01', except that format of RAI is transmitted as 255 patterns of 1111_1111_1111_1111 on the 4kbits/s data link bits (J1 ESF standard) instead of 255 patterns of 1111_1111_0000_0000.</p>													

TABLE 6: ALARM GENERATION REGISTER (AGR)

HEX ADDRESS: 0x0108

BIT	FUNCTION	TYPE	DEFAULT	DESCRIPTION-OPERATION								
3-2	Transmit AIS Pattern Select[1:0]	R/W	00	<p>Transmit AIS Pattern Select[1:0]: These two bits permit the user to do the following.</p> <ol style="list-style-type: none"> To select the appropriate AIS Pattern that the Transmit T1 Framer block will transmit to the remote terminal equipment, and To command (via Software Control) the Transmit T1 Framer block to transmit that particular AIS Pattern to the remote terminal equipment, as depicted below. <table border="1" data-bbox="584 525 1347 924"> <thead> <tr> <th>AISG[1:0]</th> <th>TYPES OF AIS PATTERNS TRANSMITTED</th> </tr> </thead> <tbody> <tr> <td>00/10</td> <td>Disable AIS Alarm Generation The Transmit T1 Framer block will transmit “normal” T1 traffic to the remote terminal equipment.</td> </tr> <tr> <td>01</td> <td>Enable Unframed AIS Alarm Generation Transmit T1 Framer block will transmit an Unframed All Ones Pattern, as an AIS Pattern.</td> </tr> <tr> <td>11</td> <td>Enable Framed AIS Alarm Generation Transmit T1 Framer block will transmit a Framed, All Ones Pattern, as the AIS Pattern.</td> </tr> </tbody> </table> <p><i>NOTE: For normal operation (e.g., to configure the Transmit T1 Framer block to transmit normal T1 traffic) the user should set this bit to “[X, 0]”</i></p>	AISG[1:0]	TYPES OF AIS PATTERNS TRANSMITTED	00/10	Disable AIS Alarm Generation The Transmit T1 Framer block will transmit “normal” T1 traffic to the remote terminal equipment.	01	Enable Unframed AIS Alarm Generation Transmit T1 Framer block will transmit an Unframed All Ones Pattern, as an AIS Pattern.	11	Enable Framed AIS Alarm Generation Transmit T1 Framer block will transmit a Framed, All Ones Pattern, as the AIS Pattern.
AISG[1:0]	TYPES OF AIS PATTERNS TRANSMITTED											
00/10	Disable AIS Alarm Generation The Transmit T1 Framer block will transmit “normal” T1 traffic to the remote terminal equipment.											
01	Enable Unframed AIS Alarm Generation Transmit T1 Framer block will transmit an Unframed All Ones Pattern, as an AIS Pattern.											
11	Enable Framed AIS Alarm Generation Transmit T1 Framer block will transmit a Framed, All Ones Pattern, as the AIS Pattern.											
1-0	AIS Defect Declaration Criteria [1:0]	R/W	00	<p>AIS Defect Declaration Criteria[1:0]: These bits permit the user to specify the types of AIS Patterns that the Receive T1 Framer block must detect before it will declare the AIS defect condition.</p> <table border="1" data-bbox="597 1155 1372 1522"> <thead> <tr> <th>AISD[1:0]</th> <th>AIS Defect Declaration Criteria</th> </tr> </thead> <tbody> <tr> <td>00/10</td> <td>AIS Detection Disabled AIS Defect Condition will NOT be declared.</td> </tr> <tr> <td>01</td> <td>Enable Unframed and Framed AIS Alarm Detection ReceiveT1 Framer block will detect both Unframed and Framed AIS pattern</td> </tr> <tr> <td>11</td> <td>Enable Framed AIS Alarm Detection Receive T1 Framer block will detect only Framed AIS pattern</td> </tr> </tbody> </table>	AISD[1:0]	AIS Defect Declaration Criteria	00/10	AIS Detection Disabled AIS Defect Condition will NOT be declared.	01	Enable Unframed and Framed AIS Alarm Detection ReceiveT1 Framer block will detect both Unframed and Framed AIS pattern	11	Enable Framed AIS Alarm Detection Receive T1 Framer block will detect only Framed AIS pattern
AISD[1:0]	AIS Defect Declaration Criteria											
00/10	AIS Detection Disabled AIS Defect Condition will NOT be declared.											
01	Enable Unframed and Framed AIS Alarm Detection ReceiveT1 Framer block will detect both Unframed and Framed AIS pattern											
11	Enable Framed AIS Alarm Detection Receive T1 Framer block will detect only Framed AIS pattern											

TABLE 9: SYNCHRONIZATION MUX REGISTER (SMR)

HEX ADDRESS: 0X0109

BIT	FUNCTION	TYPE	DEFAULT	DESCRIPTION-OPERATION
7	Reserved	-	-	Reserved
6	MFRAMEALIGN	R/W	0	<p>Transmit Multiframe Sync Alignment</p> <p>This bit forces Transmit T1 framer block to align with the backplane multiframe boundary (TxMSYNC_n).</p> <p>0 = Do not force the transmit T1 framer block to align with the TxM-SYNC signal.</p> <p>1 = Force the transmit T1 framer block to align with the TxMSYNC signal.</p> <p>NOTE: This bit is not used in base rate (1.544MHz Clock) mode.</p>
5	MSYNC	R/W	0	<p>Transmit Super Frame Boundary</p> <p>This bit provides an option to use the transmit single frame boundary (TxSYNC) as the transmit multi-frame boundary (TxMSYNC) in high speed or multiplexed modes. In 1.544MHz clock mode (base rate), the TxMSYNC is used as the transmit superframe boundary, in other clock modes (i.e. high speed or multiplexed modes), TxMSYNC is used as an input transmit clock for the backplane interface.</p> <p>0 = Configures the TxSYNC as a single frame boundary.</p> <p>1 = Configures the TxSYNC as a superframe boundary (TxMSYNC) in high-speed or multiplexed mode.</p> <p>NOTE: This bit is not used in base rate (1.544MHz Clock) mode.</p>