



Chipsmall Limited consists of a professional team with an average of over 10 year of expertise in the distribution of electronic components. Based in Hongkong, we have already established firm and mutual-benefit business relationships with customers from,Europe,America and south Asia,supplying obsolete and hard-to-find components to meet their specific needs.

With the principle of “Quality Parts,Customers Priority,Honest Operation,and Considerate Service”,our business mainly focus on the distribution of electronic components. Line cards we deal with include Microchip,ALPS,ROHM,Xilinx,Pulse,ON,Everlight and Freescale. Main products comprise IC,Modules,Potentiometer,IC Socket,Relay,Connector.Our parts cover such applications as commercial,industrial, and automotives areas.

We are looking forward to setting up business relationship with you and hope to provide you with the best service and solution. Let us make a better world for our industry!



Contact us

Tel: +86-755-8981 8866 Fax: +86-755-8427 6832

Email & Skype: info@chipsmall.com Web: www.chipsmall.com

Address: A1208, Overseas Decoration Building, #122 Zhenhua RD., Futian, Shenzhen, China



EN	YR20.246 Installation Manual	Redundancy Module 24V, 20A
DE	YR20.246 Installationsanleitung	Redundanzmodul 24V, 20A
FR	YR20.246 Manuel d'installation	Module redondant 24V, 20A
ES	YR20.246 Manual de instalación	Módulo de redundancia 24V, 20A
IT	YR20.246 Manuale di Installazione	Modulo di ridondanza 24V, 20A
PT	YR20.246 Manual de instalação	Módulo de redundância 24V, 20A

PULS

Doc. ID: PU-431.015.00-xx-xxZ (2018-03-12-MR1)

Read this first!

English

Before operating this device, please read this manual thoroughly and retain this manual for future reference! This device may only be installed and put into operation by qualified personnel. If damage or malfunction should occur during operation, immediately turn power off and send device to the factory for inspection. The device does not contain serviceable parts. The information presented in this document is believed to be accurate and reliable and may change without notice. For any clarifications the English translation will be used.

⚠ WARNING Risk of electrical shock, fire, personal injury, or death:

- Turn power off before working on the device. Protect against inadvertent re-powering.
- Do not open, modify or repair the device.
- Use caution to prevent any foreign objects from entering the housing.
- Do not use in wet locations or in areas where moisture or condensation can be expected.
- Do not touch during power-on and immediately after power-off. Hot surfaces may cause burns.

A lire avant mise sous tension!

Français

Veuillez lire ces instructions de montage et d'entretien avant de mettre l'alimentation sous tension. Conservez ce manuel qui vous sera toujours utile. Cette alimentation ne doit être installée que par du personnel qualifié et compétent. En cas de dommage ou dysfonctionnement, coupez immédiatement la tension d'alimentation et retournez l'appareil à l'usine pour vérification. L'alimentation ne contient pas de pièces échangeables. Les données indiquées dans ce document servent uniquement à donner une description du produit et n'ont aucune valeur juridique. En cas de divergences, le texte anglais fait foi.

⚠ AVERTISSEMENT Prendre en compte les points suivants, afin d'éviter toute détérioration électrique, incendie, dommage aux personnes ou mort:

- Mettre l'alimentation hors tension avant toute intervention sur celle-ci et s'assurer qu'il n'y a pas risque de redémarrage.
- Ne pas ouvrir, modifier ou réparer l'alimentation.
- Veiller à ce qu'aucun objet ne rentre en contact avec l'intérieur de l'alimentation (trombones, pièces métalliques).
- Ne pas faire fonctionner l'appareil dans un environnement humide ou dans un environnement où il peut y avoir de la condensation.
- Ne pas toucher le carter pendant le fonctionnement ou directement après la mise hors tension. Surface chaude risquant d'entraîner des blessures.

Leggere prima questa parte!

Italiano

Prima di collegare il sistema di alimentazione elettrica si prega di leggere attentamente le seguenti avvertenze. Conservare le istruzioni per la consultazione futura. Il sistema di alimentazione elettrica deve essere installato solo da personale competente e qualificato. Se durante il funzionamento si verificano anomalie o guasti, scollegare immediatamente la tensione di alimentazione. In entrambi i casi è necessario far controllare l'apparecchio dal produttore! I dati sono indicati solo a scopo descrittivo del prodotto e non vanno considerati come caratteristiche garantite dell'apparecchio. In caso di differenze o problemi è valido il testo inglese.

⚠ AVVERTENZA Il mancato rispetto delle seguenti norme può provocare folgorazione elettrica, incendi, gravi incidenti e perfino la morte:

- Prima di eseguire interventi di installazione, di manutenzione o di modifica scollegare la tensione di rete ed adottare tutti i provvedimenti necessari per impedirne il ricollegamento non intenzionale.
- Non tentare di aprire, di modificare o di riparare da soli l'apparecchio.
- Impedire la penetrazione di corpi estranei nell'apparecchio, ad esempio fermagli o altri oggetti metallici.
- Non far funzionare l'apparecchio in un ambiente umido. Non far funzionare l'apparecchio in un ambiente soggetto alla formazione di condensa o di rugiada.
- Non toccare quando acceso e subito dopo lo spegnimento. La superficie calda può causare scottature.

Vor Inbetriebnahme lesen!

Deutsch

Bitte lesen Sie diese Warnungen und Hinweise sorgfältig durch, bevor Sie das Gerät in Betrieb nehmen. Bewahren Sie die Anleitung zum Nachlesen auf. Das Gerät darf nur durch fachkundiges und qualifiziertes Personal installiert werden. Bei Funktionsstörungen oder Beschädigungen schalten Sie sofort die Versorgungsspannung ab und senden das Gerät zur Überprüfung ins Werk. Das Gerät beinhaltet keine Servicebauteile. Die angegebenen Daten dienen allein der Produktbeschreibung und sind nicht als zugesicherte Eigenschaften im Rechtssinne aufzufassen. Im Zweifelsfall gilt der englische Text.

⚠ WARNUNG Missachtung nachfolgender Punkte kann einen elektrischen Schlag, Brände, schwere Unfälle oder Tod zur Folge haben:

- Schalten Sie die Eingangsspannung vor Installations-, Wartungs- oder Änderungsarbeiten ab und sichern Sie diese gegen unbeabsichtigtes Wiedereinschalten.
- Führen Sie keine Änderungen oder Reparaturversuche am Gerät durch. Gerät nicht öffnen!
- Verhindern Sie das Eindringen von Fremdkörpern, wie z.B. Büroklammern und Metallteilen.
- Betreiben Sie das Gerät nicht in feuchter Umgebung oder in einer Umgebung, bei der mit Betauung oder Kondensation zu rechnen ist.
- Gehäuse nicht während des Betriebes oder kurz nach dem Abschalten berühren. Heiße Oberflächen können Verletzungen verursachen.

Lea primero!

Español

Conserve este manual como referencia para futuras consultas. La fuente de alimentación solo puede ser instalada y puesta en funcionamiento por personal cualificado. Por favor lea detenidamente este manual antes de conectar la fuente de alimentación. Si se produce un fallo o mal funcionamiento durante la operación, desconecte inmediatamente la tensión de alimentación. En ambos casos, el equipo debe ser inspeccionado en fábrica. La información presentada en este documento es exacta y fiable en cuanto a la descripción del producto y puede cambiar sin aviso. En casa de duda, prevalece el texto inglés.

⚠ ADVERTENCIA Riesgo de descarga eléctrica, incendio, accidente grave o muerte:

- Desconectar la tensión de red antes de trabajar en la fuente de alimentación. Evite una posible reconexión involuntaria.
- No realizar ninguna modificación o reparación de la unidad. No abrir la unidad.
- Evitar la introducción en la carcasa de objetos extraños.
- No usar el equipo en ambientes húmedos. No operar el equipo en ambientes donde se espere la formación de rocío o condensación.
- No tocar durante el funcionamiento ni inmediatamente después del apagado. El calor de la superficie puede causar quemaduras graves.

Leia primeiro!

Português

Recomendamos a leitura cuidadosa das seguintes advertências e observações, antes de colocar em funcionamento a fonte de alimentação. Guarde as Instruções para futura consulta, em casos de dúvida. A fonte de alimentação deverá ser instalada apenas por profissionais da área, tecnicamente qualificados. Se por acaso, durante a utilização ocorrer algum defeito de funcionamento ou dano, desligue imediatamente a tensão de alimentação. Em ambos os casos, será necessária uma verificação na Fábrica! Os dados mencionados têm como finalidade somente a descrição do produto, e não devem ser interpretados como propriedades garantidas no sentido jurídico. Em caso de dúvidas aplica-se o texto em inglês.

⚠ ATENÇÃO A não observância ou o incumprimento dos pontos a seguir mencionados, poderá causar uma descarga elétrica, incêndios, acidentes graves ou morte:

- Antes de trabalhos de instalação, manutenção ou modificação, desligue a tensão de alimentação, protegendo-a contra uma nova ligação involuntária.
- Não efectue nenhuma modificação ou tentativa de reparação no aparelho. Quando necessário contacte o seu distribuidor. Não abra o aparelho.
- Proteger a fonte de alimentação contra a introdução inadvertida de corpos metálicos, como por ex., cliques ou outras peças de metal.
- Não usar o aparelho em ambientes húmidos. Não usar o aparelho em ambientes propensos a condensações.
- Não tocar enquanto estiver em funcionamento, nem após a desligar. A superfície poderá estar quente e provocar lesões.

Headquarters: PULS GmbH, Elektrastr. 6, 81925 Munich, Germany, www.pulspower.com

Germany +49 89 9278 0
China +86 512 62881820

France +33 478 668 941
North America +1 630 587 9780

Austria +43 2764 3213
Singapore +65 6684 2310

Switzerland +41 56 450 18 10
United Kingdom +44 1525 841001

The information in this document is believed to be accurate and reliable and may change without notice.

Product Description

The YR20.246 is a redundancy module for building redundant power supply systems. It is equipped with two input channels and one output. The two inputs are decoupled by MOSFET technology. The device is equipped with an automated load sharing feature, which can compensate a small voltage imbalance between the power supplies connected to the inputs in order to achieve an even current share. It also monitors the function of the redundancy circuitry and provides a signal in case of a failure or a high output current, which could prevent redundancy if one power supply fails.

Intended Use

This device is designed for installation in an enclosure and is intended for commercial use, such as in industrial control, process control, monitoring and measurement equipment or the like. Do not use this device in equipment where malfunction may cause severe personal injury or threaten human life. The redundancy module can be used with any type of power supply as long as the maximum output current ratings are not exceeded. It is suitable for power supplies with continuous overload current as well as any kind of intermittent (Hiccup) overload behavior.

Installation Instructions

Install the device in an enclosure providing protection against electrical, mechanical and fire hazards. Do not ground or earth the positive output pole which could prevent redundancy in case of a ground failure. Ground the negative output pole, when needed.

Use only power supplies with a negligible output ripple voltage in the low frequency range between 50Hz and 10kHz when used in marine applications according to the GL regulations.

Install the device onto a DIN-rail according to EN 60715 with the output terminals on the bottom of the device. Other mounting orientations require a reduction in output current.

Make sure that the wiring is correct by following all local and national codes. Use appropriate copper cables that are designed for a minimum operating temperature of 60°C for ambient temperatures, up to +45°C, 75°C for ambient temperatures up to +60°C and 90°C for ambient temperatures up to +70°C. Ensure that all strands of a stranded wire enter the terminal connection. Unused screw terminals should be securely tightened.

The device is designed for pollution degree 2 areas in controlled environments. No condensation or frost is allowed.

The enclosure of the device provides a degree of protection of IP20.

The input must be powered from a PELV or SELV source or an "Isolated Secondary Circuit" in order to maintain a SELV or PELV output.

Check correct input polarity. The device will not operate when input voltage is reversed.

The device is designed as "Class of Protection III" equipment according to IEC 61140.

A PE (ground) connection is not required. However, connecting the chassis ground terminal to ground can be beneficial to gain a high EMI immunity.

The device is designed for convection cooling and does not require an external fan. Do not obstruct airflow and do not cover ventilation grid!

The device is designed for altitudes up to 6000m (19685ft). See additional requirements in the product datasheet for use above 2000m (6560ft).

Keep the following minimum installation clearances: 40mm on top, 20mm on the bottom, 5mm left and right side. Increase the 5mm to 15mm in case the adjacent device is a heat source. When the device is permanently loaded with less than 50%, the 5mm can be reduced to zero. Under special circumstances clearances can be reduced. See details in the product datasheet.

The maximum surrounding air temperature is +70°C (+158°F). The operational temperature is the same as the ambient or surrounding air temperature and is defined 2cm below the device.

The device is designed to operate in areas between 5% and 95% relative humidity.

To ensure a proper load share function, ensure that the wiring size and length between the two power supplies and the redundancy module is identical.

Installation Instructions for Hazardous Location Areas

The device is suitable for use in Class I Division 2 Groups A, B, C, D locations and for use in Group II Category 3 (Zone 2) environments.

Hazardous Location classification: ATEX: EPS 11 ATEX 1 312 X, II 3G EX ec nC IIC T4 Gc

WARNING EXPLOSION HAZARDS!

Substitution of components may impair suitability for this environment.

Do not disconnect the device unless power has been switched off or the area is known to be non-hazardous.

A suitable enclosure must be provided for the end product which has a minimum protection of IP54 and fulfills the requirements of the EN 60079-0.

Functional Description

The device can supply any kind of loads, including unlimited capacitive and inductive loads.

Do not apply return voltages from the load to the output of the redundancy module higher than 40Vdc.

Automated load share function and "Load Share OK" relay contact.

When installing the devices, adjust the power supply voltages that only the green LED in the middle is on (area 1 of the diagram). Area 2 indicates that the redundancy module operates within the automated load share range and area 3 indicates that load sharing is not possible, which is also reported through the "Load Share OK" relay contact (contact is open).

Selector for output current warning threshold and "Output current < I_N" LED

If the output current increases, e. g. due to additional loads, and exceeds the nominal current of one power supply, redundancy is no longer guaranteed. Therefore, the output current is monitored and is reported through a LED (Output current < I_N) and a relay contact (Redundancy OK) when exceeding the predefined value.

Set the selector to 5A used with two 5A or 10A when used with two 10A power supplies (1+1 redundancy). Set the selector to 20A for n+1 redundant systems. With a 20A setting, redundancy cannot be checked by the redundancy module.

Relay contact "Redundancy OK"

The relay contact is closed when no redundancy errors are detected. The relay contact is synchronized with the "Redundancy OK" LED. The contact is open when one or both input voltages are below 22Vdc or above 30Vdc. It is also open when the output current is higher than the adjusted value of the output current threshold setting, or an internal defect of the module is detected.

Technical data

All values are typical figures specified at 24Vdc input voltage, 20A output current, 25°C ambient temperature and after a 5 minutes run-in time unless otherwise noted.

Input voltage	DC 24-28V	±25%
Input voltage range	18 – 35Vdc	
Input current	2x 12A	Below +45°C ambient
	2x 10A	At +70°C ambient
	Derate linearly between +45 and +70°C	
Output current	24A	Below +45°C ambient
	20A	At +70°C ambient
Maximum output current below 6Vdc	26A R.M.S.	In any overload or short circuit condition
Input to output voltage loss	0.1-0.5V	At 2x 5A input
	0.2-0.5V	At 2x 10A input
	Depending on load share function	
Power losses	1.7W	At no load
	2.6-4.7W	At 2x 5A input
	5.6-8.7W	At 2x 10A input
	Depending on load share function	
Temperature range	-40°C to +70°C	
Max. wire size (lit wire)	4mm ²	Power terminals
Wire size AWG	AWG 20-10	Power terminals
Max. wire diameter	2.8mm	Power terminals
Wire stripping length	7mm / 0.28inch	Power terminals
Tightening torque	1Nm / 9lb.inch	Power terminals
Max. wire size (lit wire)	1.5mm ²	Signal terminals
Wire size AWG	AWG 24-16	Signal terminals
Max. wire diameter	1.6mm	Signal terminals
Wire stripping length	7mm / 0.28inch	Signal terminals
Size (wxhxd)	32x124x117mm	Without DIN-rail
Weight	310g / 0.69lb	

Functional diagram

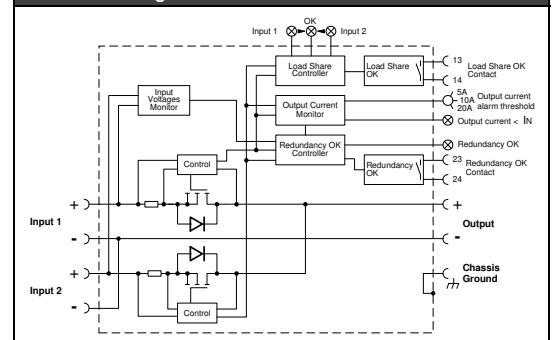

Wiring scheme - 1+1 redundancy

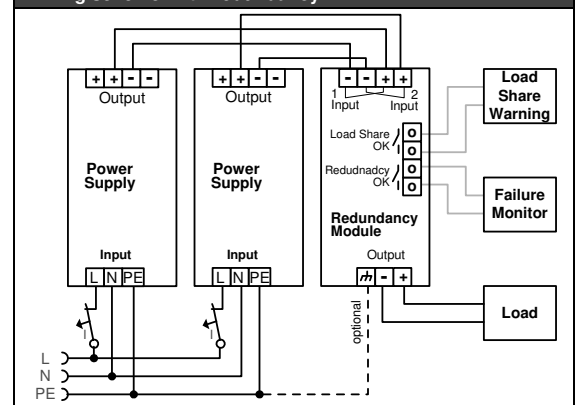

Automated load share function

