



Chipsmall Limited consists of a professional team with an average of over 10 year of expertise in the distribution of electronic components. Based in Hongkong, we have already established firm and mutual-benefit business relationships with customers from,Europe,America and south Asia,supplying obsolete and hard-to-find components to meet their specific needs.

With the principle of “Quality Parts,Customers Priority,Honest Operation,and Considerate Service”,our business mainly focus on the distribution of electronic components. Line cards we deal with include Microchip,ALPS,ROHM,Xilinx,Pulse,ON,Everlight and Freescale. Main products comprise IC,Modules,Potentiometer,IC Socket,Relay,Connector.Our parts cover such applications as commercial,industrial, and automotives areas.

We are looking forward to setting up business relationship with you and hope to provide you with the best service and solution. Let us make a better world for our industry!



Contact us

Tel: +86-755-8981 8866 Fax: +86-755-8427 6832

Email & Skype: info@chipsmall.com Web: www.chipsmall.com

Address: A1208, Overseas Decoration Building, #122 Zhenhua RD., Futian, Shenzhen, China





MOSFET REDUNDANCY MODULE

- Single Input with Single Output
- Equipped with Plug-connector for "Hot Swapping"
- Suitable for all DIMENSION Power Supplies Except QT40 Series
- Only 150mV Voltage Drop at 40A
- Only 6.2W at 40A
- 160% (65A) Peak Load Capability
- Reverse Input Polarity Protection
- Full Power Between -40°C and +60°C
- Width only 46mm
- Rugged Metal Housing
- Easy Wiring:
Distribution Terminal for Negative Pole Included
- 3 Year Warranty

GENERAL DESCRIPTION

The YR40.245 is a redundancy module, which can be used to build redundant systems. The module has one input and one output and can carry nominal currents up to 40A. The output is equipped with a plug-connector, which allows replacing the power supply or the redundancy module while the system is running (hot-swapping)

The novelty of this redundancy module is the utilization of mosfets instead of diodes for the decoupling of the two input channels. This reduces the heat generation and the voltage drop between input and output. The redundancy module does not require an additional auxiliary voltage.

Due to the low power losses, the unit is very slender and only requires 46mm width on the DIN-rail. Large connection terminals allow for a safe and fast installation. The large international approval package makes this unit suitable for nearly every application.

SHORT-FORM DATA

Input voltage	DC 12-28V	±30%
Input voltage range	8.4-36.4Vdc	
Input current	0-40A 40-65A	continuous for 5 seconds
Output current	0-40A 40-65A max. 22A	continuous for 5 seconds in overload ^{*)} or short circuit mode
Input to output voltage drop	typ. 80mV typ. 150mV	at 20A at 40A
Power losses	typ. 120mW typ. 1.8W typ. 6.2W	at no load at 24V, 20A at 24V, 40A
Temperature range	-40°C to +70°C	operational
Derating	1A/°C	+60 to +70°C
Dimensions ^{*)}	46x124x127mm	WxHxD
Weight	340g, 0.75lb	

*) Currents at voltages below 6V

**) Plus height for plug connector

ORDER NUMBERS

Redundancy Module	YR40.245	12-28V Standard unit
Accessory	ZM2.WALL	Wall/ panel mount bracket
	ZM12.SIDE	Side mount bracket

MARKINGS



INDEX

	Page		Page
1. Intended Use	3	14. Dielectric Strength.....	12
2. Installation Requirements.....	3	15. Approvals.....	13
3. Input and Output Characteristics	4	16. Physical Dimensions and Weight.....	14
4. Power Losses.....	5	17. Accessories	15
5. Lifetime Expectancy and MTBF.....	6	18. Application Notes.....	16
6. Terminals and Wiring.....	7	18.1. Recommendations for Redundancy.....	16
7. Replacing Units while the System is Running	8	18.2. Inductive and Capacitive Loads.....	16
8. Functional Diagram.....	9	18.3. Sideways Installation Clearances.....	16
9. Front Side and User Elements.....	9	18.4. 1+1 Redundancy up to 40A.....	17
10. EMC.....	10	18.5. N+1 Redundancy, Example with 120A	17
11. Environment.....	11	18.6. Mounting Orientations	18
12. Protection Features	12		
13. Safety Features	12		

The information presented in this document is believed to be accurate and reliable and may change without notice. No part of this document may be reproduced or utilized in any form without permission in writing from the publisher.

TERMINOLOGY AND ABBREVIATIONS

PE and \oplus symbol	PE is the abbreviation for Protective Earth and has the same meaning as the symbol \oplus .
Earth, Ground	This document uses the term "earth" which is the same as the U.S. term "ground".
T.b.d.	To be defined, value or description will follow later.
DC 24V	A figure displayed with the AC or DC before the value represents a nominal voltage with standard tolerances (usually $\pm 15\%$) included. E.g.: DC 12V describes a 12V battery disregarding whether it is full (13.7V) or flat (10V)
24Vdc	A figure with the unit (Vdc) at the end is a momentary figure without any additional tolerances included.
may	A key word indicating flexibility of choice with no implied preference
shall	A key word indicating a mandatory requirement
should	A key word indicating flexibility of choice with a strongly preferred implementation
1+1 Redundancy	Use of two identical power supplies in parallel to provide continued operation following most failures in a single power supply. The two power supply outputs should be isolated from each other by utilizing diodes or other switching arrangements. E.g. two 10A power supplies are needed to achieve a 10A redundant system.
N+1 Redundancy	Use of three or more identical power supplies in parallel to provide continued operation following most failures in a single power supply. All power supply outputs should be isolated from each other by utilizing diodes or other switching arrangements. E.g.: To achieve a 30A redundant system, four 10A power supplies are needed in a N+1 redundant system.

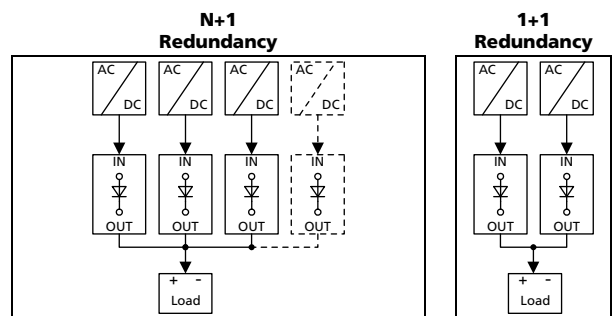

1. INTENDED USE

This redundancy module is designed for installation in an enclosure and is intended for the general use such as in industrial control, office, communication, and instrumentation equipment.

This redundancy module can be used with any DIMENSION power supplies except the QT40 series.

Do not use this redundancy module in equipment, where malfunction may cause severe personal injury or threaten human life.

This device is designed for use in hazardous, non-hazardous, ordinary or unclassified locations.

2. INSTALLATION REQUIREMENTS

This device may only be installed and put into operation by qualified personnel.

This device does not contain serviceable parts.

If damage or malfunction should occur during installation or operation, immediately turn power off and send unit to the factory for inspection.

Mount the unit on a DIN-rail so that the input terminals are located on the bottom and the output terminals on the top of the unit. For other mounting orientations see de-rating requirements of chapter 18.6 in this document.

This device is designed for convection cooling and does not require an external fan. Do not obstruct airflow and do not cover the ventilation grid (e.g. cable conduits) by more than 30%!

Keep the following installation clearances:

40mm on top,

20mm on the bottom,

5mm on the left and right sides are recommended when the device is loaded permanently with more than 50% of the rated output current. Increase the side clearance to 15mm in case the adjacent device is a heat source (e.g. another power supply). See chapter 18.3 for other allowed clearances when used with the PULS DIMENSION series in a 1+1 redundant configuration.

Use only power supplies with a negligible output ripple voltage in the low frequency range between 50Hz and 10kHz when used in marine applications according to the GL regulations.

⚠ WARNING Risk of electrical shock, fire, personal injury or death.

- Turn power off before working on the device. Protect against inadvertent re-powering.
- Make sure that the wiring is correct by following all local and national codes.
- Do not open, modify or repair the unit.
- Use caution to prevent any foreign objects from entering the housing.
- Do not use in wet locations or in areas where moisture or condensation can be expected.
- Do not touch during power-on, and immediately after power-off. Hot surfaces may cause burns.

Notes for use in hazardous location areas:

The redundancy module is suitable for use in Class I Division 2 Groups A, B, C, D locations and for use in Group II Category 3 (Zone 2) environments and is evaluated according to EN 60079-0:2009 and EN 60079-15:2010.

WARNING EXPLOSION HAZARDS!

Substitution of components may impair suitability for this environment. Do not disconnect the unit unless power has been switched off or the area is known to be non-hazardous.

A suitable enclosure must be provided for the end product which has a minimum protection of IP54 and fulfils the requirements of the EN 60079-15:2010.

3. INPUT AND OUTPUT CHARACTERISTICS

Number of inputs	-	1	
Number of outputs	-	1	
Input voltage	nom.	DC 12-28V \pm 30%	The input circuitry must meet the SELV requirements stipulated by IEC/EN/UL 60950-1.
Input voltage range	-	8.4-36.4Vdc	
Voltage drop, input to output	typ.	80mV	at 20A, see Fig. 3-1
	typ.	150mV	at 40A, see Fig. 3-1
Input current	nom.	0-40A	continuous
	nom.	40-65A	for 5 seconds
	max	22A	in overload (voltage < 6V) or short circuit mode
Peak input current	max.	1500A	for max. 1ms per input
Output current	nom.	40A	continuous
	nom.	40-65A	for 5 seconds
	max.	22A	in overload (voltage < 6V) or short circuit mode
Reverse current	max.	1mA	at 24V, per input, -40°C to +70°C
Reverse voltage	max.	40Vdc	voltage applied to the output, continuously allowed
Output capacitance	typ.	320 μ F	

Fig. 3-1 **Input to output voltage drop when both inputs draw current**
(typical 1+1 redundant case, when the output voltages of the two units are equal)

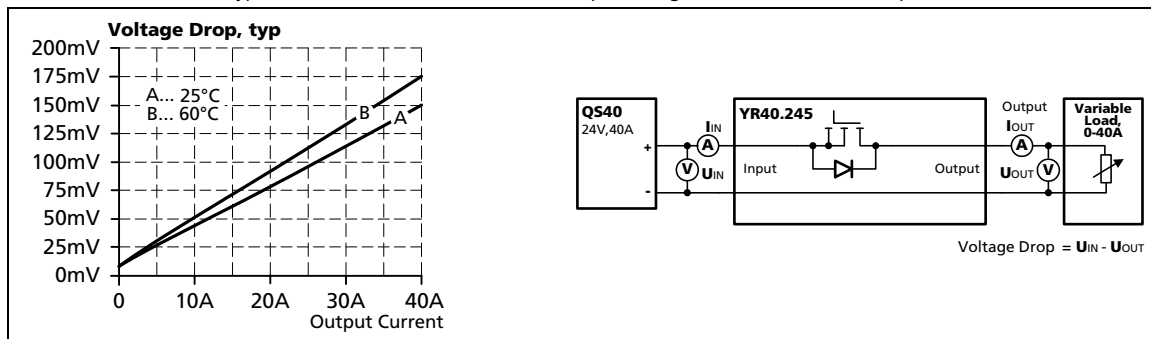

4. POWER LOSSES

		DC 12V	DC 24V	
Power losses	typ.	1.7W	1.8W	at 20A
	typ.	6.1W	6.2W	at 40A
Standby power losses	typ.	0.06W	0.12W	at no output current

Fig. 4-1 Power losses when both inputs draw equal current

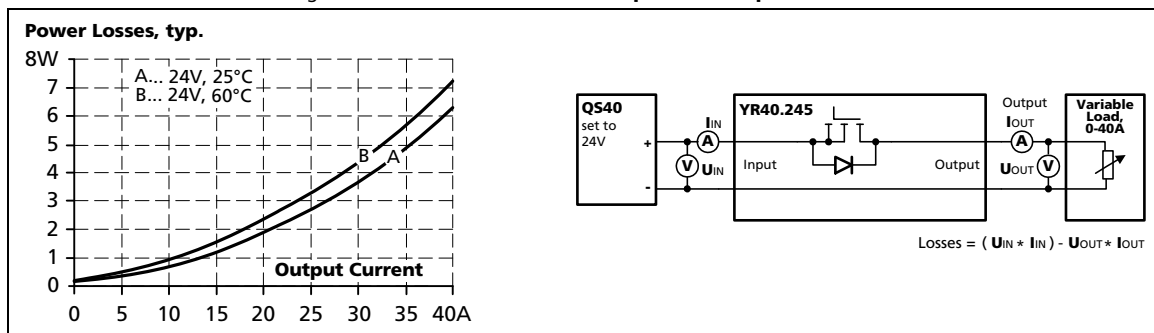

5. LIFETIME EXPECTANCY AND MTBF

Load conditions	Output: 20A	Output: 40A	
Lifetime expectancy *)	557 000h *)	134 000h *)	at 24V and 40°C
	1 576 000h *)	378 000h *)	at 24V and 25°C
MTBF **) SN 29500, IEC 61709	13 290 000h	6 357 000h	at 24V 40°C
	22 628 000h	12 238 000h	at 24V 25°C
MTBF **) MIL HDBK 217F	381 000h	278 000h	Ground Fixed GF40 (24V and 40°C)
	518 000h	366 000h	Ground Fixed GF25 (24V and 25°C)
	1 816 000h	1 401 000h	Ground Benign GB40 (24V and 40°C)
	2 486 000h	1 861 000h	Ground Benign GB25 (24V and 25°C)

*) The **Lifetime expectancy** shown in the table indicates the minimum operating hours (service life) and is determined by the lifetime expectancy of the built-in electrolytic capacitors. Lifetime expectancy is specified in operational hours and is calculated according to the capacitor's manufacturer specification. The manufacturer of the electrolytic capacitors only guarantees a maximum life of up to 15 years (131 400h). Any number exceeding this value is a calculated theoretical lifetime which can be used to compare devices.

) **MTBF stands for **Mean Time Between Failure**, which is calculated according to statistical device failures, and indicates reliability of a device. It is the statistical representation of the likelihood of a unit to fail and does not necessarily represent the life of a product. The MTBF figure is a statistical representation of the likelihood of a device to fail. A MTBF figure of e.g. 1 000 000h means that statistically one unit will fail every 100 hours if 10 000 units are installed in the field. However, it can not be determined if the failed unit has been running for 50 000h or only for 100h.

6. TERMINALS AND WIRING

	Input	Output
Type	Screw termination IP20 Finger safe construction. Suitable for field installation.	Pluggable screw termination IP20 Finger safe construction. Suitable for field installation.
Solid wire	0.5-16mm ²	0.2-16mm ²
Stranded wire	0.5-10mm ²	0.5-10mm ²
American Wire Gauge	22-8 AWG	22-6 AWG
Max. wire diameter	5.2mm (including ferrule)	5.4mm (including ferrule)
Wire stripping length	12mm / 0.5inch	12mm / 0.5inch
Screwdriver	3.5x1mm slotted or Pozidrive No 2	5.5x1mm slotted or Pozidrive No 2
Recommended tightening torque	1.2Nm, 10.6lb-in	1.4Nm, 12lb-in

To connect the chassis to ground, use a ring-type terminal (ring cable lug) which is suitable for a M4 screw and connect it to the chassis ground terminal on top of the unit.

Instructions:

- The external circuitry of all terminals must meet the safety requirements stipulated by IEC/EN/UL 60950-1: SELV.
- Use appropriate copper cables that are designed for minimum operating temperatures of:
 - 60°C for ambient up to 45°C and
 - 75°C for ambient up to 60°C and
 - 90°C for ambient up to 70°C minimum.
- Follow national installation codes and installation regulations!
- Ensure that all strands of a stranded wire enter the terminal connection!
- Screws of unused terminal compartments should be securely tightened.
- Ferrules are allowed.
- Do not connect or disconnect the wires from the terminals below -25°C (-13°F).

Instructions for inserting and removing the pluggable output terminal

To avoid an accidental disconnection of the output, the plug connector is equipped with a locking system.

Fig. 6-1 Removing the latch mechanism

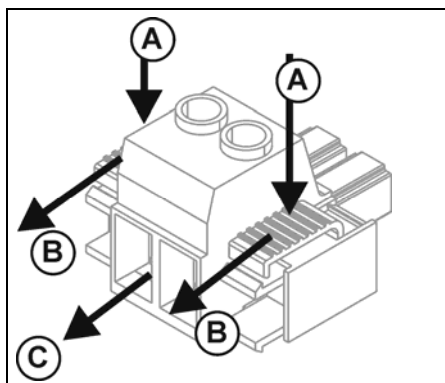

- A** Unlock the red sliders by pushing the tabs down
- B** At the same time slide the tabs back
- C** Pull-out to unplug the connector

To insert the plug connector, reverse the procedure

7. REPLACING UNITS WHILE THE SYSTEM IS RUNNING

Fig. 7-1 Replacing the power supply or redundancy module while the system is running

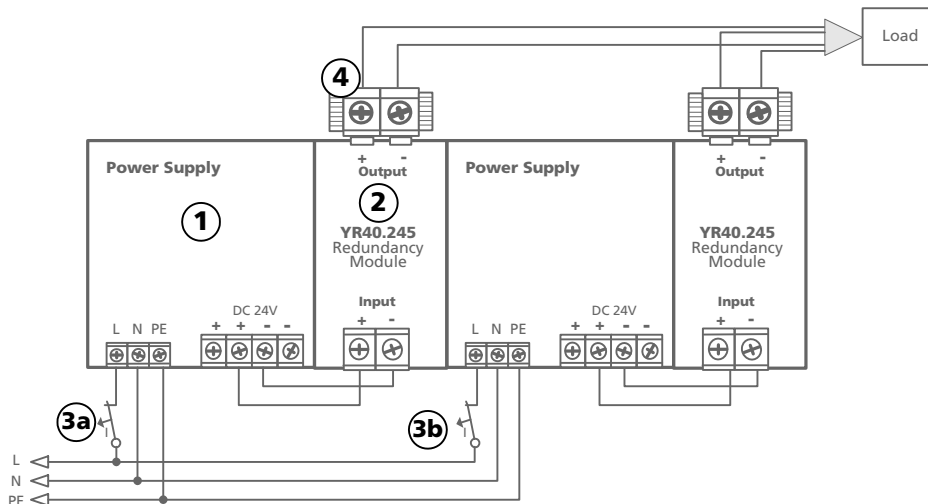

Instructions:

- Switch-off circuit breaker (3a).
- Remove plug (4). The plug prevents the cables from shorting.
- Change power supply (1) or/ and redundancy module (2).
- Put the plug (4) back in.
- Turn-on the circuit breaker (3a).
- The circuit is redundant again.

To replace the right power supply or redundancy module, use the same procedure but turn off circuit breaker (3b).

8. FUNCTIONAL DIAGRAM

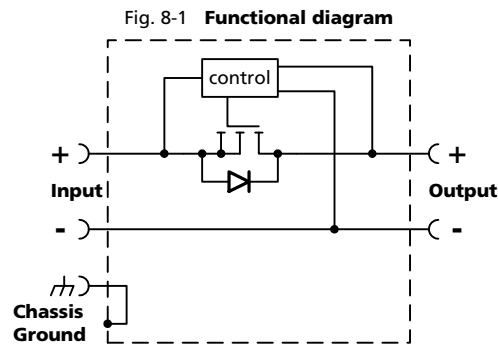

9. FRONT SIDE AND USER ELEMENTS

Fig. 9-1 **Front side**



A Output Terminals (pluggable screw terminals)

B Chassis Ground Terminals

To be connected on the top side of the housing with a ring-type terminal (ring cable lug) which is suitable for a M4 screw. Connection of the chassis is optional and not required since the unit fulfils the requirements according to protection class III.

C Input Terminals (screw terminals)

10. EMC

The redundancy module is suitable for applications in industrial environment as well as in residential, commercial and light industry environment without any restrictions. A detailed EMC report is available on request.

EMC Immunity	According generic standards: EN 61000-6-1 and EN 61000-6-2			
Electrostatic discharge	EN 61000-4-2	Contact discharge	8kV	Criterion A
		Air discharge	15kV	Criterion A
Electromagnetic RF field	EN 61000-4-3	80MHz-2.7GHz	20V/m	Criterion A
Fast transients (Burst)	EN 61000-4-4	Input lines	2kV	Criterion A
		Output lines	2kV	Criterion A
Surge voltage on input lines	EN 61000-4-5	+ → -	500V	Criterion A
		+/- → Chassis ground	1kV	Criterion A
Surge voltage on output lines	EN 61000-4-5	+ → -	500V	Criterion A
		+/- → Chassis ground	1kV	Criterion A
Conducted disturbance	EN 61000-4-6	0.15-80MHz	20V	Criterion A
Power-frequency magnetic field *)	EN 61000-4-8	50Hz	30A/m	Criterion A

Criteria:

A: Redundancy module shows normal operation behavior within the defined limits.

Notes:

*) A test is not applicable according to EN 61000-6-2, since the device does not contain components susceptible to magnetic fields, e.g. hall elements, electrodynamic microphones, etc.

EMC Emission	According generic standards: EN 61000-6-3 and EN 61000-6-4	
Conducted emission	IEC/CISPR 16-1-2, IEC/CISPR 16-2-1	limits for DC power ports according EN 61000-6-3 fulfilled *)
Radiated emission	EN 55011, EN 55022	Class B

This device complies with FCC Part 15 rules.

Operation is subjected to following two conditions: (1) this device may not cause harmful interference, and (2) this device must accept any interference received, including interference that may cause undesired operation.

*) For information only, not mandatory for EN 61000-6-3. Provided, that power sources connected on the inputs fulfill the requirements too.

Switching frequency The internal auxiliary supply is generated with a boost converter.
The switching frequency varies from 140kHz to 500kHz depending on the input voltage.

11. ENVIRONMENT

Operational temperature *)	-40°C to +70°C (-40°F to 158°F)	
Storage temperature	-40 to +85°C (-40°F to 185°F)	for storage and transportation
Output de-rating	1A / °C	60-70°C (140°F to 158°F)
Humidity **)	5 to 95% r.H.	IEC 60068-2-30
Vibration sinusoidal ***)	2-17.8Hz: ±1.6mm; 17.8-500Hz: 2g 2 hours / axis	IEC 60068-2-6
Shock ***)	30g 6ms, 20g 11ms 3 bumps / direction, 18 bumps in total	IEC 60068-2-27
Altitude	0 to 2000m (0 to 6 560ft) 2000 to 6000m (6 560 to 20 000ft)	without any restrictions reduce output power or ambient temperature, see Fig. 11-2
Altitude de-rating	2.5A/1000m or 5°C/1000m	> 2000m (6500ft), see Fig. 11-2
Over-voltage category	not applicable	The concept of the overvoltage category is used for equipment energized directly from the low voltage mains (IEC 60664-1 §4.3.3.2.1).
Degree of pollution	2	IEC 62103, EN 50178, not conductive
LABS compatibility	The unit does not release any silicone or other LABS-critical substances and is suitable for use in paint shops.	

*) Operational temperature is the same as the ambient temperature and is defined as the air temperature 2cm below the unit.

**) Do not energize while condensation is present

***) Tested in combination with DIN-Rails according to EN 60715 with a height of 15mm and a thickness of 1.3mm and standard mounting orientation.

Fig. 11-1 Output current vs. ambient temp.

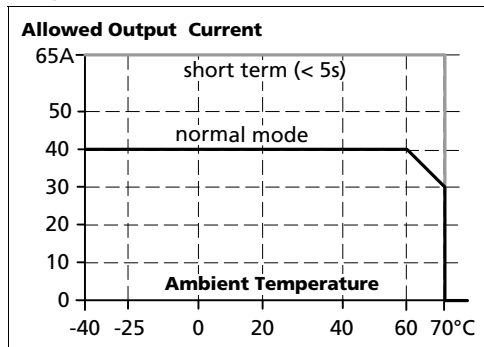
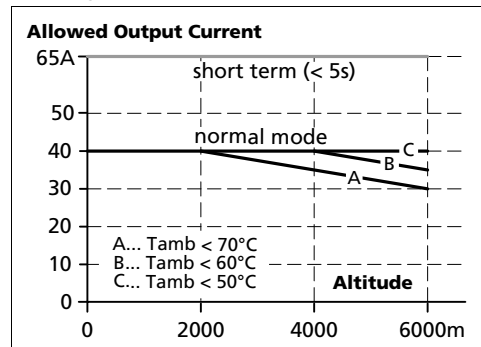

Fig. 11-2 Output current vs. altitude



12. PROTECTION FEATURES

Output over-current protection	not included	
Reverse input polarity protection	included	unit does not start when input voltage is reversed
Degree of protection	IP 20	EN/IEC 60529
Penetration protection	> 3.6mm	e.g. screws, small parts
Over-temperature protection	not included	
Input transient protection	not included	
Output transient protection	included	see EMC section
Internal input fuse	not included	

13. SAFETY FEATURES

Input / output separation	no galvanic separation	Mosfet between input and output
Class of protection	III	PE (Protective Earth) or chassis connection not required
PE resistance	< 0.10hm	between housing and chassis-ground terminal

14. DIELECTRIC STRENGTH

The input and output voltages have the same reference, are floating and have no ohmic connection to ground. Type and factory tests are conducted by the manufacturer. Field tests may be conducted in the field using the appropriate test equipment which applies the voltage with a slow ramp (2s up and 2s down). Connect input/output terminals together before conducting the test.





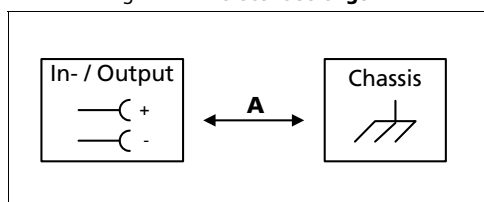





When testing, set the cut-off current settings to the value in the table below.

Fig. 14-1 Dielectric strength



	A	
Type test	60s	500Vac
Factory test	5s	500Vac
Field test	5s	500Vac
Cut-off current setting	> 2mA	

15. APPROVALS

EC Declaration of Conformity		The CE mark indicates conformance with the - EMC directive 2004/108/EC, - Low-voltage directive (LVD) 2006/95/EC and - RoHS directive 2011/65/EU.
EC Declaration of Conformity ATEX		The CE mark indicates conformance with the - ATEX directive 94/9/EC (Equipment and protection systems intended for use in potentially explosive atmospheres)
IEC 60950-1		CB Scheme, Information Technology Equipment
UL 508		Listed for use as Industrial Control Equipment; U.S.A. (UL 508) and Canada (C22.2 No. 107-1-01); E-File: E198865
UL 60950-1		Recognized for use as Information Technology Equipment, Level 5; U.S.A. (UL 60950-1) and Canada (C22.2 No. 60950); E-File: E137006
HazLoc (Class 1 Div 2) ANSI / ISA 12.12.01-2007		LISTED for use in Hazardous Location Class I Div 2 T4 Groups A,B,C,D systems; U.S.A. (ANSI / ISA 12.12.01-2007) and Canada (C22.2 No. 213-M1987)
ATEX EN 60079-0, EN 60079-15	 II 3G Ex nA IIC T4 Gc	Suitable for use in Category 3 Zone 2 locations. Number of ATEX certificate: EPS 11 ATEX 1 312 X The redundancy module must be built-in in an IP54 enclosure.
IECEX IEC 60079-0, IEC 60079-15	 Ex nA IIC T4 Gc	Suitable for use in Category 3 Zone 2 locations. Number of IECEX certificate: IECEX EPS 12.0032X
Marine		GL (Germanischer Lloyd) classified Environmental category: C, EMC1 Marine and offshore applications
GOST R		Certificate of Conformity for Russia and other GUS countries

16. PHYSICAL DIMENSIONS AND WEIGHT

Weight	340g / 0.75lb
DIN-Rail	Use 35mm DIN-rails according to EN 60715 or EN 50022 with a height of 7.5 or 15mm. The DIN-rail height must be added to the unit depth (127mm) to calculate the total required installation depth.
Installation clearances	See chapter 2

Fig. 16-1 **Front view**

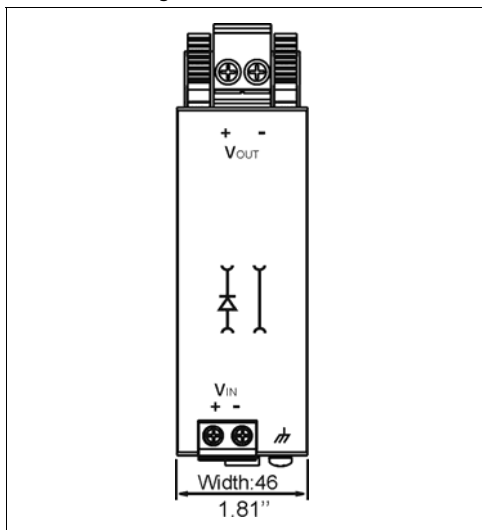
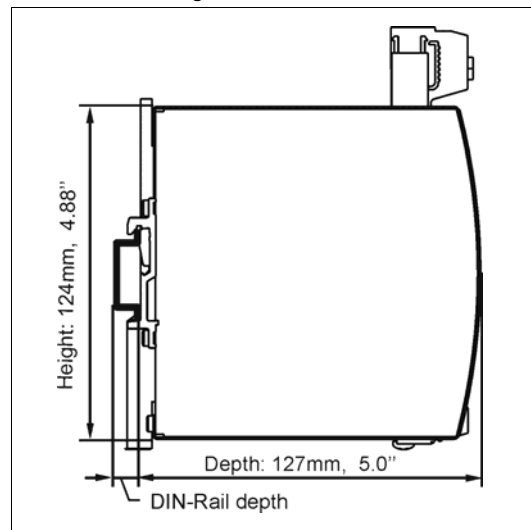

Fig. 16-2 **Side view**



17. ACCESSORIES

ZM2.WALL Wall mounting bracket

This standard bracket is used to mount the YR40.245 redundancy module onto a flat surface without utilizing a DIN-Rail.

Fig. 17-1 **ZM2.WALL Wall mounting bracket**

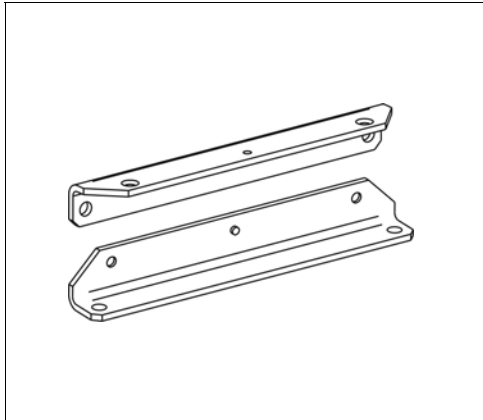
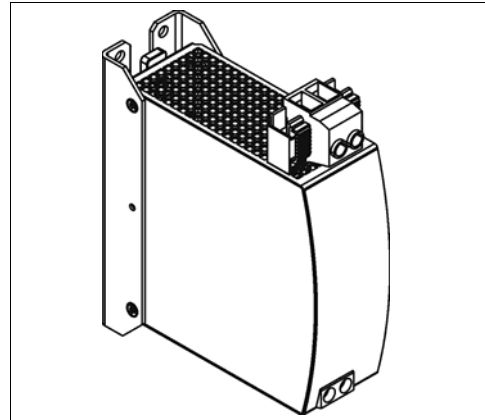

Fig. 17-2 **Assembled wall mounting bracket**



ZM12.SIDE Side mounting bracket

This bracket is used to mount the YR40.245 redundancy module sideways with or without utilizing a DIN-Rail.

The two aluminum brackets and the black plastic slider of the unit have to be detached, so that the steel brackets can be mounted.

For sideways DIN-rail mounting, the removed aluminum brackets and the black plastic slider need to be mounted on the steel bracket.

Fig. 17-3
ZM12.SIDE Side mounting bracket

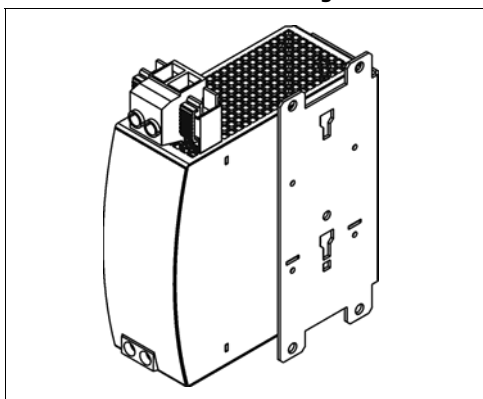
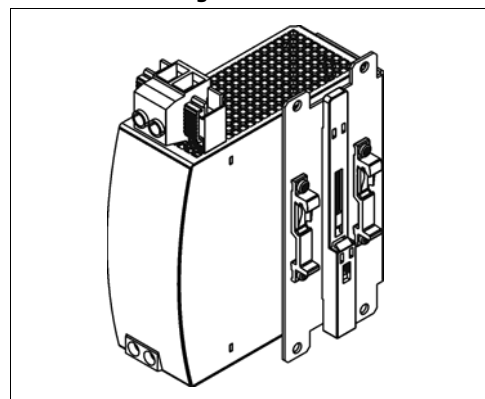

Fig. 17-4
Side mounting with DIN-rail brackets



18. APPLICATION NOTES

18.1. RECOMMENDATIONS FOR REDUNDANCY

Recommendations for the configuration of redundant power systems:

- Use separate input fuses for each power supply.
- Use three-phase power supplies to gain functional safety if one phase fails.
- When single-phase power supplies are utilized connect them to different phases or mains circuits if possible.
- Set the power supply in "Parallel-Use" mode if this feature is available
- It is desirable to set the output voltages of all power supplies to the same value.

18.2. INDUCTIVE AND CAPACITIVE LOADS

The unit is designed to supply any kind of loads, including unlimited capacitive and inductive loads.

18.3. SIDEWARDS INSTALLATION CLEARANCES

The minimum clearance recommendations are defined in chapter 2.

Normally, the following installation clearance are recommended: 40mm on top, 20mm on the bottom, 5mm on the left and right sides when the device is loaded permanently with more than 50% of the rated power. Increase this clearance to 15mm in case the adjacent device is a heat source (e.g. another power supply).

The clearance between the power supplies and the redundancy module can be reduced to zero under the following conditions:

- 1+1 redundancy application with maximum 40A output current.
- The power supplies are from the PULS DIMENSION series.
- The redundancy module is placed between the two power supplies or at least on one side of the power supply.
- The output voltage is set to the same level on both power supplies.

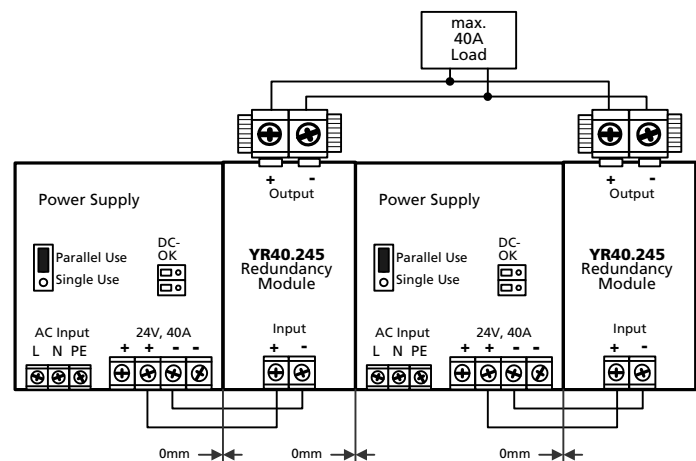

18.4. 1+1 REDUNDANCY UP TO 40A

1+1 Redundancy up to 40A requires two 40A power supplies and two YR40.245 redundancy modules.

Fig. 18-1 **Wiring diagram, 1+1 Redundancy, 40A output current**

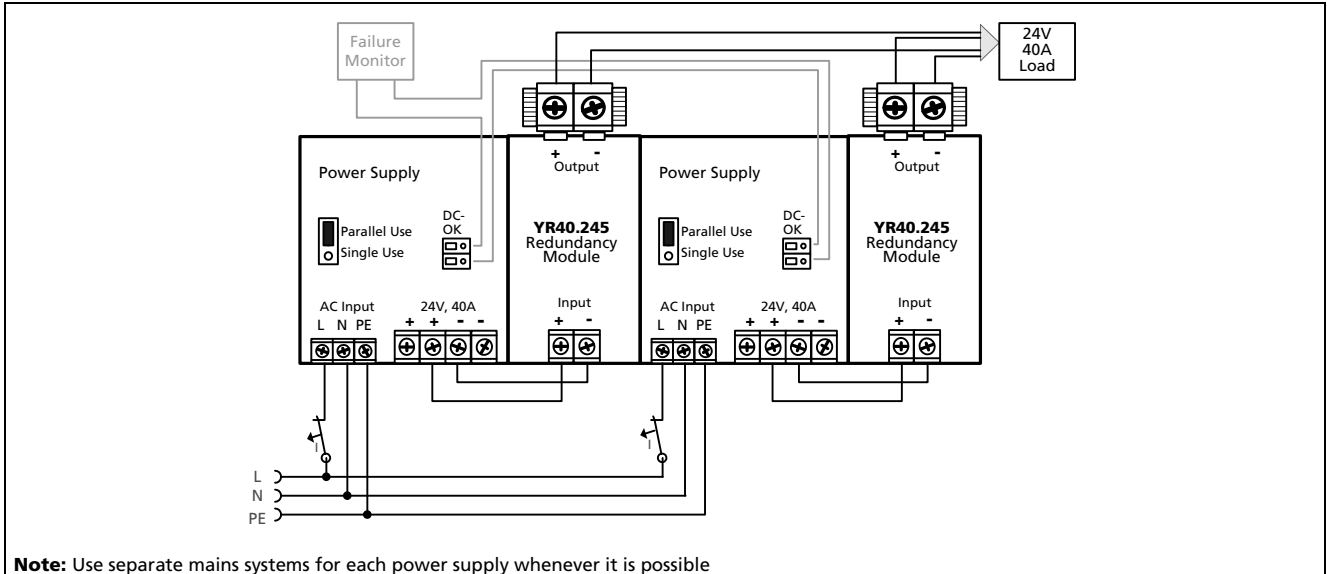

18.5. N+1 REDUNDANCY, EXAMPLE WITH 120A

N+1 Redundancy up to 120A requires four 40A power supplies and four YR40.245 redundancy modules.

Fig. 18-2 **Wiring diagram, n+1 Redundancy, 120A output current**

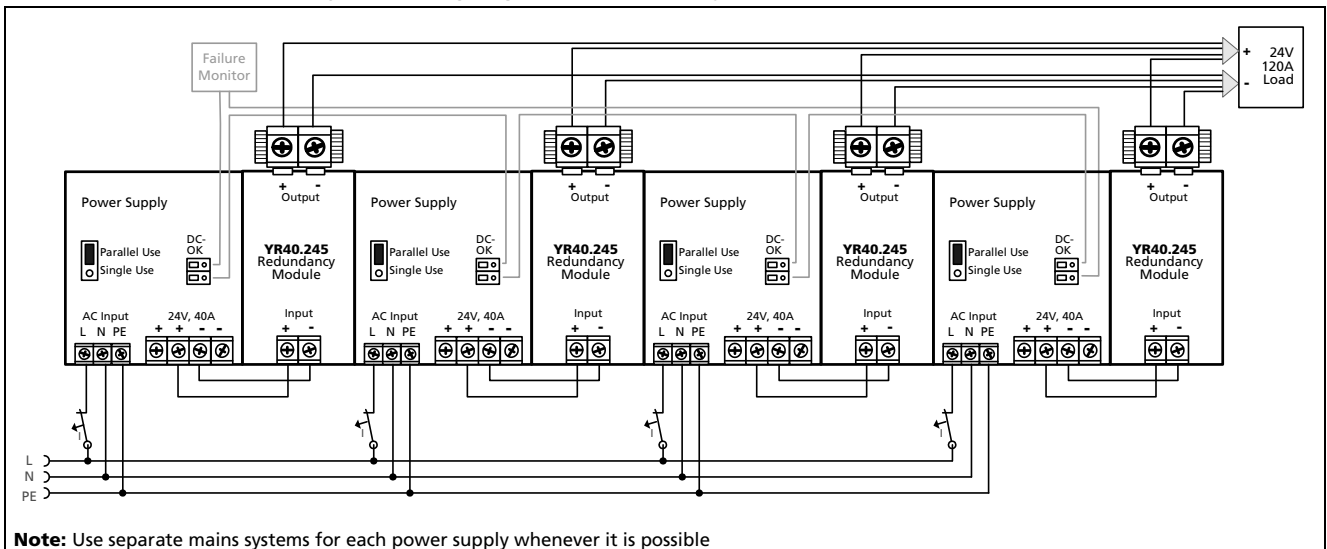

18.6. MOUNTING ORIENTATIONS

Mounting orientations other than input terminals on the bottom and output on the top require a reduction in continuous output power or a limitation in the maximum allowed ambient temperature. The amount of reduction influences the lifetime expectancy of the power supply. Therefore, two different derating curves for continuous operation can be found below:

Curve A1 Recommended output current.

Curve A2 Max allowed output current (results in approximately half the lifetime expectancy of A1).

Fig. 18-3
Mounting Orientation A
(Standard orientation)

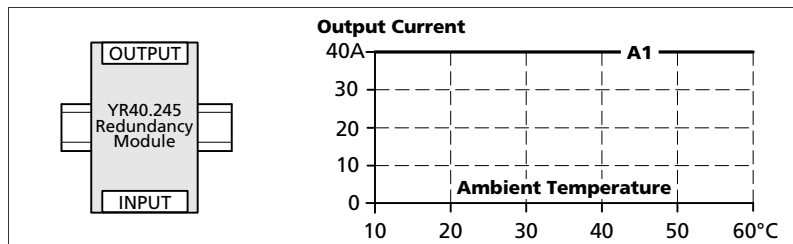

Fig. 18-4
Mounting Orientation B
(Upside down)

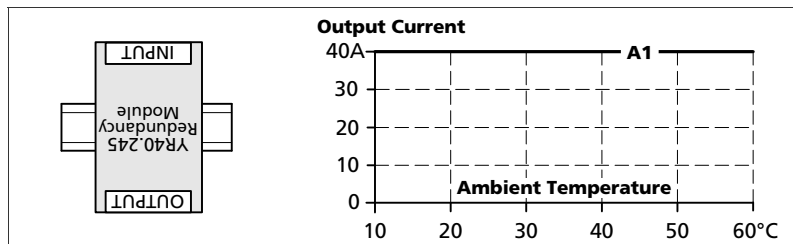

Fig. 18-5
Mounting Orientation C
(Table-top mounting)

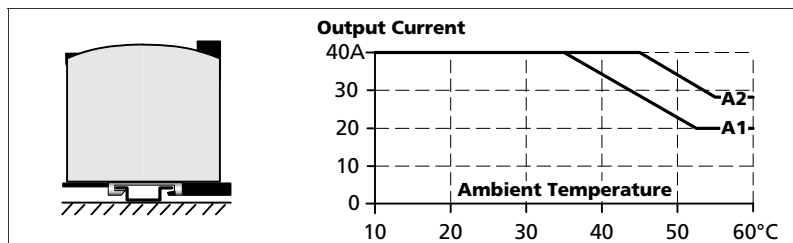

Fig. 18-6
Mounting Orientation D
(Horizontal cw)

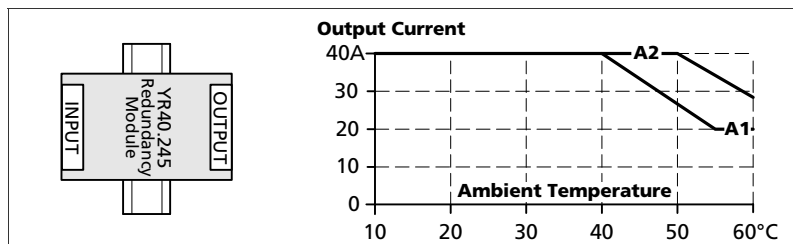

Fig. 18-7
Mounting Orientation E
(Horizontal ccw)

