



Chipsmall Limited consists of a professional team with an average of over 10 year of expertise in the distribution of electronic components. Based in Hongkong, we have already established firm and mutual-benefit business relationships with customers from,Europe,America and south Asia,supplying obsolete and hard-to-find components to meet their specific needs.

With the principle of “Quality Parts,Customers Priority,Honest Operation,and Considerate Service”,our business mainly focus on the distribution of electronic components. Line cards we deal with include Microchip,ALPS,ROHM,Xilinx,Pulse,ON,Everlight and Freescale. Main products comprise IC,Modules,Potentiometer,IC Socket,Relay,Connector.Our parts cover such applications as commercial,industrial, and automotives areas.

We are looking forward to setting up business relationship with you and hope to provide you with the best service and solution. Let us make a better world for our industry!



Contact us

Tel: +86-755-8981 8866 Fax: +86-755-8427 6832

Email & Skype: info@chipsmall.com Web: www.chipsmall.com

Address: A1208, Overseas Decoration Building, #122 Zhenhua RD., Futian, Shenzhen, China



Z23C-** Preconfigured Network Zone System



TABLE OF CONTENTS

Overview of Products	Page	3
Specs / Tools Needed	Page	4
Safety Information / Warnings	Page	5
Wall Mounting Bracket Installation	Page	6
Wall Mounting	Page	7
Removable Gland Plate	Page	7
Reversible Door	Page	8
Integrated Layout	Page	9
Recommended Installation Instructions for:		
Cage Removal	Page	10
Power Entry	Page	10
Uplink Entry	Page	10
Downlink Entry	Page	10
Patch Cord Routing	Page	11

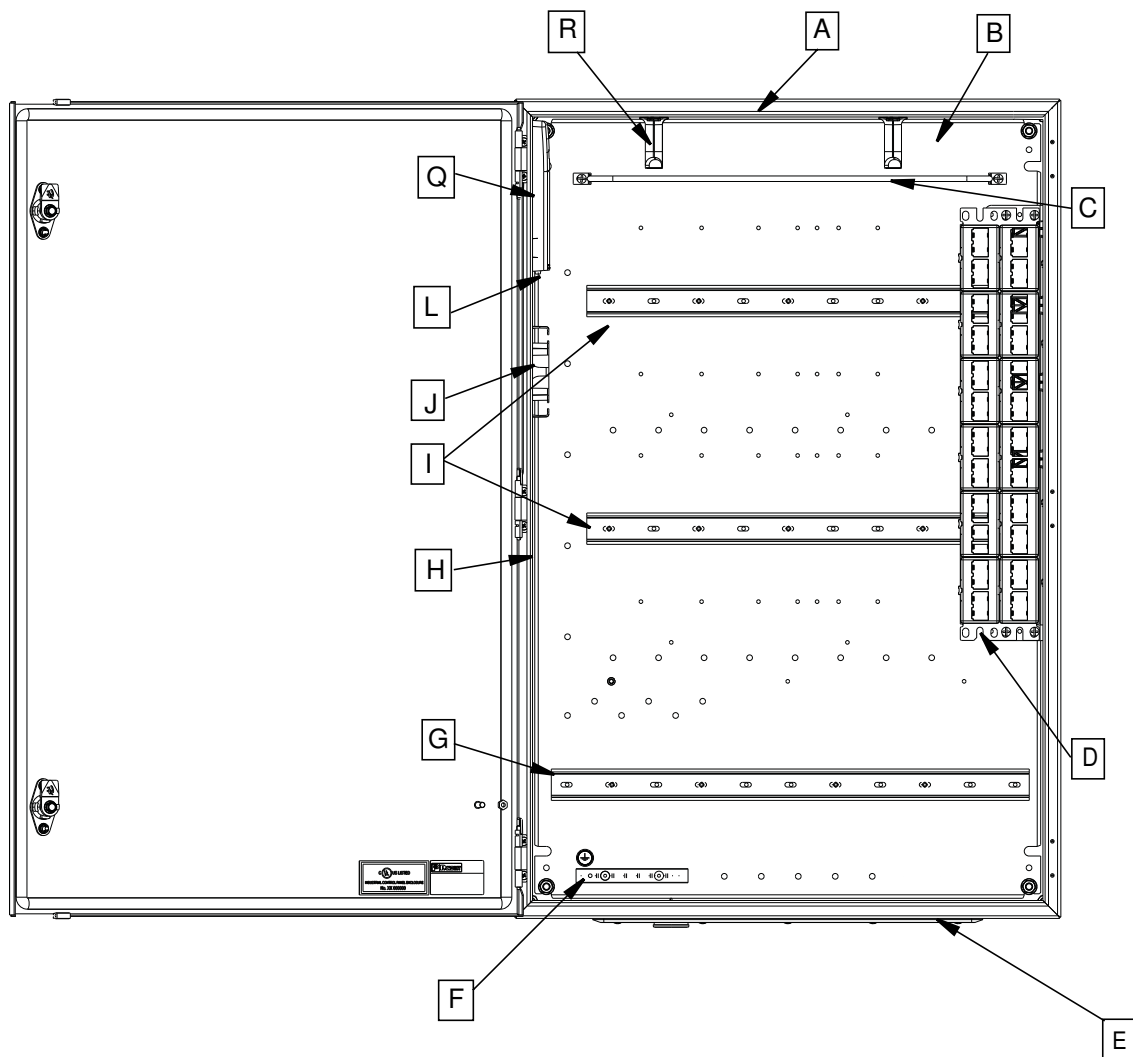

Preconfigured Network Zone System Z23C- configurations include the following:**

Pictured Above

- A). 24" x 36" Enclosure
- B). Preconfigured Back Panel
- C). Strain Relief Bar
- D). 48 Port Patch Panel
- E). Gland Plate
- F). Ground Bar
- G). 21.0" Din Rail
- H). Accessory Side Panels
- I). 17.75" Din Rail (2)
- J). Fiber Spool
- L). LC Fiber Optic Modules (6)
- Q). Fiber Surface Mount Box
- R). 700 mm L-rings

Not Pictured

- S). Hook and Loop Ties
- T). CAT6 Copper Patch Cords (16)
- U). CAT6 Mini-Com Modules (16)
- V). Cable Tie Push Mounts
- W). Cable Ties
- X). LC Fiber Patch Cords (4)
- Y). High Voltage Barrier

Preconfigured Network Zone Z23C-** Specifications			
Enclosure Rating	UL Type 4/12 and IP66 (IEC 60529), NEMA 4X available		
Installation	Wall mount with optional outside-mount flange		
Dimensions	Height	Width	Depth
	36.0" (914 mm)	24.0" (610 mm)	11.7" (297 mm)
Weight	90 lbs. (40.8 kg)		

Tools and supplies needed to complete install of Preconfigured Zone System (not included):

- Fiber-optic trunk cable: FSPD504 or similar
- LC Fiber-optic connectors: FLCDMCXAQY or similar
- Fiber-optic termination tools: OptiCam termination kit or similar
- Category 6 copper cable for downlinks: PUR6504BU-UY or similar
- Copper cable termination tools: wire cutters, EGJT tool
- Rigid conduit for power and copper downlink cables
- Tools to cut enclosure sidewalls: Greenlee punch or similar
- 5/16" bolts for wall mounting of steel enclosure
- #6 AWG Infrastructure ground cable: RGEJ660PF or similar
- 3/8" bolts for wall mounting of stainless steel enclosure
- 3/8" socket or box wrench ground bar

SAFETY INFORMATION

The information and instructions contained in this document are not intended to be utilized as a substitute for proper training and experience in the safe installation and operation of product. Prior to installation, it is the Buyer's responsibility to consult with the appropriate local Authority Having Jurisdiction (AHJ) for all applicable codes, permits, regulations and standards.

This product, including any equipment that may be installed inside, should only be installed and serviced by a licensed electrical contractor, or competent technician, that meets the following qualifications;

- Is thoroughly familiar with this product and the instructions for installation and operation
- Is trained (accredited) in industry-accepted safe operating practices and procedures regarding identification and mitigation of high- and low- voltage hazards and situations.
- Is trained to identify and install appropriately-sized Branch Circuit Disconnect(s) with appropriately-sized Branch-Circuit Protective Rating and Short-Circuit Current Rating (SCCR), before connecting Panduit product to the branch circuit.
- Is trained and authorized to energize, de-energize, clear and ground power distribution equipment.
- Is trained in the care and use of PPE (personal protective equipment) including, but not limited to; arc-flash protective clothing, safety glasses, face shield, hard hat, gloves, and non-conductive tools (clamp stick, hot stick, etc

WARNING

Be sure wall is capable of supporting cabinet and equipment.

DISCLAIMER OF WARRANTIES AND LIMITATION OF LIABILITIES

The practices contained herein are designed as a guide for use by persons having technical skill at their own discretion and risk. Panduit does not guarantee any favorable results or assume any liability in connection with these instructions. Local, State, Federal, and Industry Codes and Regulations, as well as manufacturers requirements, must be consulted before proceeding with any project. Panduit Corp. makes no representations of nor assumes any responsibility for the accuracy or completeness set forth herein. **Panduit disclaims any liability arising from any information contained herein or for the absence of same.**

Wall Mounting Bracket Installation

Note: The enclosure may be mounted to the wall without the mounting brackets

Step 1: Turn enclosure on its side with the locks orientated towards the top. Using Latch Tool, turn both locks towards each other to open door.

Step 2: Install Wall Mounting Brackets into back of the enclosure aligning threaded studs on brackets to holes located in back of the enclosure. Be sure obround mounting holes on the wall mounting bracket align outward.

Step 3: Secure wall mounting brackets using the supplied sealing washers use (1) per threaded stud.

Torque spec:

Steel Enclosure: 5/16" washers = 30 in-lbs

Stainless Steel Enclosure: 3/8" washers = 40 in-lbs

Step 4: Close Door. Using Latch Tool, turn both locks to secure the door.

If Mounting Flanges are not used:

For Steel Enclosure: Use 5/16" Sealing Washer (supplied) and a 5/16" Bolt (not supplied) in the locations where the threaded studs in the mounting flanges would go to mount enclosure directly to wall.

For Stainless Steel Enclosure: Use 3/8" Sealing Washer (supplied) and a 3/8" Bolt (not supplied) in the locations where the threaded studs in the mounting flanges would go to mount enclosure directly to wall.

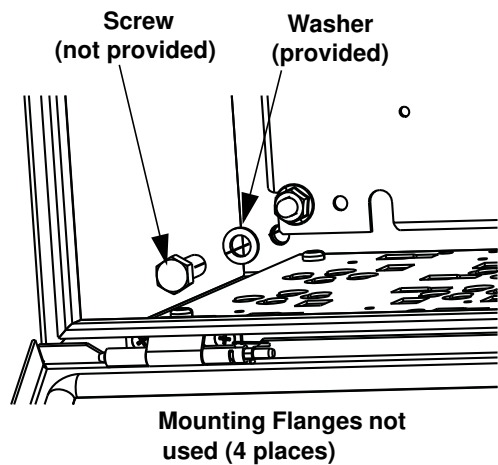
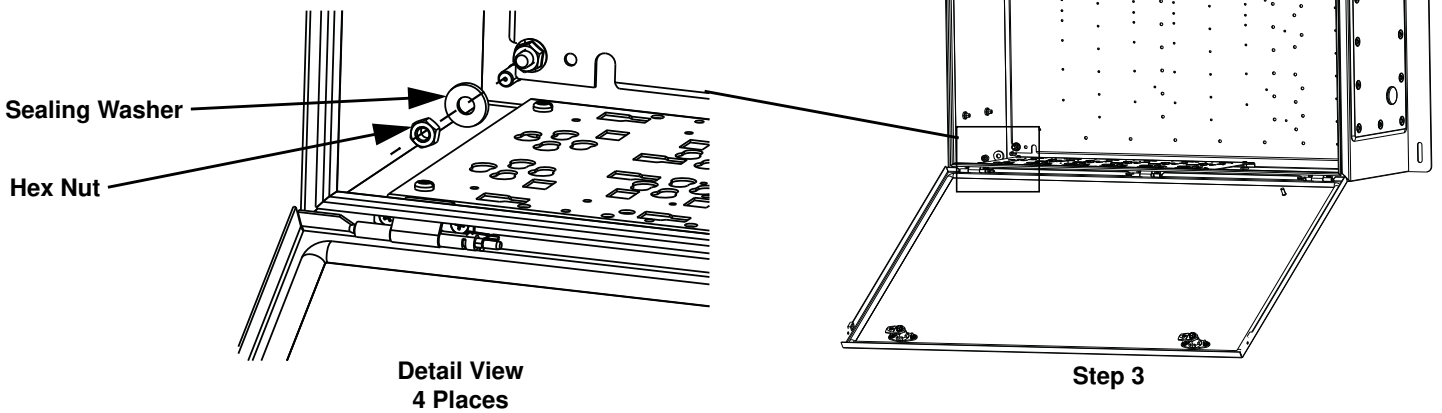
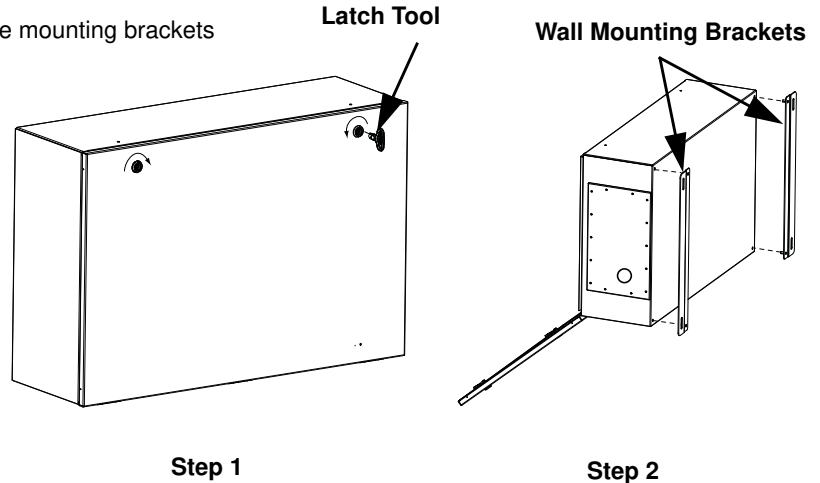

Wall Mounting

Enclosure may be mounted on any wall utilizing Unistrut or by drilling directly into any concrete wall. There are two mounting hole locations on the top flange and two locations at the bottom flange.

Step 1:

Drill holes 19.25"-22" apart horizontally and 38" apart vertically.

Step 2:

Mount the enclosure with the locks to the right and secure.

If mounting flanges are not used:

The holes in the wall will be 22.5" apart horizontally and 34.5" apart vertically.

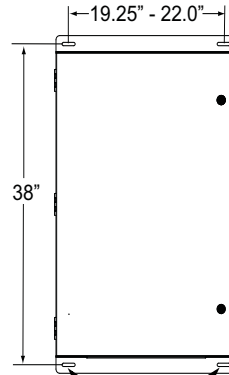

Hole Locations for Wall Mounting

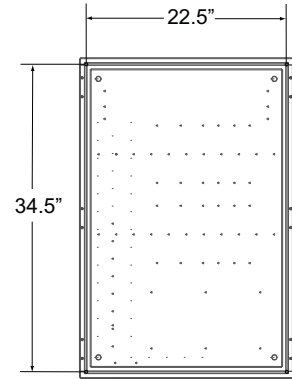

Dimensions for Wall Mounting without Flanges

Removable Gland Plate

Remove the gland plate prior to drilling holes for conduit entry. Accommodations for incoming conduit have been supplied on the enclosure. This will help prevent metal shavings from entering the electronic components in the enclosure. Recommend installation of IP66 rated conduit fittings that comply with the IEC codes that are applicable to the intended application. The Gland Plate, located on bottom of the enclosure, is removable for machining to accept bulkhead connectors or compression fittings. To remove gland plate, (12) screws and (12) flat washers attached to the threaded studs of the gland plate and remove plate from the enclosure. When reinstalling the gland plate, ensure the nuts are tightened until the gland plate flanges make contact with the enclosure surface.

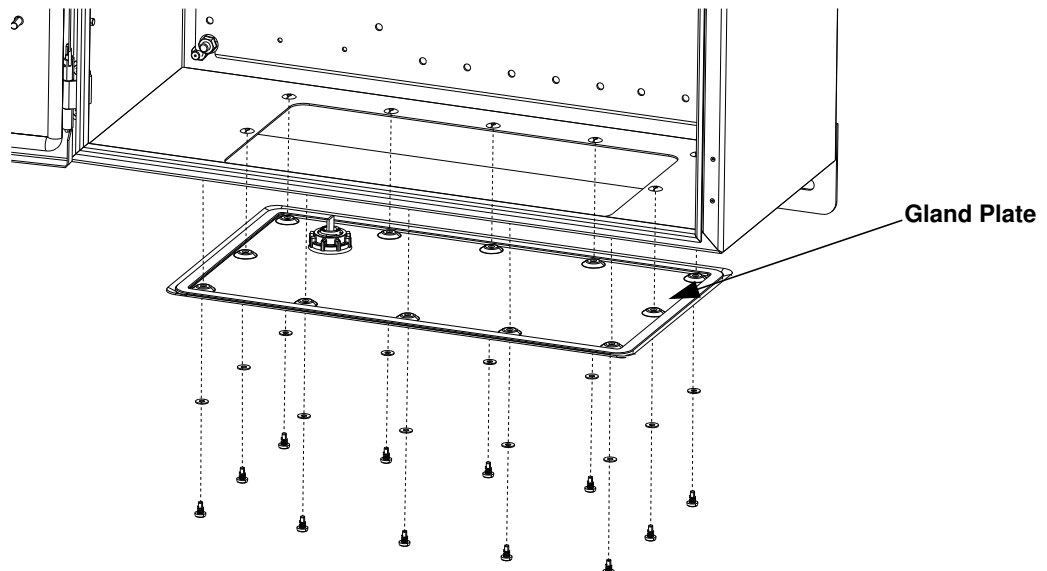

Reversible Door

The enclosure comes with the door opening to the left.
The door may be reversed to open to the right.

Step 1: Remove pins from the door hinges.

Step 2: Remove screws and door hinges

Step 3: New Hole locations will have to be drilled or punched out. Reinstall hinges and screws on opposite side.

Step 4: Turn door 180 degrees and mount to the opposite side of the enclosure. Insert the same pins to secure the door.

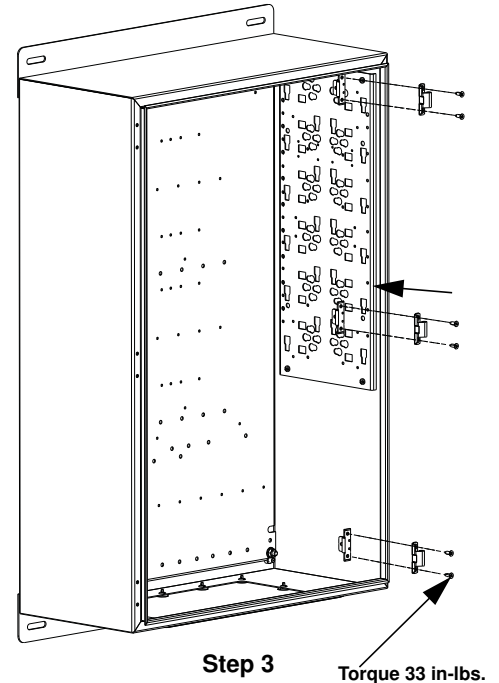
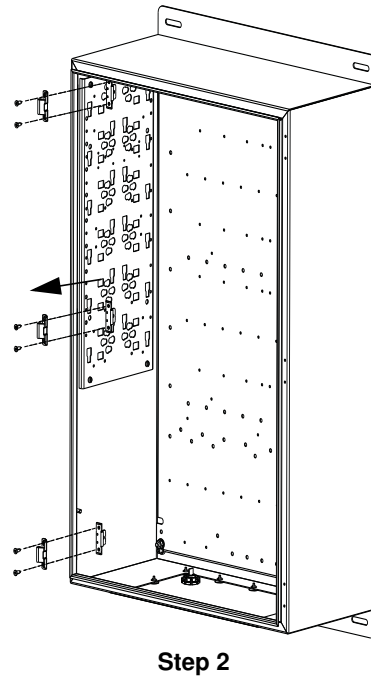
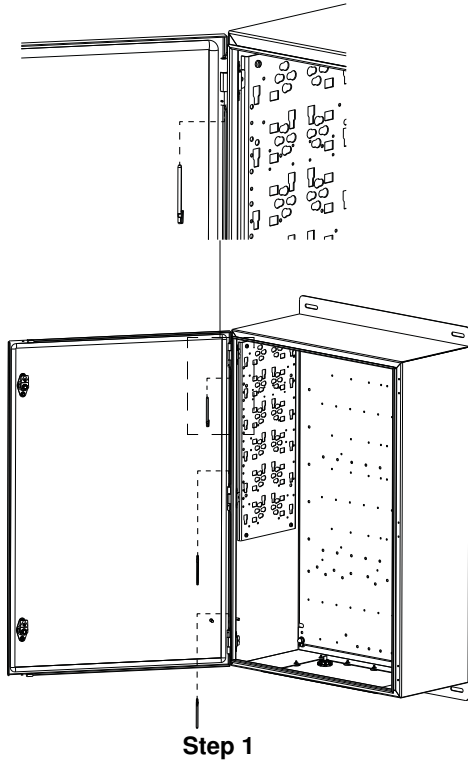

Add silicone to bolts
(6x)
(Not Supplied)

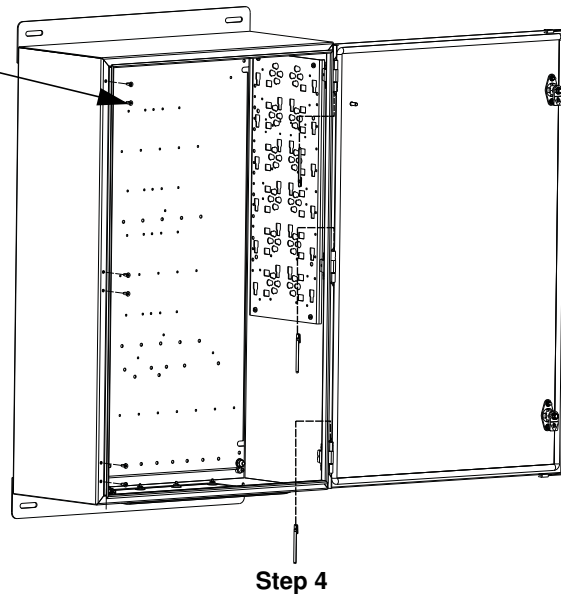

Proposed Integrated Layout

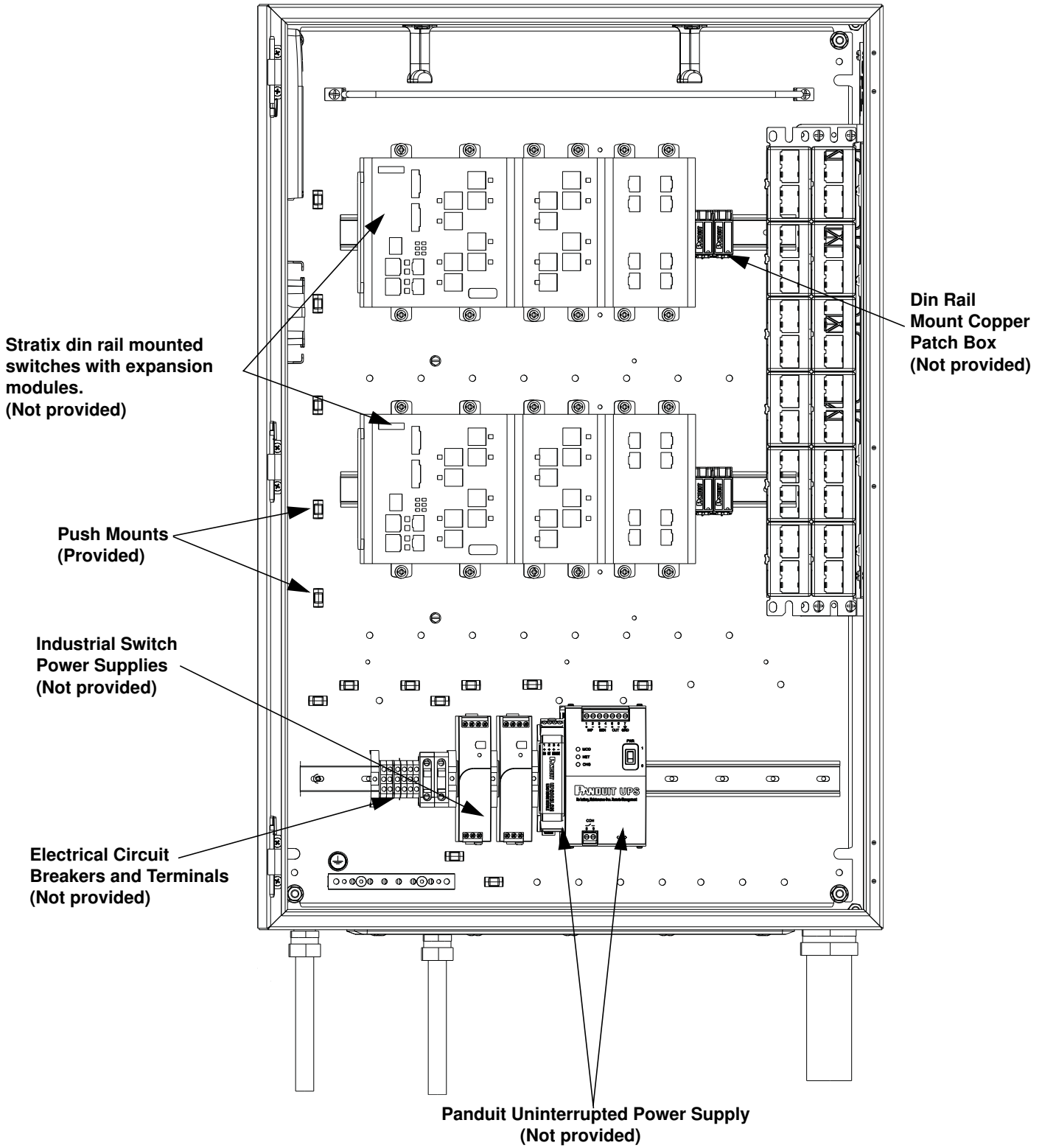

Cage Removal

Remove(3) #10-32 screws and washers

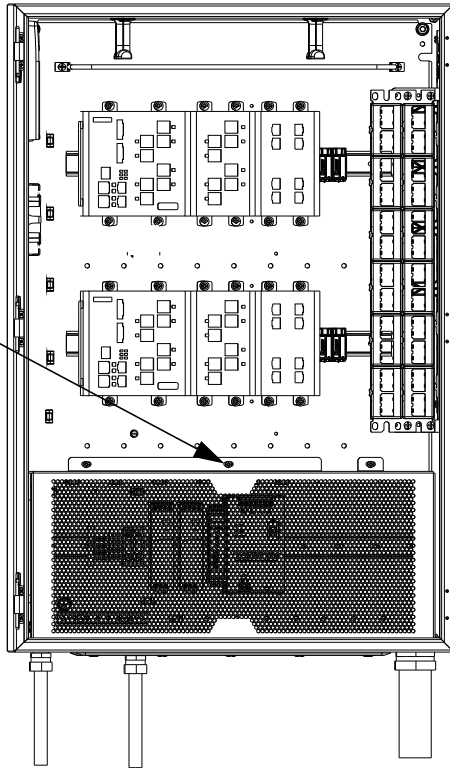

Recommended Installation Instructions for Power Entry

Remove plug in gland plate and replace with conduit fitting. Recommend installation of IP66 rated conduit fittings that comply with the IEC codes that are applicable to the intended application.

Connect Infrastructural ground to ground bar

Power Conduit Entry

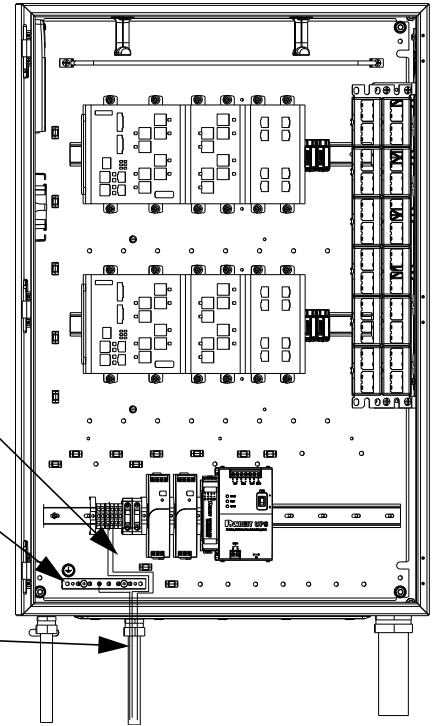

Recommended Installation Instructions for Uplink Entry

Uplink cable (fiber shown) spooled in the surface mount box

Uplink Cable Conduit Entry

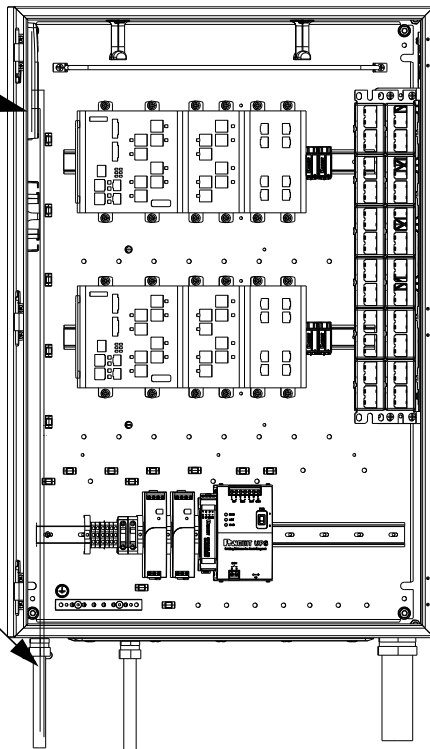

Recommended Installation Instructions for Downlink Entry

Service loop formed behind the patch panel or on top of the cable management L rings.

Downlink Cable Conduit Entry

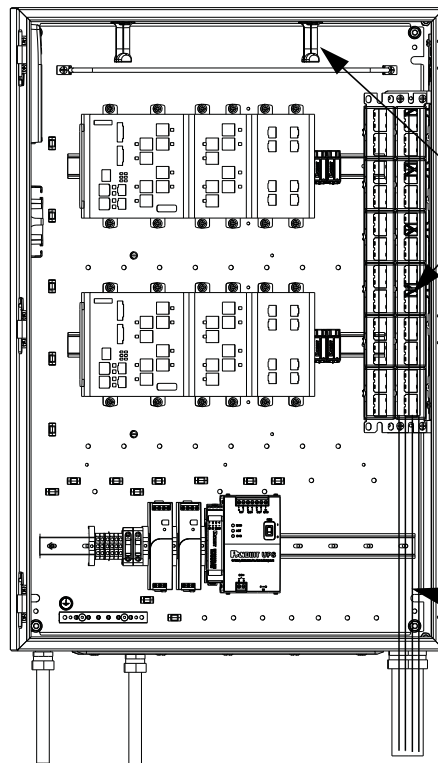

Recommended Installation Instructions for Patch Cord Routing

Patch cords supported by the strain relief bar and L-ring managers, routed from the switch to the patch panel (Switch not included) Secure with hook and loop that is provided

Route fiber cord from surface mount box to switch. Route fiber patch cord slack on the fiber spool in between box and switch.

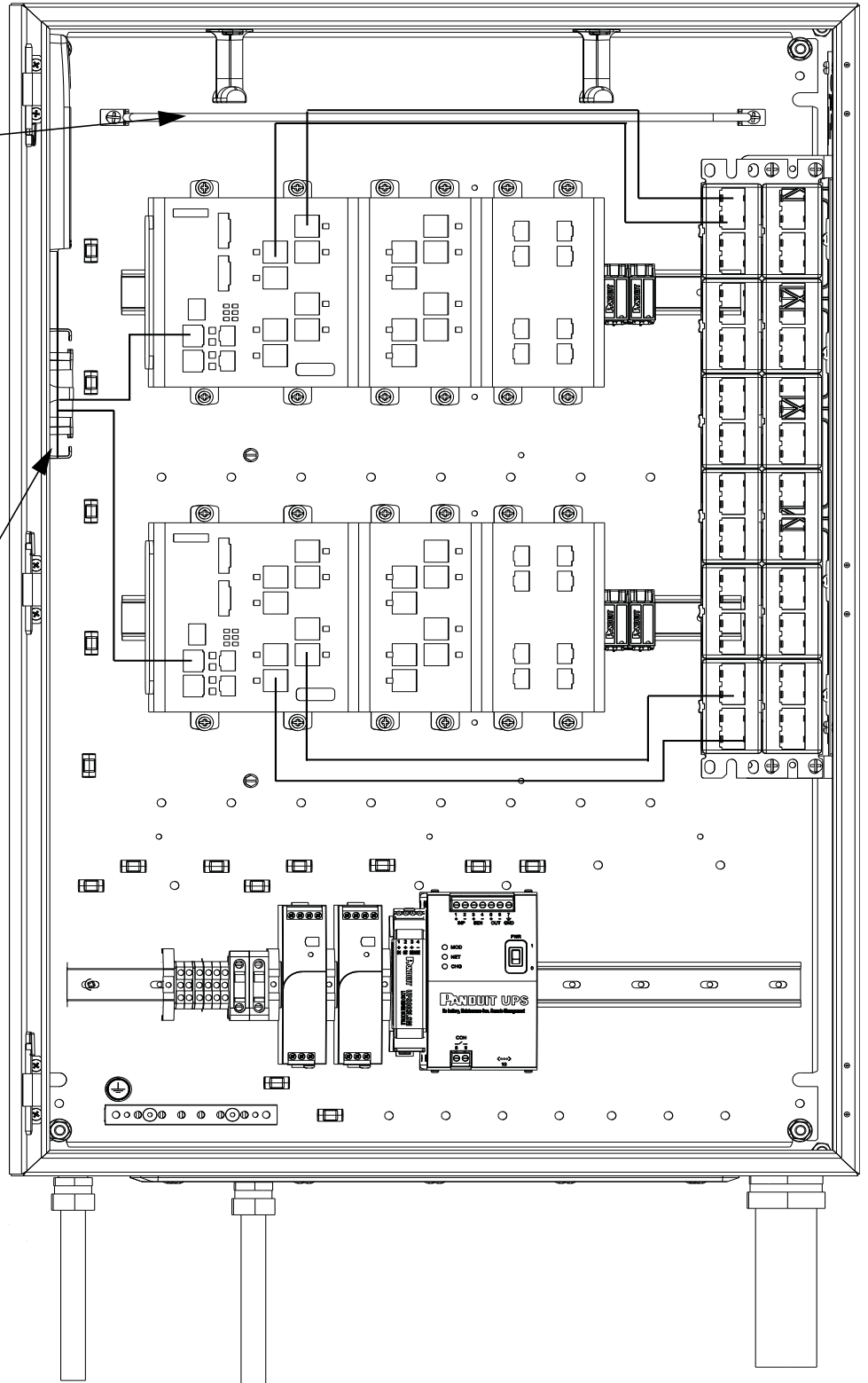

For Instructions in Local Languages
and Technical Support:

For Technical Support: http://www.panduit.com/wcs/Satellite?pagename=PG_Wrapper&friendlyurl=/en/support/contact-us

PANDUIT
www.panduit.com

E-mail:
tp-csdebt@panduit.com

Fax:
(800)777-3300