



Chipsmall Limited consists of a professional team with an average of over 10 year of expertise in the distribution of electronic components. Based in Hongkong, we have already established firm and mutual-benefit business relationships with customers from,Europe,America and south Asia,supplying obsolete and hard-to-find components to meet their specific needs.

With the principle of “Quality Parts,Customers Priority,Honest Operation,and Considerate Service”,our business mainly focus on the distribution of electronic components. Line cards we deal with include Microchip,ALPS,ROHM,Xilinx,Pulse,ON,Everlight and Freescale. Main products comprise IC,Modules,Potentiometer,IC Socket,Relay,Connector.Our parts cover such applications as commercial,industrial, and automotives areas.

We are looking forward to setting up business relationship with you and hope to provide you with the best service and solution. Let us make a better world for our industry!



Contact us

Tel: +86-755-8981 8866 Fax: +86-755-8427 6832

Email & Skype: info@chipsmall.com Web: www.chipsmall.com

Address: A1208, Overseas Decoration Building, #122 Zhenhua RD., Futian, Shenzhen, China



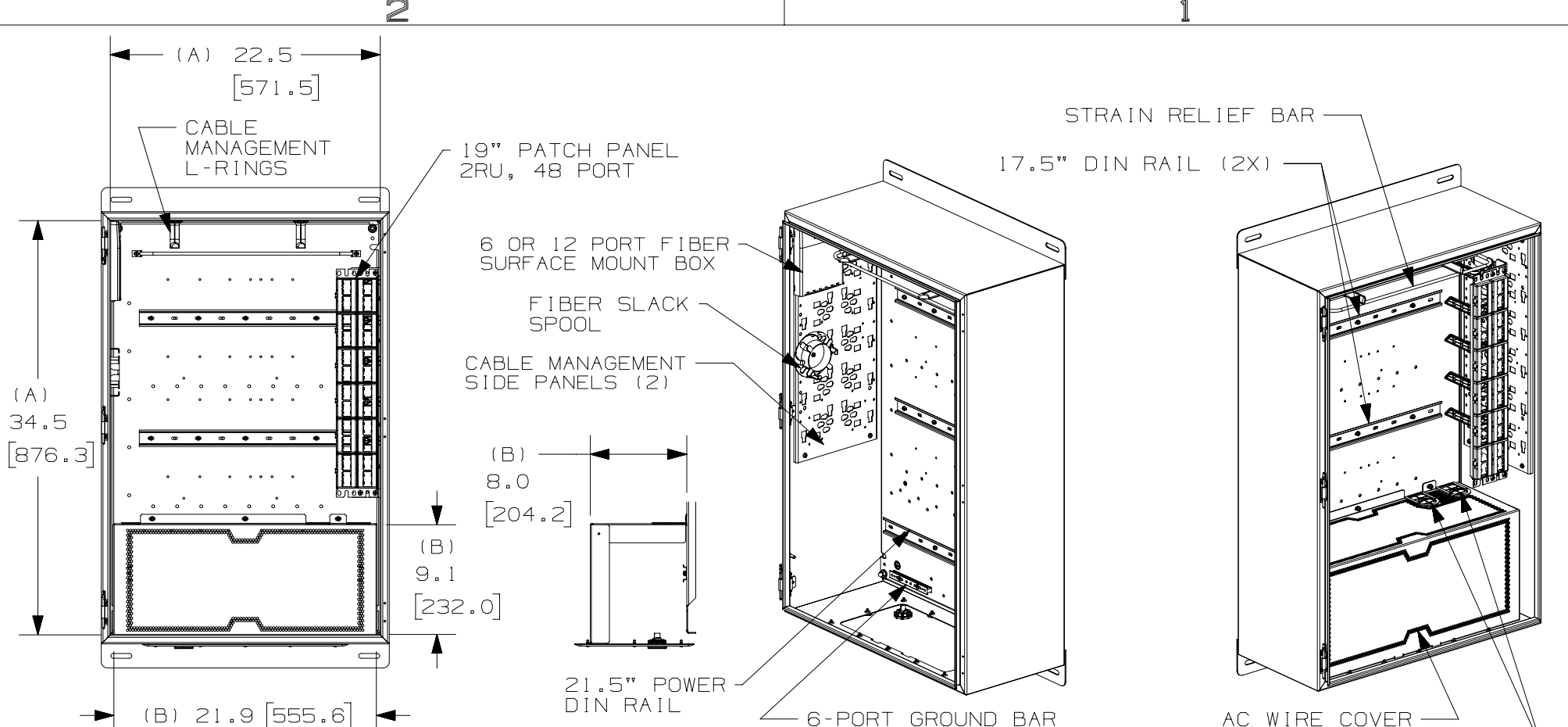

(A) DIRECT WALL MOUNT HOLE LOCATIONS
DOOR REMOVED FOR CLARITY

(B) DIMENSIONS UNDER THE AC WIRE COVER
AND OVER THE MOUNT PLATE

00A	3/15/16	NWW	MBVE	TIMH	REFER TO SHEET 1				
REV	DATE	BY	CHK	APR	DESCRIPTION				

TITLE		NETWORK ZONE SYSTEM, 24" X 36" ENCLOSURE CUSTOMER DRAWING		
ITEM REVISION NAME		15V510CQ/00		
DATASET FILE NAME		15V510CQ_DC/00A		
UNLESS OTHERWISE SPECIFIED, DIMENSIONAL TOLERANCES ARE: IN (mm)		MATERIAL:		
.x ± .1 [2.54] .xxx ± .005 [.127]		N/A		
.xx ± .01 [.25] ANGLES ± 5 °		DRAWING NUMBER:		
THIRD ANGLE PROJECTION		15V510CQ_DC		
DRAWN BY	DATE	CHK	SCALE	SIZE
NWW	3/15/16	MBVE	2:25	A
SHT 2 OF 2				