



Chipsmall Limited consists of a professional team with an average of over 10 year of expertise in the distribution of electronic components. Based in Hongkong, we have already established firm and mutual-benefit business relationships with customers from,Europe,America and south Asia,supplying obsolete and hard-to-find components to meet their specific needs.

With the principle of “Quality Parts,Customers Priority,Honest Operation,and Considerate Service”,our business mainly focus on the distribution of electronic components. Line cards we deal with include Microchip,ALPS,ROHM,Xilinx,Pulse,ON,Everlight and Freescale. Main products comprise IC,Modules,Potentiometer,IC Socket,Relay,Connector.Our parts cover such applications as commercial,industrial, and automotives areas.

We are looking forward to setting up business relationship with you and hope to provide you with the best service and solution. Let us make a better world for our industry!



Contact us

Tel: +86-755-8981 8866 Fax: +86-755-8427 6832

Email & Skype: info@chipsmall.com Web: www.chipsmall.com

Address: A1208, Overseas Decoration Building, #122 Zhenhua RD., Futian, Shenzhen, China



Customer Information Sheet

DRAWING No.: Z80-258 SHT 2 OF 2

IF IN DOUBT - ASK

©

NOT TO SCALE

THIRD ANGLE PROJECTION

ALL DIMENSIONS IN mm

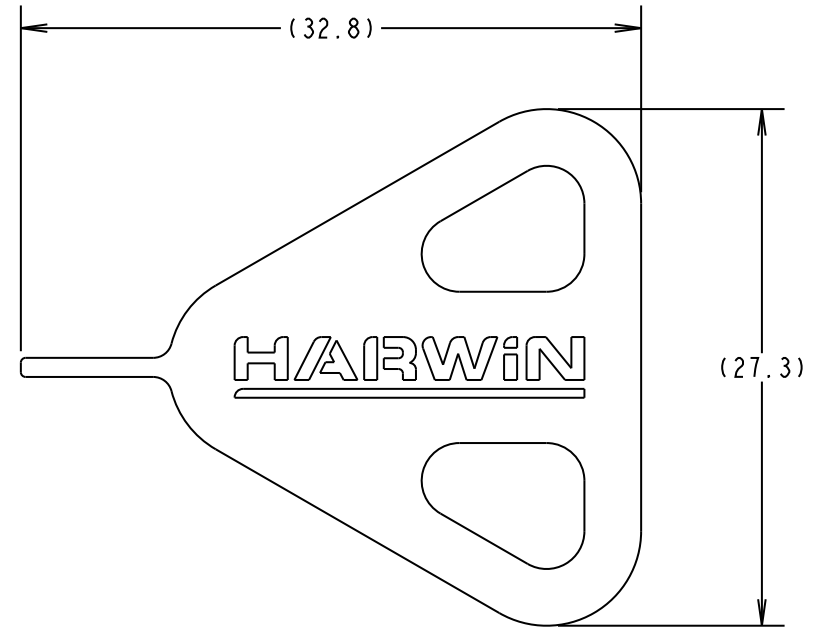
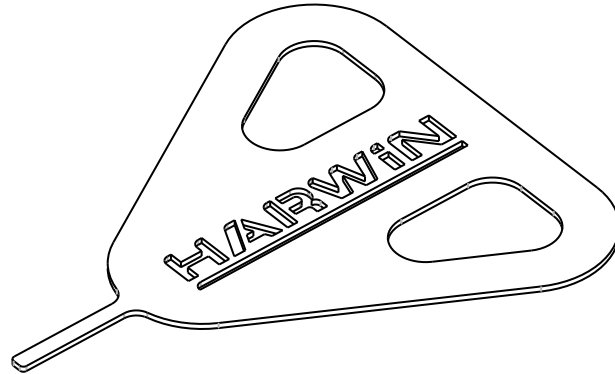

NOTES:

1) THIS EXTRACTION TOOL HAS BEEN DESIGNED FOR USE WITH FOLLOWING DATAMATE TRIO-TEK FEMALE SIGNAL CRIMP CONTACTS, HOUSING AND HOUSING ASSEMBLY:

- M80-25300XX = FEMALE CRIMP CONTACT FOR 24-22 AWG WIRE, SUPPLIED REELED
- M80-25400XX = FEMALE CRIMP CONTACT FOR 28-26 AWG WIRE, SUPPLIED REELED
- M80-28300XX = FEMALE CRIMP CONTACT FOR 24-22 AWG WIRE, SUPPLIED LOOSE
- M80-28400XX = FEMALE CRIMP CONTACT FOR 28-26 AWG WIRE, SUPPLIED LOOSE
- M80-454XX98 = FEMALE CRIMP HOUSING, NO JACKSCREWS
- M80-455XX98 = FEMALE CRIMP HOUSING, HEXAGONAL SLOTTED JACKSCREWS
- M80-456XX98 = FEMALE CRIMP HOUSING, HEXAGONAL SOCKET JACKSCREWS
- M80-457XX98 = FEMALE CRIMP HOUSING, REVERSE FIX JACKSCREWS
- M80-458XX98 = FEMALE CRIMP HOUSING, GUIDE PIN WITH PANEL MOUNT JACKSCREWS

2) THIS TOOL CAN BE USED TO AID THE ASSEMBLY OF CONTACTS INTO HOUSING.

3) FOR EXTRACTION TOOL INSTRUCTION SPECIFICATIONS, SEE INSTRUCTION SHEET IS-28, AVAILABLE AT <http://www.harwin.com/downloads/instructions/>

4) PACKING = BAG

BMK	2c	22.08.08	10130
NAME	ISS.	DATE	C/NOTE
APPROVED:		BMK	
CHECKED:		RA	
DRAWN:		B. M. KENT	
CUSTOMER REF.:			
ASSEMBLY DRG:			

HARWIN

THIS DRAWING AND ANY INFORMATION OR DESCRIPTIVE MATTER SET OUT HEREON ARE CONFIDENTIAL AND COPYRIGHT PROPERTY OF THE HARWIN GROUP AND MUST NOT BE DISCLOSED, LOANED, COPIED OR USED FOR MANUFACTURING, TENDERING OR FOR ANY OTHER PURPOSE WITHOUT THEIR WRITTEN PERMISSION.

TOLERANCES
 X. = ±1mm
 X.X = ±0.25mm
 X.XX = ±0.10mm
 X.XXX = ±0.01mm
 ANGLES = ±5°
 UNLESS STATED

MATERIAL:
 STAINLESS STEEL
FINISH:
S/AREA: mm²

TITLE: DATAMATE TRIO-TEK FEMALE CONTACT EXTRACTION TOOL

DRAWING NUMBER:
 Z80-258
 SHT 2 OF 2

HARWIN USA TEL: 603 893 5376 FAX: 603 893 5396 mis@harwin.com	HARWIN Europe (UK) TEL: 023 9231 4545 FAX: 023 9231 4590 mis@harwin.co.uk	HARWIN Asia TEL: +65 6 779 4909 FAX: +65 6 779 3868 mis@harwin.com.sg
---	---	---