



Chipsmall Limited consists of a professional team with an average of over 10 year of expertise in the distribution of electronic components. Based in Hongkong, we have already established firm and mutual-benefit business relationships with customers from,Europe,America and south Asia,supplying obsolete and hard-to-find components to meet their specific needs.

With the principle of “Quality Parts,Customers Priority,Honest Operation,and Considerate Service”,our business mainly focus on the distribution of electronic components. Line cards we deal with include Microchip,ALPS,ROHM,Xilinx,Pulse,ON,Everlight and Freescale. Main products comprise IC,Modules,Potentiometer,IC Socket,Relay,Connector.Our parts cover such applications as commercial,industrial, and automotives areas.

We are looking forward to setting up business relationship with you and hope to provide you with the best service and solution. Let us make a better world for our industry!



## Contact us

Tel: +86-755-8981 8866 Fax: +86-755-8427 6832

Email & Skype: info@chipsmall.com Web: www.chipsmall.com

Address: A1208, Overseas Decoration Building, #122 Zhenhua RD., Futian, Shenzhen, China





**Z8F16800128ZCOG**

**Z8 Encore! XP<sup>®</sup> F1680 28-Pin  
Series Development Kit**

**User Manual**

UM020305-0508

# Safeguards

The following precaution must be observed when working with the devices described in this document.



**Caution:** *Always use a grounding strap to prevent damage resulting from electrostatic discharge (ESD).*

# Revision History

Each instance in Revision History reflects a change to this document from its previous revision. For more details, refer to the corresponding pages and appropriate links in the table below.

Date	Revision Level	Description	Page No
May 2008	5	Added Z8F1680SJ020 to the <a href="#">Introduction</a> section.	1
March 2008	4	Modified <a href="#">Schematics</a> Table 2 to incorporate changes to R15 from 220 $\Omega$ to 0 $\Omega$ . Added Note 3 to the <a href="#">Schematics</a> .	11
February 2008	3	Updated document with new Zilog logo and text. Implemented Style Guide.	All
June 2007	2	Removed IrDA.	3, 7, 8, 9, 12
November 2006	1	Original issue.	All



# Table of Contents

<b>Introduction</b> .....	<b>1</b>
Features .....	3
CPU .....	5
<b>F1680 28-Pin Series Development Board</b> .....	<b>6</b>
Features .....	7
MCU .....	7
Power and Communication Interfaces .....	9
External Interface Headers JP1 and JP2 .....	9
<b>Installation</b> .....	<b>10</b>
<b>Schematics</b> .....	<b>11</b>
<b>Customer Support</b> .....	<b>14</b>

# Introduction

Zilog's Z8 Encore! XP<sup>®</sup> F1680 Series are Flash microcontrollers based on Zilog's eZ8<sup>™</sup> CPU, the 8-bit CPU core. Optimized for low-power applications, the Z8 Encore! XP F1680 Series support 1.8 V to 3.6 V operation with extremely low active, halt, and stop mode currents and an assortment of speed and low power options.

Z8F1680SJ020 is the silicon used in the board. For more details, refer to *Z8 Encore! XP<sup>®</sup> F1680 Series Product Specification (PS0250)* available for download at [www.zilog.com](http://www.zilog.com).

The features available to balance power and performance needs of applications include:

- Wide operating voltage range: 1.8 V to 3.6 V.
- Active, Halt, and Stop operational modes with the ability to enable or disable peripherals for power savings.
- Oscillator control that determines clock source, operating speed, and fail safe operation in addition to fast wakeup.
- A user-controlled Program RAM area to store interrupt service routines of high-frequency interrupts. The Program RAM mechanism ensures low average current and quick response for high frequency interrupts.

The Z8 Encore! XP F1680 Series support up to 24 KB Flash program memory and 2 KB register data RAM. It also supports up to 256 B Non-Volatile Data Storage (NVDS) besides the 1 KB of Program RAM.

The Z8 Encore! XP F1680 Series feature up to eight single-ended channels of 10-bit high speed analog-to-digital conversion with a sample and hold circuit. It also features one low-power operational amplifier for current sampling and two comparators. An on-chip temperature sensor

allows die temperature measurement over a range of  $-40\text{ }^{\circ}\text{C}$  to  $+105\text{ }^{\circ}\text{C}$ . These devices also include an on-chip low voltage detect block with user-selectable threshold.

Two full-duplex, 9-bit UARTs provide serial, asynchronous communication and support the local interconnect network (LIN) serial communications protocol. The LIN bus is a cost-efficient, single master, multiple slave organization that supports speed up to 20 kbps. The Z8 Encore! XP F1680 Series also support an Enhanced Serial Peripheral Interface (ESPI) controller that provides buffered full-duplex, synchronous, character-oriented channel, and a  $I^2C$  Master/Slave port to allow easy incorporation into any system.

The Z8 Encore! XP F1680 Series feature three 16-bit timers with Pulse-Width Modulation (PWM), Capture, and Compare capabilities. The timers can operate in Stop mode using a low-power 32 kHz peripheral clock. The noise filter prevents false MCU wakeup, which eventually results in long-lasting battery. The Z8 Encore! XP F1680 Series also feature a multichannel timer that supports four Capture/Compare modules on one timer.

The Z8 Encore! XP F1680 Series feature a user-selectable system clock and an external 32 kHz, watch-crystal-based, low-power peripheral clock. System clock sources include a high accuracy Internal Precision Oscillator (IPO) requiring no external components and an on-chip oscillator using external crystal, resonator, or low-cost RC circuit. The on-chip IPO is 2% accurate over standard temperature and voltage, and its output frequency is selectable in the 11 MHz to 43 kHz range. A low-power external 32 kHz, watch-crystal-based peripheral clock is available for the operation of timers in STOP mode as well as for the implementation of a real-time clock.

The Z8 Encore! XP F1680 Series support a single-pin debugger and programming interface that simplifies code development and allows easy in-circuit programming.

## Features

Key features of Z8 Encore! XP F1680 Series Flash microcontrollers include:

- 20 MHz eZ8™ CPU core
- 8 KB, 16 KB, or 24 KB Flash memory with in-circuit programming capability
- 1 KB or 2 KB register data RAM
- Up to 1 KB Program RAM for program code shadowing and data storage (optional)
- Up to 256 B Non-Volatile Data Storage (NVDS)
- Optional fast 8-channel, 10-bit Analog-to-Digital Converter (ADC)
- On-chip temperature sensor
- Up to two on-chip analog comparators (20-pin and 28-pin packages have only one)
- On-chip Low-Power Operational Amplifier (LPO)
- Two full-duplex, 9-bit, Universal Asynchronous Receiver/Transmitter (UART) ports with support of Local Interconnect Network (LIN) protocol (20-pin and 28-pin packages have only one)
- Enhanced Serial Peripheral Interface (SPI) controller (28-pin, 40-pin, and 44-pin packages only)
- I<sup>2</sup>C Master/Slave
- Three enhanced 16-bit timers with Capture, Compare, and PWM capability
- Optional multichannel timer that supports four capture/compare modules on one timer (44-pin packages only)
- Watchdog Timer (WDT) with dedicated internal RC oscillator



- 17 to 39 General-Purpose Input/Output (GPIO) pins depending on package
- Up to 8 direct LED drives
- Up to 20 vectored interrupts
- On-Chip Debugger (OCD)
- Power-On Reset (POR)
- Built-in Low-Voltage Detection (LVD) and Voltage Brownout (VBO) protection
- 32 kHz secondary oscillator for timers
- Internal Precision Oscillator (IPO) with output frequency in the range of 43.2 kHz to 11.059 MHz
- Crystal oscillator with three power settings and external RC network option
- Wide operation voltage: 1.8 V to 3.6 V
- Up to thirty-nine 5 V-tolerant inputs (digital mode only)
- Ultra low power consumption:
  - Active mode:
    - Typical < 0.2 mA/MHz @1.8 V (Flash/PRAM On)
    - Typical < 0.1 mA/MHz @1.8 V (Flash Off/PRAM On)
  - Halt mode:
    - Typical < 70  $\mu$ A/MHz @1.8 V
  - Stop mode:
    - Typical < 0.01  $\mu$ A @1.8 V (all peripherals disabled)
    - Typical < 1.0  $\mu$ A @1.8 V (WDT running)
- 20-pin, 28-pin, 40-pin, and 44-pin packages
- 0 °C to +70 °C (standard), –40 °C to +105 °C (extended) operating temperature ranges

For more information on Z8 Encore! XP F1680 Series, refer to *Z8 Encore! XP<sup>®</sup> F1680 Series Product Specification (PS0250)*, available for download at [www.zilog.com](http://www.zilog.com).

## CPU

Zilog's eZ8<sup>™</sup> CPU, latest 8-bit CPU meets the continuing demand for faster and more code-efficient microcontrollers. It executes a superset of the original Z8<sup>®</sup> instruction set. The eZ8 CPU features include:

- Direct register-to-register architecture allows each register to function as an accumulator, improving execution time and decreasing the required Program Memory
- Software stack allows greater depth in sub-routine calls and interrupts more than hardware stacks
- Compatible with existing Z8 code
- Expanded internal Register File allows access up to 4 KB
- New instructions improve execution efficiency for code developed using higher-level programming languages including C
- Pipelined instruction fetch and execution
- New instructions for improved performance including BIT, BSWAP, BTJ, CPC, LDC, LDCI, LEA, MULT, and SRL
- New instructions support 12-bit linear addressing of the register file
- Up to 10 MIPS operation
- C-Compiler friendly
- Two to nine clock cycles per instruction

For more details on eZ8 CPU, refer to *eZ8<sup>™</sup> CPU User Manual (UM0128)* available for download at [www.zilog.com](http://www.zilog.com).

# F1680 28-Pin Series Development Board

The Z8 Encore! XP F1680 28-Pin Series development board is a development and prototyping board for the Z8 Encore! XP F1680 Series MCU. The board provides customers with a tool to evaluate features of the Z8 Encore! XP F1680 Series MCU and to start developing an application before building the hardware.

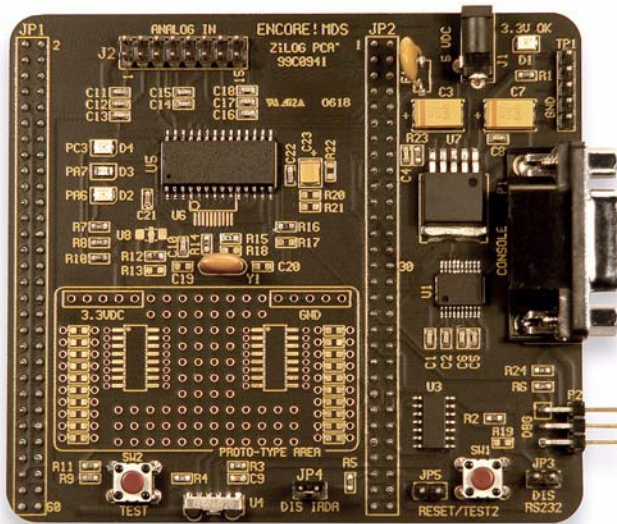

Figure 1. Z8 Encore! XP F1680 28-Pin Series Development Board

## Features

Key features of Z8 Encore! XP F1680 28-Pin Series development board include:

- Z8 Encore!<sup>®</sup> MCU (28-pin SOIC, Z8F1680SJ020SG)
- 3 LEDs
- RS-232 interface
- Two push buttons, RESET and TEST
- 5 V DC power connector
- On-Chip Debugger interface
- 20 MHz crystal (Y1)
- Header for ADC input
- Prototyping area
- External interface connectors JP1 and JP2
- 2.7 V to 3.6 V operating voltage with 5 V-tolerant inputs

## MCU

The Z8 Encore! XP F1680 28-Pin Series MCU is member of a family of Zilog<sup>®</sup> microcontroller products based upon the 8-bit eZ8<sup>™</sup> CPU. The Flash in-circuit programming capability allows for faster development time and program changes in the field. The eZ8 CPU is upward compatible with existing Z8<sup>®</sup> instructions. The rich peripheral set of the Z8 Encore! XP F1680 28-Pin Series makes it suitable for various applications including motor control, security systems, home appliances, personal electronic devices, and sensors.

The development board contains circuitry to support and present all the features of the Z8 Encore! XP F1680 28-Pin Series.

The key features of the Z8 Encore! XP F1680 28-Pin Series include:

- eZ8<sup>™</sup> CPU
- 16 K of Flash memory with in-circuit programming capability
- 2 KB of data RAM
- 1 KB of Program RAM
- 256 Bytes of NVDS
- One I<sup>2</sup>C
- One enhanced SPI controller
- Twenty-three I/O lines
- Nineteen interrupts
- Three 16-bit timers with capture, compare, and PWM capability
- Eight-channel, 10-bit Analog-to-Digital Converter (ADC)
- One full-duplex UART
- One comparator
- One temperature sensor
- Watchdog Timer (WDT) with internal RC oscillator
- Nineteen (28-pin package) I/O pins
- Programmable priority interrupts
- On-Chip Debugger
- Voltage Brownout (VBO) Protection
- Power-On Reset (POR)

- 2.7 V to 3.6 V operating voltage with 5 V-tolerant inputs
- Operating temperatures: 20° ±10° C

For more information on the Z8 Encore! XP<sup>®</sup> family of devices, refer to *Z8 Encore! XP<sup>®</sup> F1680 Series Product Specification (PS0250)*, available for download at [www.zilog.com](http://www.zilog.com).

## Power and Communication Interfaces

Table 1 provides jumper information concerning the shunt status, functions, devices and defaults affected by jumpers JP3 and JP4.

**Table 1. Jumpers JP3 and JP4**

Jumper	Status	Device Affected	Status	Default
JP3*	OUT	RS-232 interface	Enabled	X
JP3	IN	RS-232 interface	Disabled	
JP5	OUT	U5 RESET/ PD0	PD0 (GPIO)	X
JP5	IN	U5 RESET/ PD0	RESET when SW1 pressed	
<b>Note:</b> * These jumpers must not be OUT at the same time.				

## External Interface Headers JP1 and JP2

External interface headers JP1 and JP2 are shown in the schematic on page 13.

# Installation

Follow the instructions provided in *Z8 Encore! XP<sup>®</sup>/Z8 Encore!<sup>®</sup> (F0822, F082A, F1680, and F083A Series) Development Kits Quick Start Guide (QS0043)* for the software installation and setup of the Z8 Encore! XP F1680 28-Pin Series Development Kit.

# Schematics

This section includes schematics for the Z8 Encore! XP F1680 Series Development Board.

The following components appear in the schematic but are not installed on the board itself:

- C9
- JP4
- R3 through R5
- U4



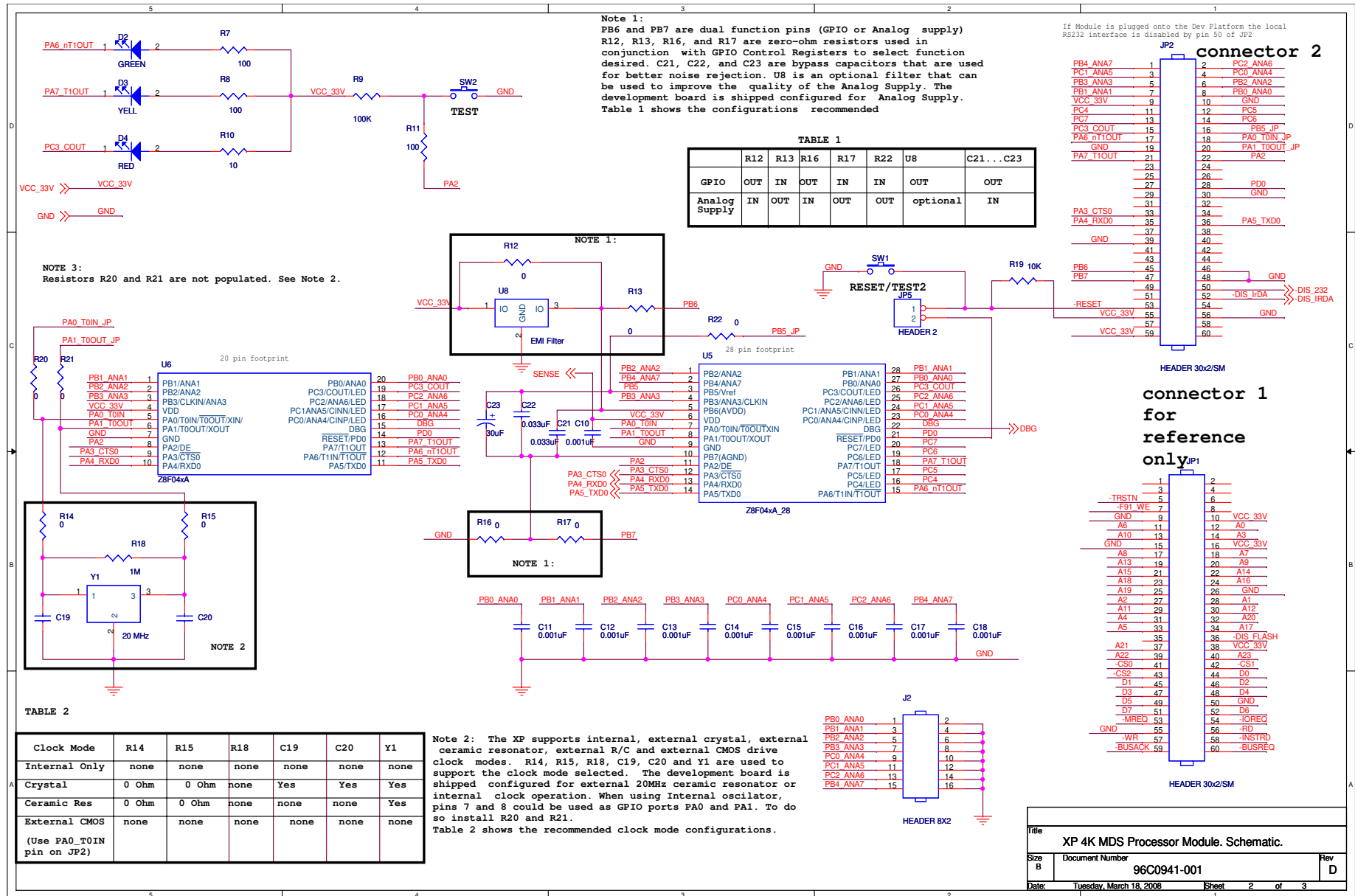
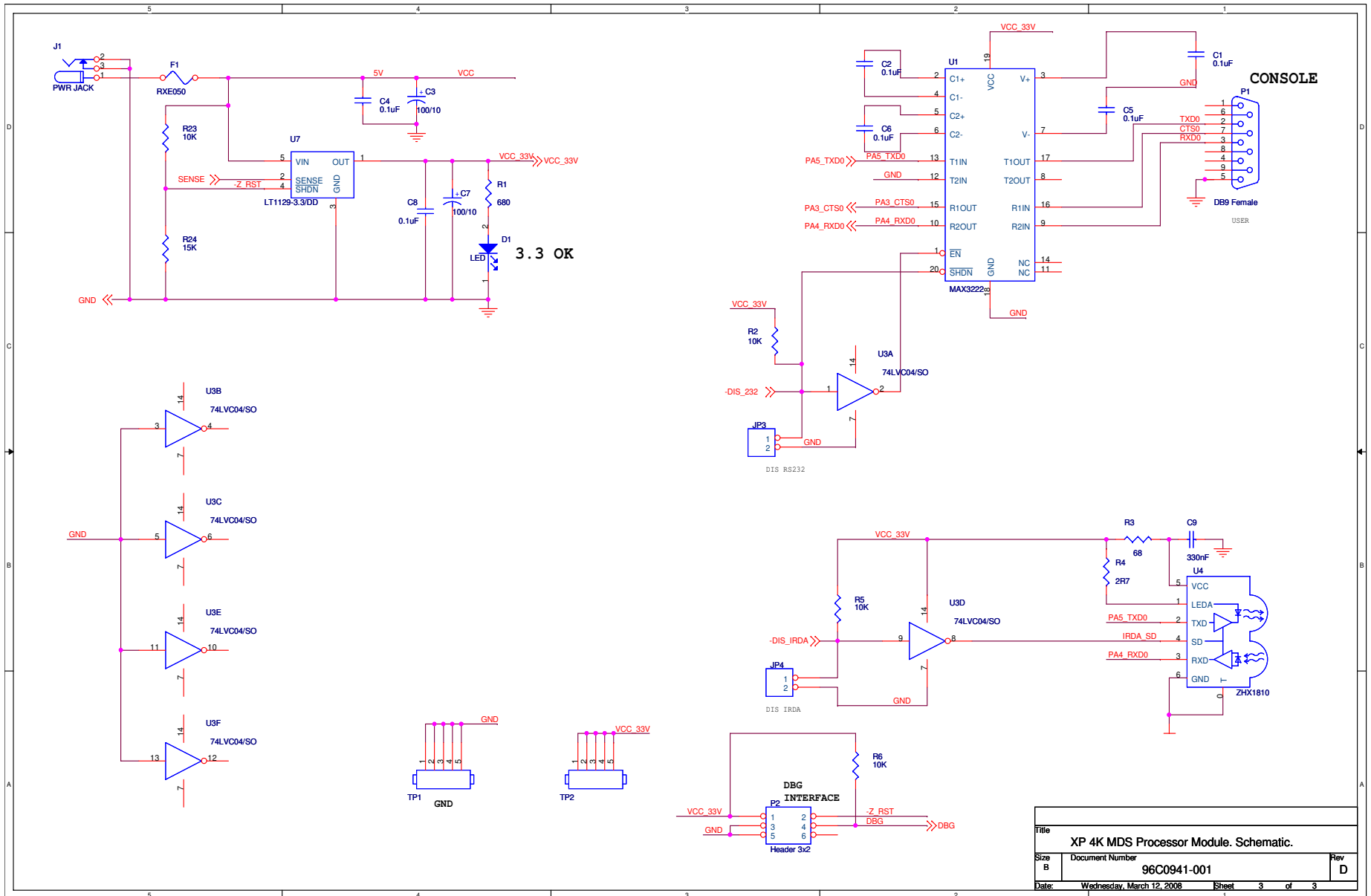

Figure 2. Z8 Encore! XP F1680 28-Pin Series MCU Development Board, Page 1 of 2





# Customer Support

For answers to technical questions about the product, documentation, or any other issues with Zilog's offerings, please visit Zilog's Knowledge Base at <http://www.zilog.com/kb>.

For any comments, detail technical questions, or reporting problems, please visit Zilog's Technical Support at <http://support.zilog.com>.



**Warning:** DO NOT USE IN LIFE SUPPORT

### **LIFE SUPPORT POLICY**

ZILOG'S PRODUCTS ARE NOT AUTHORIZED FOR USE AS CRITICAL COMPONENTS IN LIFE SUPPORT DEVICES OR SYSTEMS WITHOUT THE EXPRESS PRIOR WRITTEN APPROVAL OF THE PRESIDENT AND GENERAL COUNSEL OF ZILOG CORPORATION.

### **As used herein**

Life support devices or systems are devices which (a) are intended for surgical implant into the body, or (b) support or sustain life and whose failure to perform when properly used in accordance with instructions for use provided in the labeling can be reasonably expected to result in a significant injury to the user. A critical component is any component in a life support device or system whose failure to perform can be reasonably expected to cause the failure of the life support device or system or to affect its safety or effectiveness.

### **Document Disclaimer**

©2008 by Zilog, Inc. All rights reserved. Information in this publication concerning the devices, applications, or technology described is intended to suggest possible uses and may be superseded. ZILOG, INC. DOES NOT ASSUME LIABILITY FOR OR PROVIDE A REPRESENTATION OF ACCURACY OF THE INFORMATION, DEVICES, OR TECHNOLOGY DESCRIBED IN THIS DOCUMENT. ZILOG ALSO DOES NOT ASSUME LIABILITY FOR INTELLECTUAL PROPERTY INFRINGEMENT RELATED IN ANY MANNER TO USE OF INFORMATION, DEVICES, OR TECHNOLOGY DESCRIBED HEREIN OR OTHERWISE. The information contained within this document has been verified according to the general principles of electrical and mechanical engineering.

Z8, Z8 Encore!, and Z8 Encore! XP are registered trademarks of Zilog, Inc. eZ8 is a trademark of Zilog, Inc. All other product or service names are the property of their respective owners.