



Chipsmall Limited consists of a professional team with an average of over 10 year of expertise in the distribution of electronic components. Based in Hongkong, we have already established firm and mutual-benefit business relationships with customers from,Europe,America and south Asia,supplying obsolete and hard-to-find components to meet their specific needs.

With the principle of “Quality Parts,Customers Priority,Honest Operation,and Considerate Service”,our business mainly focus on the distribution of electronic components. Line cards we deal with include Microchip,ALPS,ROHM,Xilinx,Pulse,ON,Everlight and Freescale. Main products comprise IC,Modules,Potentiometer,IC Socket,Relay,Connector.Our parts cover such applications as commercial,industrial, and automotives areas.

We are looking forward to setting up business relationship with you and hope to provide you with the best service and solution. Let us make a better world for our industry!



## Contact us

Tel: +86-755-8981 8866 Fax: +86-755-8427 6832

Email & Skype: info@chipsmall.com Web: www.chipsmall.com

Address: A1208, Overseas Decoration Building, #122 Zhenhua RD., Futian, Shenzhen, China







## Introduction

Zilog's ZAURA RF Wireless Module is a cost-effective high-performance radio system on a module designed for the wireless transmission of digital information. It is available in both the 868MHz and 915MHz radio frequency bands.

The Module can be easily mounted on a two-layer PCB with minimal external connections. It is a small-footprint (1.61" by 1.02") wireless modular system that can be designed into any number of monitoring and control applications to enable wireless control. This Product User Guide document discusses its specifications, lists schematics and software commands, and provides a procedure for quickly getting started with development.

The Module, shown in Figure 1 mounted on a ZAURA RF Wireless Development Board with its protective shield removed, delivers raw data at a rate of 50kbits per second.

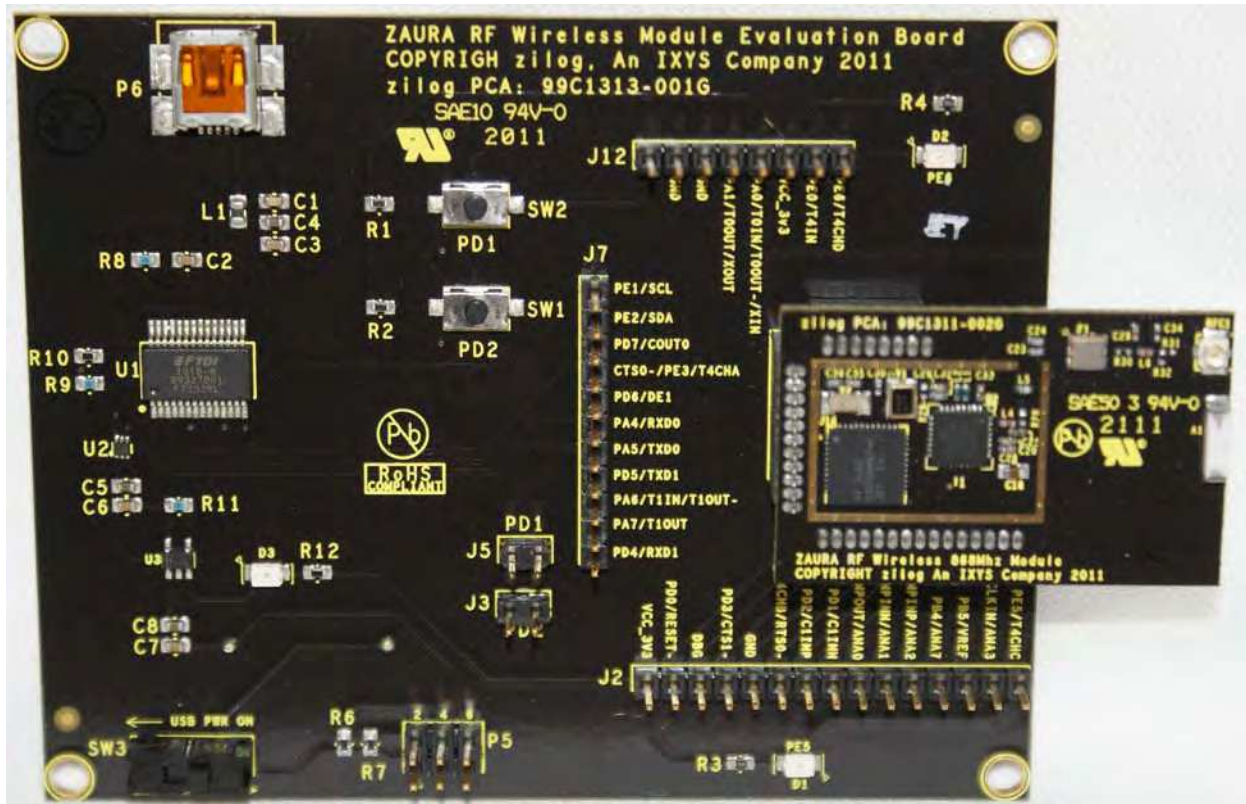

Figure 1. ZAURA RF Wireless Module and Development Board, shown without shield

## Module Features

The ZAURA RF Wireless Modules are shipped preloaded with a demo program which includes a command line interpreter for control of the ZAURA RF Wireless Modules via the UART. For details, see the ZAURA RF Wireless Module Shell User Manual (UM0235).

The ZAURA RF Wireless Module features many interface options, including:

- 2 four-wire UART ports (UART 0 is used by the ZAURA RF Shell Library if included in the project)
- I<sup>2</sup>C Controller
- 27 general-purpose port pins (21 available when using the ZAURA RF Shell Library, 25 available when the ZAURA RF Shell Library is not used)
- 8-channel 10-bit ADC

Top- and side-view dimensions of the Module are shown in Figures 2 and 3.

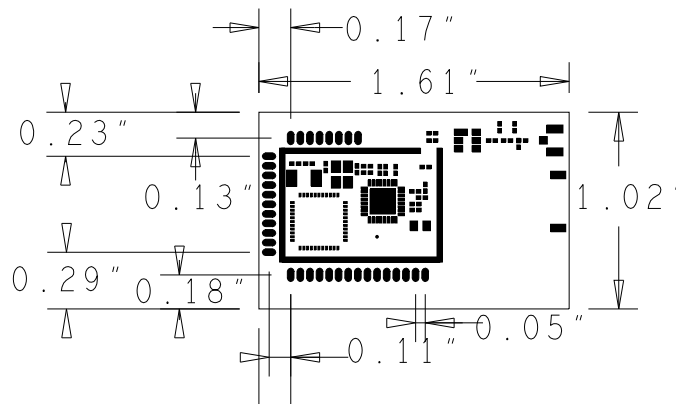

Figure 2. ZAURA RF Wireless Module Dimensions, Top View

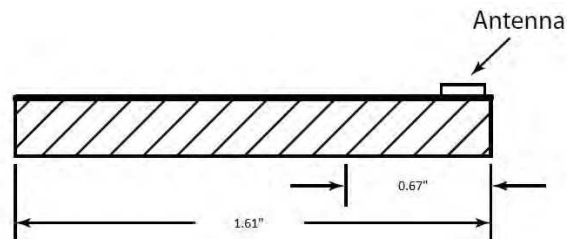

Figure 3. ZAURA RF Wireless Module Dimensions, Side View

► **Note:** Figures 2 and 3 refer to the 868MHz Module but are identical for the 915MHz Module.



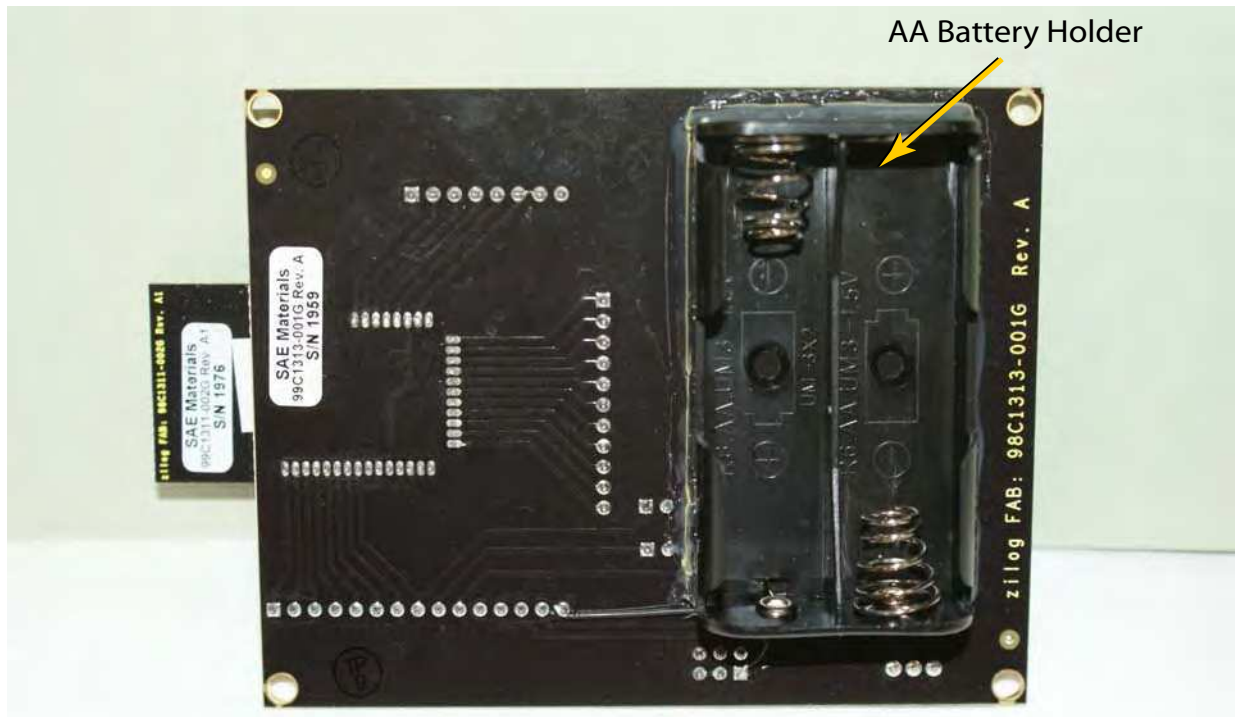

Figure 5. ZAURA RF Wireless Module and Development Board, Bottom View

Lastly, the ZAURA RF Wireless 868MHz Module is controlled by Zilog's Z8F2480 MCU, which is based on the Z8 Encore! XP® CPU architecture. The Module's RF transceiver is the Semtech SX1211, for which a full data sheet can be found at [www.semtech.com](http://www.semtech.com). For further details about the Z8F2480 MCU, please refer to the [Z8 Encore! XP F1680 Series Product Specification \(PS0250\)](#) on [www.zilog.com](http://www.zilog.com).

## Kit Contents

Each ZAURA RF Wireless Module Development Kit contains the following items:

- Two (2) ZAURA RF Wireless Modules
- Two (2) ZAURA RF Wireless Development Boards
- Two (2) USB Mini-B to Type A cables
- Four (4) AA batteries

All documentation and files can be downloaded from the [Zilog website](#).

## Module Pin Description

Table 1 describes the functions of each of the ZAURA RF Wireless Module's 41 pins.

**Table 1. ZAURA RF Wireless Module Pin-Out**

Pin #	Pin Name	Digital/ Analog	Details	I/O
1	PE6/T4CHD	D	Port Pin E6 or Timer 4 Channel D.	I/O
2	PE0/T4 <sub>IN</sub>	D	Port Pin E0 or Timer 4 In.	I
3	V <sub>CC</sub> _3.3V	A	Power, 3.3V.	
4	PA0/T0 <sub>IN</sub> /T0 <sub>OUT</sub> /X <sub>IN</sub>	D	Port Pin A0 or X <sub>IN</sub> can be used to connect external crystal Up to 20MHz.	I/O
5	PA1/T0 <sub>OUT</sub> /X <sub>OUT</sub>	D	Port Pin A1 or X <sub>OUT</sub> can be used to connect external crystal, up to 20MHz.	I/O
6	GND	A	Power, GND.	
7	GND	A	Power, GND.	
8	NC			
9	PE1/SCL	D	Port Pin E1 or I <sup>2</sup> C Clock.	I/O
10	PE2/SDA	D	Port Pin E2 or I <sup>2</sup> C Data.	I/O
11	PD7/C <sub>OUT</sub> 0	D	Port Pin D7 or Comparator out.	I/O
12	PE3/T4CHA/CTS0-	D	Port Pin E3 or Timer 4 Channel A or CTS0-.	I/O
13	PD6/DE1	D	Port Pin D6 or Driver Enable 1.	I/O
14	PA4/RXD0	D	Port Pin A4 or UART0 RXD0.	I/O
15	PA5/TXD0	D	Port Pin A5 or UART0 TXD0.	I/O
16	PD5/TXD1	D	Port Pin D5 or UART1 TXD1.	I/O
17	PA6/T1 <sub>IN</sub> /T1 <sub>OUT</sub> -	D	Port Pin A6 or Timer 1 In/Out.	I/O
18	PA7/T1 <sub>OUT</sub>	D	Port Pin A7 or Timer 1 Out.	I/O
19	PD4/RXD1	D	Port Pin D4 or UART1 RXD1.	I/O
20	V <sub>CC</sub> _3.3V	A	Power, 3.3V.	
21	PD0/RESET-	D	Port Pin D0 or Reset; input.	I/O
22	DBG	D	Debug input; connection for Zilog Debug Interface.	I/O
23	PD3/CTS1-	D	Port Pin D3 or UART1 CTS1-.	I/O
24	GND	A	Power, GND.	
25	PE4/T4CHB/RTS0-	D	Port Pin E4 or Timer 4 Channel D.	I/O
26	PD2/C1INP	D/A	Port Pin D2 or Comparator in P.	I/O
27	PD1/C1INN	D	Port Pin D1 or Comparator in N.	I/O
28	PB0/AMPOUT/ANA0	D	Port Pin B0.	I/O
29	PB1/AMPINN/ANA1	D/A	Port Pin B1 or Amp In N or Analog 1.	I/O
30	PB2/AMPINP/ANA2	D/A	Port Pin B2 or Amp In P or Analog 2.	I/O

**Table 1. ZAURA RF Wireless Module Pin-Out (Continued)**

<b>Pin #</b>	<b>Pin Name</b>	<b>Digital/ Analog</b>	<b>Details</b>	<b>I/O</b>
31	PB4/ANA7	D/A	Port Pin B4 or Analog in 7.	I/O
32	PB5/V <sub>REF</sub>	D/A	Port Pin B5 or External Reference Voltage for ADC; not to exceed V <sub>CC</sub> .	I/O
33	PB3/CLK <sub>IN</sub> /ANA3	D/A	Port Pin B3 or Clock Input or Analog 3.	I/O
34	PE5/T4CHC	D	Port Pin E5 or Timer input.	I/O



## Module Specifications

The ZAURA RF Wireless Module operates within the frequency, current, voltage and temperature specifications listed in Table 2.

**Table 2. ZAURA RF Wireless Module Specifications**

Frequency band:	868MHz (range: 863–870 MHz)
Channel	Center Frequencies (MHz)
0	865.6
1	866.2
2	866.8
3	867.4
Frequency band:	915MHz (range: 902–928 MHz)
Channel	Center Frequencies (MHz)
0	903.0
1	904.0
2	905.0
3	906.0
4	907.0
5	908.0
6	909.0
7	910.0
8	911.0
9	912.0
10	913.0
11	914.0
12	915.0
13	916.0
14	917.0
15	918.0
16	919.0
17	920.0
18	921.0
19	922.0
20	923.0
21	924.0
22	925.0
23	926.0
24	927.0
Receive current:	6mA @ 11MHz and 3V
Transmit current:	30mA @ 11MHz and 3V
Supply voltage:	2.1V–3.6V
Operating temperature range:	0°C–70°C



---

The ZAURA RF Wireless Modules Development Kits ship with Zilog's ad-hoc peer-to-peer software loaded into the Z8F2480 microcontroller's Flash memory. An example project, also included, allows users to investigate custom options. When combined with the Zilog Developer Studio Integrated Development Environment (ZDSII IDE) and debug tools, available from Zilog, developers can make changes to user source code which is included with the software project.

## Software Operation

Developing with the ZAURA RF Wireless Modules requires a PC running a serial terminal program; for purposes of demonstration, HyperTerminal is discussed in this document. To get started, observe the following brief procedure.

1. Install two AA batteries on the reverse side of the development board and slide switch SW3 to the BAT PWR ON position. Alternatively, when used with the USB interface, power can be supplied from the USB port if SW3 is set to the USB PWR ON position.
2. Connect a USB Mini-B to Type A cable between the ZAURA RF Wireless Module and a PC running Microsoft Windows (Zilog recommends Windows 7). The PC will begin to enumerate the USB device and should automatically download the appropriate PC software from the Internet. This software allows the ZAURA RF Wireless Module's USB interface to be used as a virtual COM (serial) port on the PC. After this software has been installed, note the port number of the new (virtual) COM port that has been added to the system.
3. To send commands to the Module, configure HyperTerminal for 57,600 bits per second, 8 data bits, no parity, 1 stop bit and hardware flow control. It is necessary to configure HyperTerminal to use the virtual COM port added to the system in the previous step. By default, the ZAURA RF Shell Library does not echo typed characters back to the console. To see typed characters, it is therefore necessary to either configure HyperTerminal to enable Local Echo, to issue the `uecho on` console command, or to rebuild the project with the `ZAURA_RF_UartEcho` configuration variable set to `TRUE` in the `..\Conf\ZAURA_RF_Conf.c` configuration file.
4. Apply power. A user prompt should appear on the terminal. If the prompt does not appear, press the Enter key a few times in HyperTerminal. If the prompt still does not appear, slide SW3 to the opposite position and then back to its original position.

---

► **Note:** When the USB cable is disconnected and reconnected from the ZAURA RF Wireless Module, it is necessary to restart HyperTerminal so it recognizes that the virtual COM port is present.

---

Refer to the ZAURA RF Wireless Module Shell User Manual (UM0235) for command details.

## Demonstration Project

The ZAURA RF Wireless Module demonstration project shows how to develop wireless applications using the ZAURA RF and Shell libraries. These libraries contain the components indicated in Table 3.

**Table 3. ZAURA RF Wireless Module Library Components**

Library	Use
ZAURA_RF_866p5_MHz.lib	An RF library for the 863 to 870MHz ISM band.
ZAURA_RF_915_MHz.lib	An RF library for the 902 to 928MHz ISM band.
ZAURA_RF_Shell.lib	A command line interpreter and sample commands for use with either of the above libraries. It is an interactive console used primarily to develop new applications.
No_Shell.lib	A stub library to use in place of the Shell library for embedded applications.

### Set Up the Hardware

1. Connect the development board to a PC using a USB Mini-B to Type A cable.
2. Launch HyperTerminal on the PC.
3. Configure HyperTerminal for 57,600 bits per second, 8 data bits, no parity, 1 stop bit and, optionally, with hardware flow control enabled. By default, the ZAURA RF Shell Library does not echo typed characters back to the console. To see typed characters, it is therefore necessary to either configure HyperTerminal to enable Local Echo, to issue the `uecho` on console command, or to rebuild the project with the `ZAURA_RF_UartEcho` configuration variable set to `TRUE` in the `..\Conf\ZAURA_RF_Conf.c` configuration file.
4. Ensure the following settings:
  - a. SW3 is set to either USB PWR ON if not using batteries, or BAT PWR ON if two AA batteries have been installed.
  - b. Jumpers J3 and J5 are in place.

### Build the Project

1. The ZAURA RF Wireless Library is contained in a zip file labeled PUG0030-SC01.zip; this file is downloadable free from the Zilog website. Extract the contents of this zip file to an appropriate location on your hard drive.
2. Launch ZDSII, navigate to `..\ZAURA_RF_Wireless_vX.XXy\Demo` and open the `ZAURA_RF_Demo.zdsproj` project file, which is located inside the Demo folder.

---

► **Note:** vX.XXy refers to the version of the ZAURA RF software that was downloaded in Step 1.

---

3. In the **Build Configuration** window, select either the **866p5\_MHz** build option or the **915\_MHz** build option based on the frequency band of the Module you are using.
  4. Next, select the **Build** → **Rebuild All** menu option.
  5. Download the project using the **Tools** → **Flash Loader** option or the **Debug** → **Go** menu option.
- 

► **Note:** Some functions of the Demo project will place the Z8F2480 MCU into Stop Mode, which will terminate the debug session.

---

## Run the Demo without a Terminal

When power is initially applied to the ZAURA RF Wireless Module and its development board, LED D1 and LED D2 will each illuminate. After initialization completes, LED D1 is extinguished and LED D2 remains illuminated.

Red LED D2 illuminates to indicate that the ZAURA\_RF\_Demo firmware is running and the radio is in Receive Mode. When SW1 is pressed, the state of LED D1 on the (local) ZAURA RF Wireless Development Board is toggled and a broadcast message is transmitted to other ZAURA RF Wireless modules. Modules within radio range of the transmitter that receive the broadcast will configure LED D1 on their development boards to match the state of LED D1 on the transmitter. Nodes that do not receive the broadcast will not change the state of LED D1 on their development boards. For example, if LED D1 is initially OFF and SW1 is pressed, LED D1 is illuminated on that node and a broadcast message is transmitted, directing other ZAURA RF modules to illuminate LED D1 on their development boards. Any modules that do not receive the broadcast will not alter the state of LED D1 on their development boards.

If SW2 is pressed, both red LEDs D1 and D2 turn OFF, indicating that the ZAURA RF Wireless Module is in a low power state and is unable to communicate with other nodes. If SW1 is pressed while the Module is in the low power state, the unit is returned to Active Mode, LED D2 illuminates, and the radio is placed into Receive Mode.

## Run the Demo with a Terminal

When the ZAURA RF Wireless Module is used with a USB Mini-B to Type A cable connected to a PC running HyperTerminal, the operator can use the interactive console to send and receive arbitrary packets in response to commands entered on the console.

For example, in the console display that follows, the operator sends the message, "Hello world" to a specific Module, changes the Module's station address and manipulates a GPIO port pin on the remote station.

```
ZAURA RF Wireless v1.10a Build 11081801
```

```
-----  
FW checksum 7C57
```

```
>tx 56 "Hello world"  
Transmit DA 56 Data: Hello world
```

```
Done transmit
```

```
>remote addr  
local address: 56
```

```
>remote addr F7
```

```
>remote port e ^ 20  
Port_E initially 20 now 00
```

For more information about developing an application using the ZAURA RF Wireless Module libraries, please refer to the [ZAURA RF Wireless Module Reference Manual \(RM0060\)](#), available on [www.zilog.com](http://www.zilog.com).



## Appendix A. Schematic Diagrams

Figures 6 and 7 display schematic representations of the ZAURA RF Wireless Development Board.

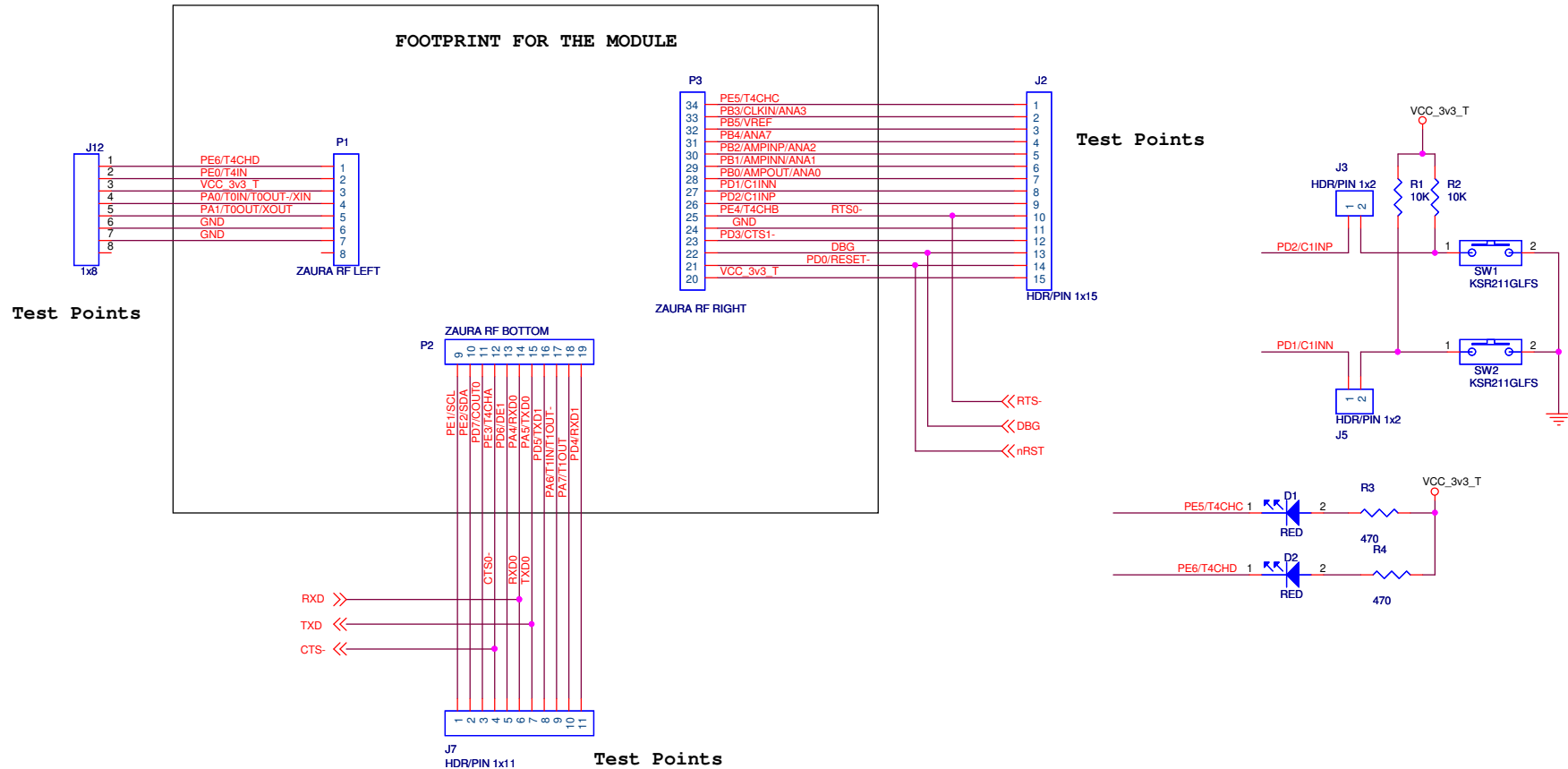

Figure 6. ZAURA RF Wireless Development Board, #1 of 2

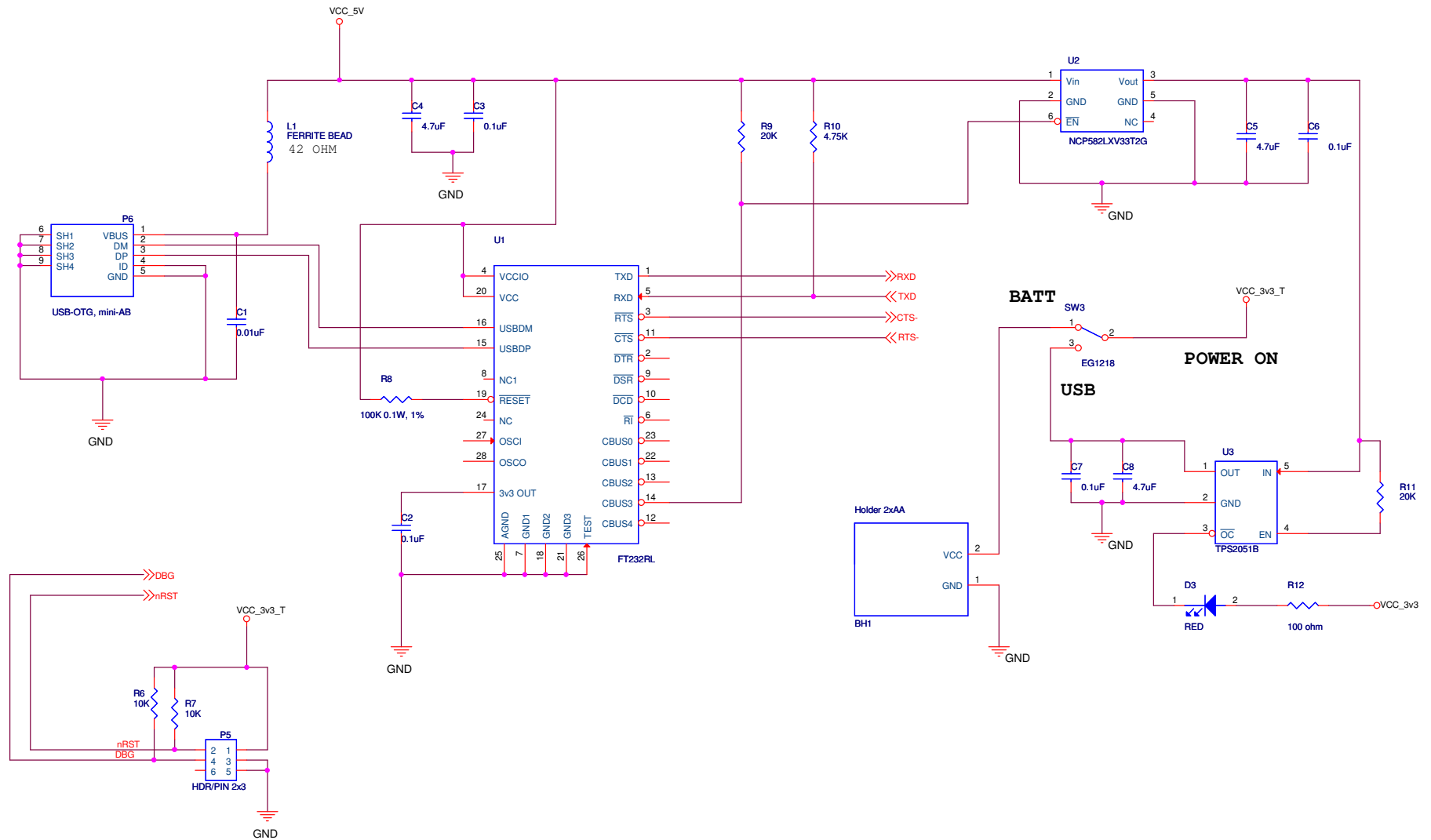

Figure 7. ZAURA RF Wireless Development Board, #2 of 2

Figures 8 and 9 display schematics of the ZAURA RF Wireless 868MHz Module.

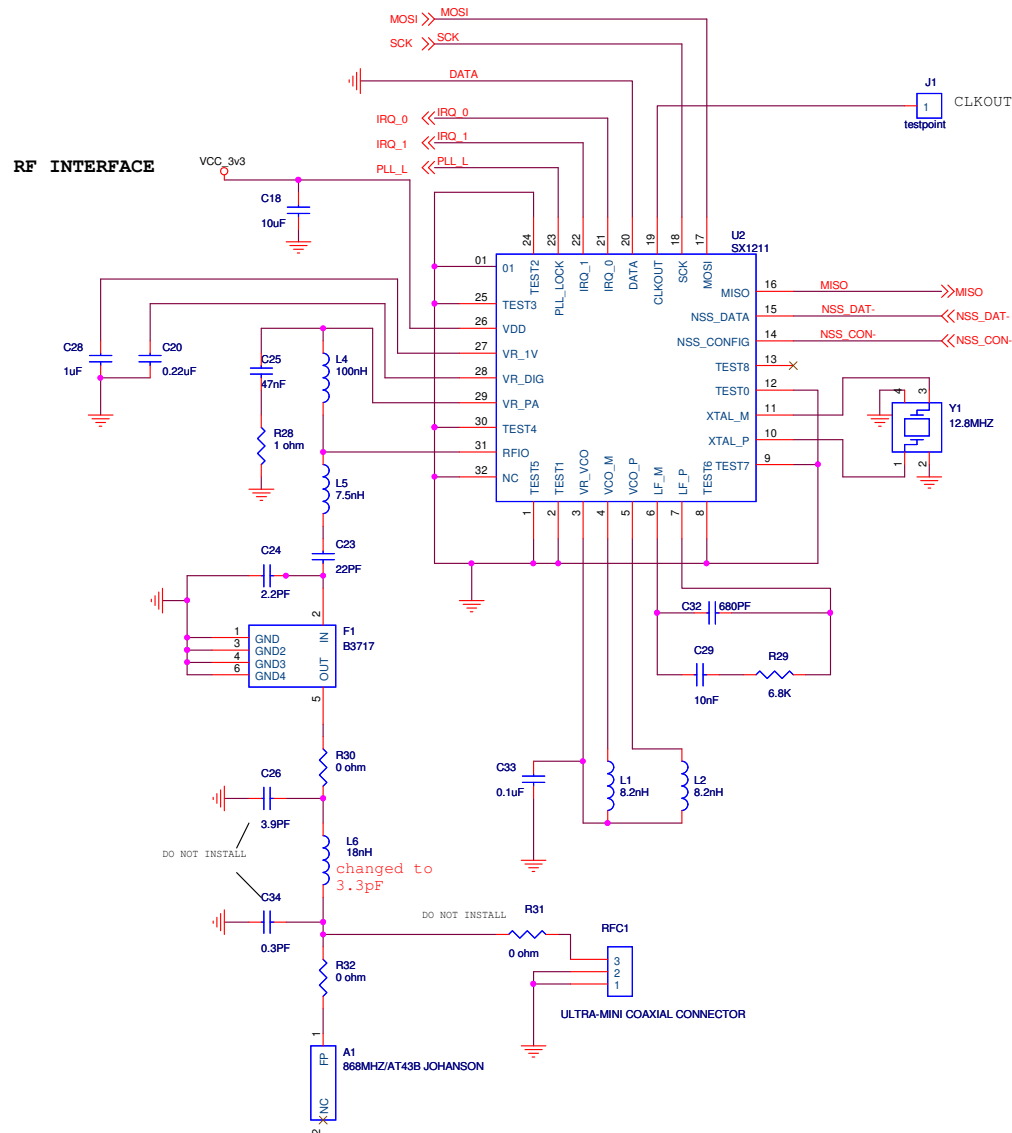

Figure 8. ZAURA RF Wireless 868MHz Module, #1 of 2

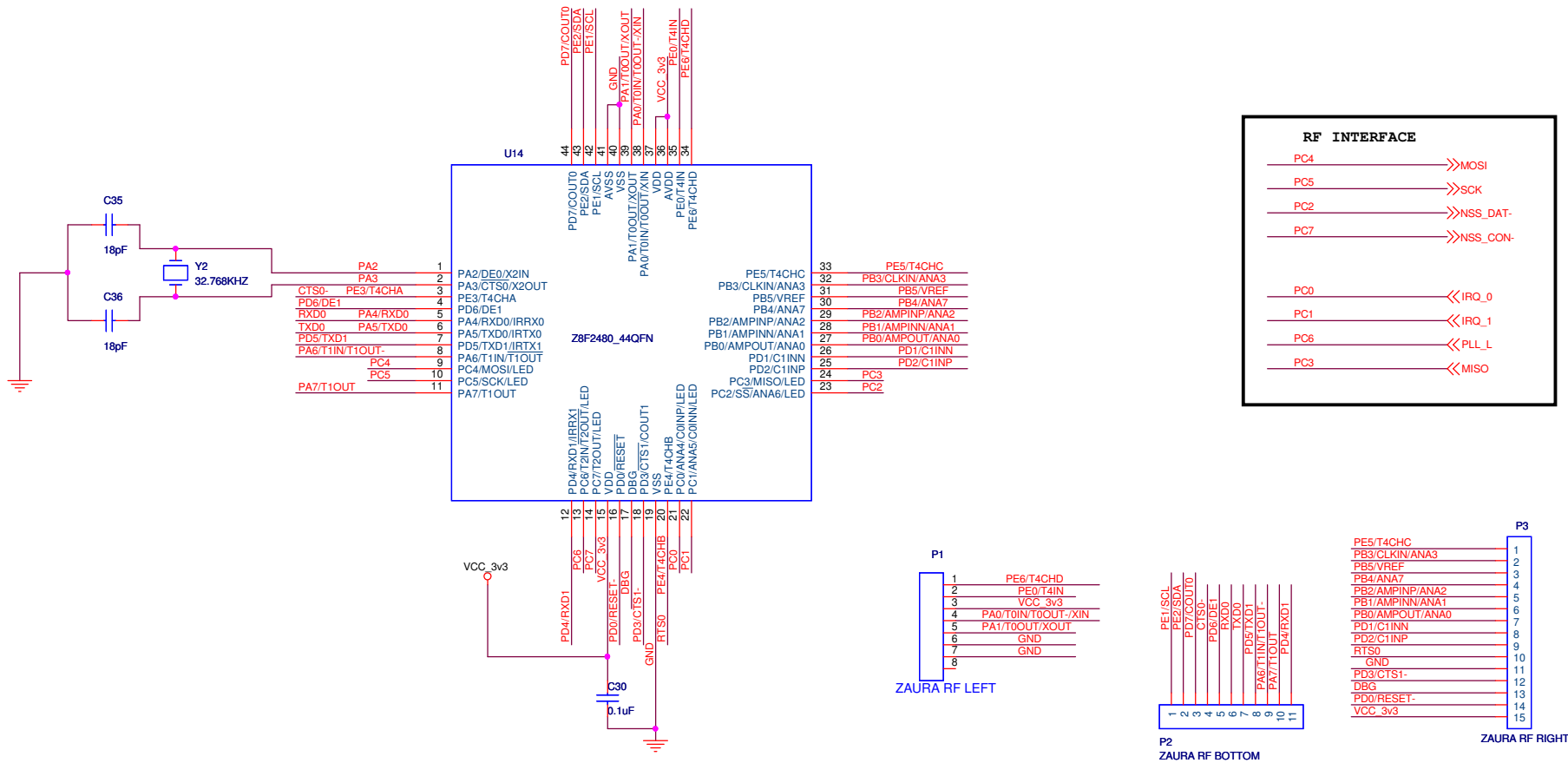

Figure 9. ZAURA RF Wireless 868MHz Module, #2 of 2



Figures 10 and 11 display schematics of the ZAURA RF Wireless 915MHz Module.

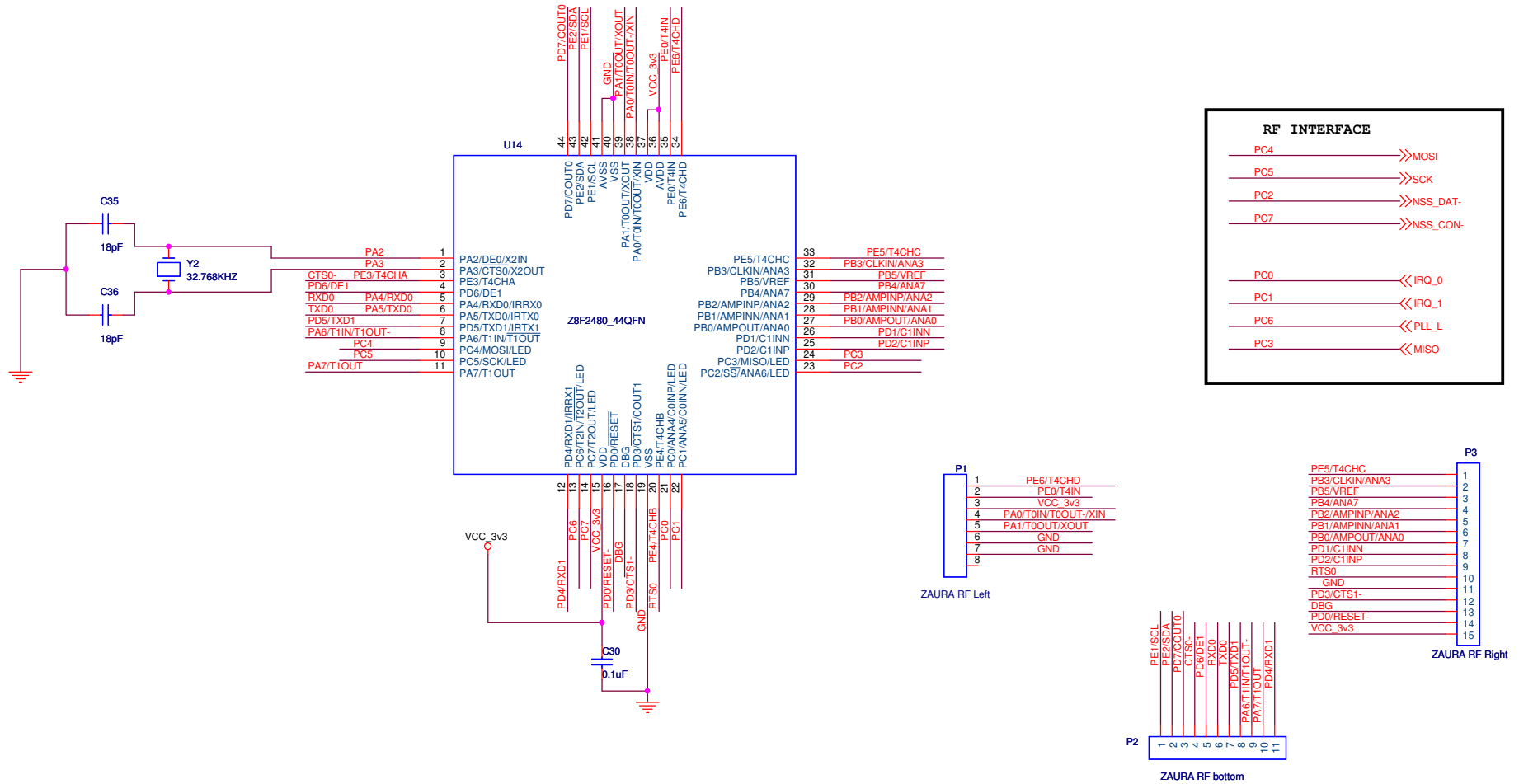

Figure 10. ZAURA RF Wireless 915MHz Module, #1 of 2

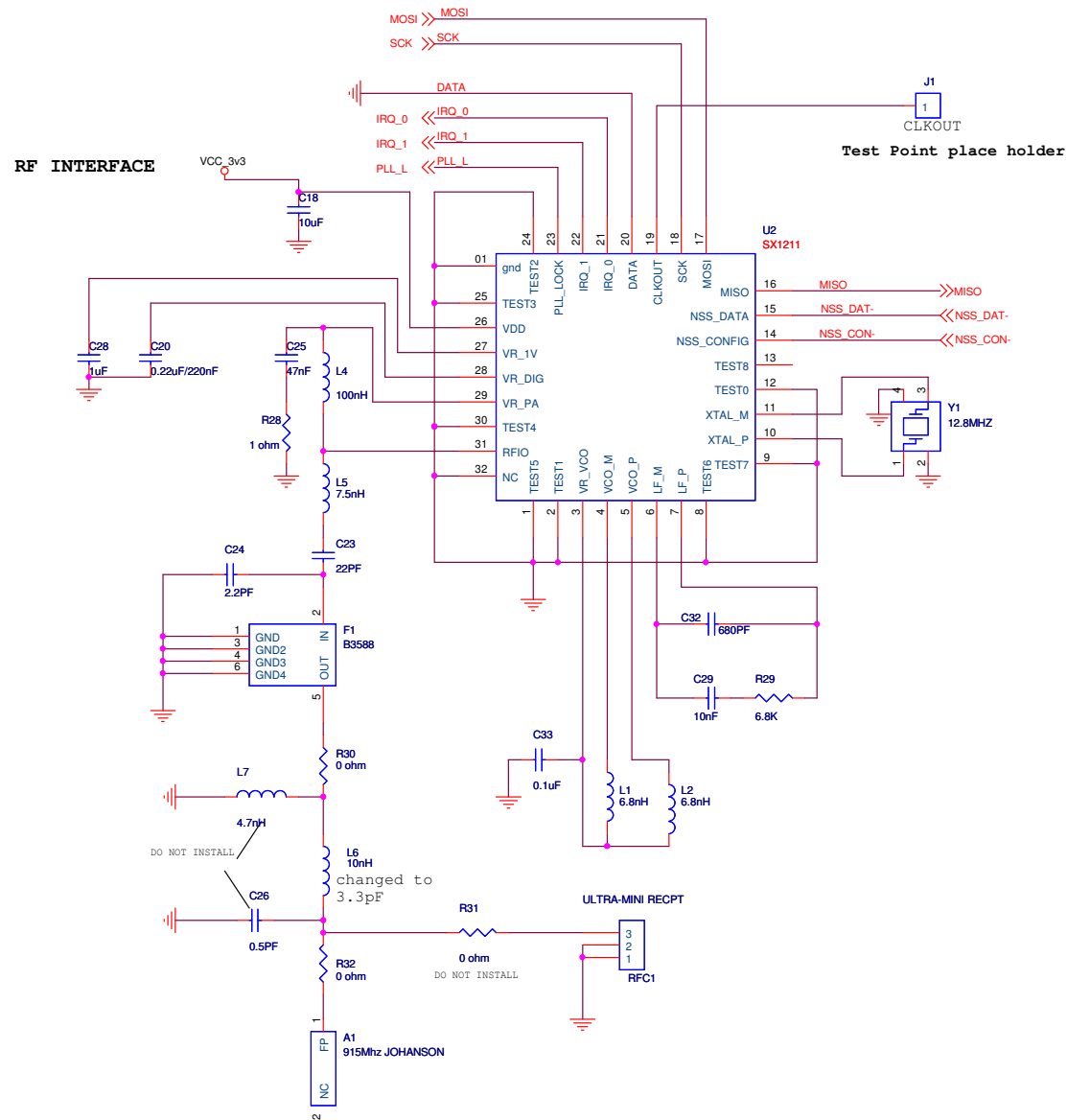

Figure 11. ZAURA RF Wireless 915MHz Module, #2 of 2

## Precharacterization Product

The product represented by this document is newly introduced and Zilog has not completed the full characterization of the product. The document states what Zilog knows about this product at this time, but additional features or nonconformance with some aspects of the document might be found, either by Zilog or its customers in the course of further application and characterization work. In addition, Zilog cautions that delivery might be uncertain at times, due to start-up yield issues.

## Ordering Information

The ZAURA RF Wireless 868MHz and 915MHz Modules are each available as development kits, as listed in Table 4. Each kit includes two ZAURA RF Wireless Modules and two ZAURA RF Wireless development boards. Both ZAURA RF Wireless Module Development Kits can be ordered from the [Zilog website](#) using the part numbers listed in Table 4. For more information about ordering, please consult your local [Zilog Sales Office](#). The Zilog website ([www.zilog.com](http://www.zilog.com)) lists all regional offices and provides additional information about ZAURA RF Wireless Technology products.

**Table 4. ZAURA RF Wireless Module Ordering Information**

Part Number	Description
ZAURA868100MODG	ZAURA RF Wireless 868MHz Module
ZAURA915100MODG	ZAURA RF Wireless 915MHz Module
ZAURA868100KITG	ZAURA RF Wireless 868MHz Module Development Kit
ZAURA915100KITG	ZAURA RF Wireless 915MHz Module Development Kit

## Related Documentation

The documents associated with the ZAURA RF Wireless Modules are listed in Table 5 and can also be found on the Zilog website at [www.zilog.com](http://www.zilog.com).

**Table 5. ZAURA RF Wireless Module Documentation**

Document Number	Description
PUG0030	This ZAURA RF Wireless Module Reference Design document
PUG0030-SC01	ZAURA RF Wireless Library
UM0235	ZAURA RF Module Shell User Manual
RM0060	ZAURA RF Wireless Library Reference Manual

---

## Customer Support

To learn more about this product, find additional documentation, get your technical questions answered or report issues, please contact [esales@zillog.com](mailto:esales@zillog.com).



**Warning:** DO NOT USE THIS PRODUCT IN LIFE SUPPORT SYSTEMS.

---

### LIFE SUPPORT POLICY

ZILOG'S PRODUCTS ARE NOT AUTHORIZED FOR USE AS CRITICAL COMPONENTS IN LIFE SUPPORT DEVICES OR SYSTEMS WITHOUT THE EXPRESS PRIOR WRITTEN APPROVAL OF THE PRESIDENT AND GENERAL COUNSEL OF ZILOG CORPORATION.

### As used herein

Life support devices or systems are devices which (a) are intended for surgical implant into the body, or (b) support or sustain life and whose failure to perform when properly used in accordance with instructions for use provided in the labeling can be reasonably expected to result in a significant injury to the user. A critical component is any component in a life support device or system whose failure to perform can be reasonably expected to cause the failure of the life support device or system or to affect its safety or effectiveness.

### Document Disclaimer

©2011 Zilog, Inc. All rights reserved. Information in this publication concerning the devices, applications, or technology described is intended to suggest possible uses and may be superseded. ZILOG, INC. DOES NOT ASSUME LIABILITY FOR OR PROVIDE A REPRESENTATION OF ACCURACY OF THE INFORMATION, DEVICES, OR TECHNOLOGY DESCRIBED IN THIS DOCUMENT. ZILOG ALSO DOES NOT ASSUME LIABILITY FOR INTELLECTUAL PROPERTY INFRINGEMENT RELATED IN ANY MANNER TO USE OF INFORMATION, DEVICES, OR TECHNOLOGY DESCRIBED HEREIN OR OTHERWISE. The information contained within this document has been verified according to the general principles of electrical and mechanical engineering.

ZAURA and Z8 Encore! XP are trademarks or registered trademarks of Zilog, Inc. All other product or service names are the property of their respective owners.