



Chipsmall Limited consists of a professional team with an average of over 10 year of expertise in the distribution of electronic components. Based in Hongkong, we have already established firm and mutual-benefit business relationships with customers from,Europe,America and south Asia,supplying obsolete and hard-to-find components to meet their specific needs.

With the principle of “Quality Parts,Customers Priority,Honest Operation,and Considerate Service”,our business mainly focus on the distribution of electronic components. Line cards we deal with include Microchip,ALPS,ROHM,Xilinx,Pulse,ON,Everlight and Freescale. Main products comprise IC,Modules,Potentiometer,IC Socket,Relay,Connector.Our parts cover such applications as commercial,industrial, and automotives areas.

We are looking forward to setting up business relationship with you and hope to provide you with the best service and solution. Let us make a better world for our industry!



## Contact us

Tel: +86-755-8981 8866 Fax: +86-755-8427 6832

Email & Skype: info@chipsmall.com Web: www.chipsmall.com

Address: A1208, Overseas Decoration Building, #122 Zhenhua RD., Futian, Shenzhen, China





## Dual Rocker Self-Powered ZigBee® Switch

ZBT-S2AWH (dual rocker, white)

### Overview

The Dual Rocker Self-Powered ZigBee Switch is a wireless transmitter that communicates with a wide variety of ZigBee compatible systems. The switch uses battery-free, energy harvesting technology. Every time the switch is pressed a micro-generator produces a small electrical current that powers a built-in transmitter. This transmitter sends wireless radio signals that are used to remotely control a compatible system.

### Compatible With

ZigBee Green Power  
(included in ZigBee 3.0)

### Specifications

ZBT-S1AWH	Single Rocker Self-Powered ZigBee Switch
Range	30-100 ft or 10-30 m (typical)
Frequency	2.4 GHz (ZigBee channels 11-26)
Power Supply	Self-generated when switch is pressed
Buttons	4 (2 rockers)
Dimensions	2.75 (W) x 4.5 (H) x 0.62 (D) inches
Operating Temperature	-13° to +149° F (-25° to +65° C)
Radio Certifications	Certified according to FCC, IC and CE regulations
Addressing	Factory Set Unique ID

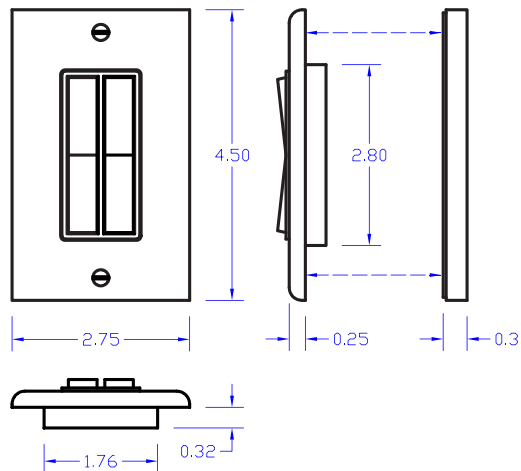

Contains FCC ID: SVZ-PTM215Z

Contains IC: 5713A-PTM215Z

The enclosed device complies with Part 15 of the FCC Rules. Operation is subject to the following two conditions: (i.) this device may not cause harmful interference and (ii.) this device must accept any interference received, including interference that may cause undesired operation.

Always follow local electrical codes when installing this device. Installation should be performed by a qualified electrician.

This device or certain aspects thereof is protected by at least one of the U.S. or international patent or has at least one such patent application pending.

### Mounting

**Commission (link) the switch to the compatible system before mounting.**

The light switch is compatible with standard decorator style faceplates.

A faceplate is included.

#### Surface Mount

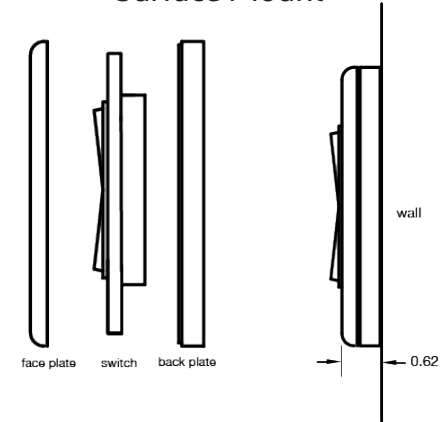

For surface mount, attach included backplate to the wall using screws or adhesive.

#### Flush Mount

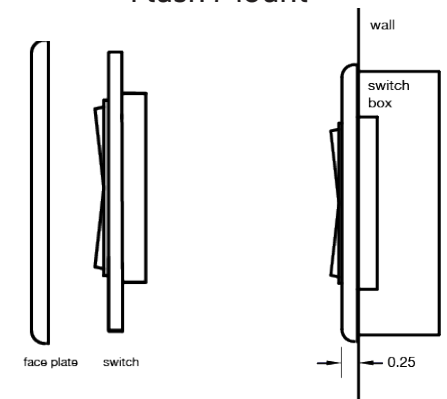

For flush mount, mount the switch without the backplate into either a standard electrical switch box or a low voltage mounting bracket using included screws.

# Commissioning

## Part 1

### Activate commissioning (or linking) mode for a system compatible with the switch.

If you don't know how to do this, consult the manual for the compatible system or contact the manufacturer for assistance.

## Part 2

### Put the switch into commissioning mode.

To enter commissioning mode, start by selecting one button on the switch. (Use the same button for the entire sequence. Pressing any other button will exit the commissioning mode.)

### Next, execute the following long-short-long sequence:

1. Press and hold the selected button for more than 7 seconds before releasing it
2. Press the selected button quickly (hold for less than 2 seconds)
3. Press and hold the selected button again for more than 7 seconds before releasing it

### The switch has now entered commissioning mode.

## Part 3

### Linking the switch to the compatible system.

A radio signal needs to be sent from the switch to the compatible system on the correct ZigBee channel. The system uses one of sixteen possible channels, automatically set by the system. Using the switch, a signal will be sent on each channel until the channel used by the compatible system is found.

Upon entering commissioning mode, the switch sends a signal on the currently selected channel. The signal is sent on the default channel 11, unless the switch had been put on another channel previously. (This allows linking additional devices without changing the currently used radio channel.)

### Here is a chart of the ZigBee channels and the corresponding radio frequencies (in MHz).

Channel ID	Lower Frequency	Center Frequency	Upper Frequency
11	2404	2405	2406
12	2409	2410	2411
13	2414	2415	2516
14	2419	2420	2421
15	2424	2425	2426
16	2429	2430	2431
17	2434	2435	2436
18	2439	2440	2441
19	2444	2445	2446
20	2449	2450	2451
21	2454	2455	2456
22	2459	2460	2461
23	2464	2465	2466
24	2469	2479	2471
25	2474	2475	2476
26	2479	2480	2481

AHD0612B

## Cycle through the sixteen channels

To change the switch's channel, short press the selected switch button (less than 7 seconds) once after entering commissioning mode. This will reset the channel used by the switch to channel 11.

*If the switch was already operating on channel 11 (default condition) then the radio channel will remain unchanged. This ensures that the switch will always use channel 11 as the starting point for the channel adjustment.*

Short press the selected button (less than 7 seconds) again to move to the next channel. For each such button press, the switch transmits on the next channel. If channel 26 has been reached then channel 11 will be used next.

When the switch is on the correct channel, the compatible system will provide a link confirmation indication. Consult the instructions for the compatible system for details of the link confirmation indication. There should be a visible or audible exchange indicated on the system, and the switch will be linked to the system.

Exit linking mode on the switch by pressing any other button on the switch.

Once the linking process is complete, work with the compatible system to define the behavior of individual buttons on the switch. For problems with the compatible system, please contact to the system provider.